

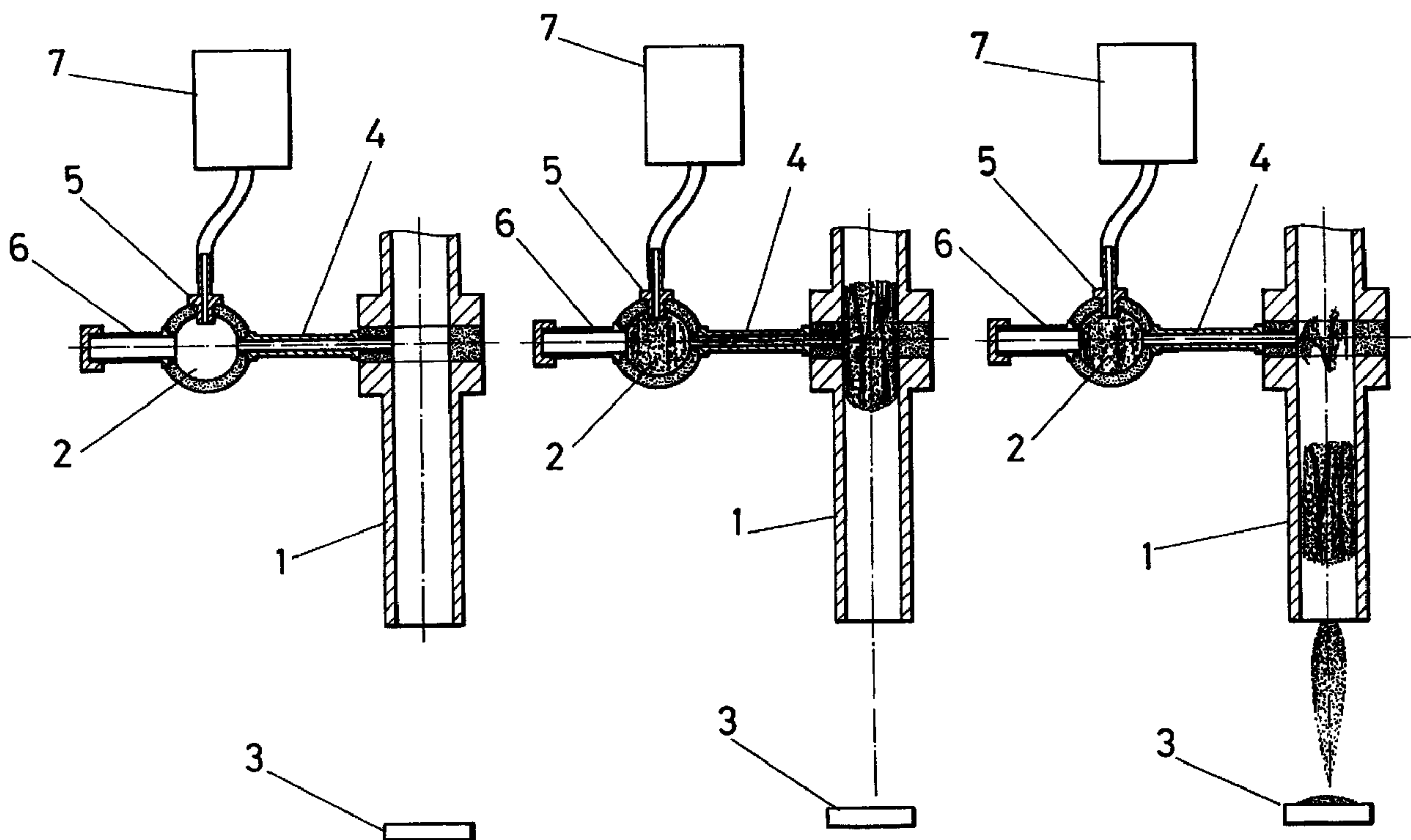

(86) Date de dépôt PCT/PCT Filing Date: 1998/01/23
 (87) Date publication PCT/PCT Publication Date: 1999/07/29
 (45) Date de délivrance/Issue Date: 2008/11/04
 (85) Entrée phase nationale/National Entry: 2000/07/24
 (86) N° demande PCT/PCT Application No.: ES 1998/000015
 (87) N° publication PCT/PCT Publication No.: 1999/037406

(51) Cl.Int./Int.Cl. *B05B 7/20* (2006.01)
 (72) Inventeurs/Inventors:
 DE JUAN LANDABURU, JULIAN, ES;
 FAGOAGA ALTUNA, IGNACIO, ES;
 BARYKIN, GEORGIY, ES
 (73) Propriétaire/Owner:
 AEROSTAR COATINGS, S.L., ES
 (74) Agent: FETHERSTONHAUGH & CO.

(54) Titre : SYSTEME D'INJECTION DE POUDRE POUR PISTOLET DE PROJECTION PAR DETONATION
 (54) Title: POWDER INJECTION SYSTEM FOR A DETONATION SPRAY GUN



(57) Abrégé/Abstract:

The powder injection system is comprised of a dosing chamber (2) which is directly supplied by a conventional powder supplier (7) and communicates with the barrel (1) of the detonation gun through a direct conduit (5). Thus, the pressure wave which progresses through the barrel (1) enters through the communication conduits (5) and, when reaching the dosing chamber (2), is subjected to a sudden expansion which stops the powder supply from the continuous supplier (7) and produces the complete fluidification of the powder contained in the dosing chamber (2). The fluidized powder will then be entrained by suction up to the barrel (1) where it resides until the pressure wave generated in a new detonation cycle entrains said powder to deposit it to the surface of the part to be coated.



PCT ORGANIZACION MUNDIAL DE LA PROPIEDAD INTELECTUAL
Oficina Internacional
SOLICITUD INTERNACIONAL PUBLICADA EN VIRTUD DEL TRATADO DE COOPERACION
EN MATERIA DE PATENTES (PCT)

<p>(51) Clasificación Internacional de Patentes ⁶ : B05B 7/20</p>	A1	<p>(11) Número de publicación internacional: WO 99/37406</p> <p>(43) Fecha de publicación internacional: 29 de Julio de 1999 (29.07.99)</p>
<p>(21) Solicitud internacional: PCT/ES98/00015</p> <p>(22) Fecha de la presentación internacional: 23 de Enero de 1998 (23.01.98)</p> <p>(71) Solicitante (para todos los Estados designados salvo US): AEROSTAR COATINGS, S.L. [ES/ES]; Gabiria, 82-84, Poligono Industrial de Ventas, E-20305 Irun (ES).</p> <p>(72) Inventores; e</p> <p>(75) Inventores/solicitantes (sólo US): DE JUAN LANDABURU, Julian [ES/ES]; Satarka 4, 3º D, E-20280 Hondarribia (ES). FAGOAGA ALTUNA, Ignacio [ES/ES]; General Leiva 7, 4º D, E-20280 Hondarribia (ES). BARYKIN, Georgiy [UA/ES]; Carquizano 4, 2º A, E-20013 San Sebastian (ES).</p> <p>(74) Mandatario: CARPINTERO LOPEZ, Francisco; Herrero & Asociados, S.L., Alcalá, 21, E-28014 Madrid (ES).</p>	<p>(81) Estados designados: AL, AM, AT, AU, AZ, BA, BB, BG, BR, BY, CA, CH, CN, CU, CZ, DE, DK, EE, ES, FI, GB, GE, GH, HU, IL, IS, JP, KE, KG, KP, KR, KZ, LC, LK, LR, LS, LT, LU, LV, MD, MG, MK, MN, MW, MX, NO, NZ, PL, PT, RO, RU, SD, SE, SG, SI, SK, SL, TJ, TM, TR, TT, UA, UG, US, UZ, VN, YU, ZW, Patente ARIPO (GH, GM, KE, LS, MW, SD, SZ, UG, ZW), Patente euroasiática (AM, AZ, BY, KG, KZ, MD, RU, TJ, TM), Patente europea (AT, BE, CH, DE, DK, ES, FI, FR, GB, GR, IE, IT, LU, MC, NL, PT, SE), Patente OAPI (BF, BJ, CF, CG, CI, CM, GA, GN, ML, MR, NE, SN, TD, TG).</p> <p>Publicada <i>Con informe de búsqueda internacional.</i></p>	

(54) Title: POWDER INJECTION SYSTEM FOR DETONATION-OPERATED PROJECTION GUN

(54) Título: SISTEMA DE INYECCION DE POLVO PARA UNA PISTOLA DE PROYECCION POR DETONACION

(57) Abstract

The powder injection system is comprised of a dosing chamber (2) which is directly supplied by a conventional powder supplier (7) and communicates with the barrel (1) of the detonation gun through a direct conduit (5). Thus, the pressure wave which progresses through the barrel (1) enters through the communication conduits (5) and, when reaching the dosing chamber (2), is subjected to a sudden expansion which stops the powder supply from the continuous supplier (7) and produces the complete fluidification of the powder contained in the dosing chamber (2). The fluidized powder will then be entrained by suction up to the barrel (1) where it resides until the pressure wave generated in a new detonation cycle entrains said powder to deposit it to the surface of the part to be coated.

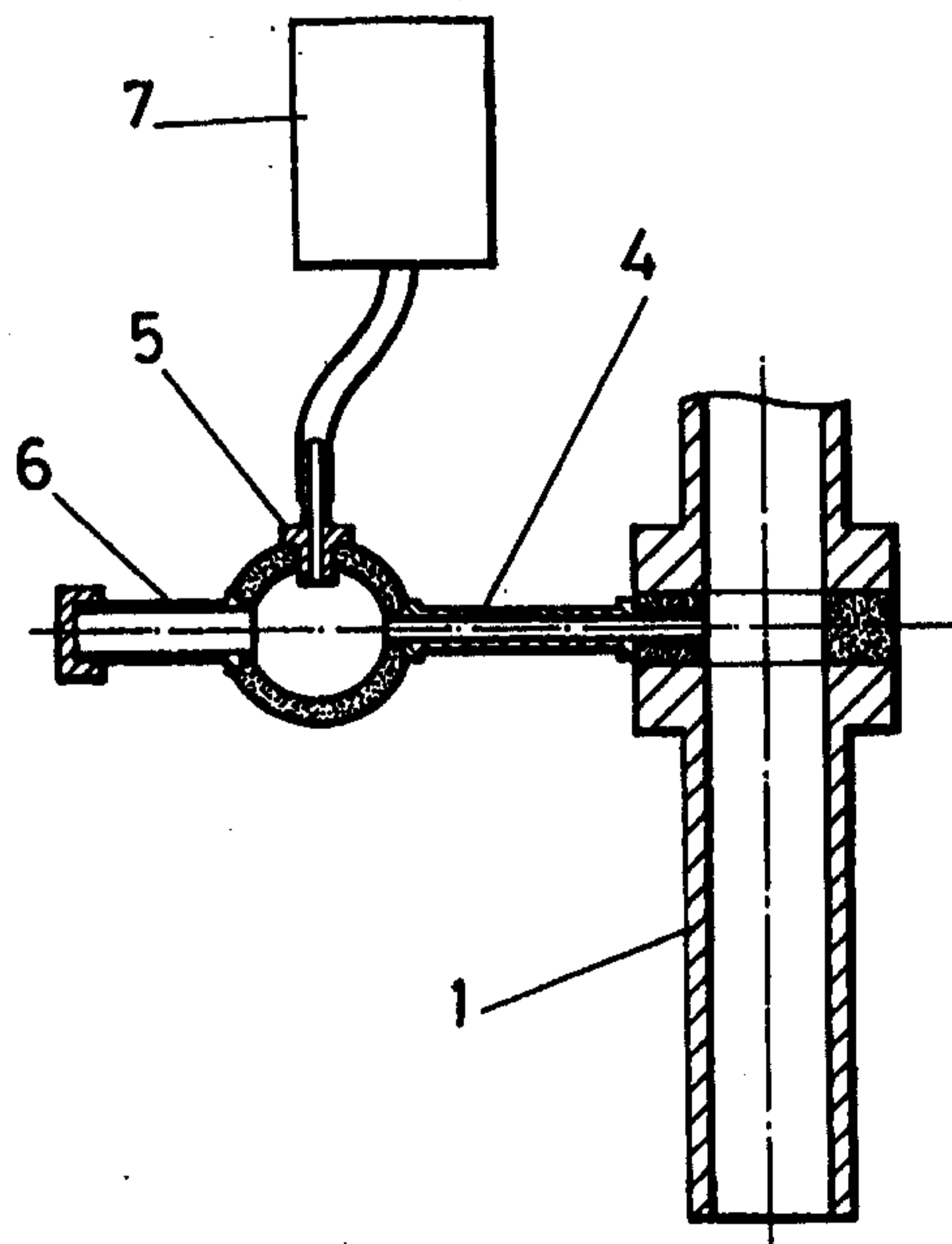

(57) Resumen

El sistema de inyección de polvo está compuesto por una cámara de dosificación (2) alimentada directamente por un alimentador de polvo convencional (7) y comunicada con el cañón (1) de la pistola de detonación a través de un conducto directo (5). De esta forma, la onda de presión que avanza a través del cañón (1) entra por el conducto de comunicación (5) y al alcanzar la cámara de dosificación (2), sufre una expansión brusca que interrumpe la alimentación de polvo desde el alimentador continuo (7) y produce la fluidificación completa del polvo contenido en la cámara de dosificación (2). El polvo fluidificado será arrastrado por succión hasta el cañón (1) donde permanece hasta que la onda de presión generada en un nuevo ciclo de detonación lo arrastre depositándolo sobre la superficie de la pieza a revestir.

POWDER INJECTION SYSTEM FOR A DETONATION SPRAY GUND E S C R I P T I O N

5 OBJECT OF THE INVENTION

This invention relates to the field of thermal spray technologies for applying coatings, and in particular to detonation thermal spray.

10

The object of the present invention is a powder injection apparatus which, when incorporated to a detonation system allows increasing its precision, reliability, versatility and productivity.

15

BACKGROUND OF THE INVENTION

At this time, detonation spray technology is mainly used to apply coatings to workpieces exposed to severe wear, heat or corrosion and is fundamentally based on using the kinetic energy produced in the detonation of a combustible mixture of gases to deposit powdered coating materials on workpieces.

25

Coating materials typically used in detonation processes include powder forms of metals, metal-ceramics and ceramics and are applied to improve resistance to wear, erosion, corrosion, as thermal insulators and as electrical insulators or conductors.

30

Spraying by detonation is performed by spray guns which basically consist of a tubular detonation chamber, with one end closed and another open, to the latter being attached an also tubular barrel. A combustion mixture is injected into the detonation chamber and ignition of the gas mixture is achieved with a spark plug, causing a detonation and consequently a shock or pressure wave which travels at supersonic speeds inside the chamber and then inside the barrel until it leaves through the open end of the barrel.

The coating material powder is generally injected into the barrel in front of the propagating shock wave front and is then carried out to the open end of the barrel and deposited onto a substrate or workpiece placed in front of the barrel. The impact of the coating powder onto the substrate produces a high-density coating with good adhesive characteristics.

This process is repeated cyclically until the part is adequately covered.

Powder feeders commercially available supply a continuous feeding which makes them adequate for high-velocity or plasma spray technologies, since detonation is a discontinuous process which therefore requires a discontinuous powder feeding.

On the other hand, feeders used in detonation devices provide discontinuous feeding by using devices which

control the amount of powder supplied to the detonation barrel in each explosion, but they are always devices designed specifically for each type of gun, that is, they cannot be interchanged for use with other guns or
5 in other machines which require feeding powder. With respect to the powder measuring system employed, they can be classified in two categories:

10 a) Mechanical: These devices use moving mechanisms (valves, spindles, gears, etc.) to introduce constant quantities of powder in each detonation cycle. Devices of this type are described for example in U.S. Patents 3.109.680 and in European Patent 0 484 533.

15 These devices have the main advantage of providing precise measurements but are however of great complexity (they have many components), their reliability is low since they require periodic
20 maintenance to maintain the precision of the measurement and their productivity is low since they are limited to low operation frequencies.

25 b) Pneumatic: These devices use gas pulses synchronised with the detonation pulses to introduce the powder cyclically in the detonation barrel, these pulses sometimes being obtained from the detonation process itself. The elegance and mechanical simplicity of these devices has
30 contributed to their wide use despite their

precision being questioned. There are also numerous Patent documents such as PCT US Patent 9620129 by the same authors.

5 These devices share the characteristic of incorporating a volume or deposit in which a limited amount of powder is stored, which by gravity feeds another volume or dosage chamber which feeds the detonation barrel by a gas impulse.
10 The disadvantage of these systems is their lack of precision in the amount of powder dosed, mainly due to their difficulty, over long spray periods, of keeping stable the volume and/or pressure of the feeding deposit. This is due to the fact that part
15 of the detonation wave enters the powder feeding deposit, pressurizing it so that the powder falls under gravity and due to the pressure existing in the deposit at each time.

20 In addition, since the amount of powder entering the dosage chamber cannot be perfectly controlled, the degree of fluidization produced by the impulse gas cannot be controlled either, and thus it is difficult to know precisely the amount of powder
25 injected into the barrel.

 Furthermore, since in these devices feeding from the deposit to the dosing chamber is by gravity, when the detonation gun, generally handled by an
30 industrial robot, assumes positions in which the

powder deposit is not vertical, the powder will not fall into the dosage chamber continuously, and thus it is difficult to ensure a constant feeding.

5 Document GB-A-2 192 815 is known in prior art, which describes a detonation coating device comprising a barrel open at one end, a gas feeding system, a blast initiating assembly and a powder bath metering unit consisting of a vertically
10 oriented bunker changing at its lower part into a vertical tube under which, inside the barrel, a horizontal rack is located. The barrel is oriented vertically with its axis parallel to the axis of the bunker, whereas the tube is connected to the
15 barrel through the closed butt-end of the latter.

This detonation coating device is not suitable for providing good coatings with any kind of materials, but it is only appropriate for particular coatings.

20

DESCRIPTION OF THE INVENTION

The present invention fully solves the above disadvantages by using an injection system which allows
25 employing a conventional type continuous powder feeder for feeding a detonation spray system, the powder injection being performed cyclically, in synchronization with the gun spray frequency and with great precision in the powder dosage.

30

The system proposed allows directly connecting the gun and the continuous powder feeder and consists of a dosage chamber which receives the continuous powder feeding and a conduit which directly communicates the chamber with the gun barrel, so that in each detonation cycle the detonation pressure wave reaches the dosage chamber, momentarily interrupting the feeding so that the ensuing suction of the detonation wave carries the powder contained in the dosage chamber injecting it into the gun barrel.

With this object the dosage chamber communicates with the gun barrel by a direct tubular conduit of small diameter, so that the pressure wave that advances through the barrel passes to the communication conduit and on reaching the dosage chamber undergoes a sudden expansion which fills the chamber with pressurized gas, blocking the entry of the powder feeding conduit. In this way, the feeding of powder from the continuous feeder is cyclically interrupted, and it is therefore possible to determine the exact amount of powder present in the dosage chamber at the time of detonation.

The sudden expansion of the gas in the dosage chamber creates a turbulence which produces the fluidization of all the powder contained in the dosage chamber so that the suction process, which follows the detonation, carries all the powder contained in the chamber, so that it is possible to control the exact amount of powder injected into the barrel. In addition, as the pressure

wave is composed of hot gases produced in the combustion process the interaction of these gases with the powder contained in the dosage chamber produces a preheating of the powder which favors its fluidization.

5

In this way, when the pressure wave generated in the detonation passes the communication conduit of the dosage chamber, the low pressure generated after the detonation wave creates a suction which carries the gas contained in the dosage chamber and the fluidized powder. The powder carried reaches the barrel, where it remains until the pressure wave generated in the following detonation cycle carries it, depositing it on the surface of the part to be coated.

15

With this injection system the pressure wave from the detonation is made to perform the injection of powder into the barrel cyclically and synchronized with the gun firing frequency, thus transforming a continuous powder feeding into a pulsed injection to the gun barrel without using complex mechanical devices.

20

In addition, the expansion created by the dosage chamber reduces the velocity of the pressure wave preventing it from eroding the dosage chamber and advancing into the powder feeder, eliminating the risk of it producing irreparable damages to the feeding system.

25

The dosage chamber presents an elongation or auxiliary chamber opposite the communication conduit to the

30

27395-91

- 8 -

detonation barrel which is meant to increase the length of the dosage chamber to reduce the force of the impact and therefore the effects of the erosion produced by the encounter of the gases and the powder in this area of the
5 dosage chamber.

The device of the invention presents the following advantages:

- It favors a cyclical interruption of the feeding by the detonation pressure wave.
 - 10 - It favors a preheating and fluidization of the powder by its interaction with the hot gases of the combustion.
 - It allows feeding a precise amount of powder in each explosion by the suction effect which follows the pressure wave in each detonation.
- 15 According to one aspect of the present invention, there is provided a powder injection system for a detonation spray gun of the type comprising a gas supply, an ignition source, and a barrel, the system comprising: an expansion and dosage chamber directly fed by a continuous powder feeding device;
20 and means for communicating with the expansion and dosage chamber and the barrel, the means being disposed so that a first pressure associated with gases traveling down the barrel, when reaching the expansion and dosage chamber, temporarily interrupts powder feeding until a subsequent
25 lower second pressure sucks powder contained in the expansion and dosage chamber to the barrel.

According to another aspect of the present invention, there is provided a powder injection system for a detonation spray gun of the type comprising a gas supply, an ignition source,
30 and a barrel, the system comprising: an expansion and dosage

27395-91

- 8a -

chamber directly fed by a continuous powder feeding device, wherein the expansion and dosage chamber incorporates an extension chamber, which increases the length of the expansion and dosage chamber; a communication conduit in
5 communication with the expansion and dosage chamber and the barrel, wherein the communication conduit is disposed so that a first pressure associated with gases traveling down the barrel, when reaching the expansion and dosage chamber temporarily interrupts powder feeding until a subsequent
10 lower second pressure sucks powder contained in the expansion and dosage chamber to the barrel.

According to still another aspect of the present invention, there is provided a method for introducing powder to a detonation spray gun of the type comprising a supply of
15 detonation gases, an ignition source, and a barrel having an open end, the method comprising: feeding the powder into an expansion and dosage chamber; feeding the detonation gases to the barrel; igniting the detonation gases to produce a detonation pulse; passing a portion of the detonation pulse
20 through a communication conduit to the expansion and dosage chamber; and interrupting the feeding of powder into the expansion and dosage chamber and drawing the powder from the expansion and dosage chamber into the barrel with said portion of the detonation pulse.

25 According to yet another aspect of the present invention, there is provided a method for introducing powder to a detonation spray gun of the type comprising a supply of detonation gases, an ignition source, and a barrel having an open end, the method comprising: feeding the powder into an
30 expansion and dosage chamber; feeding the detonation gases to the barrel; igniting the detonation gases to produce a detonation pulse; passing a portion of the detonation pulse through a communication conduit to the expansion and dosage

27395-91

- 8b -

chamber, wherein the communication conduit is in fluid communication with the expansion and dosage chamber and the barrel, wherein the portion of the detonation pulse in the expansion and dosage chamber interrupts the feeding of powder into the expansion and dosage chamber, and drawing the powder from the expansion and dosage chamber into the barrel, wherein the feeding is solely controlled by the detonation pulse.

According to a further aspect of the present invention, there is provided a powder injection system for a detonation spray gun of the type comprising a gas supply, an ignition source, and a barrel, the system comprising: an expansion and dosage chamber directly fed by a continuous powder feeding device, wherein the expansion and dosage chamber incorporates an auxiliary chamber, which increases the length of the expansion and dosage chamber; a communication conduit in communication with the expansion and dosage chamber and the barrel, wherein the communication conduit is disposed so that a first pressure associated with gases traveling down the barrel, when reaching the expansion and dosage chamber temporarily interrupts powder feeding until a subsequent lower second pressure sucks powder contained in the expansion and dosage chamber to the barrel.

DESCRIPTION OF THE DRAWINGS

To complement the description being made and in order to aid a better understanding of the characteristics of the invention, attached to the present descriptive memory and as an integral part of the same is a set of drawings where with an illustrative and non-limiting nature the following has been shown:

Figure 1 shows a sketch of the powder injection device

of the invention.

Figure 2 shows an operation sequence of the powder injection device of the invention.

5

Figure 3 shows a graph showing the evolution of pressure at the powder injection point along two firing cycles of the detonation gun.

10 Figure 4 shows a sketch of the embodiment with a double powder injection device.

PREFERRED EMBODIMENT OF THE INVENTION

15 As shown in figure 1 the system of the invention is a connection device between a continuous feeding system and a detonation gun and basically consists of an expansion and dosage chamber (2) which is reached by a direct conduct (5) by the powder supplied by a
20 continuous feeding system (7), not shown, the dosage chamber (2) being connected to the barrel (1) by a direct conduit (4).

25 The dosage chamber (2) is basically an expansion chamber which communicates with the barrel (1) of the gun through a direct tubular conduit (4) of reduced diameter, so that the pressure wave advancing through the barrel (1) passes to the communication conduit (4) and reaches the dosage chamber (2). The detonation gases
30 which reach the dosage chamber (2) undergo a sudden

expansion which fills the chamber with gas, blocking the entry of the powder feeding conduct (5). In this way it is possible to cyclically interrupt the feeding of powder from the continuous feeder (7) and thus it is possible to control the amount of powder dosed in the chamber and consequently the amount of powder injected to the barrel in each detonation cycle.

The sudden expansion of the gas in the dosage chamber (2) creates a turbulence which produces the fluidization of all the powder contained in the dosage chamber (2), so that the suction process which follows the detonation carries all the powder contained in the chamber injecting it into the barrel (1). The fluidization of the powder contained in the dosage chamber (2) is favored by the fact that the gases of the detonation wave are at a high temperature.

In this way, when the pressure wave generated by the detonation passes the communication conduct (4), the low pressure generated after the detonation wave produces a suction which carries the gas contained in chamber (2) and the powder included in it which is totally fluidized. The powder is carried to the barrel (1) where it remains until the pressure wave produced in a new detonation cycle carries it, depositing it on the substrate (3) or part to be covered.

In addition, the expansion of gases of the detonation wave inside chamber (2) produces a reduction in their

velocity, minimizing the erosion effect on the chamber (2) walls and preventing the pressure wave from advancing through conduit (5) to the powder feeding system (7).

5

Although expansion chamber (2) reduces the speed of the pressure wave, unavoidably there is interaction between the gases and the inner walls of the chamber in the area opposite the communication conduit (4) so that the impact of the pressurized gas and the fluidized powder against this area would inevitably result in severe erosion. For this reason, the dosage chamber is provided with an extension or auxiliary chamber (6) with an inlet point opposite communication conduit (4) so that the pressure shock wave expands inside the dosage chamber (2) and inside the extension (6) avoiding a violent collision of the shock wave with the walls of chamber (2).

20 The expansion chamber (2) can have any shape or size as long as the gases which enter it through conduit (4) undergo a sudden expansion as they enter the chamber. Communication conduit (4) can also have any length or diameter as long as it is great enough so that the powder does not adhere to its walls blocking it and so that the pressure of the detonation wave which travels through it is not too large, that is, as long as the pressure allows fluidization of the powder contained in the chamber but does not endanger the continuous powder feeding system nor exhausts the energy available for

30

detonation.

Figure 3 shows a graph with the pressure variations with time at the powder injection point, where a peak or sudden pressure increase (D) can be clearly seen, corresponding to the detonation, followed by a pressure drop (S) corresponding to the suction following the detonation, and then remaining more or less constant until during the following cycle a new pressure peak (D) occurs, followed by the ensuing suction (S).

With this configuration, as seen in figures 2 and 3 the operation sequence corresponding to a gun operation cycle with the injector of the invention will be the following:

- A conventional continuous powder feeding system (7) supplies powder to the dosage chamber (2) via a conduit (5). This feeding occurs continuously and directly, without any valves or closing mechanisms between the powder feeding system (7) and the dosage chamber (2).
- When the pressure wave (D) front reaches the communication opening between conduit (4) and barrel (1) part of the detonation gases enter through conduit (4) until they reach the dosage chamber (2). On reaching it these gases undergo a sudden expansion which fills the dosage chamber (2) with pressurized gas, blocking entry of powder

from conduit (5) converting the continuous powder feeding into a discontinuous filling of the dosage chamber.

5 - In addition, the sudden expansion of gases generates a turbulence which causes the fluidization of all powder contained in the dosage chamber (2), the fluidization being favored by the high temperature of the detonation gases.

10

-Once front (D) of the detonation wave has fully passed the communication orifice to the conduit (5), low pressure (S) causes a suction which carries the gases contained both in the dosage chamber (2) and in conduit (4) and therefore also the powder contained in the dosage chamber (2). In this way the powder reaches the barrel, awaiting the following pressure front (D) corresponding to the following detonation, which will carry it away with it. As all the powder contained in the dosage chamber (2) is fluidized the suction generated by the pressure wave carries all the powder in the dosage chamber (2) thus obtaining a periodic and controlled injection of powder into the barrel.

25

Finally, figure 4 shows a double device consisting of two injection systems in order to allow feeding of different types of powders at points axially separated from the barrel to obtain multiple-layer coatings or even coatings of gradient composition.

30

27395-91

- 14 -

CLAIMS:

1. A powder injection system for a detonation spray gun of the type comprising a gas supply, an ignition source, and a barrel, the system comprising:
 - 5 an expansion and dosage chamber directly fed by a continuous powder feeding device; and

means for communicating with the expansion and dosage chamber and the barrel, the means being disposed so that a first pressure associated with gases traveling down
10 the barrel, when reaching the expansion and dosage chamber, temporarily interrupts powder feeding until a subsequent lower second pressure sucks powder contained in the expansion and dosage chamber to the barrel.
2. A powder injection system for a detonation spray
15 gun as claimed in claim 1, wherein the means for communicating comprises a communication conduit, which has a reduced diameter so that any gases that advance through the communication conduit undergo expansion on reaching the expansion and dosage chamber.
- 20 3. A powder injection system for a detonation spray gun as claimed in claim 1, wherein the gas supply is a continuous supply.
4. A powder injection system for a detonation spray
25 gun as claimed in claim 1, wherein the means for communicating comprises a communication conduit, which has a sufficiently large diameter to prevent powder from adhering to inner walls of the communication conduit.
5. A powder injection system for a detonation spray gun as claimed in claim 1, wherein the barrel has an axis

27395-91

- 15 -

and the means for communicating comprises a communication conduit that is disposed radially about the axis.

6. A powder injection system for a detonation spray gun as claimed in claim 1, wherein the powder feeding device
5 further comprises a carrier gas supply.

7. A powder injection system for a detonation spray gun of the type comprising a gas supply, an ignition source, and a barrel, the system comprising:

an expansion and dosage chamber directly fed by a
10 continuous powder feeding device, wherein the expansion and dosage chamber incorporates an extension chamber, which increases the length of the expansion and dosage chamber;

a communication conduit in communication with the expansion and dosage chamber and the barrel, wherein the
15 communication conduit is disposed so that a first pressure associated with gases traveling down the barrel, when reaching the expansion and dosage chamber temporarily interrupts powder feeding until a subsequent lower second pressure sucks powder contained in the expansion and dosage
20 chamber to the barrel.

8. A powder injection system for a detonation spray gun as claimed in claim 7, wherein the extension chamber is in fluid communication with the expansion and dosage chamber at a point opposite the communication conduit.

25 9. A method for introducing powder to a detonation spray gun of the type comprising a supply of detonation gases, an ignition source, and a barrel having an open end, the method comprising:

feeding the powder into an expansion and dosage
30 chamber;

27395-91

- 16 -

feeding the detonation gases to the barrel;

igniting the detonation gases to produce a
detonation pulse;

5 passing a portion of the detonation pulse through
a communication conduit to the expansion and dosage chamber;
and

10 interrupting the feeding of powder into the
expansion and dosage chamber and drawing the powder from the
expansion and dosage chamber into the barrel with said
portion of the detonation pulse.

10. A method for introducing powder to a detonation
spray gun as claimed in claim 9, wherein the feeding
detonation gases step further comprises feeding the
detonation gases through the communication conduit in fluid
15 communication with the barrel.

11. A method for introducing powder to a detonation
spray gun as claimed in claim 9, wherein the feeding powder
into the expansion and dosage chamber step further comprises
using a powder feeding device to feed the powder into the
20 expansion and dosage chamber.

12. A method for introducing powder to a detonation
spray gun as claimed in claim 9, wherein the feeding powder
into the expansion and dosage chamber step further comprises
using a carrier gas.

25 13. A method for introducing powder to a detonation
spray gun of the type comprising a supply of detonation
gases, an ignition source, and a barrel having an open end,
the method comprising:

27395-91

- 17 -

feeding the powder into an expansion and dosage chamber;

feeding the detonation gases to the barrel;

igniting the detonation gases to produce a
5 detonation pulse;

passing a portion of the detonation pulse through a communication conduit to the expansion and dosage chamber, wherein the communication conduit is in fluid communication with the expansion and dosage chamber and the barrel,
10 wherein the portion of the detonation pulse in the expansion and dosage chamber interrupts the feeding of powder into the expansion and dosage chamber, and

drawing the powder from the expansion and dosage chamber into the barrel, wherein the feeding is solely
15 controlled by the detonation pulse.

14. A method for introducing powder to a detonation spray gun as claimed in claim 13, wherein the interruption of feeding causes cyclical feeding of the powder to the expansion and dosage chamber.

20 15. A method for introducing powder to a detonation spray gun as claimed in claim 14, wherein the detonating pulse has a frequency and wherein the cyclical feeding is synchronized with the frequency.

16. A powder injection system for a detonation spray
25 gun of the type comprising a gas supply, an ignition source, and a barrel, the system comprising:

an expansion and dosage chamber directly fed by a continuous powder feeding device, wherein the expansion and

27395-91

- 18 -

dosage chamber incorporates an auxiliary chamber, which increases the length of the expansion and dosage chamber;

a communication conduit in communication with the expansion and dosage chamber and the barrel, wherein the communication conduit is disposed so that a first pressure associated with gases traveling down the barrel, when reaching the expansion and dosage chamber temporarily interrupts powder feeding until a subsequent lower second pressure sucks powder contained in the expansion and dosage chamber to the barrel.

17. A powder injection system for a detonation spray gun as claimed in claim 16, wherein the auxiliary chamber is in fluid communication with the expansion and dosage chamber at a point opposite the communication conduit.

FETHERSTONHAUGH & CO.

OTTAWA, CANADA

PATENT AGENTS

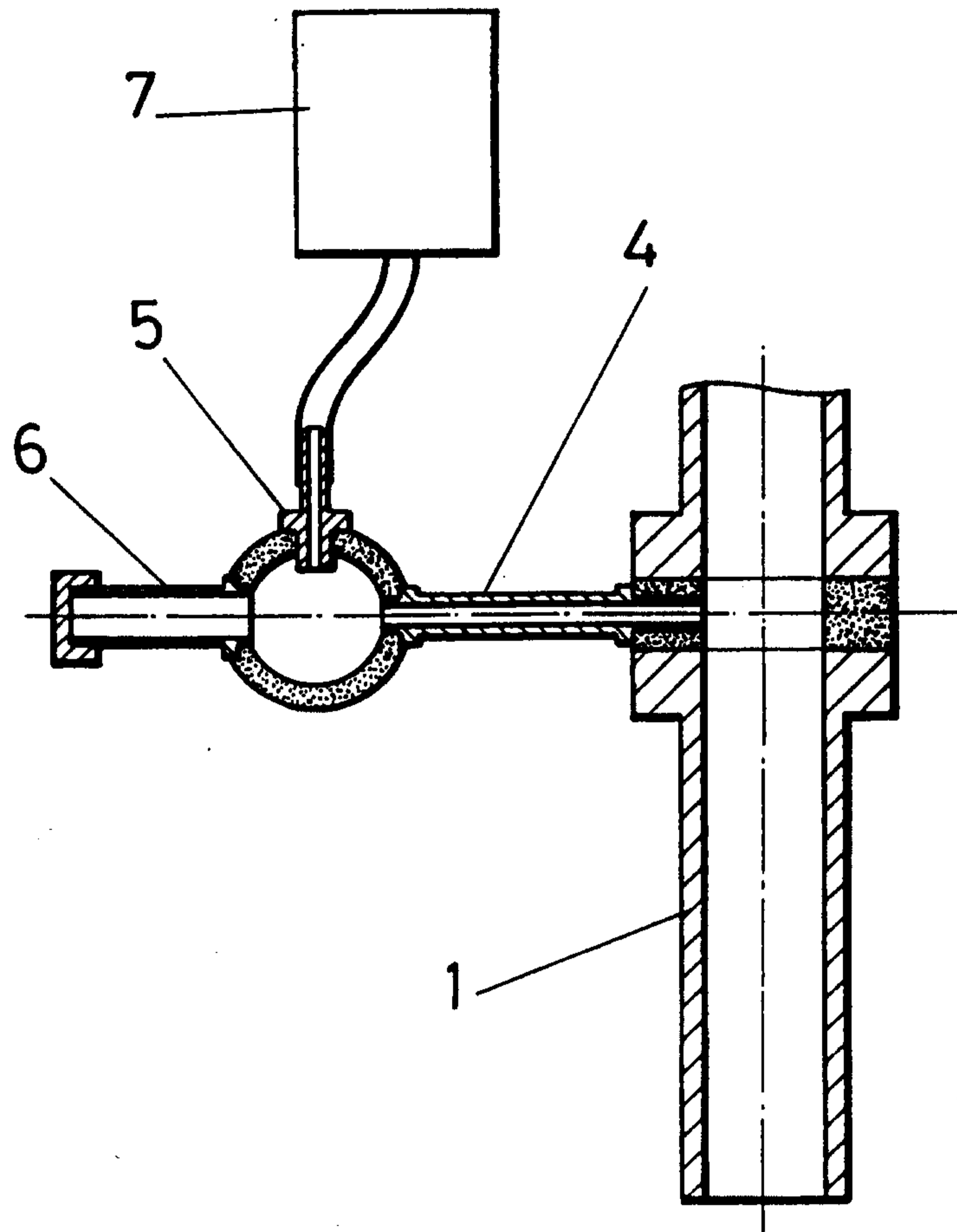

FIG.1

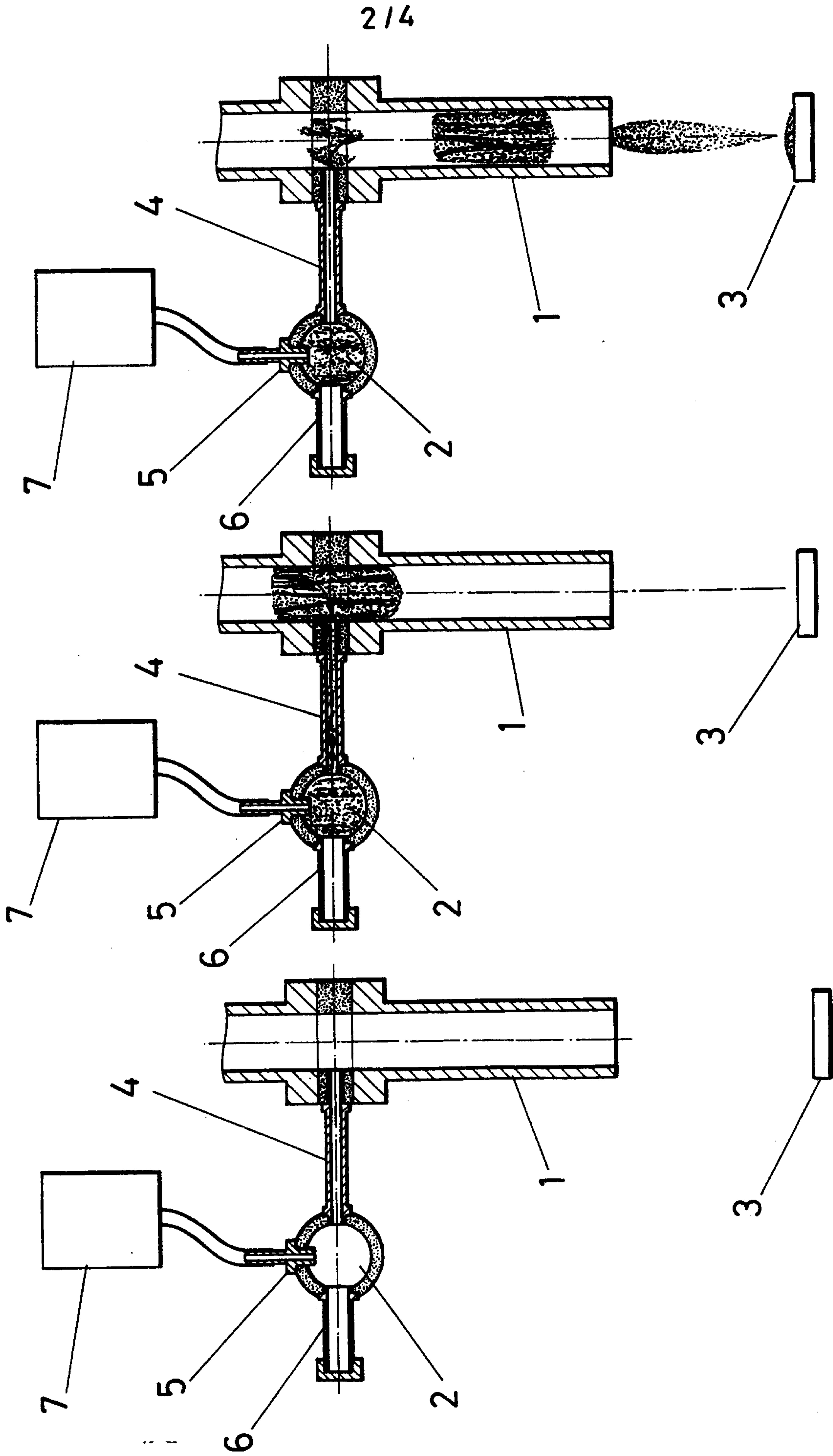
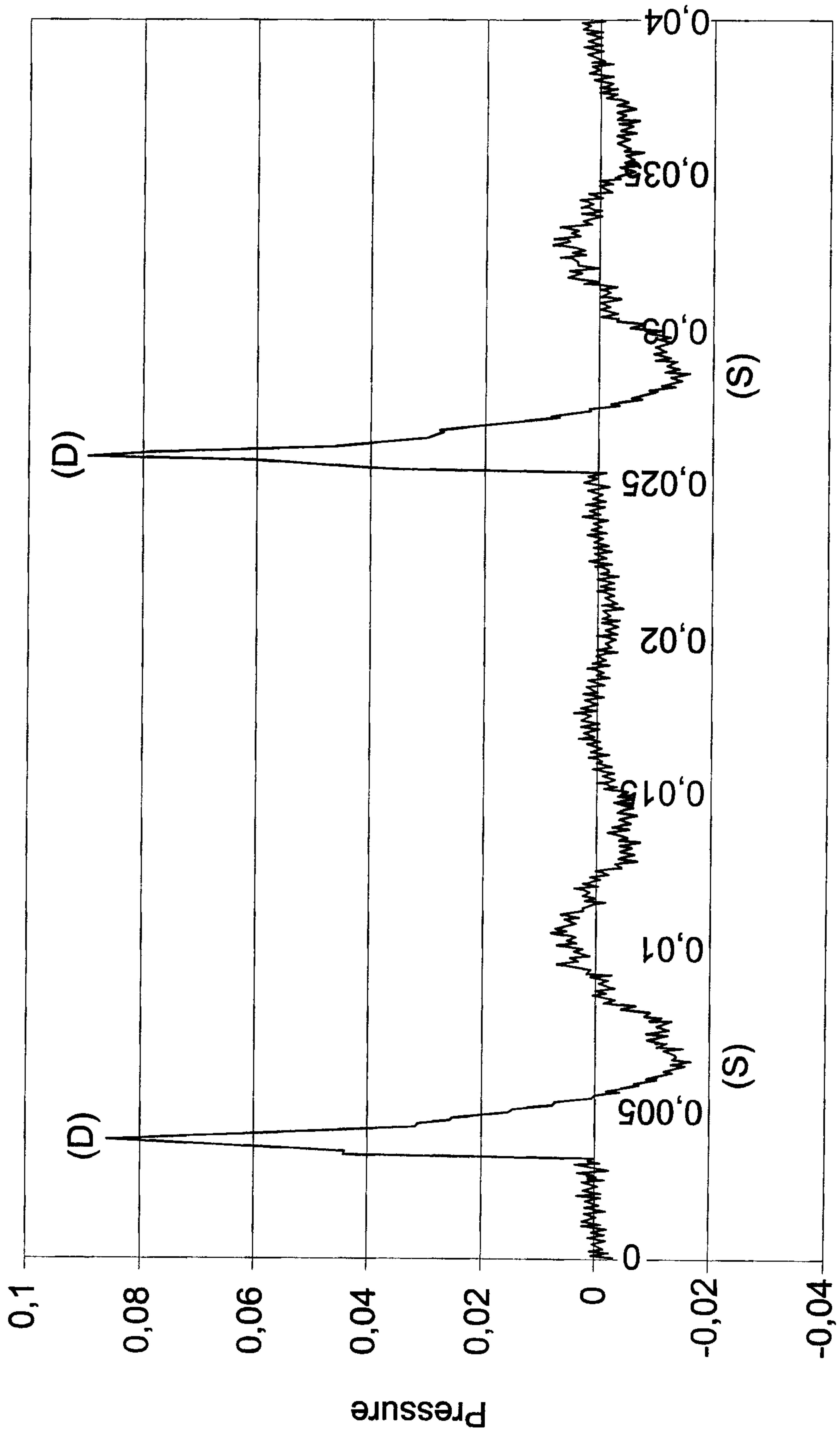

FIG.2



Time

FIG. 3

4/4

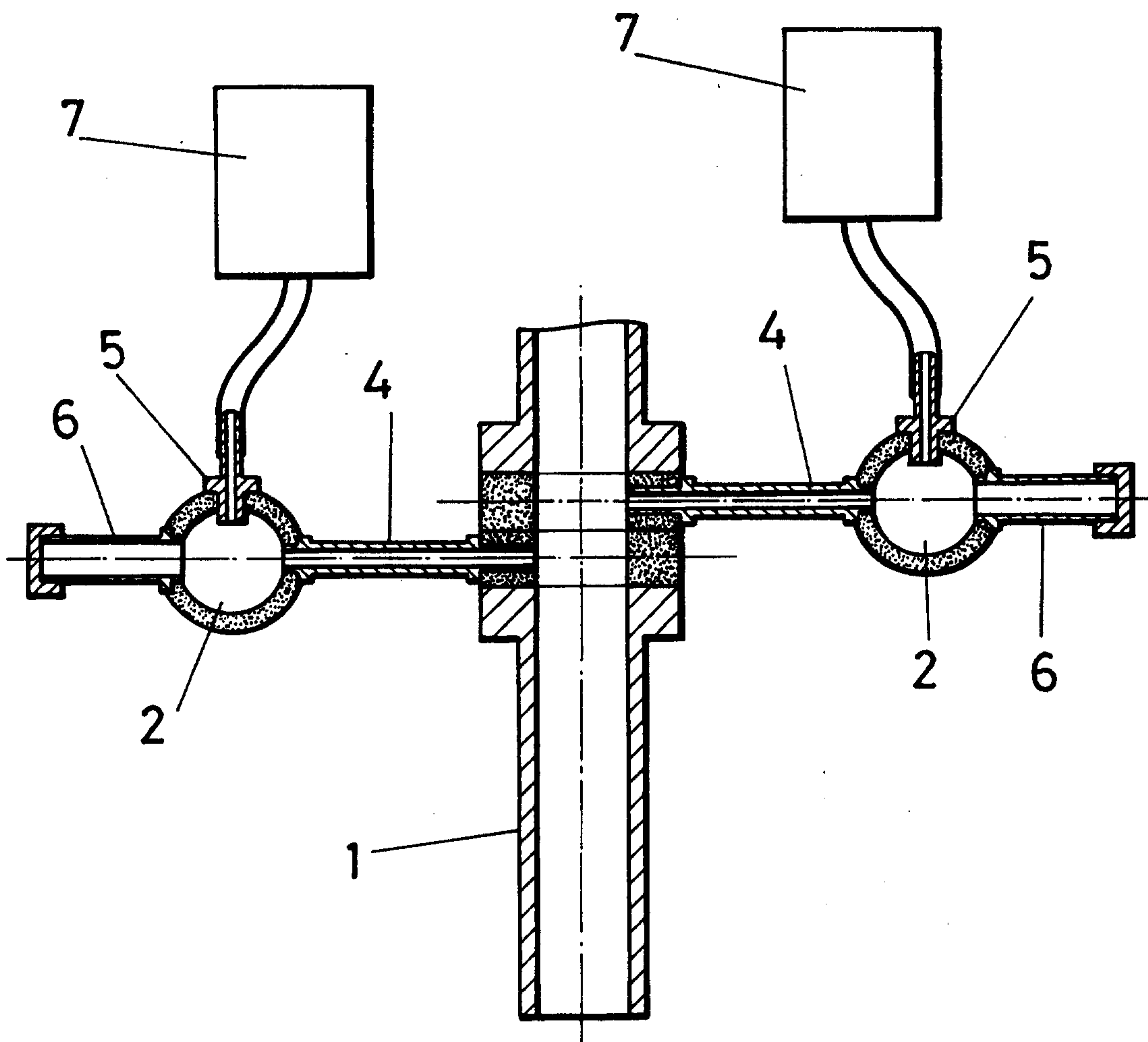

FIG.4

