

May 30, 1961

W. L. PARKER

2,985,976

WIND ROTATED ATTENTION ARRESTING SIGNAL

Filed Nov. 25, 1959

2 Sheets-Sheet 1

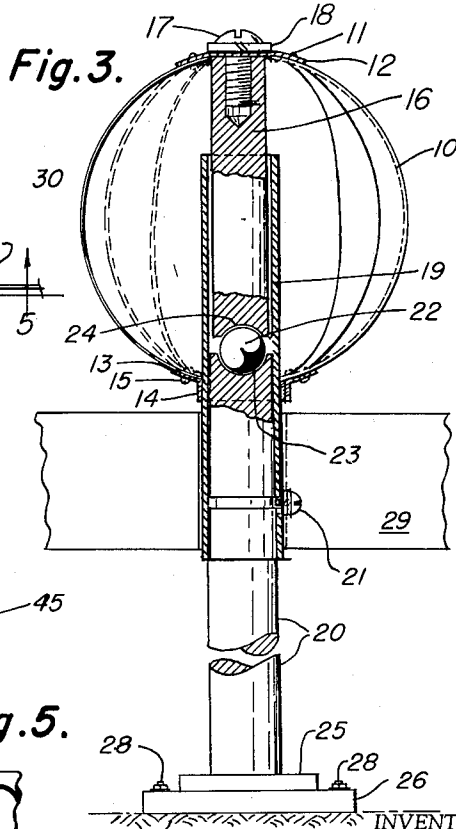
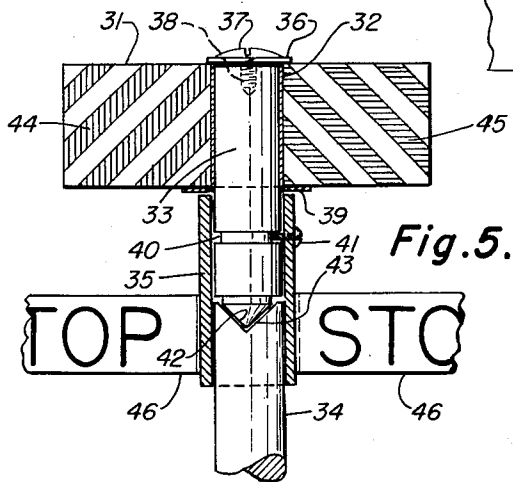
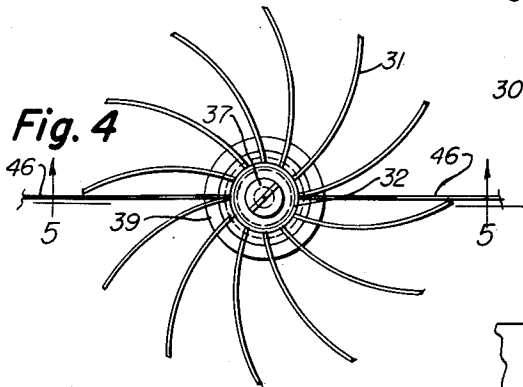
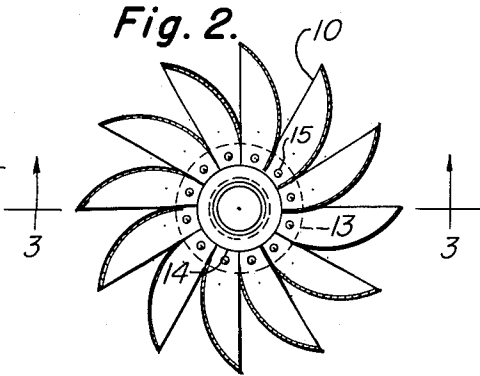
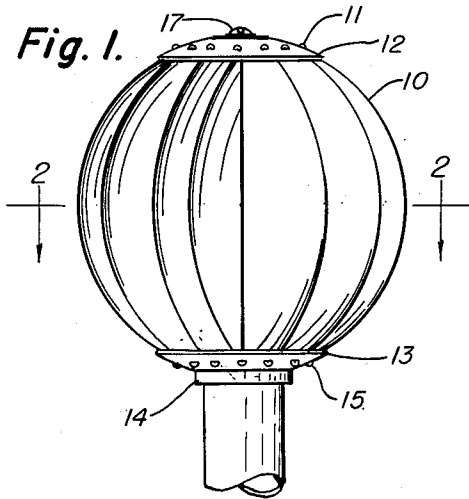

INVENTOR.
Wayne L. Parker
BY
Victor J. Evans & Co.
ATTORNEYS

May 30, 1961

W. L. PARKER

2,985,976

WIND ROTATED ATTENTION ARRESTING SIGNAL

Filed Nov. 25, 1959

2 Sheets-Sheet 2

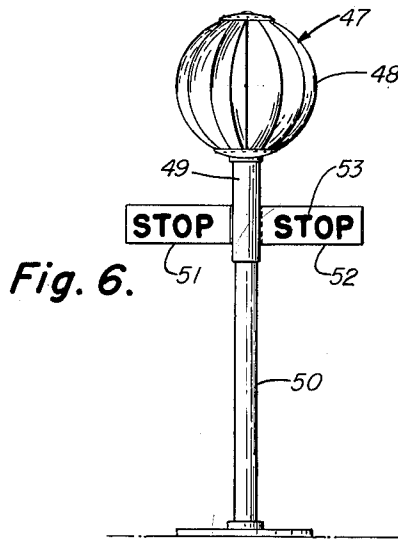

Fig. 6.

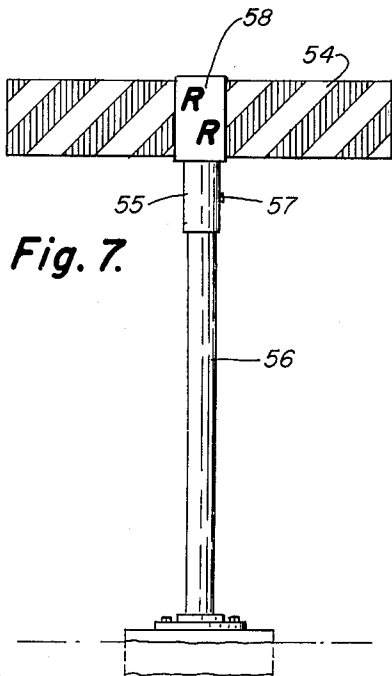

Fig. 7.



Fig. 8.

INVENTOR.
Wayne L. Parker

BY

Victor J. Evans & Co.
ATTORNEYS

1

2,985,976

WIND ROTATED ATTENTION ARRESTING SIGNAL

Wayne L. Parker, 432 S. Taylor, Pierre, S. Dak.

Filed Nov. 25, 1959, Ser. No. 855,350

1 Claim. (Cl. 40—39)

This invention relates to attention arresting signals and signs, such as slow and stop signs used on highways, street or roadway intersections, curves or turns, and schools; and in particular a wind rotatable color reflecting or Scotch lighted ball or wheel used independently or in combination with signs or signals whereby the attention of an operator of a vehicle is directed by the rotating ball or wheel to a sign or to signs.

The purpose of this invention is to improve conventional road signs by providing wind rotated elements on or in combination with such signs whereby the attention of a motorist is directed to a sign.

Various types of stationary signs are provided on roadways, at intersections of streets and highways and at other points. However, in traveling over highways and particularly in traveling the same highway day after day the stationary signs become fixtures and although the driver of a motor vehicle is conscious of the presence of a sign the contents of the sign are soon overlooked. With this thought in mind this invention contemplates a rotating element mounted on or in combination with a sign whereby the attention of an operator of a motor vehicle is arrested by the rotating element and directed to a sign in combination with said rotating element.

The object of this invention is, therefore, to provide a continuously moving element in combination with a road sign whereby the attention of all motorists traveling on a street or highway is arrested and directed to the sign.

Another object of the invention is to provide a rotatable element for a road sign in which the element is rotated by, even a very slight wind, thereby obviating the necessity of providing electric power for operating the element.

Another important object of the invention is to provide a rotatable element for directing the attention of motorists to a sign in which the element may be mounted on signs now in use.

A further object of the invention is to provide a rotatable element for use in combination with signs in which the element is of simple and economical construction.

With these and other objects and advantages in view the invention embodies a ball or wheel having a plurality of vanes in which the vanes are patterned to provide propelling means for rotating the element as air is circulated over the element.

Other features and advantages of the invention will appear from the following description taken in connection with the drawings, wherein:

Figure 1 is a side elevational view of a ball, sphere, or attentionator of other patterns showing the attentionator mounted on a tubular post with the lower part of the post broken away.

Figure 2 is a sectional plan through the ball taken on line 2—2 of Figure 1 showing the arrangement of the blades therein.

Figure 3 is a side elevational view of a sign post having a rotating ball on the upper end, the ball being shown in

2

section and the section being taken on line 3—3 of Figure 2.

Figure 4 is a plan view illustrating an attentionator of a different design wherein arcuate blades extend outwardly from a hub.

Figure 5 is a vertical section through the attentionator shown in Figure 4 being taken on line 5—5 of Figure 4 and in which the post is shown in elevation.

Figure 6 is an elevational view showing a typical application of a wind rotating element to a conventional stop sign.

Figure 7 is an elevational view showing a typical application of wind rotated blades, as shown in Figure 4, to a railroad warning sign.

Figure 8 is a view showing a typical application of the wind rotated sphere to a commercial sign, such as a barber's pole.

Referring now to the drawings wherein like reference characters denote corresponding parts the improved wind rotatable attention arrester of this invention includes a plurality of scoop-like blades 10, the upper ends of which are secured by rivets 11 to a disc 12 and the lower ends of which are secured to a flange 13 of a collar 14 by rivets 15, as illustrated in Figure 3. The disc 12 is retained on the upper end of a shaft 16 by a bolt 17 and a lock washer 18. The shaft 16 is rotatably mounted in a sleeve 19 on a post 20 and the sleeve 19 is secured to the post 20 by a bolt 21. A ball 22 is positioned in a recess 23 in the upper end of the post 20 and the upper portion of the ball extends into a recess 24 in the lower end of the shaft 16. The lower end of the post 20 is provided with a flange 25 that is positioned on a base 26 and the base may be secured to a foundation 27 by bolts 28.

The sleeve 19 may be provided with arms or vanes 29 upon which signs, such as slow, stop, or school may be placed. Inner surfaces of the scope like vanes or blades may be coated with Scotch light or a suitable reflecting coating, as indicated by the numeral 30 and the reflecting coating may be of any suitable color.

In the design illustrated in Figures 4 and 5 arcuate vanes 31 extend radially from a sleeve 32 and the sleeve is positioned over the upper end of a shaft 33 rotatably mounted on a post 34 by a sleeve 35. The sleeve 32 is provided with a closed upper end 36 and the sleeve is retained in position on the shaft 33 by a screw 37 extended through the end 36 and threaded in a socket 38 in the upper end of the shaft. The lower end of the sleeve 32 is provided with a flange 39.

The shaft 33 is provided with an annular groove 40 into which the shank of a screw 41, threaded in the sleeve 35, extends, thereby preventing accidental removal of the shaft 33 and vanes 31 from the post 34. The lower end of the shaft 33 is provided with a conical shaped tip 42 that is positioned in a similarly shaped recess 43 in the upper end of the post 34. By this means a mounting is provided whereby blades or vanes with bars 44 and 45 of reflecting material may be placed on the vanes or the vanes may be used in combination with blades 46 with the word stop, slow, or the like thereon.

In the design illustrated in Figure 6 a sphere or ball 47 having blades 48 with reflecting coatings thereon, is rotatably mounted on the upper end of a sleeve 49 of a post 50 and the ball is positioned in combination with plates 51 and 52 on which the word stop, as indicated by the numeral 53 may be positioned. The post 50 is similar to the post 20 of the design shown in Figures 1, 2 and 3.

In the design shown in Figure 7 vanes or blades 54, similar to the vanes shown in Figures 4 and 5, are mounted on a sleeve 55 secured on the upper end of a post 56 by a set-screw 57. In this design the vanes or blades extend from a cylinder or casing 58 by which the

blades are mounted on the sleeve 55 whereby a sign is provided in the center and between rotating blades.

In the design illustrated in Figure 8 a ball 59, similar to the sphere illustrated in Figures 1, 2 and 3 is provided on the upper end of a pole 60 and the pole 60 may be rotated by the ball 59 or by a train of gears 61 in a support 62 from which the pole 60 extends. The pole 60 is provided with a continuous strip 63 of reflecting material and the strip may be provided in various colors. The support 62 is provided with a horizontally disposed arm 64 with the lower end of the pole 60 rotatably mounted in a socket 65 at the outer end of the arm and the pole 60 may be secured on an inner shaft 66 by a set-screw 67. By this means the ball 69 may be rotated by the wind, similar to the ball shown in Figures 1, 2 and 3 and the pole 60 may be rotated by a motor through a train of gears or both the ball and pole may be rotated by the wind or by the train of gears, as may be desired.

It will be understood that other modifications, within the scope of the appended claim, may be made in the design and arrangement of the parts without departing from the spirit of the invention.

What is claimed is:

An attention arrester comprising a post, a sleeve mounted on the upper end of the post, means for preventing accidental separation of the sleeve from the post, said post having a recess in that end thereof that is positioned with said sleeve, a ball positioned in said recess, a shaft having a recess on one end thereof rotatably mounted in said sleeve with the ball positioned in the recess in the end of said shaft, a collar rotatably mounted on said sleeve, a disc fixed to the upper end of said shaft, radially disposed vanes secured to and extended between the collar on said sleeve, and the disc secured to said shaft, said vanes having reflecting material thereon, and a sign mounted on the sleeve below the collar thereon.

References Cited in the file of this patent

UNITED STATES PATENTS

346,197	Fagerburg	July 27, 1886
983,684	Clapp	Feb. 7, 1911
1,796,862	Crawford	Mar. 17, 1931
1,801,274	Hinks	Apr. 21, 1931
2,094,942	Frye	Oct. 5, 1937
2,417,122	Pearson	Mar. 11, 1947