



US 20140090664A1

(19) **United States**

(12) **Patent Application Publication**
Walz et al.

(10) **Pub. No.: US 2014/0090664 A1**

(43) **Pub. Date: Apr. 3, 2014**

(54) **SELF-PROPELLED SURFACE CLEANING MACHINE AND METHOD FOR OPERATING A SELF-PROPELLED SURFACE CLEANING MACHINE**

(52) **U.S. Cl.**
CPC *A47L 11/4066* (2013.01); *A47L 11/4061* (2013.01); *A47L 11/4069* (2013.01); *A47L 11/28* (2013.01); *A47L 11/24* (2013.01)
USPC .. *134/6*; *180/65.1*; *180/178*; *15/49.1*; *15/50.1*

(71) Applicant: **Alfred Kärcher GmbH & Co. KG**, Winnenden (DE)

(72) Inventors: **Juergen Walz**, Moeckmuehl (DE); **Christian Hofner**, Welzheim (DE)

(57) **ABSTRACT**

(73) Assignee: **Alfred Kärcher GmbH & Co. KG**, Winnenden (DE)

(21) Appl. No.: **14/100,139**

(22) Filed: **Dec. 9, 2013**

Related U.S. Application Data

(63) Continuation of application No. PCT/EP2011/059681, filed on Jun. 10, 2011.

Publication Classification

(51) **Int. Cl.**
A47L 11/40 (2006.01)
A47L 11/24 (2006.01)
A47L 11/28 (2006.01)

Provided is a self-propelled surface cleaning machine including a front wheel device, a steering device associated therewith, a steering angle sensor device capable of detecting a steering angle at the front wheel device, a rear wheel device having a left rear wheel and a right rear wheel, an electromotive drive device associated with each of the left rear wheel and the right rear wheel, a cleaning liquid application device by which cleaning liquid is applicable to a floor/ground in an application area arranged between the front wheel device and the rear wheel device, and a control device operatively connected for signal communication with the steering angle sensor device and the electromotive drive devices, wherein each electromotive drive device is controllable individually depending on signals from the steering angle sensor device.

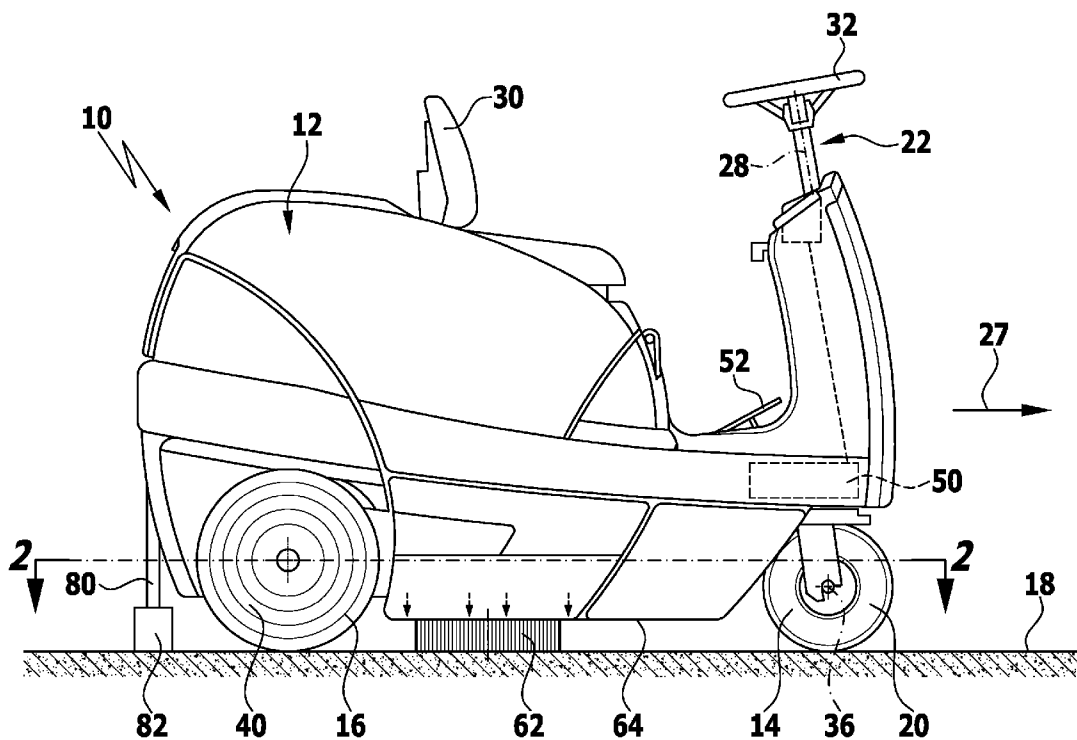

FIG. 2

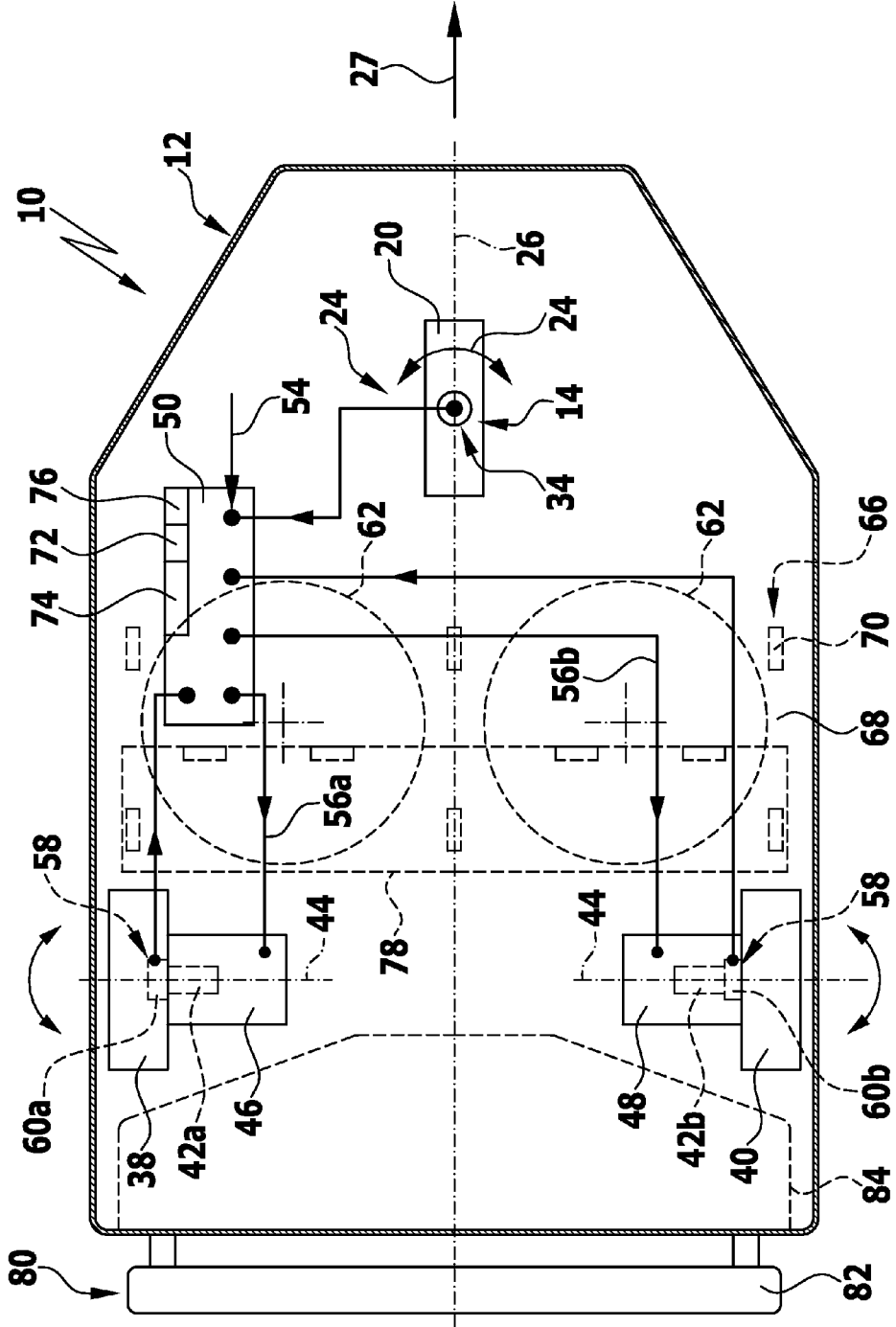
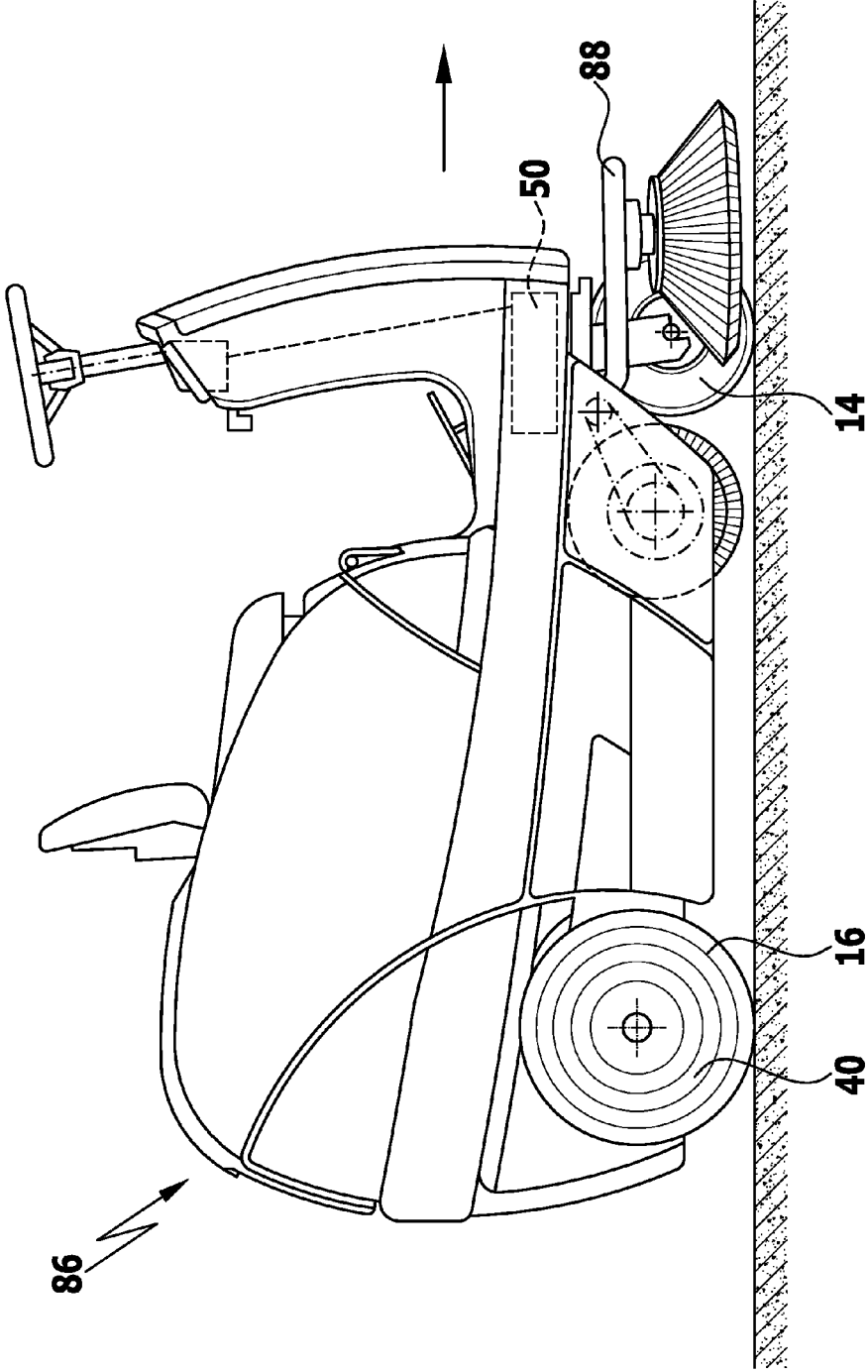

FIG. 3



SELF-PROPELLED SURFACE CLEANING MACHINE AND METHOD FOR OPERATING A SELF-PROPELLED SURFACE CLEANING MACHINE

CROSS-REFERENCE TO RELATED APPLICATIONS

[0001] This application is a continuation of international application number PCT/EP2011/059681, filed on Jun. 10, 2011, which is incorporated herein by reference in its entirety and for all purposes.

BACKGROUND OF THE INVENTION

[0002] The invention relates to a self-propelled surface cleaning machine.

[0003] The invention further relates to a method for operating a self-propelled surface cleaning machine comprising a steered front wheel device and a driven rear wheel device.

[0004] DE 10 2004 022 359 A1 discloses a mobile surface cleaning machine comprising a drive unit for propelling the surface cleaning machine and comprising at least one cleaning tool, wherein the at least one cleaning tool and/or the drive unit has a plurality of operating modes and wherein a particular mode of operation is selectable by the user by way of operator controls.

[0005] EP 1 239 762 B1 discloses a movable carriage, in particular a working machine or surface cleaning machine, comprising at least one pivotable wheel and/or a pivotable actuating, working or cleaning unit and at least one sensor device. The sensor device is arranged such that it is, at least relatively, co-pivotable with the at least one steerable wheel and/or the pivotable actuating, working or cleaning unit in the same pivoting direction.

[0006] DE 30 43 004 C2 discloses an electric single wheel drive.

[0007] DE 694 02 303 T2 discloses an electric drive assembly comprising an electric differential drive axis.

[0008] U.S. Pat. No. 5,487,738 discloses a drive system for an electric vehicle.

SUMMARY OF THE INVENTION

[0009] In accordance with the invention a self-propelled surface cleaning machine having a high level of driving safety is provided.

[0010] In accordance with an embodiment of the invention, the self-propelled surface cleaning machine comprises:

- [0011] a front wheel device;
- [0012] a steering device associated with the front wheel device;
- [0013] a steering angle sensor device by which a steering angle at the front wheel device is capable of being detected;
- [0014] a rear wheel device having at least one left rear wheel and at least one right rear wheel;
- [0015] a first electromotive drive device associated with the at least one left rear wheel;
- [0016] a second electromotive drive device associated with the at least one right rear wheel;
- [0017] a cleaning liquid application device by which cleaning liquid is capable of being applied to a floor/ground in an application area that is arranged between the front wheel device and the rear wheel device; and

[0018] a control device operatively connected for signal communication with the steering angle sensor device, the first electromotive drive device and the second electromotive drive device, wherein each of the first electromotive drive device and the second electromotive drive device is capable of being controlled individually depending on signals from the steering angle sensor device.

[0019] In accordance with an embodiment of the invention, increased driving safety is reached, particularly also when travelling on wet floor/ground and when running uphill. Arranging the application area between the front wheel device and the rear wheel device results in a high level of cleaning efficiency, while ensuring that in forward travel (in a direction of the velocity vector from the rear wheel device to the front wheel device), the steered front wheel device runs in a non-application area ("dry area"). The driven rear wheel device then runs in an application area ("wet area"). The traction that is obtained in said "wet area" may in principle be worse compared to that obtained in the area in which the front wheel device is run; this is particularly true where the cleaning liquid contains chemical additives such as soft soap which increase the slipperiness of the floor/ground.

[0020] In the solution in accordance with the invention, the first electromotive drive device and the second electromotive drive device are controlled individually, i.e., independently of each other, when required. The result is that optimized adaptation to the ground conditions is obtained even in cornering. Traction can be increased. This in turn allows for an optimized speed to be adjusted, adapted to the ground conditions. This results in time-effective cleaning with high driving safety.

[0021] By controlling the first electromotive drive device and the second electromotive drive device individually in cornering and in particular by adjusting different rotational speeds in cornering, it is possible to ensure an optimized work result.

[0022] The control device comprises in particular an electronic differential device for the at least left rear wheel and the at least one right rear wheel. An optimized adjustment, adapted to the existing ground conditions, can thereby be obtained in cornering, in order to achieve enhanced driving safety with optimized speed.

[0023] In an embodiment, provision is made for the first electromotive drive device and/or the second electromotive drive device to comprise a transverse flux motor. With use of such a motor as a single wheel drive, it is possible to implement high efficiency with a wide torque range.

[0024] In an embodiment of advantageous design, the front wheel device comprises one or more steering rollers. A (non-driven) steering roller provides for stable tracking. Steering can be implemented in a simple manner.

[0025] It is advantageous for the control device to comprise a speed limiting device, wherein a maximum speed is dependent on the steering angle. Increased driving safety can thereby be achieved. Furthermore, by making use of an in particular predetermined maximum speed, time-effective cleaning of a floor/ground area can be achieved.

[0026] Control parameters of the control device for the first electromotive drive device and the second electromotive drive device may comprise rotational speed and direction of rotation. By way of example, when turning a narrow corner (for example a turn through a steering angle of 90°), it may be

advantageous for the inside rear wheel to be adjusted so as to rotate in a direction counter to that of the outside rear wheel.

[0027] It is further advantageous for the rear wheel device to have a sensor device associated with it, said sensor device sensing wheel parameters and in particular slip-determined wheel parameters, and for the sensor device to be operatively connected for signal communication with the control device. It is thereby possible to perform anti-slip control when corresponding slip-determined parameters are sensed.

[0028] In this connection, it is advantageous for the control device to comprise an anti-slip control.

[0029] In particular, one or more nozzles for cleaning liquid are provided, said nozzles being arranged between the front wheel device and the rear wheel device. An application area can thereby be formed which is arranged between the front wheel device and the rear wheel device. By way of the nozzles, water or a water/additive mixture can be applied, for example.

[0030] In particular, in forward travel, applying cleaning liquid to the floor/ground to be cleaned is effected behind the front wheel device and in front of the rear wheel device. This allows steering on the front wheel device to be performed in a non-application area ("dry area"). Drive is effected in the application area.

[0031] It is further advantageous for one or more scrubbing elements to be provided, said scrubbing elements being arranged in particular between the front wheel device and the rear wheel device. Effective cleaning can thereby be achieved. Cleaning liquid from a nozzle can be applied directly to the scrubbing element(s) and/or it can be sprayed directly onto a floor/ground surface.

[0032] For example, a surface cleaning machine is configured as a scrubbing machine and in particular as a scrubber vacuum machine. A scrubber vacuum machine sucks up excess cleaning liquid after scrubbing.

[0033] It is in principle possible for a self-propelled surface cleaning machine constructed in accordance with the invention to be attendant-controlled, for example by a driver. It is also possible for the self-propelled surface cleaning machine to be remote controlled or to be configured as a cleaning robot.

[0034] Further provided in accordance with the invention is a self-propelled surface cleaning machine, in particular sweeping machine, comprising a front wheel device, a steering device associated with the front wheel device, a steering angle sensor device by which a steering angle at the front wheel device is capable of being detected, a rear wheel device having at least one left rear wheel and at least one right rear wheel, a first electromotive drive device associated with the at least one left rear wheel, a second electromotive drive device associated with the at least one right rear wheel, and a control device operatively connected for signal communication with the steering angle sensor device, the first electromotive drive device and the second electromotive drive device, wherein each of the first electromotive drive device and the second electromotive drive device can be controlled individually depending on signals from the steering angle sensor device.

[0035] In such a self-propelled surface cleaning machine, in particular when it is configured as a sweeping machine, no provision is made for applying cleaning liquid between the front wheel device and the rear wheel device. Such a self-propelled surface cleaning machine can be operated with increased driving safety. For example when driving over wet leaves, optimized operation can be implemented by the indi-

vidually independent control of the first electromotive drive device and the second electromotive drive device.

[0036] In accordance with an embodiment of the invention, a method for operating a self-propelled surface cleaning machine having a steered front wheel device and a driven rear wheel device is provided, wherein a floor/ground to be cleaned has cleaning liquid applied thereto and an application area is located between the front wheel device and the rear wheel device, said method achieving optimized driving safety.

[0037] In accordance with an embodiment of the invention, a first drive device associated with a left rear wheel and a second drive device associated with a right rear wheel is controlled individually depending on a steering angle at the front wheel device.

[0038] The method in accordance with the invention has the advantages that have already been explained in connection with the description of the surface cleaning machine constructed in accordance with the invention.

[0039] Further advantageous embodiments have likewise already been described in connection with the description of the surface cleaning machine constructed in accordance with the invention.

[0040] In the method in accordance with the invention, steering on the front wheel device is effected outside of the application area, i.e., in a "dry area". Drive of the rear wheel device is effected in an application area, i.e., in a "wet area". By the independent and individual control capability of the first drive device and the second drive device and hence the independent control of the left rear wheel and the right rear wheel, optimized traction, adapted to the ground, can be achieved, particularly also in cornering.

[0041] In accordance with an embodiment of the invention, there is provided a method for operating a self-propelled surface cleaning machine, and in particular for operating a self-propelled sweeping machine, having a steered front wheel device and a driven rear wheel device, said method achieving optimized driving safety.

[0042] In accordance with an embodiment of the invention, a first drive device associated with a left rear wheel and a second drive device associated with a right rear wheel are controlled individually depending on a steering angle at the front wheel device.

[0043] The method in accordance with the invention has the advantages that have already been explained in connection with the description of the surface cleaning machine, in particular sweeping machine, constructed in accordance with the invention.

[0044] In particular, the rear wheel device is electromotively driven, with an electronic differential device being used for the first drive device and the second drive device. By way of the first drive device and the second drive device, wheel motors are provided that are capable of being controlled independently of each other, wherein differential control is capable of being performed, adapted to the respective steering angle and also adapted to the ground.

[0045] In particular, the first drive device and the second drive device are controlled in respect of rotational speed and direction of rotation. It may also be advantageous for a maximum speed to be predetermined, said maximum speed depending on the steering angle.

[0046] The following description of preferred embodiments serves to explain the invention in greater detail in conjunction with the drawings.

BRIEF DESCRIPTION OF THE DRAWINGS

[0047] FIG. 1 is a schematic representation of a first exemplary embodiment of a surface cleaning machine constructed in accordance with the invention;

[0048] FIG. 2 is a sectional view taken along line 2-2 of FIG. 1; and

[0049] FIG. 3 is a schematic side view of a second exemplary embodiment of a surface cleaning machine.

DETAILED DESCRIPTION OF THE INVENTION

[0050] A first exemplary embodiment of a self-propelled surface cleaning machine constructed in accordance with the invention, shown in FIGS. 1 and 2 and designated at 10, is attendant-controlled. The surface cleaning machine 10 has a body 12. Mounted to the body 12 are a front wheel device 14 and a rear wheel device 16. Via the front wheel device 14 and the rear wheel device 16, the surface cleaning machine 10 can drive on a floor/ground 18 that is to be cleaned.

[0051] In an exemplary embodiment, the front wheel device 14 comprises a steering roller 20. The steering roller 20 is connected to a steering device generally designated at 22. By way of the steering device 22, an angular position (indicated by reference numeral 24 in FIG. 2) of the steering roller 20 relative to a central axis 26 of the surface cleaning machine 10 can be adjusted. In straight ahead travel (indicated by the reference numeral 27 in FIGS. 1 and 2), the steering roller 20 is oriented parallel to the central axis 26 and a corresponding steering angle is a zero angle.

[0052] The steering device 22 defines a steering axis 28. Said steering axis 28 preferably intersects the central axis 26. The steering axis 28 is oriented transversely and for example perpendicularly to the central axis 26.

[0053] Arranged on the body 12 is a seat 30 for a driver. A driver sitting on the seat 30 can operate a steering wheel 32 of the steering device 22.

[0054] The surface cleaning machine 10 comprises a steering angle sensor device 34. By way of said sensor device, a steering angle at the front wheel device 14 (in particular an angular position of the steering roller 20 relative to the central axis 26) is capable of being detected.

[0055] The steering device comprises for example a mechanical steering rod which connects the steering roller 20 and the steering wheel 32. In particular, the steering angle sensor device 34 then detects an angular position of the steering wheel 32 or the steering rod.

[0056] Alternatively, it is for example also possible for the steering device 22 to comprise steering rods with a gear interposed therebetween. One steering rod is connected to the steering wheel 32 and another steering rod is connected to the steering roller 20. A gear interposed therebetween provides for rotational angle reduction or rotational angle increase. The gear can also be connected to the steering wheel 32 directly or connected to the steering roller 20 directly.

[0057] It is for example also possible for the steering device 22 to comprise a steering motor; a steering position of the steering roller 20 is then controlled by motor.

[0058] The steering roller 20 is capable of being rotated about a rotation axis 36 transverse to the central axis 26. In straight ahead travel in the straight ahead travel direction 27, the rotation axis 36 is oriented perpendicularly to the central axis 26.

[0059] The rear wheel device 16 comprises (at least) one left rear wheel 38 and (at least) one right rear wheel 40 (with

respect to straight ahead travel) (FIG. 2). The left rear wheel 38 is fitted on a shaft 42a. The right rear wheel is fitted on a shaft 42b. The shafts 42a and 42b have coaxial axes of rotation 44 transverse and in particular perpendicular to the central axis 26. The rear wheels 38 and 40 are unsteered, i.e., their axes of rotation 44 are fixed relative to the central axis 26.

[0060] The left rear wheel 38 has a first electromotive drive device 46 associated with it. Said first electromotive drive device 46 comprises a wheel motor which drives the left rear wheel 38 directly.

[0061] The first electromotive drive device 46 comprises for example a transverse flux motor.

[0062] The right rear wheel 40 has a second electromotive drive device 48 associated with it. This likewise comprises a wheel motor, said wheel motor driving the right rear wheel 40 directly.

[0063] The second electromotive drive device 48 likewise preferably comprises a transverse flux motor.

[0064] The surface cleaning machine 10 comprises a control device 50. The steering angle sensor device 34 is operatively connected for signal communication with said control device 50; it sends its signals (detected steering angles) to the control device 50 for further processing.

[0065] The surface cleaning machine 10 comprises corresponding actuating pedals 52 for a driver, in particular an “accelerator pedal” and a “brake pedal”. Actuating the “accelerator pedal” allows the speed to be increased, while actuating the “brake pedal” effects deceleration. The corresponding pedals are operatively connected for signal communication (indicated by reference numeral 54 in FIG. 2) with the control device 50. A corresponding position of these pedals causes the first electromotive drive device 46 and the second electromotive drive device 48 to be correspondingly controlled via the control device 50. To this end, these are operatively connected for signal communication with the control device 50; this is denoted by reference numerals 56a and 56b in FIG. 2. The control device 50 provides corresponding control signals to the first electromotive drive device 46 and the second electromotive drive device 48. In particular, the corresponding control signals cause adjustment of the rotational speed and also of the direction of rotation at each of the left rear wheel 38 and the right rear wheel 40. Brake pedal application effects deceleration, and a corresponding brake is actuated.

[0066] The rear wheel device 16 has associated with it a sensor device that is generally designated at 58 and senses wheel parameters, in particular wheel parameters characteristic of slip. To this end, the sensor device 58 comprises a first part 60a which is associated with the left rear wheel 38 and a second part 60b which is associated with the right rear wheel 40. By way of example, the sensor device 58 is used to determine the actual rotational speeds of the left rear wheel 38 and the right rear wheel 40. By comparing these values to the rotational speeds predetermined for the electromotive drive devices 46, 48 by the control device 50, it is then possible to determine whether or not a slip condition is present.

[0067] The sensor device 58 is operatively connected for signal communication with the control device 50. Corresponding sensor signals are transmitted thereto for further processing.

[0068] The surface cleaning machine 10 is configured as a scrubbing machine and in particular as a scrubber vacuum machine. It comprises one or more scrubbing elements 62, in particular scrubbing discs. These are arranged on an underside 64 of the surface cleaning machine 10, facing the floor/

ground **18**. A scrubbing element **62** is mounted, for example rotatably mounted, between the rear wheel device **16** and the front wheel device **14**.

[0069] The surface cleaning machine **10** comprises an application device **66** for cleaning liquid via which a cleaning liquid, in particular a mixture of water and added chemical, is capable of being applied in an application area **68** to the floor/ground **18** to be cleaned.

[0070] To this end, the application device **66** comprises in particular a plurality of nozzles **70** via which the cleaning liquid is capable of being applied to the application area **68**.

[0071] The nozzles **70** can be arranged in one or more rows.

[0072] The nozzles **70** can be arranged and configured such that the cleaning liquid is sprayed directly onto the scrubbing element(s) **62** (tool(s)), from where it gets to the floor/ground, and/or such that it is sprayed directly onto the floor/ground **18**.

[0073] The application area **68** is between the front wheel device **14** and the rear wheel device **16**. This means that when operating in cleaning travel, the front wheel device **14** travels in an area that has no cleaning liquid applied thereto (“dry area”), while the rear wheel device **16** travels in an area of the floor/ground **18** that does have cleaning liquid applied thereto, i.e., in the “wet area” (where chemical additives may be present).

[0074] The control device **50** comprises an electronic differential device **72**. By way of the electronic differential device **72**, the corresponding drive devices **46, 48** for the left rear wheel **38** and the right rear wheel **40** can be controlled differently from each other if required. In particular, control is effected individually depending on the steering angle detected by the sensor device **34**. For example, when turning a corner, the left rear wheel **38** or the right rear wheel **40** is made to travel faster than the other one, depending on the steering position at the front wheel device **14**.

[0075] When turning the steering wheel through a large angle (for example a turn with a 90° steering angle), the left rear wheel **38** and the right rear wheel **40** may even be made to rotate in opposite senses.

[0076] The first electromotive drive device **46** and the second electromotive drive device **48** are controlled individually, i.e., independently of each other, via the differential device **72** of the control device **50**. In principle, the front wheel device **14** is tracking.

[0077] High cornering speeds can thereby be achieved. Furthermore, increased driving safety on wet floor/ground can be achieved (it is the driven rear wheel device **16** that moves in the “wet area”). Increased driving safety in uphill driving is also provided. Steering is effected in the “dry area”, and control of the rear wheel device **16** is effected in the “wet area”. Cleaning liquid is applied behind the front wheel device **14** and in front of the rear wheel device **16**.

[0078] Anti-slip control can be implemented via the sensor device **58**. To this end, the control device **50** comprises an anti-slip control **74**. This is used to determine from signals of the sensor device **58** whether or not a slip condition is present. In particular, if slip is present, the rotational speed may be increased by corresponding control of the drive devices **46, 48**.

[0079] The control device **50** further comprises a speed limiting device **76**. The anti-slip control **74** may be part of the speed limiting device **76**. The speed limiting device **76** limits the speed to a predetermined value, depending on the steering

angle, and this can be accomplished, particularly in cornering, by differential control of the electromotive drive devices **46** and **48**.

[0080] Integrated in the surface cleaning machine **10** is a tank **78** for cleaning liquid. Provision may be made for the tank **78** to comprise a portion for holding for example water and a portion for holding chemical additives. Via the tank **78** or a mixing portion thereof, the nozzles **70** are supplied with cleaning liquid.

[0081] Furthermore, the surface cleaning machine **10** may comprise a suction device **80** via which excess liquid is capable of being sucked up from the floor/ground **18**. The suction device **80** comprises for example a suction bar **82** which is in contact with the floor/ground **18** when operating in cleaning mode. Liquid is sucked up via said suction bar **82** and received in a tank **84**. The tank **84** is a dirty water tank.

[0082] By way of example, the suction bar **82** is arranged rearward of the rear wheel device **16** relative to a forward travel direction.

[0083] In operation of the surface cleaning machine **10** in which steering on the front wheel device **14** is effected in the dry area of the floor/ground **18** and control of the rear wheel device **16** is effected in the wet area of the floor/ground **18**, the first electromotive drive device **46** and the second electromotive drive device **48** are differentially controlled depending on the detected steering angle at the front wheel device **14**. Improved traction can thereby be achieved. In particular when travelling on slippery surfaces, breakaway in cornering can be prevented by corresponding control action. Via the first electromotive drive device **46** and the second electromotive drive device **48**, the left rear wheel **38** and the right rear wheel **40** can be braked individually and independently of each other, or different rotational speeds can be adjusted.

[0084] The improved traction, in particular on slippery surfaces, is improved by sensing corresponding wheel parameters by the sensor device **58**.

[0085] Relatively high cornering speeds can thereby be achieved, adapted to the conditions encountered.

[0086] It is preferred that an additional brake device be provided which is formed by way of a frictional cone for example, in order to achieve a high braking effect.

[0087] The solution in accordance with the invention allows the optimal speed to be achieved, depending on the ground conditions encountered; cleaning liquid, in particular one containing soft soap, can make the floor/ground **18** slippery. The solution in accordance with the invention ensures that steering guidance by the front wheel device **14** is effected in the “dry area”, i.e., forward of the application area **68**.

[0088] A second exemplary embodiment of a surface cleaning machine constructed in accordance with the invention, shown schematically in FIG. 3 and indicated therein at **86**, is a sweeping machine. Said sweeping machine comprises one or more sweeping heads **88**. This sweeping machine **86** in its basic configuration is described for example in DE 10 2004 022 359 A1, which is incorporated herein and made a part hereof by reference in its entirety and for all purposes.

[0089] The surface cleaning machine **86** comprises a front wheel device **14** and a rear wheel device **16** corresponding to those of the surface cleaning machine **10**, wherein the rear wheel device **16** in turn comprises separate electromotive drive devices **46, 48** for a left rear wheel **38** and a right rear wheel **40**.

[0090] The surface cleaning machine 86 is provided with a control device 50 corresponding to the control device 50 on the surface cleaning machine 10; like reference designations indicate like elements.

[0091] By way of the control device 50, the left rear wheel 38 and the right rear wheel 40 of the surface cleaning machine 86 are controlled individually depending on a steering angle at the front wheel device 14.

[0092] In the surface cleaning machine 86, no application device 66 is provided between the front wheel device 14 and the rear wheel device 16.

[0093] Improved traction on “slippery” grounds, particularly in cornering and uphill driving, can also be achieved with the sweeping machine 86. For example, when the surface cleaning machine 86 runs on wet leaves, enhanced driving safety can be provided by controlling the left rear wheel 38 and the right rear wheel 40 individually depending on the steering angle position.

[0094] The surface cleaning machine 86 may also be configured for example as a scrubbing machine in which an application device is provided, wherein the application area (relative to a forward travel direction) is positioned in front of the front wheel device 14 or behind the rear wheel device 16.

LIST OF REFERENCE CHARACTERS

- [0095] 10 surface cleaning machine
- [0096] 12 body
- [0097] 14 front wheel device
- [0098] 16 rear wheel device
- [0099] 18 floor/ground
- [0100] 20 steering roller
- [0101] 22 steering device
- [0102] 24 angular position
- [0103] 26 central axis
- [0104] 27 straight ahead travelling direction
- [0105] 28 steering axis
- [0106] 30 seat
- [0107] 32 steering wheel
- [0108] 34 steering angle sensor device
- [0109] 36 axis of rotation
- [0110] 38 left rear wheel
- [0111] 40 right rear wheel
- [0112] 42a shaft
- [0113] 42b shaft
- [0114] 44 axes of rotation
- [0115] 46 first electromotive drive device
- [0116] 48 second electromotive drive device
- [0117] 50 control device
- [0118] 52 actuating pedals
- [0119] 54 operative connection for signal communication
- [0120] 56a operative connection for signal communication
- [0121] 56b operative connection for signal communication
- [0122] 58 sensor device
- [0123] 60a first part
- [0124] 60b second part
- [0125] 62 scrubbing element
- [0126] 64 underside
- [0127] 66 application device
- [0128] 68 application area
- [0129] 70 nozzle
- [0130] 72 differential device
- [0131] 74 anti-slip control
- [0132] 76 speed limiting device
- [0133] 78 tank

- [0134] 80 suction device
- [0135] 82 suction bar
- [0136] 84 tank
- [0137] 86 surface cleaning machine
- [0138] 88 sweeping head

1. A self-propelled surface cleaning machine, comprising:
 - a front wheel device;
 - a steering device associated with the front wheel device;
 - a steering angle sensor device by which a steering angle at the front wheel device is detectable;
 - a rear wheel device having at least one left rear wheel and at least one right rear wheel;
 - a first electromotive drive device associated with the at least one left rear wheel;
 - a second electromotive drive device associated with the at least one right rear wheel;
 - a cleaning liquid application device by which cleaning liquid is applicable to a floor/ground in an application area that is arranged between the front wheel device and the rear wheel device; and
 - a control device operatively connected for signal communication with the steering angle sensor device, the first electromotive drive device and the second electromotive drive device,
 wherein each of the first electromotive drive device and the second electromotive drive device is controllable individually depending on signals from the steering angle sensor device.

2. The self-propelled surface cleaning machine in accordance with claim 1, wherein the control device comprises an electronic differential device for the at least left rear wheel and the at least one right rear wheel.

3. The self-propelled surface cleaning machine in accordance with claim 1, wherein the front wheel device comprises one or more steering rollers.

4. The self-propelled surface cleaning machine in accordance with claim 1, wherein the control device comprises a speed limiting device, wherein a maximum speed is dependent on the steering angle.

5. The self-propelled surface cleaning machine in accordance with claim 1, wherein control parameters of the control device for the first electromotive drive device and the second electromotive drive device comprise rotational speed and direction of rotation.

6. The self-propelled surface cleaning machine in accordance with claim 1, wherein the rear wheel device has a sensor device associated with it, said sensor device sensing wheel parameters, and wherein the sensor device is operatively connected for signal communication with the control device.

7. The self-propelled surface cleaning machine in accordance with claim 6, wherein the control device comprises an anti-slip control.

8. The self-propelled surface cleaning machine in accordance with claim 1, wherein one or more nozzles for cleaning liquid are provided, said nozzles being arranged between the front wheel device and the rear wheel device.

9. The self-propelled surface cleaning machine in accordance with claim 1, wherein in forward travel, applying cleaning liquid to the floor/ground is behind the front wheel device and in front of the rear wheel device.

10. The self-propelled surface cleaning machine in accordance with claim 1, wherein one or more scrubbing elements are provided.

11. The self-propelled surface cleaning machine in accordance with claim 1, wherein said self-propelled surface cleaning machine is configured as a scrubbing machine.

12. The self-propelled surface cleaning machine in accordance with claim 1, wherein said self-propelled surface cleaning machine is attendant-controlled.

13. A self-propelled surface cleaning machine, comprising:

- a front wheel device;
 - a steering device associated with the front wheel device;
 - a steering angle sensor device by which a steering angle at the front wheel device is detectable;
 - a rear wheel device having at least one left rear wheel and at least one right rear wheel;
 - a first electromotive drive device associated with the at least one left rear wheel;
 - a second electromotive drive device associated with the at least one right rear wheel; and
 - a control device operatively connected for signal communication with the steering angle sensor device, the first electromotive drive device and the second electromotive drive device,
- wherein each of the first electromotive drive device and the second electromotive drive device are controllable individually depending on signals from the steering angle sensor device.

14. The self-propelled surface cleaning machine in accordance with claim 13, wherein the cleaning machine is a sweeping machine.

15. A method for operating a self-propelled surface cleaning machine, said cleaning machine having a steered front wheel device and a driven rear wheel device; comprising:

- applying a cleaning liquid to a floor/ground to be cleaned, with an application area being located between the front wheel device and the rear wheel device; and
- controlling individually a first drive device associated with a left rear wheel and a second drive device associated with a right rear wheel, depending on a steering angle at the front wheel device.

16. The method in accordance with claim 15, wherein the rear wheel device is electromotively driven, with an electronic differential device being used for the first drive device and the second drive device.

17. The method in accordance with claim 15, wherein the first drive device and the second drive device are controlled in respect of rotational speed and direction of rotation.

18. The method in accordance with claim 17, wherein a maximum speed is predetermined, said maximum speed depending on the steering angle.

19. A method for operating a self-propelled surface cleaning machine, said cleaning machine having a steered front wheel device and a driven rear wheel device; comprising: controlling individually a first drive device associated with a left rear wheel and a second drive device associated with a right rear wheel, depending on a steering angle at the front wheel device.

20. The method in accordance with claim 19, wherein the cleaning machine is a sweeping machine.

* * * * *