

(19)



Europäisches Patentamt
European Patent Office
Office européen des brevets



(11)

EP 0 506 851 B1

(12)

EUROPEAN PATENT SPECIFICATION

(45) Date of publication and mention
of the grant of the patent:

15.05.1996 Bulletin 1996/20

(21) Application number: **91902495.0**

(22) Date of filing: **11.12.1990**

(51) Int Cl.⁶: **E01C 19/52**

(86) International application number:
PCT/US90/07261

(87) International publication number:
WO 91/09175 (27.06.1991 Gazette 1991/14)

(54) **HOLDING DEVICE FOR PAVING BLOCKS**

HALTEVORRICHTUNG FÜR PFLASTERSTEINE

SYSTEME DE MAINTIEN DE PAVES

(84) Designated Contracting States:
AT BE CH DE DK ES FR GB GR IT LI LU NL SE

(30) Priority: **12.12.1989 US 448960**

(43) Date of publication of application:
07.10.1992 Bulletin 1992/41

(73) Proprietor: **SNAP EDGE CORPORATION**
Chicago, Illinois 60639 (US)

(72) Inventor: **Strobl, Frederick, P., Jr.**
Cary, IL 60013 (US)

(74) Representative: **König, Werner, Dipl.-Ing.**
Habsburgerallee 23-25
D-52064 Aachen (DE)

(56) References cited:

DE-A- 3 600 738	US-A- 1 979 979
US-A- 3 676 952	US-A- 4 824 068
US-A- 4 831 776	US-A- 4 846 437
US-A- 4 863 307	

EP 0 506 851 B1

Note: Within nine months from the publication of the mention of the grant of the European patent, any person may give notice to the European Patent Office of opposition to the European patent granted. Notice of opposition shall be filed in a written reasoned statement. It shall not be deemed to have been filed until the opposition fee has been paid. (Art. 99(1) European Patent Convention).

Description

The invention relates to a device for holding paving materials in place comprising:

an elongated vertical plate having a contact side disposed for facing and contacting the paving material, a lower edge, and a support side disposed to face away from the paving material when the device is installed and support means for supporting the vertical plate and including a rearwardly extending, ground contacting footing structure.

Paving blocks are commonly used in landscaping to achieve both a decorative and a utilitarian function.

However, the natural freezing and thawing cycle of the ground upon which blocks are laid, as well as vehicular and pedestrian traffic, causes movement of the blocks. Such movement destroys both the decorative and the utilitarian function of the blocks. Thus, it becomes well settled in the art that it is highly desirable to hold paving blocks in place.

Various edge support arrangements exist to hold paving blocks in place. The edge support arrangements of the prior art are difficult to construct and bring to bear on the problem.

Typical of the problems caused for an edge support arrangement is the fact that various surfaces are presented by the edge of paving blocks where the holding mechanism is desired. In some cases the edge of the paving blocks can present a straight line to be supported. In other cases, the edge of the paving blocks can present an arcuate (or curved) surface for an edge support arrangement to support. By arcuate is meant a curved or irregularly shaped surface.

US-Patent 4 831 776 describes a landscape edging apparatus comprising an upstanding retainer portion intermediate and integrally formed with a flat flexible mowing strip and a flat flexible anchoring strip. However, when the paving surface is arcuate, it is difficult to adjust the holding mechanism to the appropriate shape. For such shapes different elements corresponding to such shapes have to be used.

It is highly desirable to hold the paving blocks in position with one type of device, which can be easily modified at the job site. If this can be accomplished, it is easier to provide the necessary edge supporting material.

US-Patent 4 863 307 describes a landscaping support apparatus comprising a vertical strip restraining means, a base extension strip rectangular to the said vertical strip and a force converting means in the form of a closed hollow profile interconnecting said strips.

This known apparatus requires only one type of device, but it has the disadvantage of using a hollow profile. Moreover it is difficult with this apparatus to achieve a continuously convex or concave edge.

Also, the length of the edge support arrangement required can provide a problem. The longer the edges of the paving blocks which require support, the more difficult it is to achieve the desired positioning of the edge

support arrangement. Furthermore, as the paving block area extends, the edge may be arcuate, then straight, and then back to arcuate again in a continuous fashion.

It is highly desirable to have one easily modified unit to provide the required edge support for any edge shape of the paving blocks.

Long units of an edge support arrangement present many difficulties. Firstly only certain lengths of material are permitted to be hauled on highways. Secondly, handling of long units presents difficulties at the job site. Additionally, other transportation problems can exist. For example, the structure cannot be compactly fitted into a truck or transportation means. So the long units provide transportation problems and handling difficulties on the job site.

To provide for joining of units of an edge support arrangement to achieve a desired length to solve the long unit problems presents many other problems. The joint inherently produces a weakness in the device. Functioning of the joining device on the job site also presents a problem. Many different parts are required for the joining. A special effort is required to have all of those parts available. Joint strength is inversely proportional to the ease of joining the units. Having the required joining members available may also present a problem.

Holding the edge support in position is a difficult matter. The strength of the support must be maintained, and the support must be left in position -- even during a freeze/thaw cycle. The freeze thaw cycle can force nails holding the support to come loose. A single unit is desired to achieve that holding force. Structure must be developed to avoid that problem.

Nothing holds a paving block holding device in position better than a good root system. It is important that the root system be able to lock into the holding device. Holding devices known in the prior do not permit this desired root interlocking.

It is the objective of the invention to provide a device of the kind above mentioned which is able to minimize movement of the paving materials and which is a single unit system. Further the device should be easy to construct, having an easily adjustable length and being easily handled and modified at the job site.

According to the invention this objective is met in that the footing structure comprises a plurality of elongated, longitudinally spaced belts, each belt having a proximal end secured to the lower edge of the vertical plate and a distal end spaced rearwardly away from said plate and in that an elongated capping member is secured to the distal ends of at least two of said belts to present an opening surrounded by said vertical plate, said belts and said capping member.

The invention can be realized advantageously in that said capping member is severable between said distal ends to free the vertical plate for flexure about a vertical axis. In this way the device is capable of holding straight, arcuate or irregularly shaped edges of paving materials.

The invention can also be realized advantageously in that it includes buttressing structures interconnecting each belt and the vertical plate.

The invention can also be realized advantageously in that each buttressing structure includes a gusset member supported by a centrally located boss, each boss having a nail receiving hole vertically therethrough.

The invention can also be realized advantageously in that it further includes a tab-end at one end thereof and a tab-receiving end oppositely disposed from the tab-end with said tab-end including a male member suitable for locking to a female member on said tab-receiving end so that a first holding device may be joined to a second holding device.

The advantages of the invention will become apparent from the following description of a preferred embodiment of the invention.

Figure 1 is a rear perspective view of the holding device 100 for paving blocks (not shown) of this invention.

Figure 2 is a front elevation view of the holding device for paving blocks of this invention.

Figure 3 is a top plan view of the holding device for paving blocks of this invention.

Figure 4 is a rear elevation view of the holding device for paving blocks of this invention.

Figure 5 is a bottom view of the holding device for paving blocks of this invention.

Figure 6 is a tab end plan view of the holding device for paving blocks of this invention.

Figure 7 is a partial cross-sectional view of the holding device for paving blocks taken along section line 7-7 in Figure 1 to show nail 200 of this invention.

Figure 8 is a top plan view of the holding device for paving blocks of this invention showing a convex arc.

Figure 9 is a top plan view of the holding device for paving blocks of this invention showing a concave arc.

Figure 10 is a partial section of the holding device in a stacked arrangement.

Figure 11 is a tab-receiving end perspective view of the holding device for paving blocks of this invention.

Figure 12 is a tab protruding end perspective view of the holding device for paving blocks of this invention.

Figure 13 is a partial cross-sectional side view of the holding device for paving blocks of this invention showing the tab-receiving end and tab protruding end joined together.

Figure 14 is a perspective view of the nail 200 for use with the holding device for paving blocks of this invention.

Figure 15 is an exploded view of the snap mechanism 150 for use with the holding device for paving blocks of this invention.

Throughout the figures of the drawings where the same part appears in more than one figure of the drawing, the same number is applied thereto.

The holding device for paving blocks of this invention includes a vertical plate for contacting the paving

blocks and various supporting points for the vertical plate. At pre-selected points along the vertical plate are belts of material perpendicular thereto. Buttressing the belts of material in the vertical plate are gusset members supported by a boss member. The boss member provides for driving a nail into the ground and through the support member in order to assist in positioning the holding device for paving blocks until a root system can develop to more solidly position the holding device.

It is difficult to hold the nail in the holding device due to the heaving and pitching caused at the frost line (freezing and refreezing of the ground). The frost line problem is avoided by the barbs on the nail which passes through the boss member as the nail is driven there-through and locked within the edge support. In this manner, the holding device is positioned until a root system is developed to secure the positioning. The nail is most suitable for use in frost free ground, and can be used to position the holding device until the root system develops.

Capping the edge support or the individual strips is a long member strip running the length of the vertical plate. In this fashion, between the gusset members and the edge support are provided openings for grass and other vegetation to grow therethrough and support the positioning of the edge support strip.

On a tab end of the holding device for paving blocks is a male member suitable for locking one holding device to another. The tab end cooperates in locking one holding device to another with the female member on the other end of the holding device. The holding device has integral fastening devices built therein. A highly desired strength support is achieved. In this fashion, varying lengths of paving blocks can be supported by a long device formed by using a number of holding devices.

If it is desired to form a bendable member, the strips across the rear edge may be cut and, if required, a portion thereof removed. Merely cutting is usually sufficient. It is also possible to have a breakable point in the long member strip. In this fashion, the bending can be achieved in a concave or convex fashion to go around curves formed by paving blocks.

It is also possible to put in boss members for stacking of the holding devices. In this fashion, transportation of a plurality of holding devices becomes simplified.

In order to make the holding device for paving blocks of this invention any suitable process may be used. However, the unique shape of this device permits the use of injection molding of a plastic or synthetic resin to provide a strong device, which may be used in an efficient manner. The tab set up and the molding permits highly efficient production and reproducibility of the holding device. In this fashion, great advantages are obtained. Stacking bosses can be placed at the mold knockout points and achieve the desired efficient combination and effective use of this holding device.

Referring now to Figure 1, Figure 2 and Figure 3 the holding device for paving blocks includes a vertical plate

120. The vertical plate 120 is a long flat piece of material having a contact side 122 for contacting the paving blocks and a support side 124 for receiving a support member 140 having a plurality of parts at various points along the vertical plate 120. At pre-selected points along the vertical plate 120 are belts 142 forming part of support member 140. Each belt 142 is substantially perpendicular to the vertical plate 120 at a bottom edge 126 thereof.

Capping each end of the holding device for paving blocks is a trapezoid cap 138. The trapezoid cap 138 supports the vertical plate 120 and support member 140 in their relationship.

Buttressing each belt 142 between each trapezoid cap 138 is a gusset member 160 supported by a centrally located boss member 162. This boss member 162 is substantially parallel to the vertical plate 120, and provides for driving a nail 200 (shown in Figure 14) into the ground to hold the holding device 100 in position. The nail 200 passes through boss member 162 because boss member 162 is a hollow cylinder.

A first slab 164 is between the boss member 162 and vertical plate 120 as an integral support therefore. A second slab 166 is on a side of boss member 162 opposite first slab 164 and also supports the boss member 162. Preferably for ease of molding, first slab 164 and second slab 166 are of trapezoidal shape.

Capping the belts 142 is a capping strip 144. Second slab 166 is adjacent to the capping strip 144. Both the belts 142 and the capping strip 144 are flat material. The longitudinal axis of the capping strip 144 is substantially perpendicular to the longitudinal axis of each belt 142. In this manner a common plane 144 is defined by belts 142 and capping strip 144. This common plane is substantially perpendicular to plane defined by vertical plate 120. In this fashion, belts 142, vertical plate 120, and capping strip 144 combine to provide a plurality of openings 148 of generally rectangular shape for grass or other vegetation to grow therethrough and support the positioning of the holding device for paving blocks.

Referring now to Figure 3, Figure 4, Figure 6, Figure 11, Figure 12 and Figure 13, on a tab end 128 of the holding device for paving blocks is a male member 130 suitable for locking to other members. The tab end 128 cooperates in locking one holding device 100 to another with the female member 132 on the receiving end 134, to provide highly desired strength for the joint. The trapezoid cap 138 is located at each of tab end 128 and receiving end 134. In this situation, any suitable length can be formed by using a number of holding devices 100.

Figure 7 and Figure 14 depict a special nail 200 for use herewith. It is difficult to hold a nail in the holding device 100. The frost line problem is avoided by the barbs 202 on the nail 200 which goes through the boss member 162 at boss aperture 164 and locks within the boss member 162.

A bendable version of the holding device for paving blocks can be formed as shown in Figure 8 and Figure

9 by cutting and separating capping strip 144. Also removing a section of the capping strip 144 between a pair of gusset members 160 is possible but not required. Mere separation of the capping strip 144 can achieve the bendable nature of vertical plate 120, and hence the holding device for paving blocks as desired.

By considering Figure 15 with Figure 1, the capping strip 144 may additionally have a snap mechanism 150 having a male snap 152 and female snap 154 across the capping strip 144. Capping strip 144 may then be separated or rejoined as desired between a pair of gusset members 160. With the separation of the capping strip 144, the bending of vertical plate can be achieved in a concave or convex fashion to go around curves formed by paving blocks -- without cutting.

It is also possible as shown in Figure 10 to put in stacking boss members 220 for stacking of the holding devices 100. Stacking boss members 220 may include a male boss member 222 on capping strip 144 and the female boss member 224 on vertical plate 120 at top edge 128 thereof. In this fashion, transportation of a plurality of holding devices 100 becomes simplified.

This application -- taken as a whole with the specification, claims, and drawings -- provides sufficient information for a person having ordinary skill in the art to practice the invention disclosed and claimed herein. Any measures necessary to practice this invention are well within the skill of a person having ordinary skill in this art after that person has made a careful study of this disclosure.

Because of this disclosure and solely because of this disclosure, modification of this method and apparatus can become clear to a person having ordinary skill in this particular art. Such modifications are clearly covered by this disclosure.

Claims

1. A device for holding paving materials in place comprising:

an elongated vertical plate (120) having a contact side (122) disposed for facing and contacting the paving material, a lower edge, and a support side (124) disposed to face away from the paving material when the device is installed and support means for supporting the vertical plate (120) and including a rearwardly extending, ground contacting footing structure, characterized

in that the footing structure comprises a plurality of elongated, longitudinally spaced belts (142), each belt (142) having a proximal end secured to the lower edge of the vertical plate (120) and a distal end spaced rearwardly away from said plate and

in that an elongated capping member (144) is

secured to the distal ends of at least two of said belts (142) to present an opening surrounded by said vertical plate (120), said belts (142) and said capping member (144).

2. A device according to claim 1, characterized in that said capping member (144) is severable between said distal ends to free the vertical plate (120) for flexure about a vertical axis.
3. A device according to claim 1 or 2, characterized in that it includes buttressing structures interconnecting each belt (142) and the vertical plate (120).
4. A device according to claim 3, characterized in that each buttressing structure includes a gusset member (160) supported by a centrally located boss (162), each boss having a nail receiving hole vertically therethrough.
5. A device according to one of the preceding claims, characterized in that it further includes a tab-end at one end thereof and a tab-receiving end oppositely disposed from the tab-end with said tab-end including a male member suitable for locking to a female member on said tab-receiving end so that a first holding device may be joined to a second holding device.

Patentansprüche

1. Eine Vorrichtung zur Fixierung von Pflastersteinen an Ort und Stelle, bestehend aus:
einer in Längsrichtung verlaufender, vertikal ausgerichteter Platte (120) mit einer Kontaktseite (122) für die stirnseitige Ansetzung und Berührung durch das Pflastermaterial, mit einer unteren Abschlußkante und einer Stützseite (124), die so angeordnet ist, daß sie von dem Pflastermaterial weg gewendet ist, wenn die Vorrichtung installiert wird, und Stützelemente für die Abstützung der senkrechten Platte (120), ergänzt durch eine sich nach hinten erstreckende und den Boden berührende Aufsetzkonstruktion, dadurch gekennzeichnet, daß die Aufsetzkonstruktion eine Vielzahl von verlängerten, in Längsrichtung in Abständen zueinander angeordneten Ankern (142) umfaßt, wobei jeder Anker (142) ein proximales Ende besitzt, das an der unteren Kante der senkrechten Platte (120) befestigt ist, zusammen mit einem distalen Ende, das nach rückwärts in einem Abstand zu der besagten Platte entfernt angeordnet ist, ferner dadurch gekennzeichnet, daß ein verlängertes Abschlußelement (144) an den distalen Enden von mindestens zwei der besagten Anker (142) befestigt ist, um eine Öffnung zu bilden, die von der besagten senkrechten Platte (120), den besagten Ankern

(142) und dem besagten Abschlußelement (144) umgeben wird.

2. Eine Vorrichtung gemäß Anspruch 1, dadurch gekennzeichnet, daß das besagte Abschlußelement (144) zwischen den besagten distalen Enden getrennt werden kann, um die vertikale Platte (120) freizusetzen, damit sie sich um eine vertikale Achse biegen kann.
3. Eine Vorrichtung gemäß Anspruch 1 oder 2, dadurch gekennzeichnet, daß sie Stütz- oder Strebevorrichtungen besitzt, die jeden Anker (142) und die senkrechte Platte (120) miteinander verbinden.
4. Eine Vorrichtung gemäß Anspruch 3, dadurch gekennzeichnet, daß jede Stütz- oder Strebekonstruktion ein eingesetztes Keilstück (160) umfaßt, das durch einen zentral angeordneten Hohlzylinder (162) gestützt wird, wobei jeder dieser Hohlzylinder eine Öffnung besitzt, durch die vertikal ein Nagel eingeschlagen werden kann.
5. Eine Vorrichtung gemäß einer der vorausgegangenen Ansprüche, dadurch gekennzeichnet, daß sie ferner an einem Ende ein sogenanntes Lappenelement besitzt und entgegengesetzt hierzu ein Lappenaufnahmeende, wobei das besagte Lappenelement ein äußeres Element besitzt, das geeignet ist, mit einem inneren Element auf dem besagten Lappenaufnahmeende verriegelt zu werden, so daß eine erste Haltevorrichtung mit einer zweiten Haltevorrichtung verbunden werden kann.

Revendications

1. L'invention concerne un système de maintien de pavés composé de: une plaque verticale allongée (120) présentant une face de contact (122) disposée de manière à se trouver face aux pavés et à entrer en contact avec eux, un bord inférieur, et une face de support (124) disposée de manière opposée aux pavés lorsque le système est installé, ainsi qu'un d'un dispositif de support de la plaque verticale (120) comportant une structure d'assise de pied en contact avec le sol et s'étendant vers l'arrière,

caractérisée en ce que la structure d'assise de pied comporte toute une série d'armatures allongées (142) espacées longitudinalement, chaque armature (142) présentant une extrémité proximale fixée au bord inférieur de la plaque verticale (120), et une extrémité distale espacée vers l'arrière par rapport à ladite plaque, et en ce qu'une pièce de recouvrement allongée

(144) est fixée aux extrémités distales d'au moins deux desdites armatures (142) afin de présenter une ouverture entourée de ladite plaque verticale (120), lesdites armatures (142) et ladite pièce de recouvrement (144).

5

2. Un système selon la revendication 1, caractérisé en ce que ladite pièce de recouvrement (144) est séparable entre lesdites extrémités distales afin de permettre une flexion sur un plan vertical de la plaque verticale (120). 10
3. Un système selon la revendication 1 ou 2, caractérisé en ce qu'il comporte des contreforts raccordant chaque armature (142) à la plaque verticale (120). 15
4. Un système selon la revendication 3, caractérisé en ce que chaque contrefort comporte une pièce gousset (160) supportée par une protubérance centrale (162), et dont chaque protubérance comporte un trou de réception de clou percé verticalement à travers celle-ci. 20
5. Un système selon l'une des revendications ci-dessus, caractérisé en ce qu'il comporte en outre une patte à l'une de ses extrémités et une fiche de réception de cette patte à son extrémité opposée, où la patte est la partie mâle et la fiche de réception la partie femelle dans laquelle elle s'enclenche de sorte qu'un premier dispositif de support puisse être relié à un second dispositif de support. 25
30

35

40

45

50

55

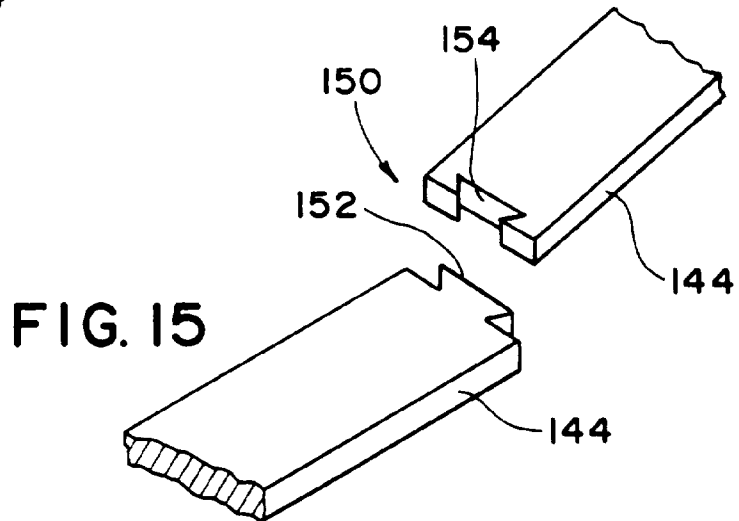
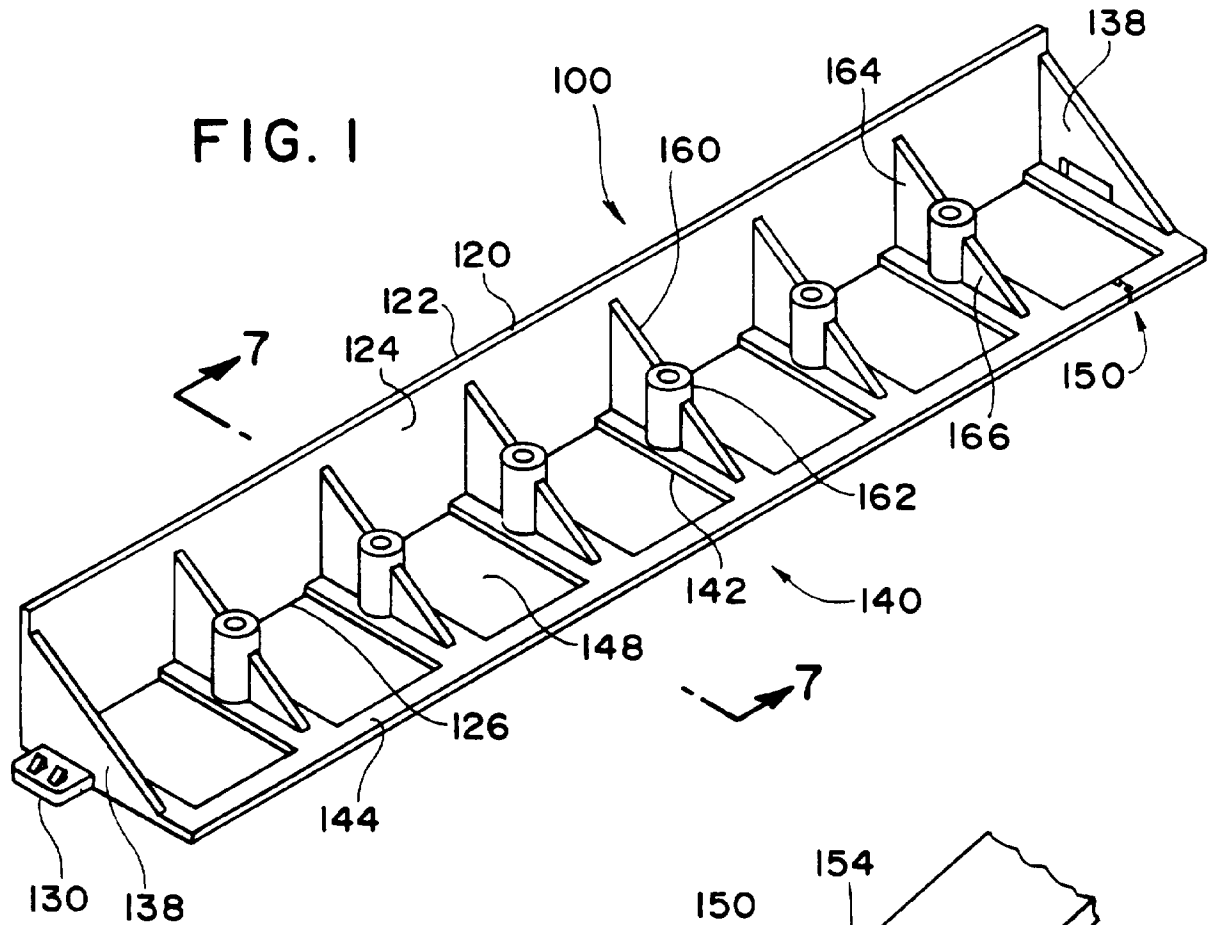

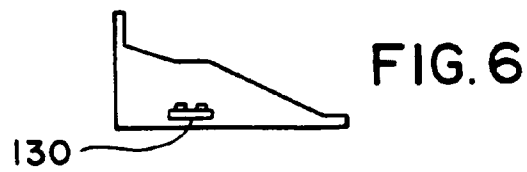
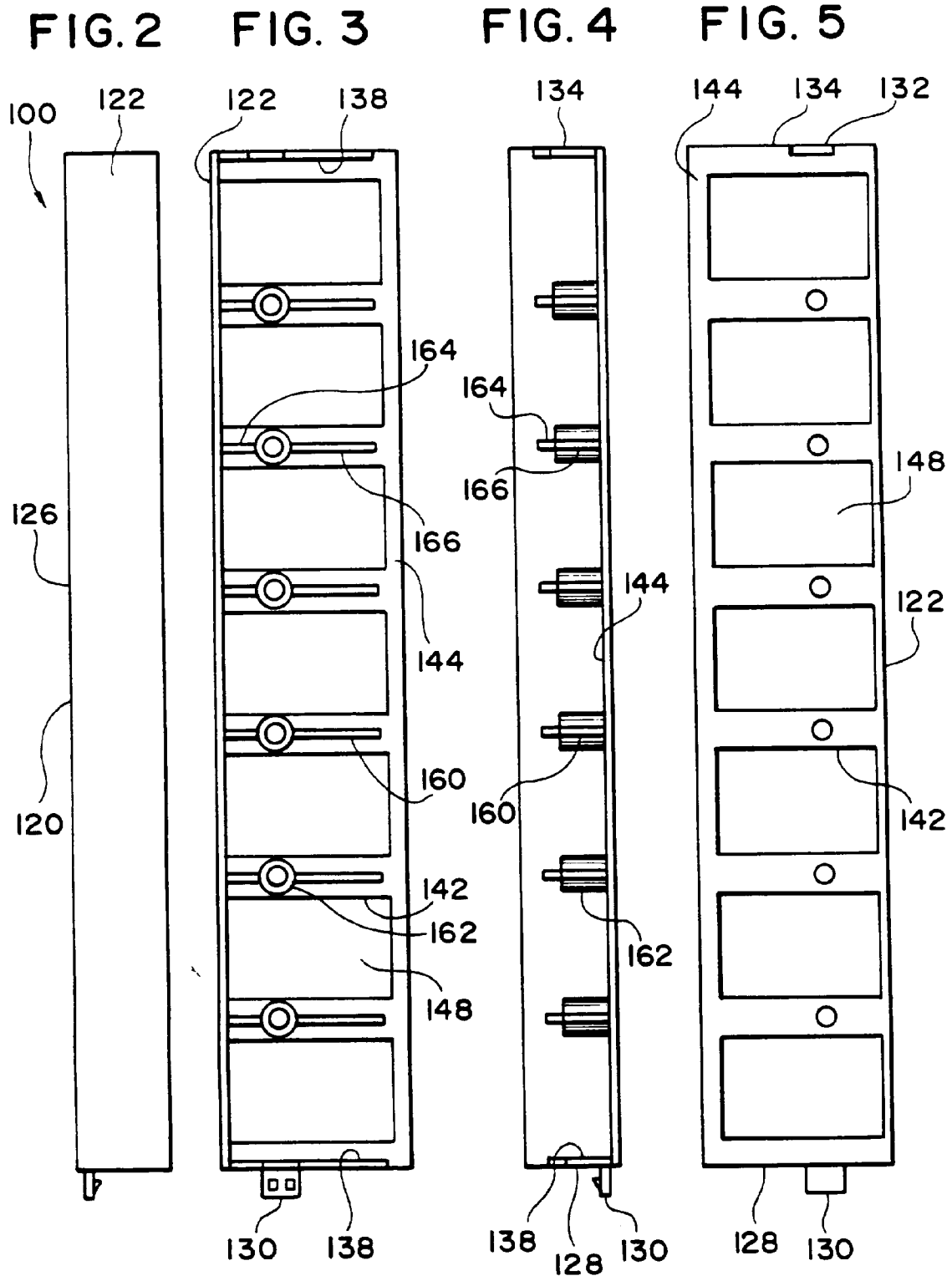

FIG. 8

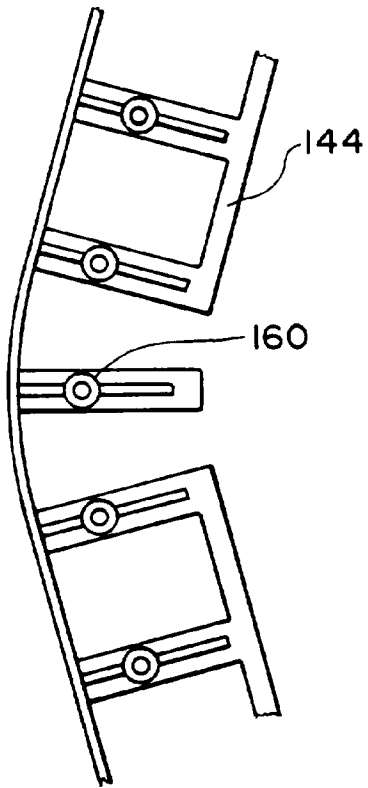

FIG. 9

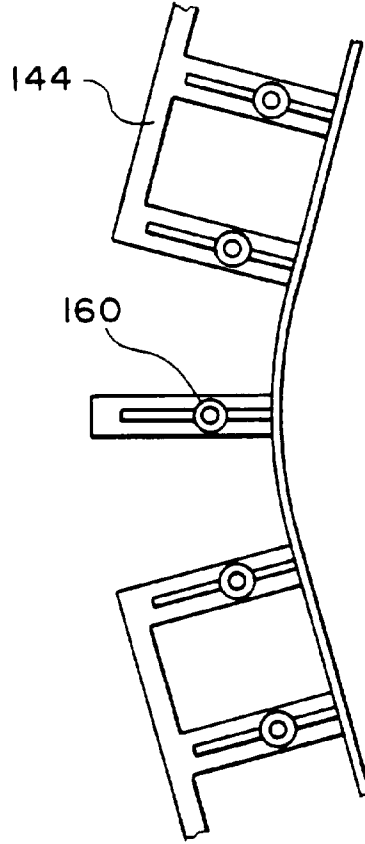

FIG. 14

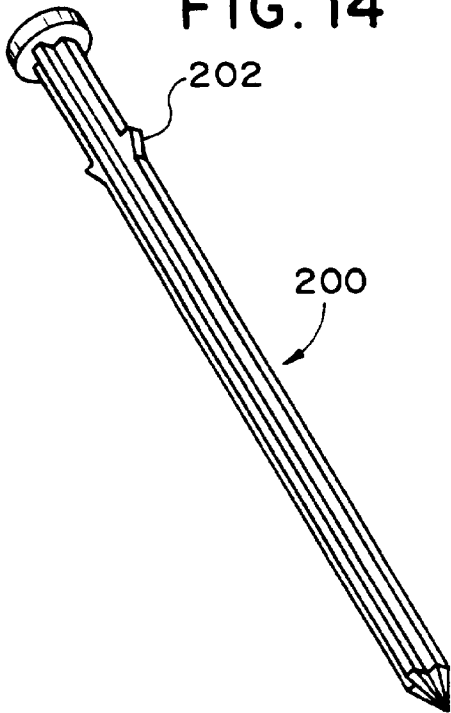

FIG. 7

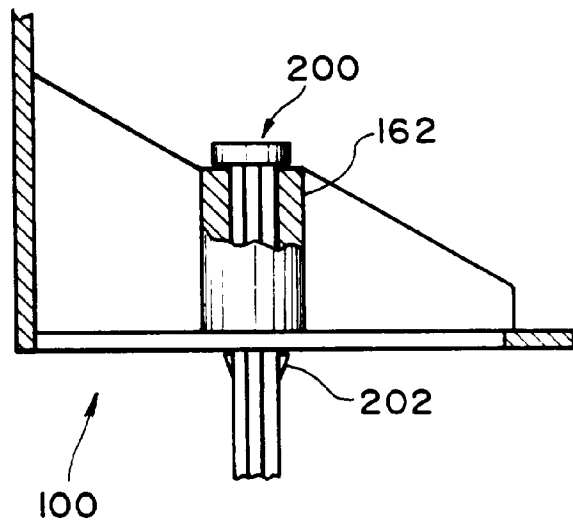

FIG. 10

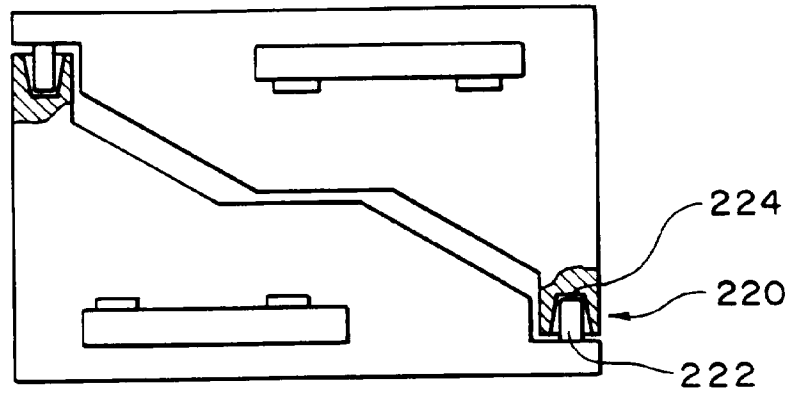

FIG. 11

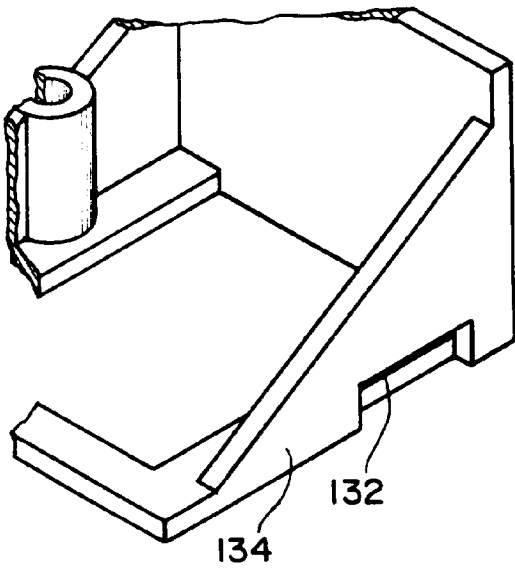

FIG. 12

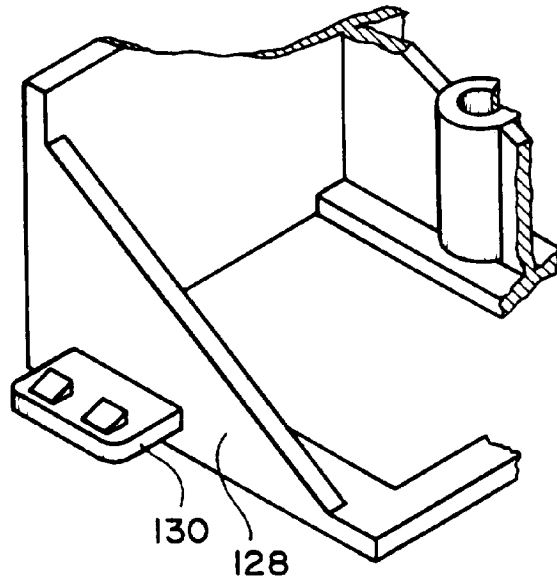

FIG. 13

