

J. A. TOLIVER.
 REVERSING MECHANISM FOR STEAM ENGINES.
 APPLICATION FILED OCT. 14, 1909.

991,673.

Patented May 9, 1911.

2 SHEETS—SHEET 1.

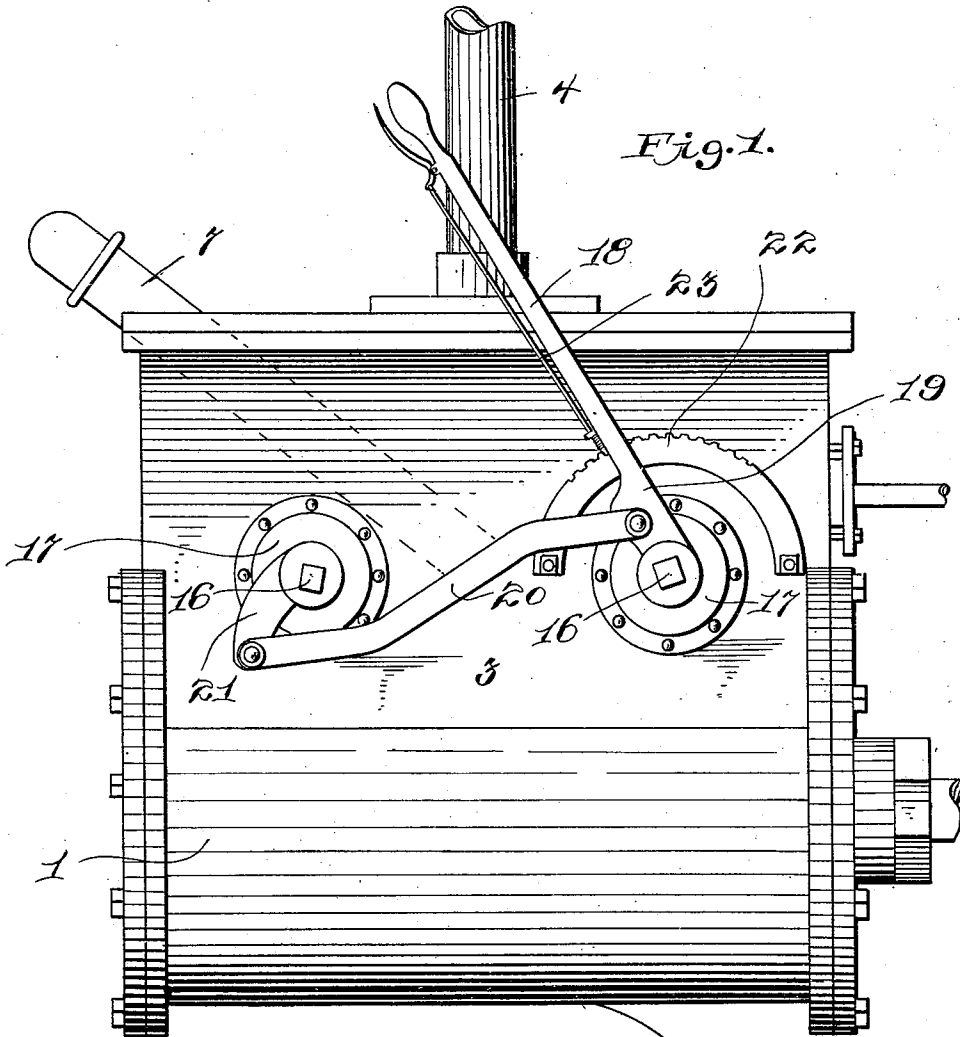

Fig. 1.

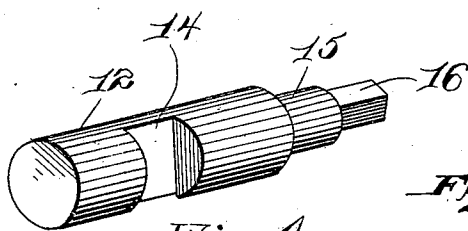

Fig. 4.

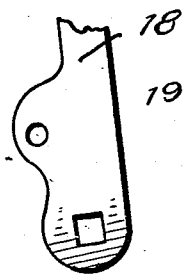

Fig. 5.

Witnesses
J. Ward
H. J. ...

Inventor
James A. Toliver:
By E. C. ...
 Attorney.

J. A. TOLIVER.
 REVERSING MECHANISM FOR STEAM ENGINES.
 APPLICATION FILED OCT. 14, 1909.

991,673.

Patented May 9, 1911.
 2 SHEETS—SHEET 2.

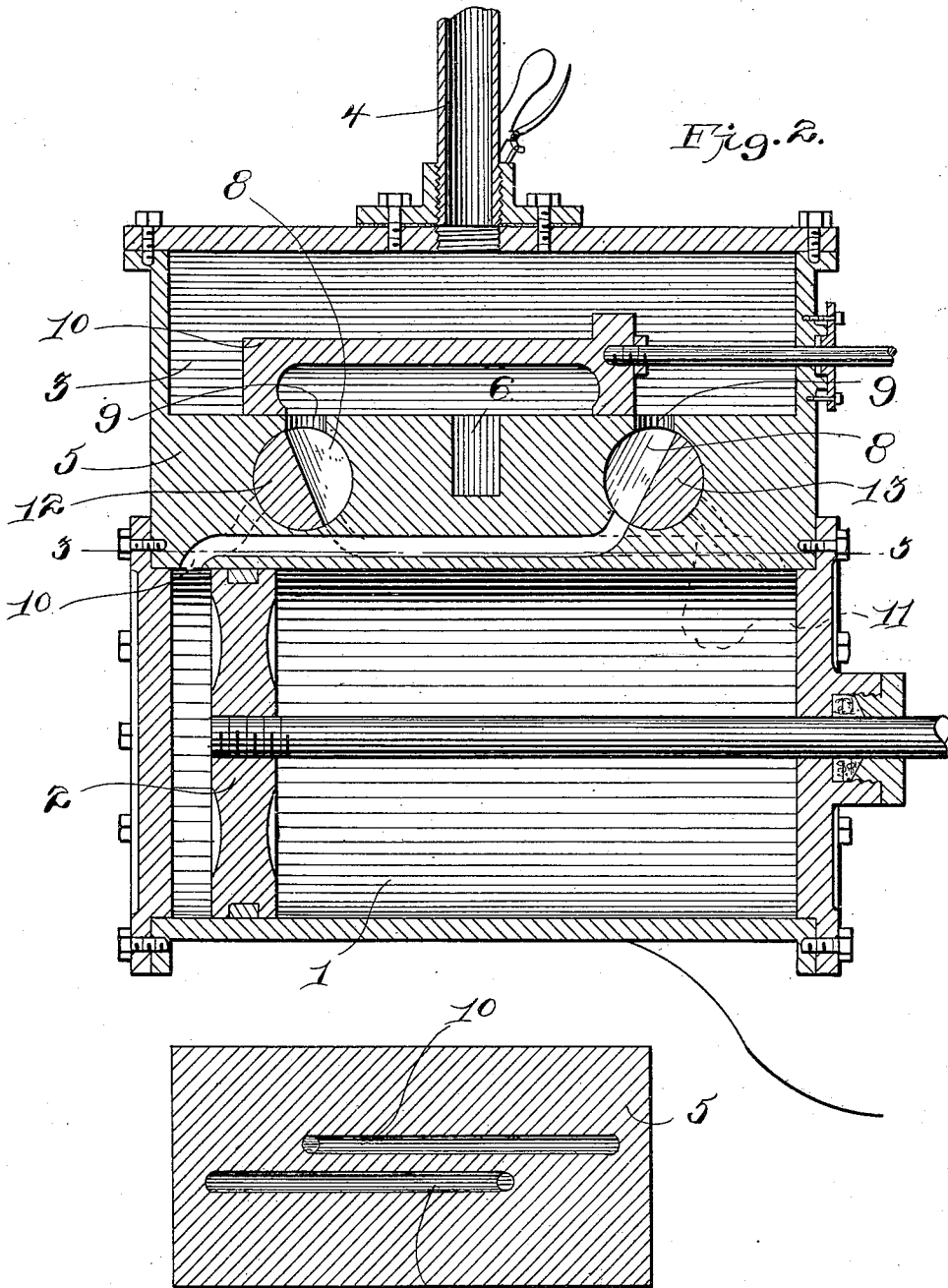

Witnesses
J. W. Lee
H. J. ...

Inventor
James A. Toliver
 By *E. E. ...*
 Attorney.

UNITED STATES PATENT OFFICE.

JAMES ALVA TOLIVER, OF OKLAHOMA, OKLAHOMA.

REVERSING MECHANISM FOR STEAM-ENGINES.

991,673.

Specification of Letters Patent.

Patented May 9, 1911.

Application filed October 14, 1909. Serial No. 522,568.

To all whom it may concern:

Be it known that I, JAMES ALVA TOLIVER, a citizen of the United States, residing at Oklahoma city, in the county of Oklahoma and State of Oklahoma, have invented certain new and useful Improvements in Reversing Mechanism for Steam-Engines, of which the following is a specification, reference being had therein to the accompanying drawing.

My invention relates to reversing mechanism for steam engines and it consists in the construction and arrangement of parts, as will be hereinafter described and particularly pointed out in the claim.

In the accompanying drawings; Figure 1 is a view in side elevation of the steam chest and cylinder, showing the improved valve operating mechanism applied thereto. Fig. 2 is a central vertical sectional view thereof. Fig. 3 is a horizontal sectional view taken on the line 3—3, Fig. 2. Fig. 4 is a detail perspective view of one of the rotating valves.

Referring to said drawings by numerals, 1 designates an engine cylinder in which the usual piston 2 is mounted for reciprocation, and 3 designates an ordinary steam chest which is bolted or otherwise rigidly secured to the upper surface of said cylinder. The said steam chest 3 is provided with a steam supply pipe 4 and with a thickened base 5 which is provided with a central exhaust port 6 which communicates with exhaust pipe 7, and on each side of said port 6, the cylinder base 5 is provided with transverse annular valve chambers 8, each having a port 9 which communicates with the interior of the steam chest 3. A sliding valve 10 is mounted for reciprocation within the steam chest and is adapted to alternately open and close the ports 9 in the manner well understood. Each valve chamber is in communication with the steam channels 10^a—11 which deliver steam to, and exhaust from, the opposite ends of the cylinder 1 in a manner well understood.

As will be understood from the foregoing, there are two valve chambers cored through the base 5 of the steam chest 3, one end of each chamber opening through the side of the steam chest. A rotating valve is provided for each chamber, said valves being of duplicate construction and designated by the numerals 12—13. Each valve is provided with a transverse cavity 14 in its body

portion and one end is provided with a reduced shoulder 15, which terminates in a squared extension 16. These valves are inserted in their respective chambers 8 with their shouldered end projecting beyond one side of the chest 3 and are rotatably held in said chambers by the cap bearings 17 so that the squared end 16 of each projects slightly beyond the side of said chest. A hand lever 18 has its enlarged end 19 fastened over the squared end 16 of the valve 12, said lever having one end of a link 20 pivotally connected to its enlarged end 19, the other end of said link being pivotally connected to a downwardly extending curved crank arm 21 fast on the projected squared end 16 of the valve 13. A semicircular rack 22 is arranged above and partially surrounds the cap bearings 17 of the valve 12, the teeth of said rack being adapted to be engaged by the spring pressed pawl 23, carried by the lever 18.

The link 21 is formed of a bar which has an inclined intervening portion and portions extending at an angle to said intervening portion. By means of this construction with the ends pivotally connected to the lower end of the downwardly extending curved lever arm 21 and to the enlarged portion 19 of the lever 18 eccentrically to the pivotal connection of the end of the lever 18, the throw of the operating connections will be advantageously increased.

As will be seen by reference to Fig. 2, the piston 2 is in position to be forced rearwardly by the live steam entering the cylinder through the port 11, the exhaust from the cylinder to be forced through port 10 to the exhaust port 6.

To reverse the engine it will be obvious that it is necessary to simultaneously shift the position of the rotating valves 12—13, which shifting of the valves is obtained by rocking the lever 18 which has the described connection with the valve 12 and the link connection 20 with the valve 13 so that when said lever 23 is rocked from left position shown in Fig. 1 to the right the valves 12—13 will be simultaneously rotated so that the live steam will be admitted to the right hand end of cylinder 1, thereby reversing the stroke of the piston as will be understood.

From the foregoing it will be seen that the described manner of connecting the valves 12—13 provides a simple and effective means

whereby the engine may be reversed by the engineer or other attendant without the necessity of shifting the position of the usual eccentrics.

5 What I claim as my invention is:—

In a reversing mechanism for steam engines, the combination of a pair of rotary steam valves each provided with lateral cut-away portions forming passages, steam cylinder ports leading to the cylinder ends co-
10 operating with said passages, with means for simultaneously operating said valves in opposite directions, consisting of stems on

said valves, an upwardly turned hand lever attached to the stem of one valve and having an off-set portion provided with an eye, a downwardly turned lever attached to the stem of the other valve, and a link connecting said eye with the outward end of said second lever, substantially as described. 15 20

In testimony whereof I hereunto affix my signature in presence of two witnesses.

JAMES ALVA TOLIVER.

Witnesses:

CHARLEY J. BILLEN,
J. T. HARRALL.

Copies of this patent may be obtained for five cents each, by addressing the "Commissioner of Patents, Washington, D. C."
