

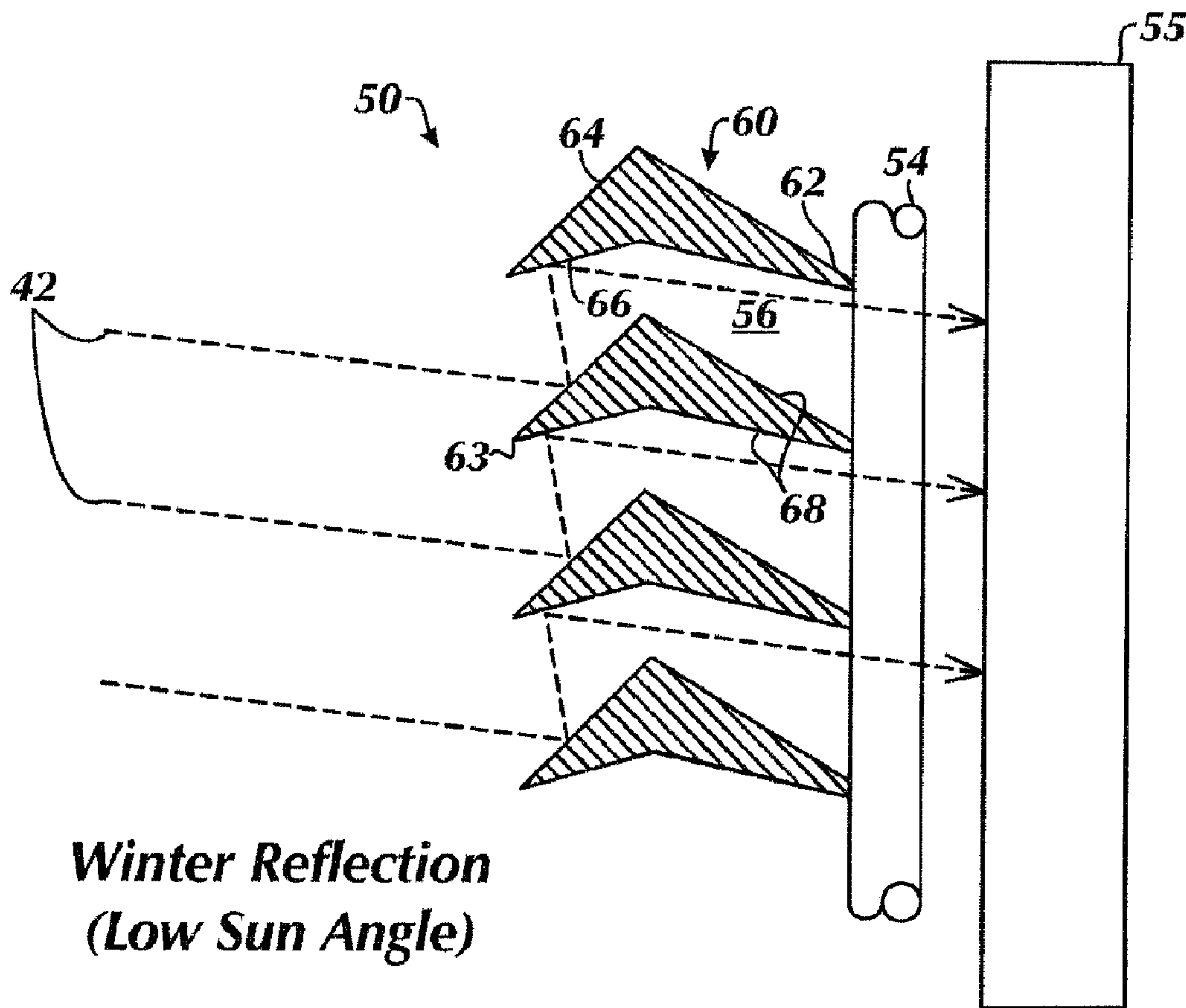

(22) Date de dépôt/Filing Date: 2009/08/11
(41) Mise à la disp. pub./Open to Public Insp.: 2010/04/27
(45) Date de délivrance/Issue Date: 2014/12/23
(30) Priorité/Priority: 2008/10/27 (US12/258,796)

(51) Cl.Int./Int.Cl. *F24J 2/46* (2006.01)
(72) Inventeurs/Inventors:
MAXSON, RICHARD C., US;
EKHOLM, MICHAEL, US
(73) Propriétaire/Owner:
JOHNSON SCREENS, INC., US
(74) Agent: GOODWIN MCKAY

(54) Titre : PANNEAUX SOLAIRES PASSIFS EN TREILLIS POUR BATIMENTS
(54) Title: PASSIVE SOLAR WIRE SCREENS FOR BUILDINGS



(57) Abrégé/Abstract:

Passive solar wire screens mount vertically on an edifice. The screens have rods vertically arranged parallel to one another and have wires horizontally arranged parallel to one another. The wires attach to the rods and have first surfaces facing away from the

(57) **Abrégé(suite)/Abstract(continued):**

edifice in an upward direction from vertical. The wires also have second surfaces facing toward the edifice in a downward direction from vertical. When the sun has a summer elevation on the horizon, the first surfaces passively reflect solar energy incident thereto away from the wire screens. When the sun has a winter elevation on the horizon, however, the first surfaces passively reflect solar energy incident thereto toward the second surfaces, which in turn passively reflect the solar energy toward the edifice. A concave surface on the wires can also reflect thermal energy back to the edifice.

ABSTRACT

Passive solar wire screens mount vertically on an edifice. The screens have rods vertically arranged parallel to one another and have wires
5 horizontally arranged parallel to one another. The wires attach to the rods and have first surfaces facing away from the edifice in an upward direction from vertical. The wires also have second surfaces facing toward the edifice in a downward direction from vertical. When the sun has a summer elevation on the horizon, the first surfaces passively reflect solar energy incident thereto away
10 from the wire screens. When the sun has a winter elevation on the horizon, however, the first surfaces passively reflect solar energy incident thereto toward the second surfaces, which in turn passively reflect the solar energy toward the edifice. A concave surface on the wires can also reflect thermal energy back to the edifice.

15

TITLE: PASSIVE SOLAR WIRE SCREENS FOR BUILDINGS

FIELD OF THE INVENTION

The invention relates to a passive solar wire screen system which
5 can be mounted vertically on an edifice, building or other structure. More particularly the screen passively reflects solar energy away from the edifice when the sun has a higher summer elevation and reflects solar energy towards the edifice when the sun has a lower winter elevation.

10

BACKGROUND

Wire screens are used for chemical filtration, architectural accents, and other purposes. FIG. 1 shows the typical construction of a prior art wire screen. As shown, the screen has parallel wires 12 attached by welds 16 to parallel rods 14 oriented perpendicularly thereto. The wires 12 can be V-shaped
15 wires, and the rods 14 can be cylindrical, square, etc. Both the wires 12 and rods 14 are typically made of stainless steel, but they can be made of other materials, including aluminum and copper alloys.

In industrial applications, gaps between the screen's wires 12 can filter chemical compositions, solids, etc. In architectural applications, the screens
20 can be used on a building as a decorative feature for frontages, overhangs, column covers, floor gratings, ventilation grids, wall partitions, handrails, etc. For example, the Seven World Trade Center in New York and the Guthrie Theater parking garage in Minneapolis have wire screens that cover the exterior. Typically, the architectural design of such wire screens has focused on the
25 reflectivity and orientation of the wire surfaces to enhance appearance.

SUMMARY

Passive solar wire screens mount vertically on an edifice, building, or other structure. The screens have rods vertically arranged parallel to one
30 another and have wires horizontally arranged parallel to one another and attached to the rods. The wires have first surfaces facing away from the edifice

for non-building applications, such as delivery trucks, rail cars, temporary structures, etc. These wire screens 50 can be constructed as panels and made of any particular dimensions suitable for their own support and reinforcement, and the screens 50 can attach to the building 25 using any conventional
5 technique, such as brackets, frames, and other similar mounting hardware. The wire screens 50 can be designed with standard dimensions and mounting hardware or may be individually configured for a given implementation.

In the northern hemisphere, the wire screens 50 are preferably mounted on one or more south-facing walls of the building 25 (the opposite being
10 the case of a building in the southern hemisphere) so that the wire screens 50 face the orientation of the sun as it travels across the sky. As oriented, the wire screens 50 can reflect solar energy away from the building 25 when the sun has a higher summer elevation 30 on the horizon and can direct solar energy toward the building 25 when the sun has a lower winter elevation 40. In this way, the
15 wire screens 50 act as a seasonally reflective exterior surface of the building 25 that passively reflects solar energy in the summer and passively collects solar energy in the winter to reduce both heating and cooling costs for the building 25.

Front and back sides of portion of a wire screen 50 are shown in FIGS. 3A-3B, respectively. The screen 50 has a plurality of horizontally arranged
20 wires 52 positioned parallel to one another on its front face as shown in FIG. 3A. These wires 52 weld to a plurality of vertically arranged rods 54 positioned on the screen's back face as shown in FIG. 3B. Many of the same techniques for constructing, arranging, and welding wire screens known in the art can also be used for the wires 52 and rods 54 of the disclosed screens 50 so that specific
25 details are not provided herein. The wires 52, however, have an asymmetrical shape to achieve the reflection and collection of solar energy so that fabricating the screen 50 may require particular attention to precision when attaching the wires 52 to the rods 54.

The wire screens 50 mounted to the building 25 are entirely passive
30 and function without moving parts, such as an adjustable louver system, electronic controls, and the like. In this way, the wire screens 50 can operate

passively with the seasonal changes in reflectivity while still functioning as a decorative feature. Lacking a movable louver and control system or the like, the passive wire screens 50 require less cost for installation and operation, although the disclosed screens 50 could be constructed with such moving parts if desired.

5 As noted briefly above, the wires 52 of the screen 50 have an asymmetrical shape that is different than the conventional wires used on prior art wire screens. In particular, FIGS. 4A-4B show details of one embodiment of wires 60 for the disclosed wire screen 50. In the end view shown, the screen 50 mounts adjacent an absorption surface 55, which could be a wall, window, or
10 other part of an edifice, building, or the like. This surface 55 could be painted black to absorb incoming radiation. Alternatively, the surface 55 could be a conventional solar collector placed behind the screen 50 to enhance collection efficiencies.

 As shown, each of the wires 60 has an acute back edge 62, a
15 reflective front face 64, and a reflective under surface 66. The back edge 62 welds to the vertically arranged rods 54 using conventional techniques. As shown, adjacent wires 60 are attached at a separation from one another on the rods 54 so that a curved or bent channel 56 is defined between each adjacent wire 60. The front face 64 extends from a front edge 63 and faces upwards
20 toward the horizon at an angle θ_1 from vertical. The under surface 66 also extends from the front edge 63 but faces downward towards the surface 55 at an angle θ_2 from horizontal. The front faces 64 and surfaces 66 can be polished or coated to enhance their reflectivity.

 The angular orientation θ_1 of the front face 64 can be selected to
25 passively reflect solar energy incident thereto away from the surface 55 in the summer months (when the sun's elevation is high) and to passively reflect the solar energy upwards towards the adjacent wire 60 in the winter months (when the sun's elevation is low on the horizon). Likewise, the angular orientation θ_2 of the under surface 66 can be selected to passively reflect the reflected solar
30 energy incident thereto from the wire 60 below towards the surface 55 in the winter months. In this way, the screens 50 can help maintain the surface 55

cooler in the summer months and can provide heat energy to the surface 55 in the winter.

The front face 64 and surface 66 could be either flat or curved (parabolic) to maximize collection efficiency. In one implementation, the front face 64 can be flat as shown in FIGS. 4A-4B and can be at the acute angle θ_1 of approximately 45-degrees from vertical. The under surface 66 can also be flat as shown and can be at the acute angle θ_2 of about 15-degrees from horizontal. However, the angles, size, and separation of the wires 60 may change depending on the latitude of the building or other structure on which they are used and depending on the orientation of the screen 50 relative to the sun's rays. (The orientations of the sun's rays 32/42 depicted in the drawings are representative and provided for illustrative purposes.)

As shown in FIG. 4A, the wires' front faces 64 of the wires 60 reflect rays 32 from the sun at the higher summer elevation incident thereto away from the screen 50. In this way, the screen 50 functions as a reflector during summer months when the sun's elevation is high on the horizon so that the energy from the sun's rays 32 can be reflected away from the surface 55.

As shown in FIG. 4B, the wires' front faces 64 reflect rays 42 from the sun at the lower winter elevation incident thereto upward toward the angled under surfaces 66 of adjacent wires 60. In turn, the under surfaces 66 reflect the rays back towards the building's surface 55. In this way, the wire screen 50 functions as a collector of the sun's rays 42 during winter months when the sun's elevation is lower on the horizon so that the energy from the sun's rays 42 can be reflected onto the surface 55.

In FIGS. 5A-5B, details of another embodiment of wires 70 for the disclosed wire screen 50 are illustrated in end views. As before, these wires 70 have acute back edges 72 that weld to the rods 54 of the screen 50. In contrast to the previous embodiment, the wires 70 have concave front faces 74 and concave under surfaces 76 that extend from front edges 73. As before, adjacent wires 70 are attached at a separation from one another on the rods 54 so that the curved or bent channel 56 is defined between each adjacent wire 70.

As shown in FIG. 5A, the concave front faces 74 reflect rays 32 from the sun at the high summer elevation incident thereto away from the wires 70 so the wire screen 50 functions as a reflector and keeps the sun's energy away from the surface 55. As shown in FIG. 5B, the concave front faces 74 reflect rays 42 from the sun at the lower winter elevation incident thereto upward toward the concave under surface 76 of adjacent wires 70. In turn, the concave under surfaces 76 reflect the solar rays back towards the building's surface 55 so the wire screen 50 functions as a collector.

As noted previously, adjacent wires 60/70 are attached at a separation from one another on the rods 54 so that the curved or bent channel 56 defined between each adjacent wire 60/70 allows the reflected rays 42 to reach the surface 55. Each wire 60/70 has surfaces 68/78 above and below the back edge 62/72 that are oriented to create this channel 56. These surfaces 68/78 may also be capable of reflecting at least some of the thermal energy emanating from the surface 55 back to the surface 55.

In FIG. 6, details of another arrangement of wires 80 for the disclosed wire screen 50 is illustrated in an end view. As before, these wires 80 have back edges 82 that weld to the rods 54 of the screen 50. In addition, the wires 80 have front faces 84 and under surfaces 86 that extend from front edges 83. These faces 84 and surface 86 can be curved as shown or can be angled as discussed previously. As before, the adjacent wires 80 are attached at a separation from one another on the rods 54 so that a channel 56 is defined between each adjacent wire 80.

When the sun is at the high summer elevation, the front faces 84 can reflect summer rays 32 incident thereto away from the wires 80 so the wire screen 50 functions as a reflector and keeps the sun's energy away from the surface 55. When the sun is at the lower winter elevation, the front faces 84 can reflect winter rays 42 incident thereto upward toward the under surface 86 of adjacent wires 80. In turn, the under surfaces 86 can reflect the solar rays back towards the building's surface 55 so the wire screen 50 functions as a collector. As further shown, the wires 80 can be separated by a predetermined distance D

so that at least some winter rays 43 can pass between the adjacent wires 80 and reflect directly onto the building's surface 55 to provide heating benefits.

Depending on the separation D of the wires 80 and the elevation of the sun relative to the screen 50, such directly passed rays 43 may occur in addition to and/or as an alternative to reflecting the rays 42 from the faces 84, to the surfaces 86, and to the building's surface 55. At certain times in the winter, for example, the wires 80 can allow for direct passage of some winter rays 43 between the wires 80 without reflection on the face 84 and under surfaces 86 when these rays 43 have a particular angular orientation to the screen 50. At other times during the winter, however, the wires' faces 84 and surfaces 86 can be designed to either reflect or not reflect the rays 42 to the building surface 55 that are incident to the wires' front faces 84.

FIG. 7 shows an end view of portion of a wire screen having yet another embodiment of wire 90. Again, these wires 90 have rear edges 92 that weld to the rods 54 of the screen 50 and have front faces 94 and under surfaces 96. As before, adjacent wires 90 are attached at a separation from one another on the rod 54 with a curved or bent channel 56 defined between each adjacent wire 90. As opposed to other embodiments, these wires 90 also have concave or bent back surfaces 98 facing the surface 55 and intended to reflect thermal radiation 44 from the surface 55 back towards it. This reflection may reduce heat loss from the building's surface 55 during the night, for example.

The foregoing description of preferred and other embodiments is not intended to limit or restrict the scope or applicability of the inventive concepts conceived of by the Applicants. In exchange for disclosing the inventive concepts contained herein, the Applicants desire all patent rights afforded by the appended claims. Therefore, it is intended that the appended claims include all modifications and alterations to the full extent that they come within the scope of the following claims or the equivalents thereof.

WHAT IS CLAIMED IS:

1. A solar wire screen, comprising:
 a plurality of rods vertically arranged parallel to one another on a
 back side of the wire screen; and
 5 a plurality of wires horizontally arranged parallel to one another on
 a front side of the wire screen, each of the wires at least including:
 a back edge attached to the rods,
 a front edge opposite the first edge and disposed away from the
 rods,
 10 a front face extending from the front edge and facing upward,
 a back surface oriented vertically at the back edge, and
 a surface extending from the front face towards the back edge and
 facing upwards,
 wherein the sun has a higher elevation on the horizon and a lower
 15 elevation on the horizon that is lower than the higher elevation,
 wherein the front faces reflect at least a portion of the solar energy
 incident thereto away from the front side of the wire screen when the sun has the
 higher elevation on the horizon,
 wherein the wires allow at least a portion of the solar energy to
 20 pass between the wires toward the back side of the wire screen when the sun
 has the lower elevation on the horizon,
 wherein the back surfaces reflect at least a portion of thermal
 radiation incident thereto back away from the back side of the wire screen, and
 wherein the surface extending from the front face towards the back
 25 edge and facing upwards reflects at least a portion of thermal radiation incident
 thereto back away from the back side of the wire screen.
2. The screen of claim 1, wherein the front faces face upward
 at an acute angle from vertical.

30

3. The screen of claim 1 or 2, wherein the wires have gaps therebetween, the gaps allowing at least some of the solar energy to pass directly between the wires toward the back side of the wire screen when the sun has the lower elevation.

5

4. The screen of claim 1, 2 or 3, wherein the wires comprise an under surface extending from the front edge and facing downward.

5. The screen of claim 4, wherein the front faces reflect at least a portion of the solar energy incident thereto toward an adjacent one of the under surfaces when the sun has the lower elevation on the horizon.

6. The screen of claim 4 or 5, wherein the under surfaces reflect at least a portion of the solar energy incident thereto that has been reflected from the front faces toward the back side of the wire screen.

7. The screen of claim 4, 5, or 6, wherein the under surfaces face downward at an acute angle from horizontal.

8. The screen of any one of claims 1 to 7, wherein the back side of the wire screen mounts adjacent an edifice.

9. The screen of claim 8, wherein a plurality of the wire screens are constructed as panels mounted onto the edifice.

25

10. The screen of any one of claims 1 to 9, further comprising a solar collector disposed adjacent the back side of the wire screen.

11. The screen of any one of claims 1 to 10, wherein the back edges weld to the rods.

30

12. The screen of any one of claims 1 to 11, wherein the front faces and back surfaces are polished.

5 13. The screen of any one of claims 1 to 12, wherein the front faces are flat or concave.

14. The screen of any one of claims 1 to 13, wherein the back surfaces are concave.

10 15. A solar wire screen, comprising:
 a plurality of rods vertically arranged parallel to one another on a back side of the wire screen; and
 a plurality of wires horizontally arranged parallel to one another on a front side of the wire screen, each of the wires at least including
 15 a first edge attached to the rods,
 a second edge opposite the first edge and disposed away from the rods,
 a first surface extending from the second edge and facing upward at a first acute angle from a vertical line passing adjacent the rods,
 20 a second surface extending from the second edge and facing downward at a second acute angle from the vertical line, the second acute angle being greater than the first acute angle, and
 a third surface extending from the first surface toward the first edge and facing upward at a third angle obtuse to the vertical line,
 25 the first surface passively reflecting at least a portion of the solar energy incident thereto away from the front side of the wire screen when the sun has a summer elevation on the horizon,
 the first surface passively reflecting at least a portion of the solar energy incident thereto toward the second surface of an adjacent wire when the
 30 sun has a winter elevation on the horizon,
 the second surface passively reflecting at least a portion of the solar energy incident thereto toward the edifice on the back side of the wire

screen, and

the third surface reflecting at least a portion of thermal radiation incident thereto back away from the back side of the wire screen.

5 16. The screen of claim 15, wherein the first edges comprise a back surface facing the back side of the wire screen and reflecting at least a portion of the thermal radiation incident thereto back away from the back side of the wire screen.

10 17. The screen of claim 15 or 16, wherein the first and second surfaces are polished.

18. The screen of claim 15, 16 or 17, wherein the first and second surfaces are flat or concave.

15

19. The screen of any one of claims 15 to 18, wherein the wires have gaps therebetween, the gaps allowing at least a portion of the solar energy to pass directly between the wires toward the back side of the wire screen when the sun has the winter elevation.

20

20. The screen of any one of claims 15 to 19, wherein the back side of the wire screen mounts adjacent an edifice.

25 21. The screen of claim 20, wherein the back side of the wire screen mounts adjacent an edifice.

22. The screen of any one of claims 15 to 21, further comprising a solar collector disposed adjacent the back side of the wire screen.

30 23. The screen of any one of claims 15 to 22, wherein the first edges weld to the rods.

24. The screen of any one of claims 16 to 23, wherein the back surface is concave.

5 25. A solar wire screen, comprising:
a plurality of rods vertically arranged parallel to one another on a
back side of the wire screen; and
a plurality of wires horizontally arranged parallel to one another on
a front side of the wire screen, each of the wires at least including
10 a back edge attached to the rods,
a front edge opposite the first edge and disposed away from the
rods,
a front face extending from the front edge and facing upward,
an under surface extending from the front edge and facing
15 downward, and
a surface extending from the front face towards the back edge and
facing upwards,
wherein the sun has a higher elevation on the horizon and a lower
elevation on the horizon that is lower than the higher elevation,
20 wherein the front faces reflect at least a portion of the solar energy
incident thereto away from the front side of the wire screen when the sun has the
higher elevation on the horizon,
wherein the front faces and the under surfaces of the wires allow at
least a portion of the solar energy to pass between the wires toward the back
25 side of the wire screen when the sun has the lower elevation on the horizon, and
wherein the surface extending from the front face towards the back
edge and facing upwards reflects at least a portion of thermal radiation incident
thereto back away from the back side of the wire screen.

30

26. The screen of claim 25, wherein the front faces face upward at an acute angle from vertical.

5 27. The screen of claim 25 or 26, wherein the back edges comprise a back surface oriented vertically and reflecting at least a portion of the thermal radiation incident thereto back away from the back side of the wire screen.

10 28. The screen of claim 25, 26 or 27, wherein the wires have gaps therebetween, the gaps allowing at least some of the solar energy to pass directly between the wires toward the back side of the wire screen when the sun has the lower elevation.

15 29. The screen of claim 28, wherein the front faces reflect at least a portion of the solar energy incident thereto toward an adjacent one of the under surfaces when the sun has the lower elevation on the horizon.

20 30. The screen of claim 28 or 29, wherein the under surfaces reflect at least a portion of the solar energy incident thereto that has been reflected from the front faces toward the back side of the wire screen.

31. The screen of claim 28, 29, or 30, wherein the under surfaces face downward at an acute angle from horizontal.

25 32. The screen of any one of claims 25 to 31, wherein the back side of the wire screen mounts adjacent an edifice.

33. The screen of claim 32, wherein a plurality of the wire screens are constructed as panels mounting onto the edifice.

30

34. The screen of any one of claims 25 to 33, further comprising a solar collector disposed adjacent the back side of the wire screen.

5 35. The screen of any one of claims 25 to 34, wherein the back edges weld to the rods.

10 36. The screen of any one of claims 25 to 35, wherein the front faces, the under surfaces, and the surfaces extending from the front faces towards the back edges and facing upwards are polished.

37. The screen of any one of claims 25 to 36, wherein the front faces, the under surfaces, and the surfaces extending from the front faces towards the back edges and facing upwards are flat or concave.

15 38. The screen of any one of claims 27 to 37, wherein the back surface is concave.

39. A solar wire screen mountable vertically adjacent an edifice, the wire screen comprising:

20 a plurality of rods vertically arranged parallel to one another on a back side of the wire screen; and

a plurality of wires horizontally arranged parallel to one another on a front side of the wire screen, each of the wires at least including:

25 a first edge attached to the rods,
a second edge opposite the first edge and disposed away from the rods,

a first surface extending from the second edge and facing upward at a first acute angle from a vertical line passing adjacent the rods,

30 a second surface extending from the second edge and facing downward at a second acute angle from the vertical line, the second acute angle being greater than the first acute angle, and

a third surface extending from the first surface toward the first edge and facing upward at a third angle obtuse to the vertical line,

wherein the first surfaces reflect at least a portion of the solar energy incident thereto away from the front side of the wire screen when the sun
5 has a summer elevation on the horizon,

wherein the first and second surfaces of the wires pass at least a portion of the solar energy toward the edifice adjacent the back side of the wire screen when the sun has a winter elevation on the horizon, and

wherein the third surface reflects at least a portion of thermal
10 radiation incident thereto back to the edifice away from the back side of the wire screen.

40. The screen of claim 39, wherein the first edges comprise a back surface oriented vertically and reflecting at least a portion of the thermal
15 radiation incident thereto back away from the back side of the wire screen.

41. The screen of claim 39 or 40, wherein the wires have gaps therebetween, the gaps allowing at least some of the solar energy to pass directly between the wires toward the back side of the wire screen when the sun
20 has the winter elevation.

42. The screen of claim 39, 40, or 41, wherein the first surfaces reflect at least a portion of the solar energy incident thereto toward an adjacent one of the second surfaces when the sun has the winter elevation on the horizon.
25

43. The screen of any one of claims 39 to 42, wherein the second surfaces reflect at least a portion of the solar energy incident thereto that has been reflected from the first surface toward the back side of the wire screen.

30 44. The screen of any one of claims 39 to 43, wherein a plurality of the wire screens are constructed as panels mounting onto the edifice.

45. The screen of any one of claims 39 to 44, further comprising a solar collector disposed adjacent the back side of the wire screen.

5 46. The screen of any one of claims 39 to 45, wherein the first edges weld to the rods.

47. The screen of any one of claims 39 to 46, wherein the first, second, and third surfaces are polished.

10

48. The screen of any one of claims 39 to 47, wherein the first, second, and third surfaces are flat or concave.

15 49. The screen of any one of claims 40 to 48, wherein the back surface is concave.

1/4
FIG. 1
(Prior Art)

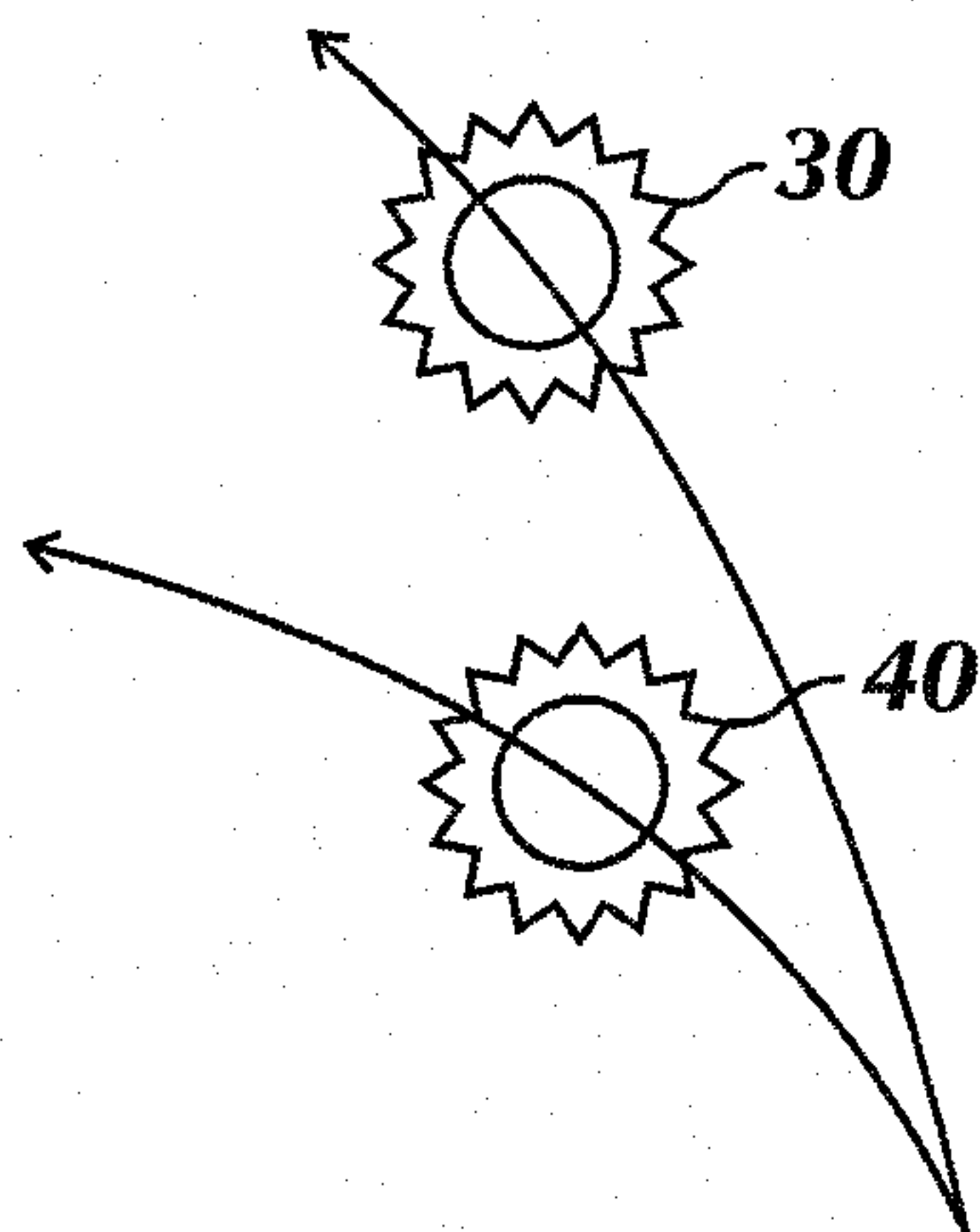
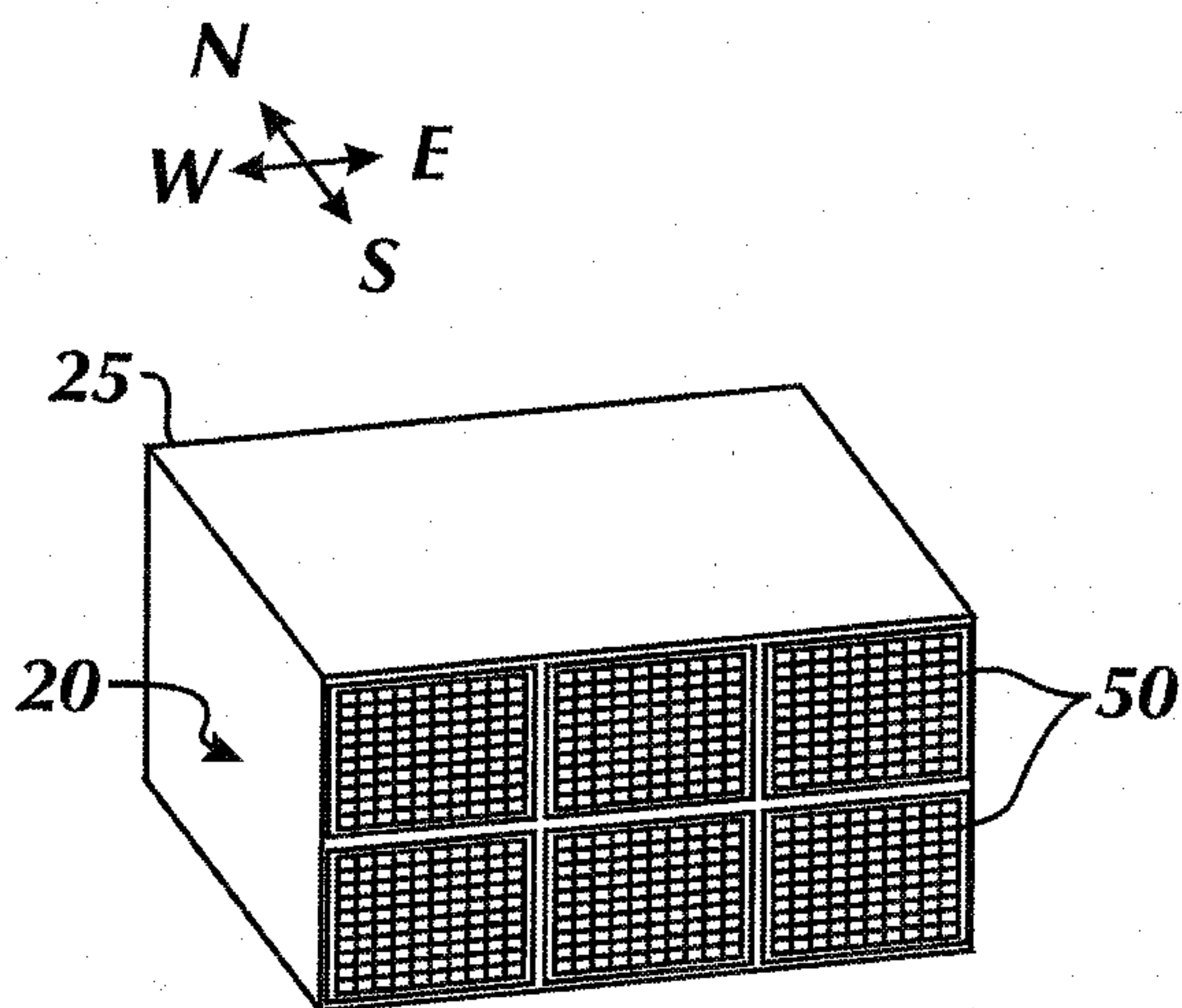
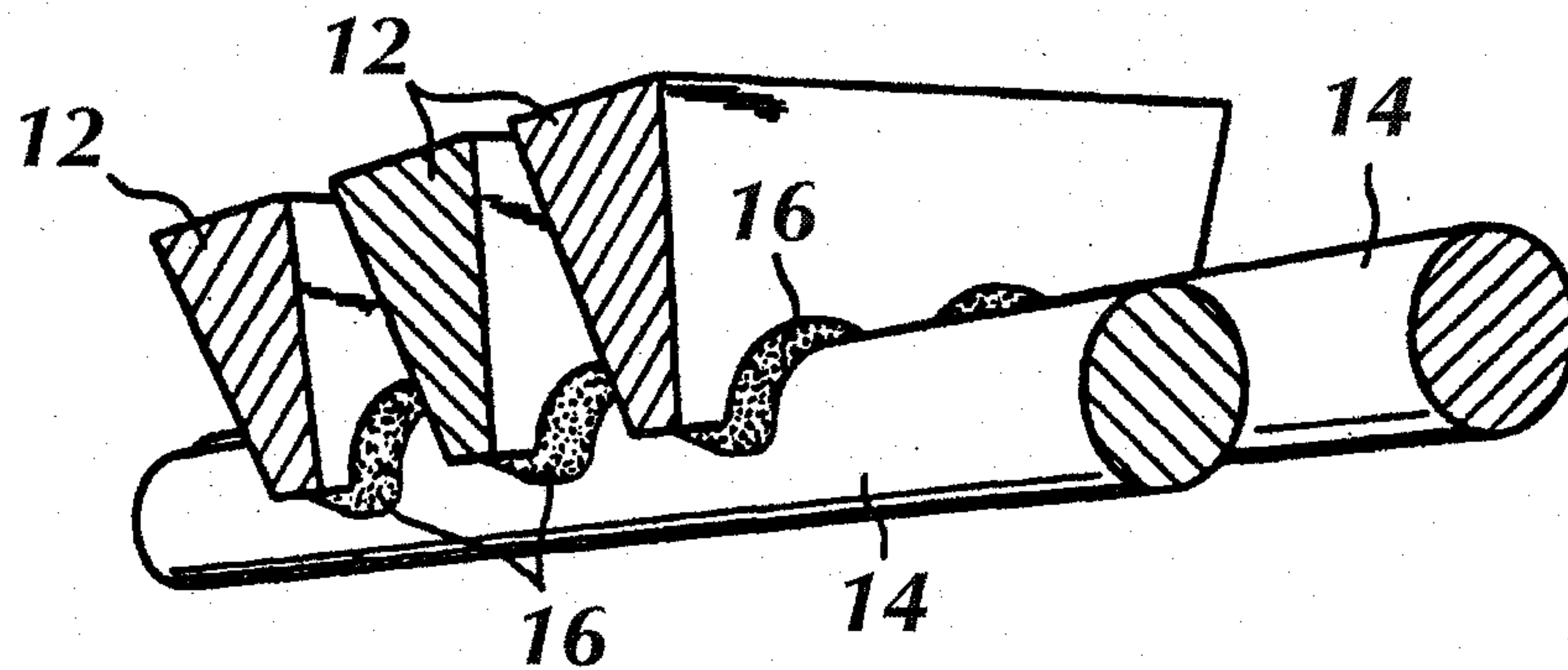

FIG. 2

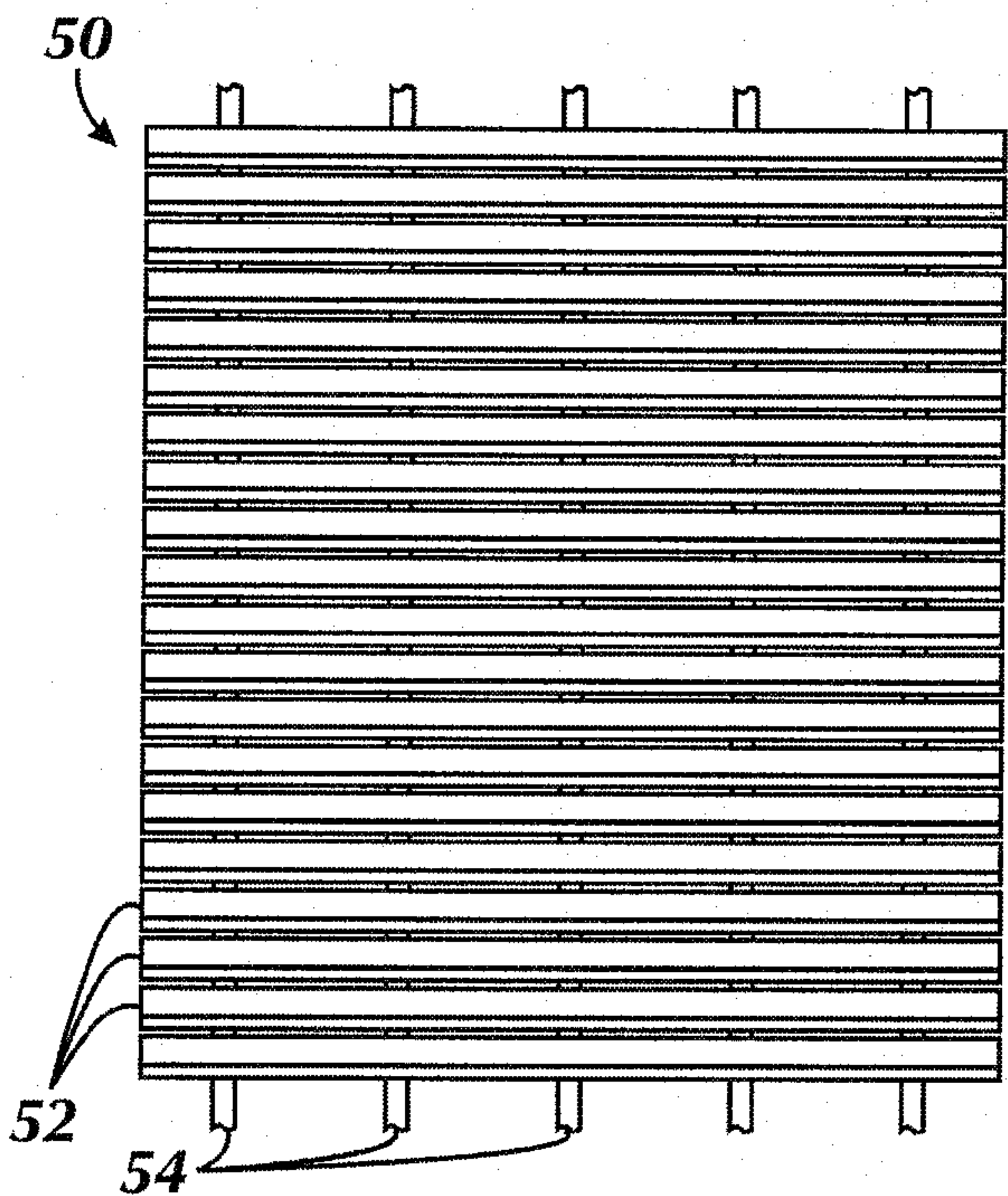

FIG. 3A

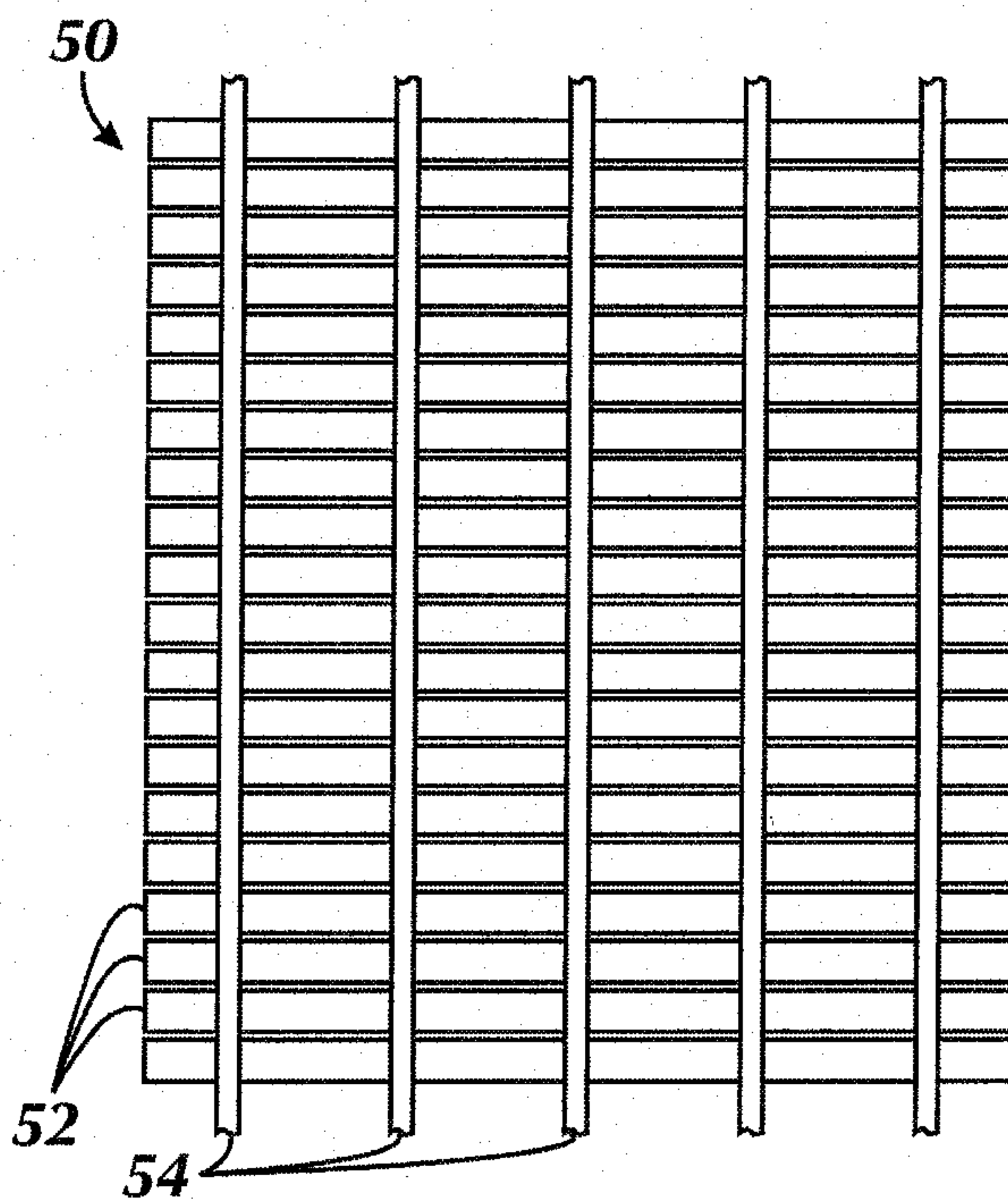
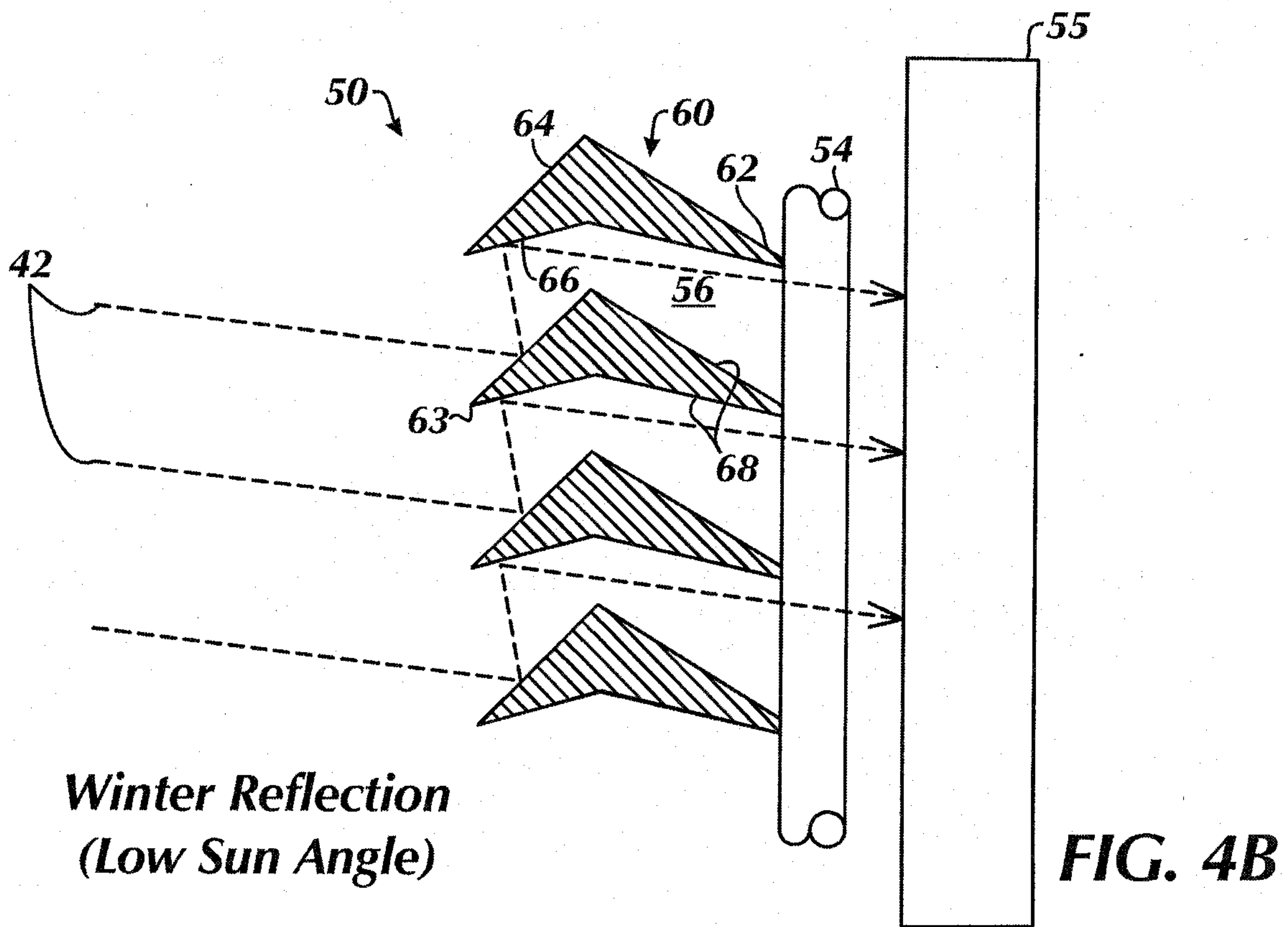
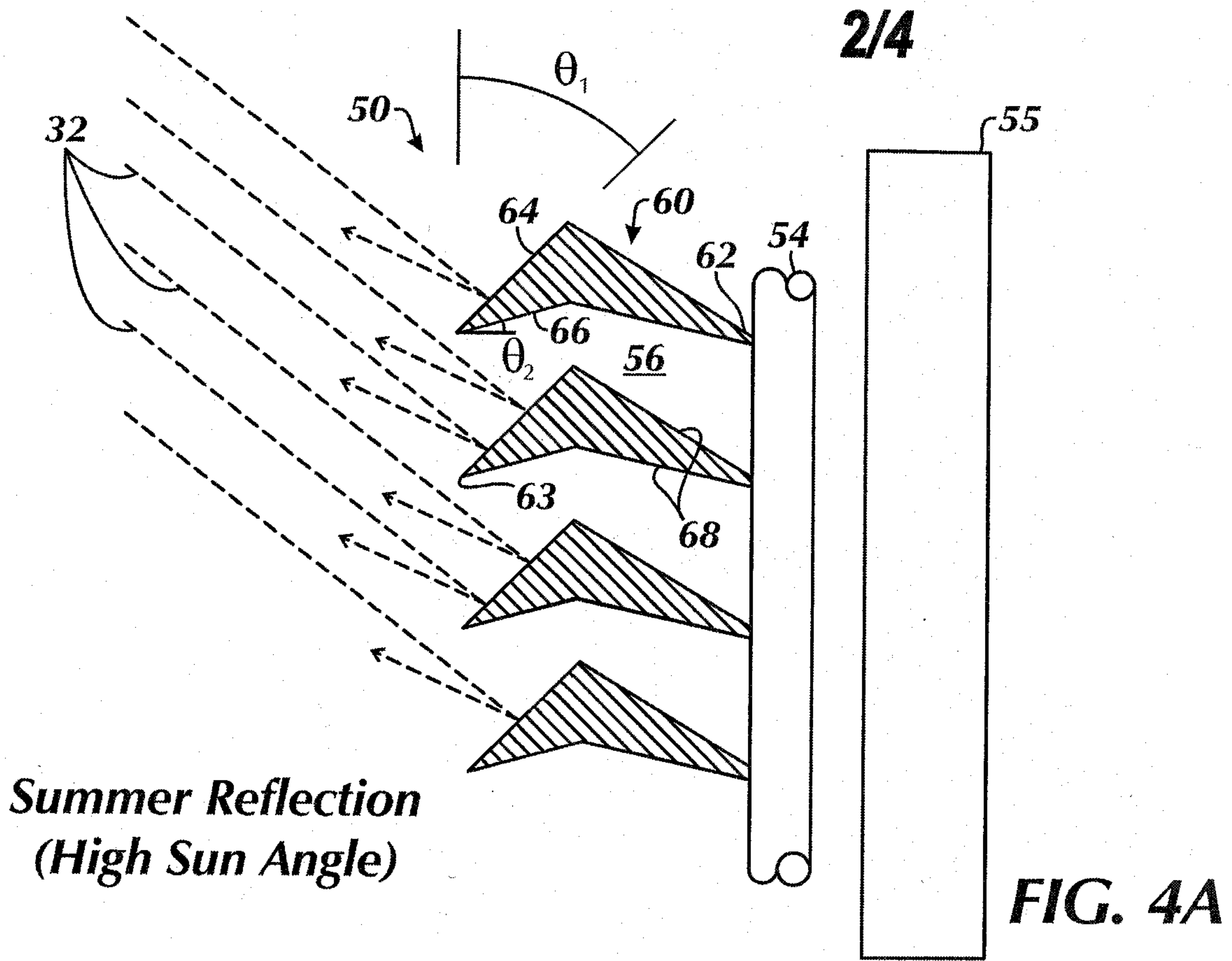
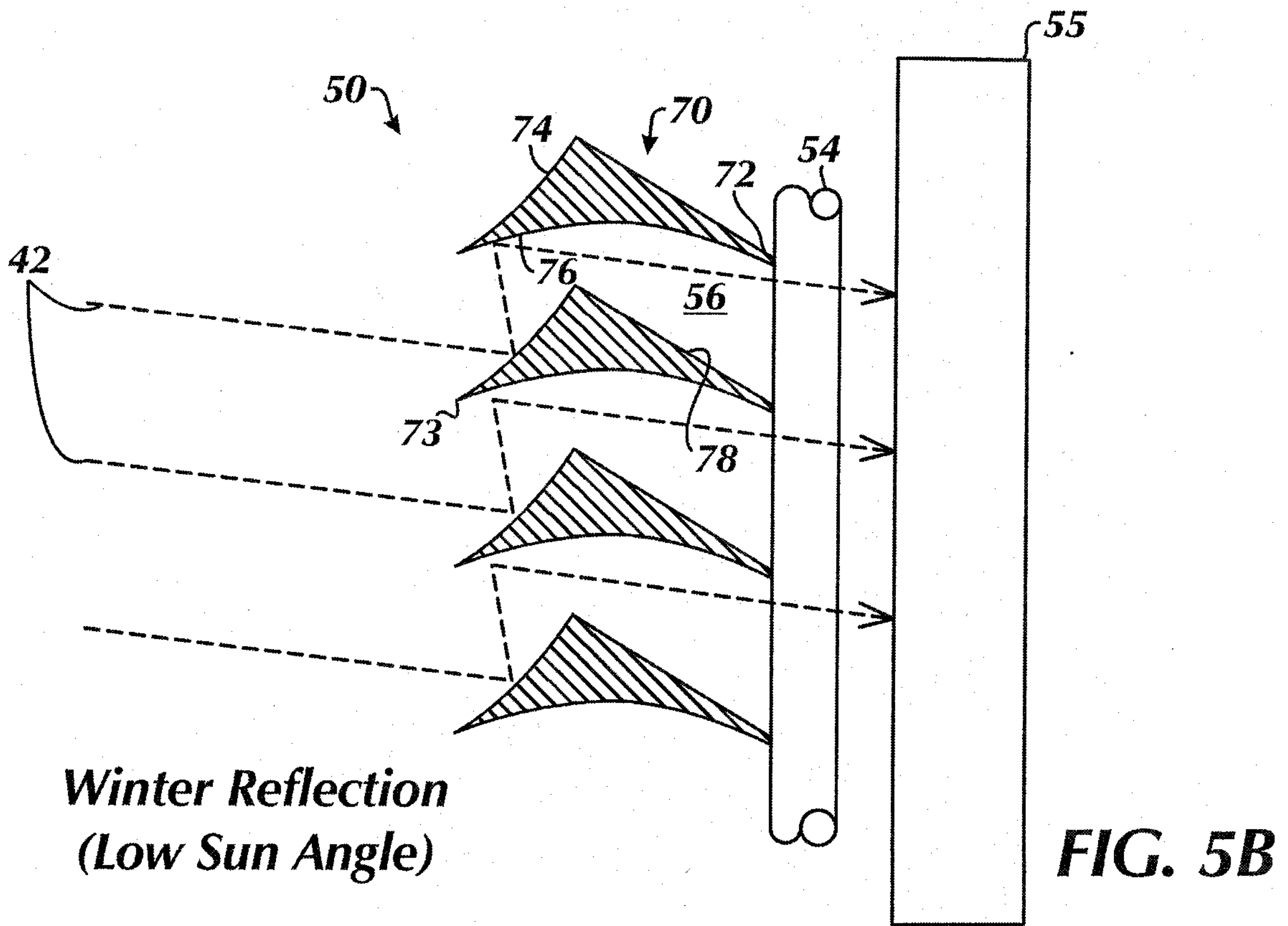
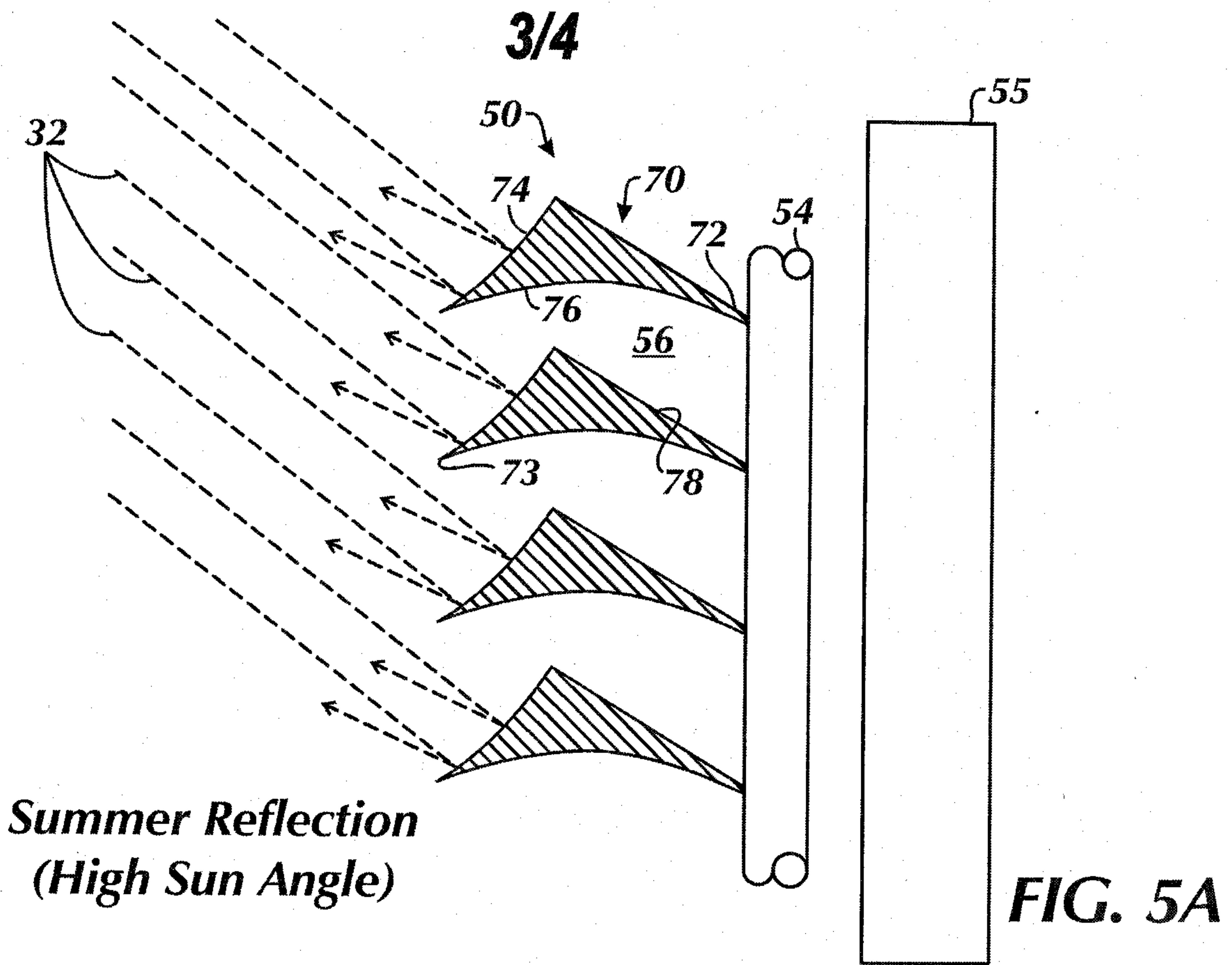

FIG. 3B





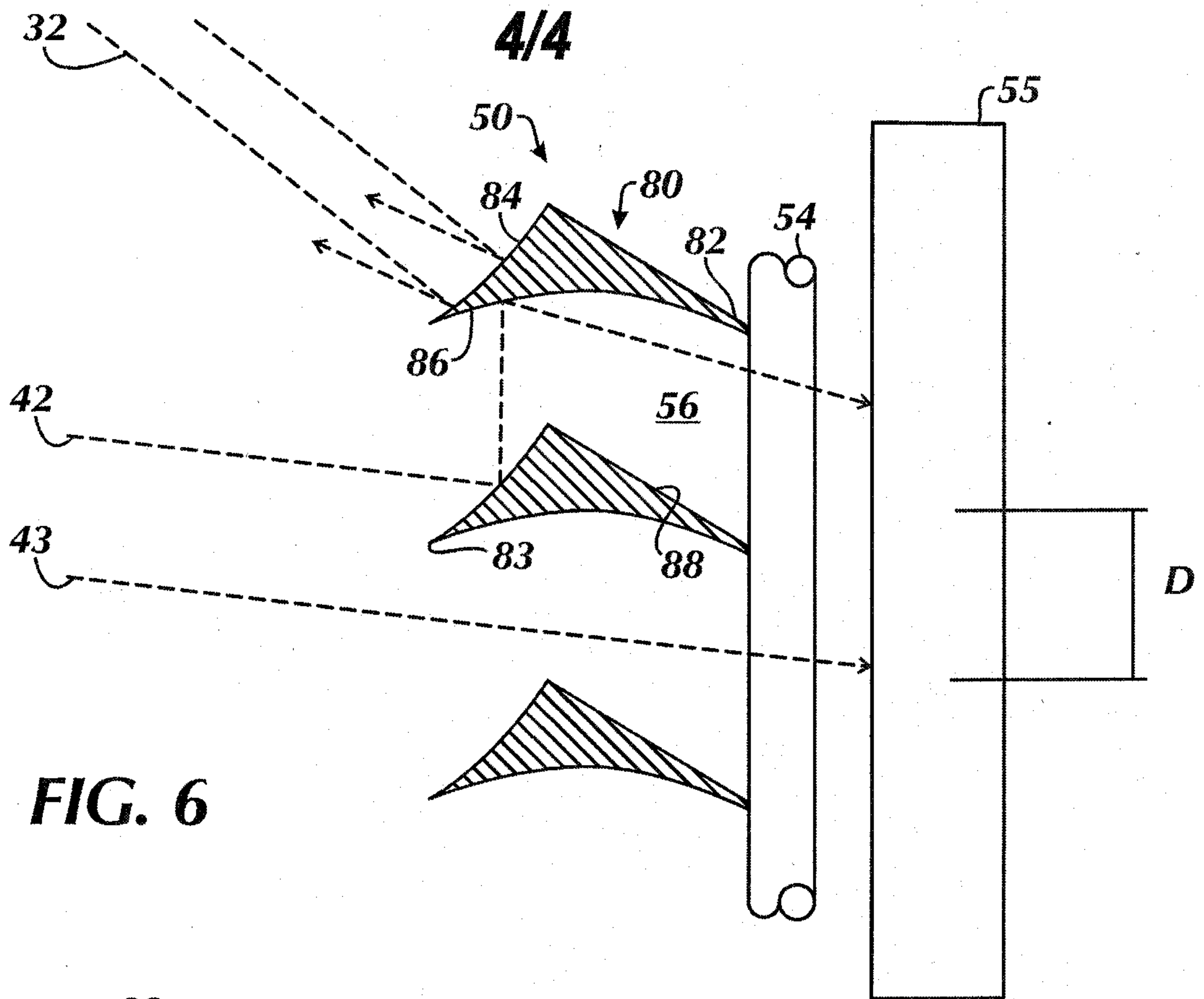

FIG. 6

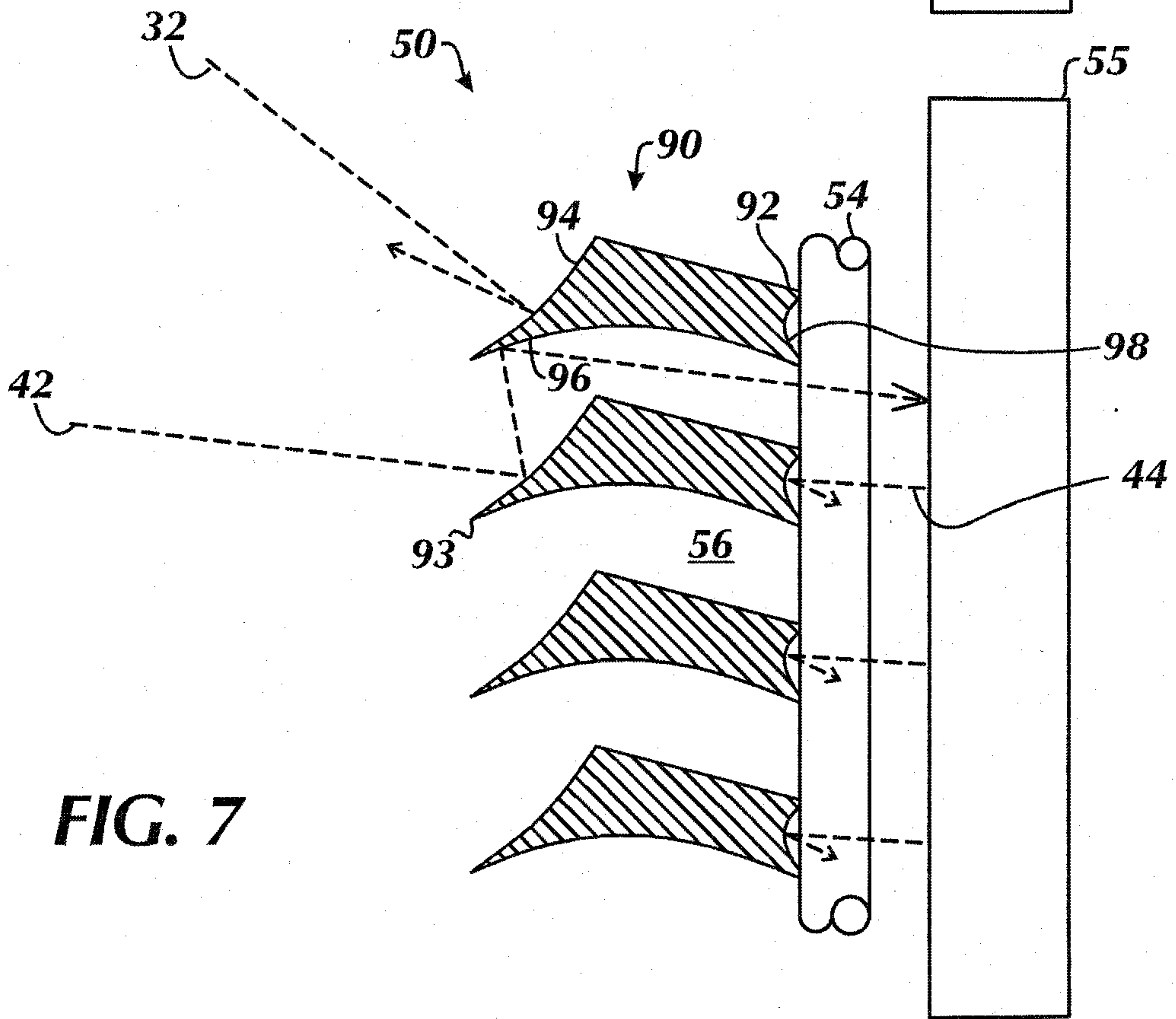
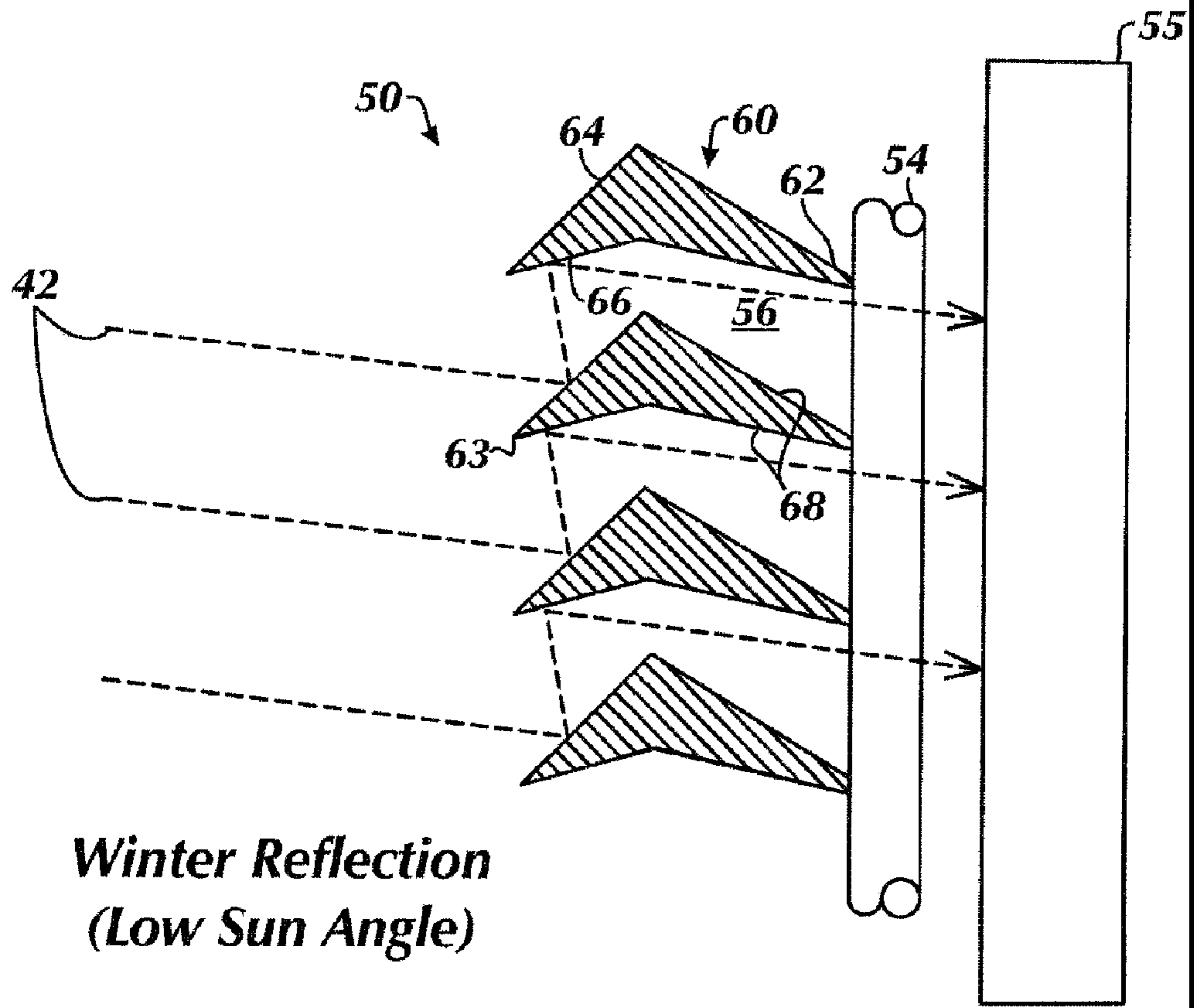

FIG. 7



***Winter Reflection
(Low Sun Angle)***