



US 20040103478A1

(19) **United States**

(12) **Patent Application Publication**

Ellis et al.

(10) **Pub. No.: US 2004/0103478 A1**

(43) **Pub. Date: Jun. 3, 2004**

(54) **FLUID SUPPLY APPARATUS FOR A MATTRESS**

(76) Inventors: **Craig D. Ellis**, Charleston, SC (US); **Kenith W. Chambers**, Charleston, SC (US); **Stephen E. Glover**, Charleston, SC (US); **Kerry J. Mensching**, Mt. Pleasant, SC (US)

Correspondence Address:
Timothy E. Niednagel
Bose McKinney & Evans LLP
Suite 2700
135 North Pennsylvania Street
Indianapolis, IN 46204 (US)

(21) Appl. No.: **10/719,183**

(22) Filed: **Nov. 21, 2003**

Related U.S. Application Data

- (62) Division of application No. 09/509,452, filed on Mar. 21, 2000, filed as 371 of international application No. PCT/US98/17493, filed on Aug. 24, 1998.
- (60) Provisional application No. 60/056,791, filed on Aug. 25, 1997.

Publication Classification

- (51) **Int. Cl.⁷** **A47C 27/08**
- (52) **U.S. Cl.** **5/713**

(57) **ABSTRACT**

A fluid supply apparatus includes a housing which is selectively coupled to a portion of a bed in either a first orientation or a second orientation.

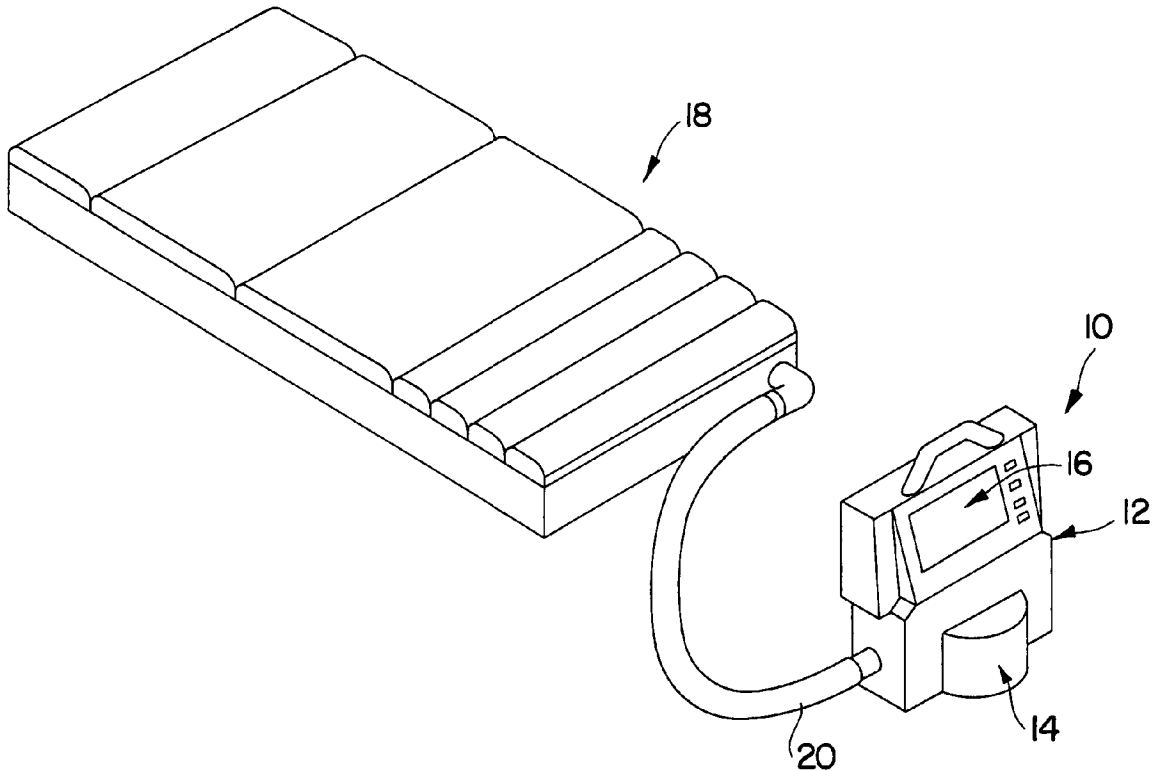

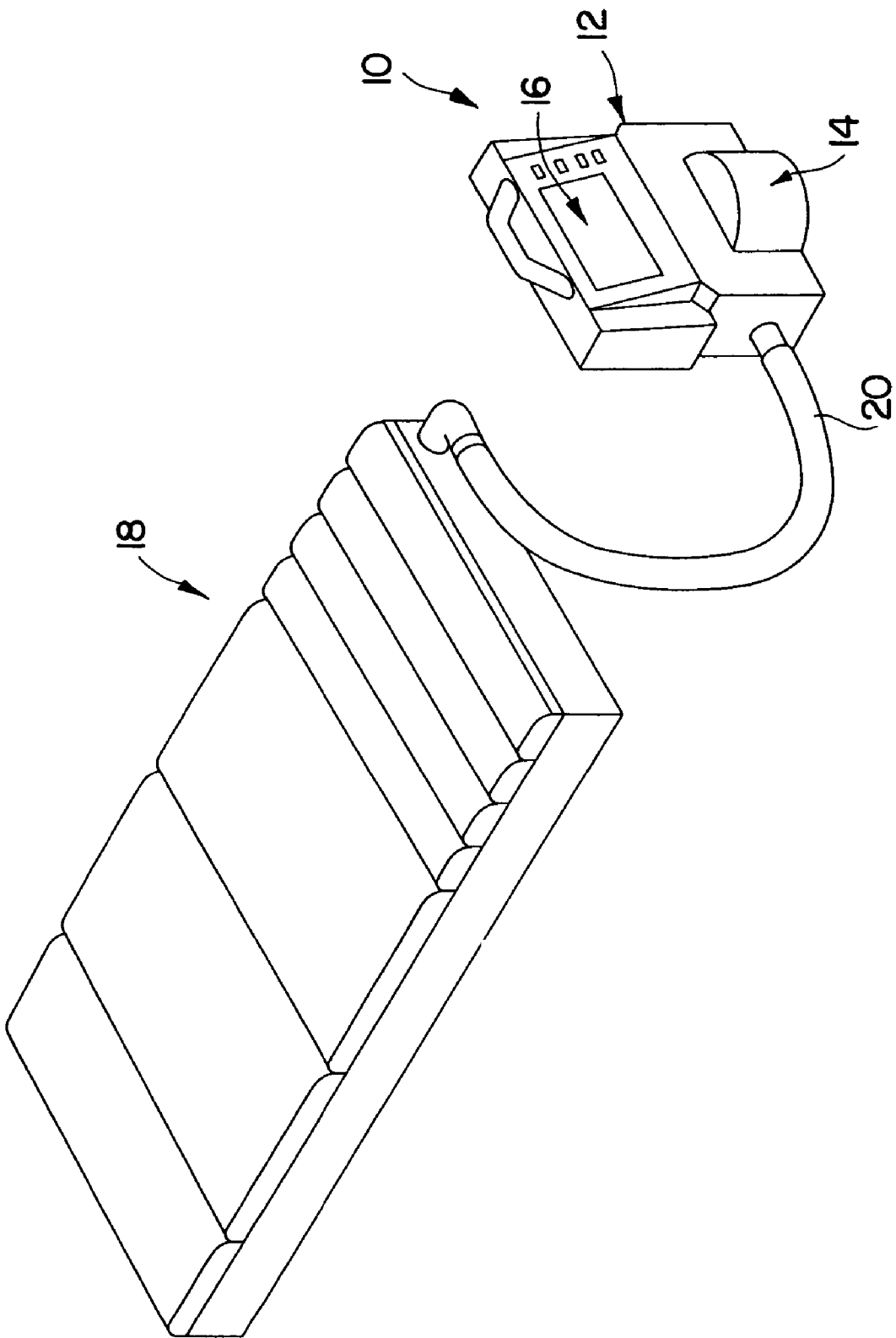

FIG. 1

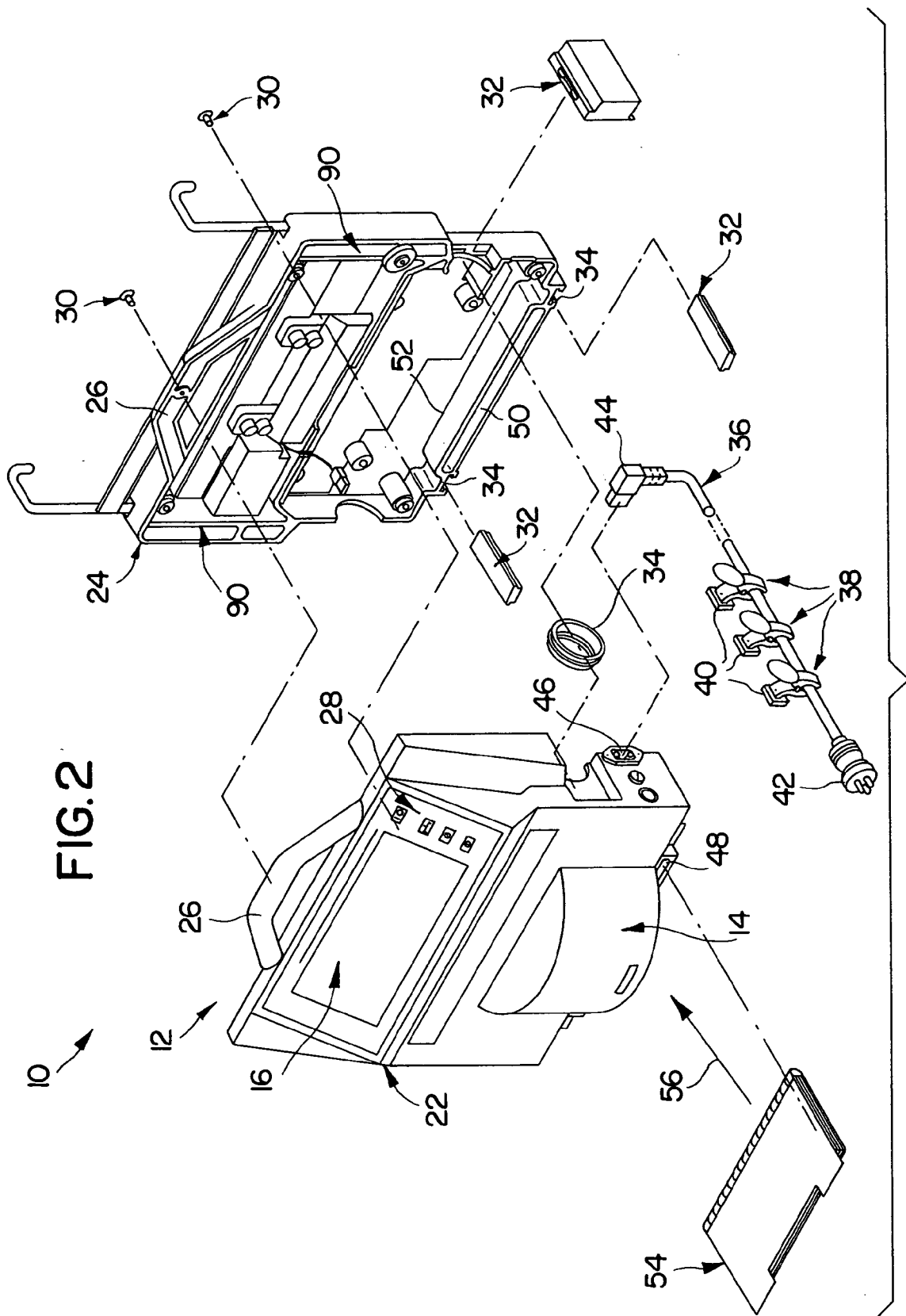
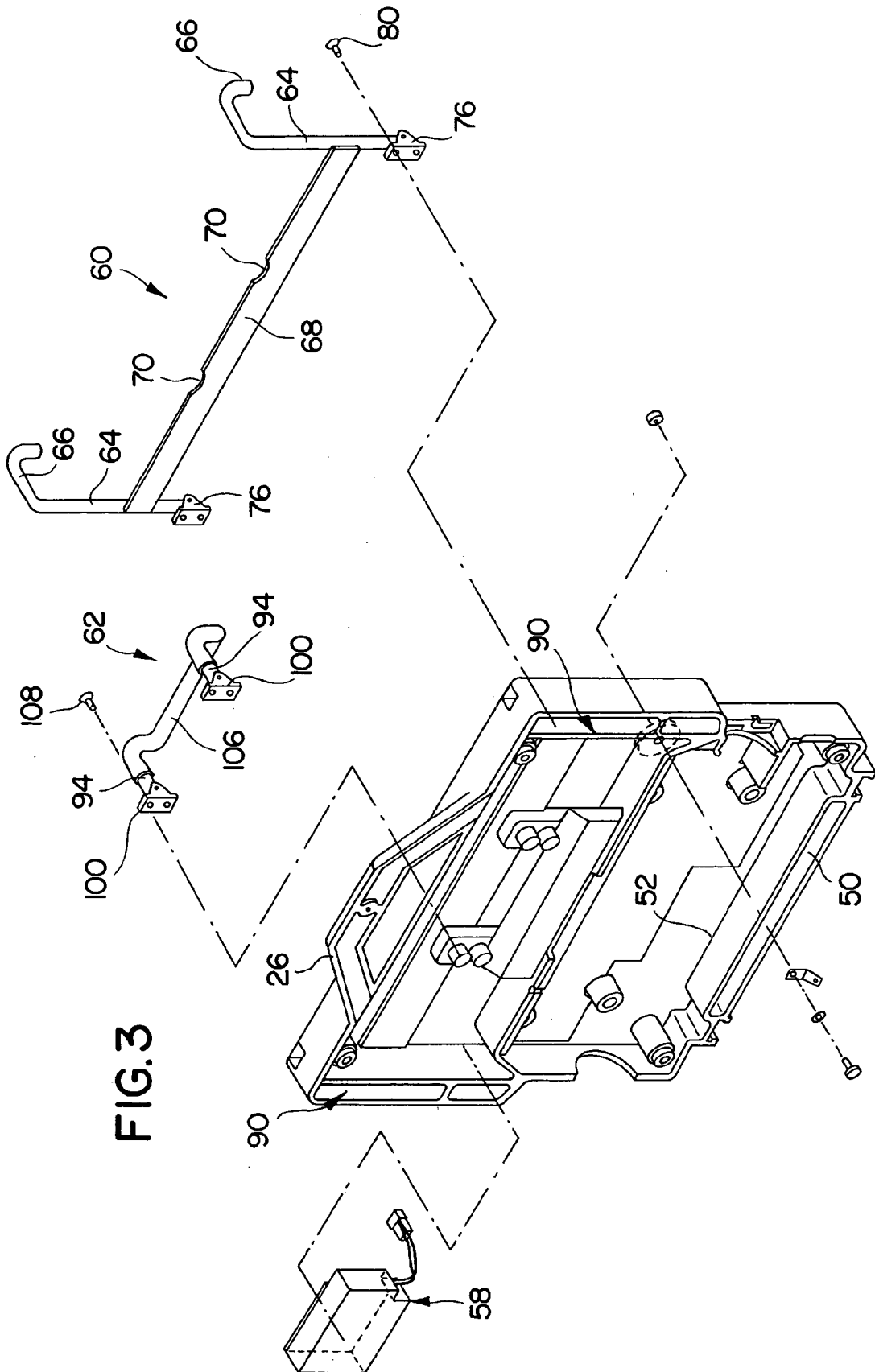

FIG. 2



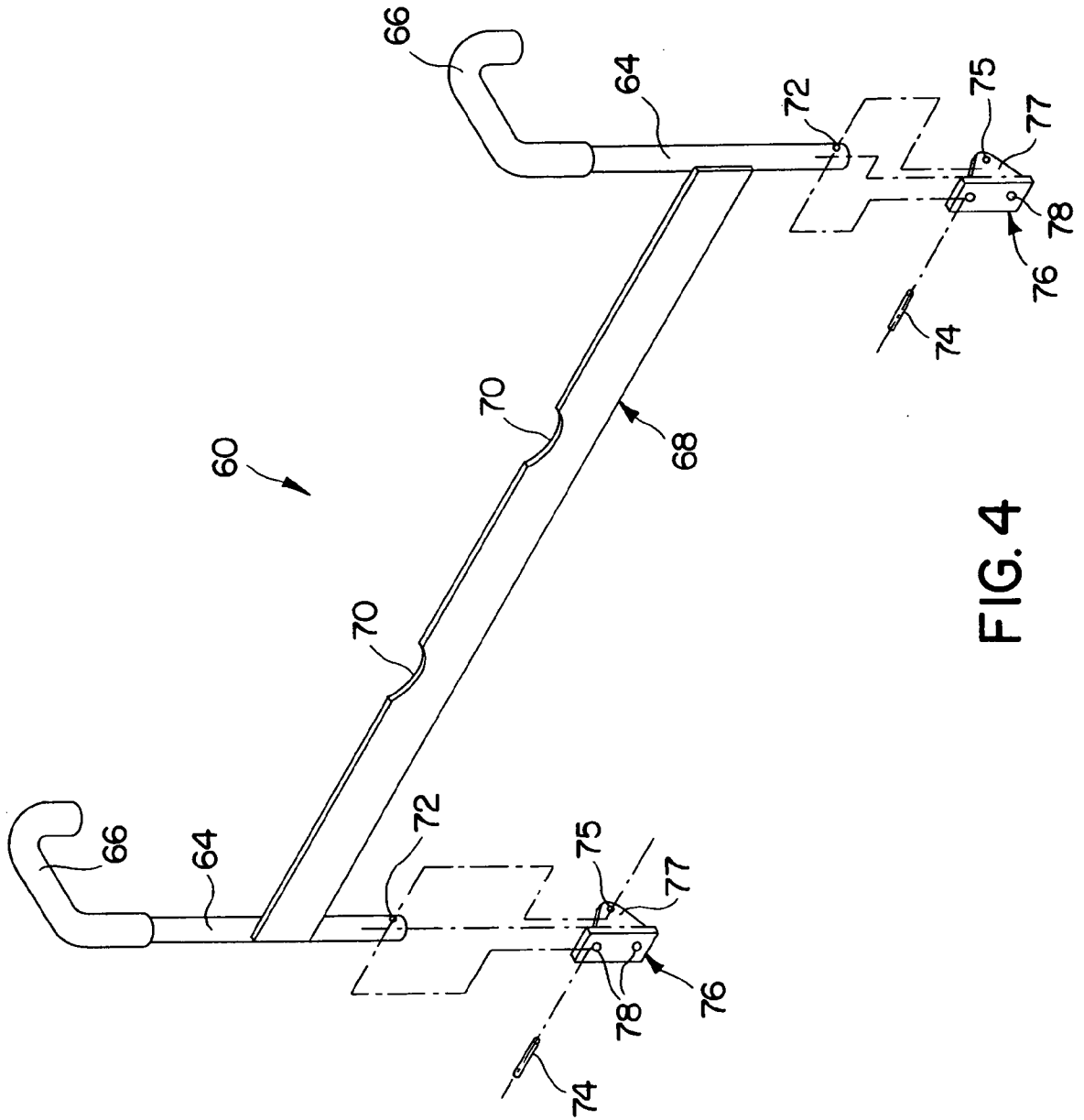

FIG. 4

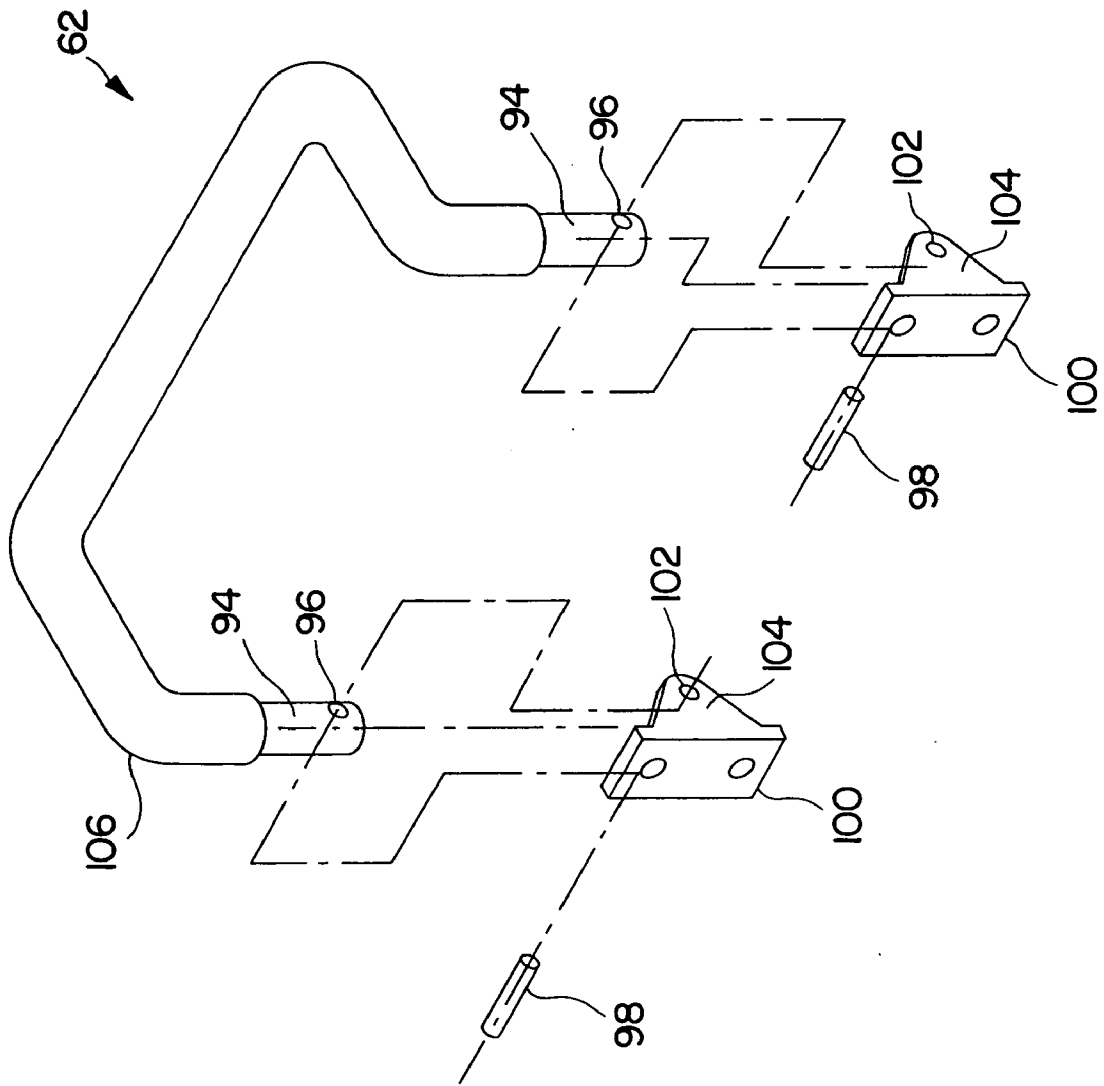
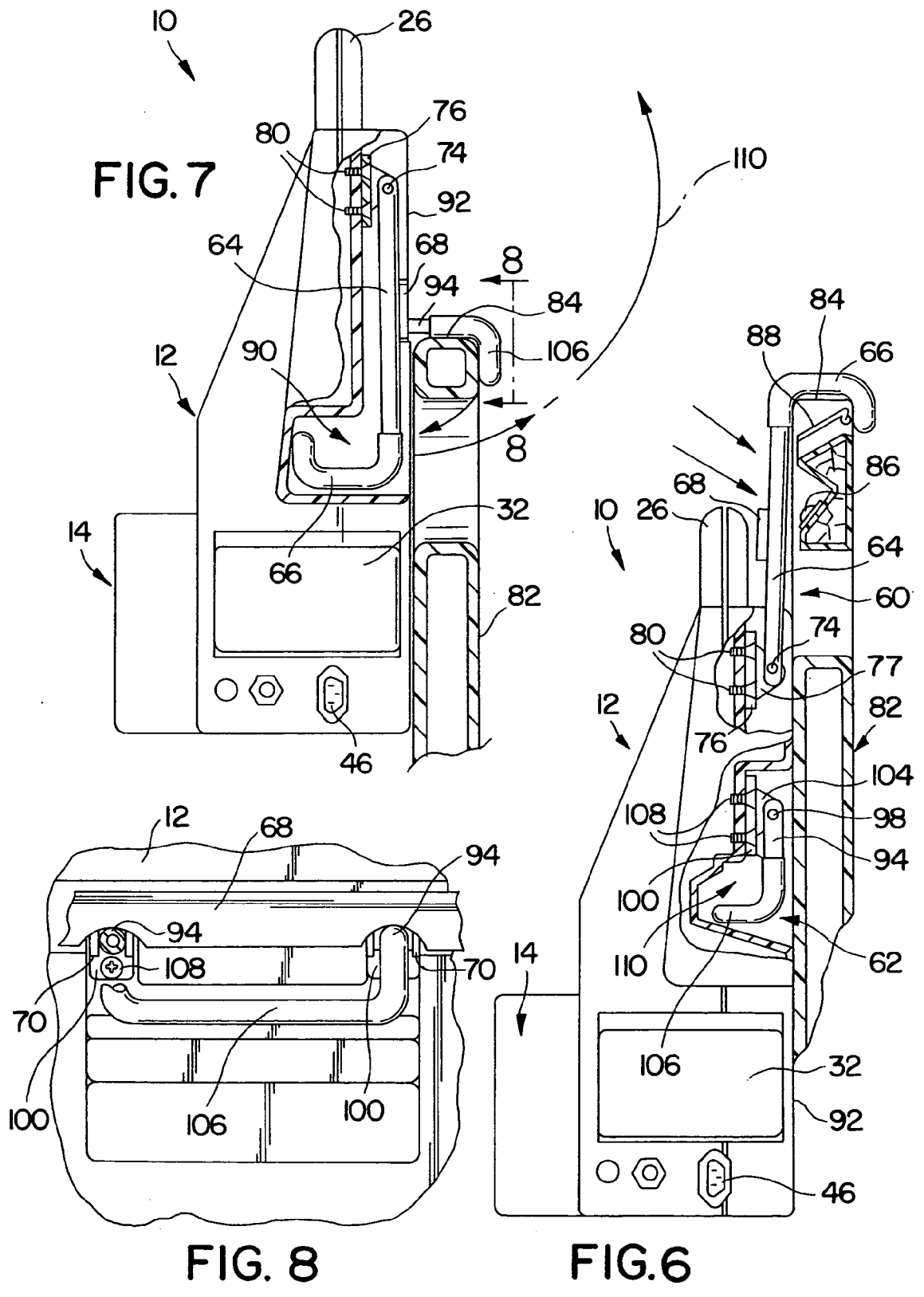

FIG. 5



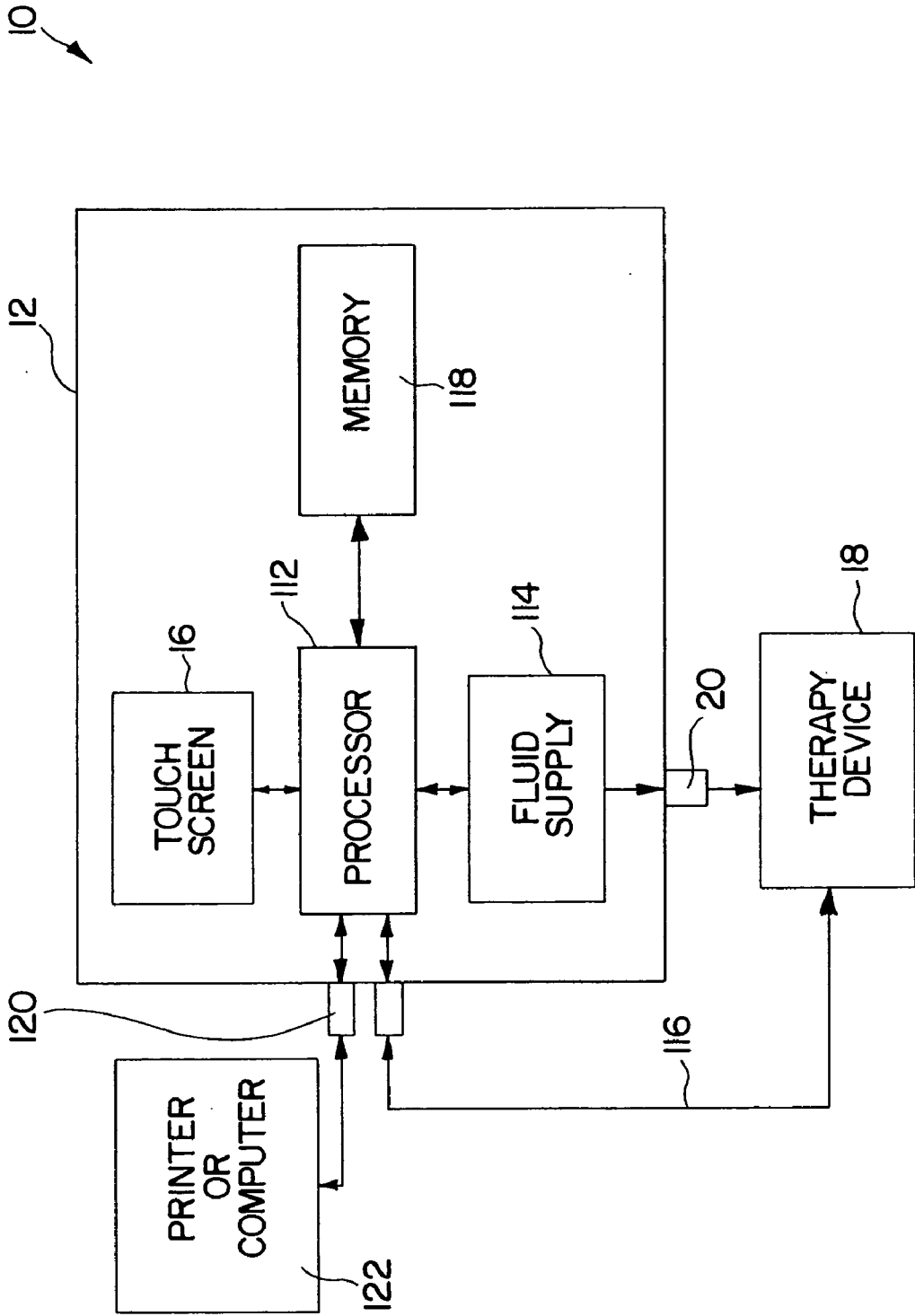

FIG. 9

FLUID SUPPLY APPARATUS FOR A MATTRESS**BACKGROUND AND SUMMARY OF THE INVENTION**

[0001] This application is a divisional of U.S. application Ser. No. 09/509,452, filed Mar. 21, 2000, which is the national phase under 35 U.S.C. § 371 of PCT International Application No. PCT/US98/17493, having an International filing date of Aug. 24, 1998, which claims the benefit of U.S. Provisional Application No. 60/056,791, filed on Aug. 25, 1997, all of which are expressly incorporated herein by reference.

[0002] The present invention relates to an air supply apparatus. More particularly, the present invention relates to an improved air supply apparatus for controlling fluid flow to desired pieces of equipment, such as air mattress, therapy devices, or other components of a bed. Although the illustrated embodiments of the present invention disclose air blowers, it is understood that the present invention may also be useful with other types of fluid.

[0003] The air supply apparatus of the present invention is used to provide air or other type of fluid to an air mattress, to support a patient and to provide therapy to a patient. The air supply apparatus includes a housing which may be located on the floor adjacent a bed to control the air mattress or therapy device. In addition, the air supply apparatus may be coupled to a footboard of the bed in two different orientations, depending upon the configuration of the footboard and the desires of a caregiver.

[0004] The illustrated air supply apparatus includes a blower motor or compressor for supplying air to the mattress or therapy device. The air supply apparatus further includes a controller to provide rotation, percussion, and vibration therapies and to adjust pressure within air bladders in the mattress to enhance patient comfort. The illustrated controller includes a microprocessor located within the housing of the air supply unit. The processor stores data related to the therapies performed. This stored data can be downloaded through an output port located on the housing to a printer or computer. In other words, the air supply apparatus of the present invention includes a controller having a memory which stores the particular key strokes or therapies provided to a patient by the device. This historical information can then be printed or downloaded to a computer to analyze the data.

[0005] A control panel of the air supply apparatus is located on the housing. Various menus are displayed on the control panel. Features and therapies are controlled by a touch screen panel which provides increased flexibility of menu driven functions compared to membrane switches typically used on control panels of air supplies.

[0006] According to one aspect of the present invention, a fluid supply apparatus is provided for supplying fluid to a therapy device on a bed having a footboard. The apparatus includes a housing, a fluid supply located within the housing, a first hanger coupled to the housing, and a second hanger coupled to the housing. The first hanger is configured to couple the housing to the footboard in a first orientation, and the second hanger is configured to couple the housing to the footboard in a second orientation.

[0007] In the illustrated embodiment, the first and second hangers are pivotably coupled to a rear wall of the housing.

The housing is formed to include first and second recessed portions adjacent the rear wall which are configured to receive the first and second hangers, respectively, in downwardly pivoted, storage positions. The first and second hangers are located inwardly from the rear wall of the housing when the first and second hangers are in the storage positions.

[0008] Also in the illustrated embodiment, the first hanger includes first and second spaced apart arms pivotably coupled to the housing. The first and second arms each include a hook portion configured to engage a top edge of the footboard to couple the housing to the footboard. A cross bar is coupled between the first and second arms of the first hanger. The cross bar is formed to include notched portions configured to engage the second hanger when the second hanger is in an outwardly pivoted position relative to the housing to hold the second hanger in a position to engage the footboard.

[0009] The second hanger includes first and second arms pivotably coupled to the housing and a U-shaped portion coupled between the first and second arms to define a hook configured to engage a top edge of the footboard. A protective coating is located over the U-shaped portion of the second hanger. The arms of the first hanger have a length greater than the arms of the second hanger. The arms of the first hanger are also spaced apart further than the arms of the second hanger.

[0010] According to another aspect of the present invention, a fluid supply apparatus is provided for controlling a therapy device. The apparatus includes a housing, a fluid supply located within the housing, a processor located within the housing, and a touch screen control panel coupled to the housing. The fluid supply is configured to be coupled to the therapy device. The processor is configured to be electrically coupled to the therapy device. The touch screen control panel is electrically coupled to the processor to receive operator inputs to control the therapy device.

[0011] In the illustrated embodiment, a memory located within the housing. The memory is coupled to the processor to store data related to inputs from the touch screen. A communication port is also coupled to the housing. The communication port is coupled to the processor and configured to be coupled to a computer to download information from the memory to the computer. The communication port is also configured to be coupled to a printer to print information stored in the memory. The computer can also upload information related to the therapy device to the processor. The computer transmits a menu for controlling the therapy device to the processor to be displayed on the touch screen control panel.

[0012] According to yet another aspect of the present invention, a fluid supply apparatus is provided for a therapy device. The apparatus includes a housing formed to include an elongated slot configured to define a storage receptacle, a fluid supply located within the housing, and a controller located within the housing. The fluid supply is configured to be coupled to the therapy device, and the controller is coupled to the fluid supply.

[0013] In the illustrated embodiment, a user manual configured to be inserted into the storage receptacle. The slot is formed adjacent a bottom end of the housing below the fluid

supply. The housing includes a front case and a rear case configured to be coupled together to define the housing. A first portion of the slot is formed by the first case, and a second portion of the slot is formed by the second case.

[0014] According to still another aspect of the present invention, a fluid supply apparatus is provided for controlling a therapy device. The apparatus includes a housing, a fluid supply located within the housing, a processor located within the housing, the processor being configured to be electrically coupled to the therapy device, and a memory located within the housing. The fluid supply is configured to be coupled to the therapy device, and the memory is coupled to the processor to store data. The apparatus also includes a control panel coupled to the housing. The control panel is electrically coupled to the processor to receive operator inputs to control the therapy device. The apparatus further includes a communication port coupled to the housing. The communication port is coupled to the processor and configured to be coupled to a computer to download information from the memory to the computer. The computer is also configured upload information related to the therapy device to the processor.

[0015] Additional features and advantages of the invention will become apparent to those skilled in the art upon consideration of the following detailed description of the illustrated embodiment exemplifying the best mode of carrying out the invention as presently perceived.

BRIEF DESCRIPTION OF THE DRAWINGS

[0016] The detailed description particularly refers to the accompanying figures in which:

[0017] **FIG. 1** is a perspective view illustrating an air supply apparatus of the present invention coupled to an air mattress by an air supply hose;

[0018] **FIG. 2** is an exploded perspective view of the air supply apparatus of **FIG. 1**;

[0019] **FIG. 3** is an exploded perspective view of a rear case assembly of a housing of the air supply apparatus;

[0020] **FIG. 4** is an exploded perspective view of a large hanger assembly for mounting the air supply apparatus to a footboard of a bed in a first orientation;

[0021] **FIG. 5** is an exploded perspective view of a small hanger assembly for mounting the air supply apparatus on the footboard of the bed in a second orientation;

[0022] **FIG. 6** is a side elevational view, with portions broken away, illustrating the air supply apparatus mounted on a footboard of a bed in the first orientation by the large hanger assembly;

[0023] **FIG. 7** is a side elevational view, with portions broken away, illustrating the air supply apparatus mounted on the footboard of the bed in the second orientation by the small hanger assembly;

[0024] **FIG. 8** is a rear elevational view taken along lines 8-8 of **FIG. 7**, with portions broken, illustrating further details of the small hanger assembly coupled to the footboard; and

[0025] **FIG. 9** is a block diagram illustrating further details of the air supply apparatus.

DETAILED DESCRIPTION OF THE DRAWINGS

[0026] Referring now to the drawings, **FIG. 1** illustrates an air supply apparatus **10** of the present invention including a housing **12** having a lower section **14** for receiving a blower motor and a touch screen control panel **16** for controlling operation of the air supply apparatus **10** and the therapies being performed on a therapy device such as an air mattress **18**. Air supply apparatus **10** is coupled to the mattress **18** pneumatically by air supply tube **20**. A controller of air supply apparatus **10** is also electrically coupled to the therapy device **18** by an electrical wire running through the air supply hose **20**. Further details of the therapy mattress are disclosed in U.S. Pat. No. 6,021,533, the disclosure of which is incorporated herein by reference. In addition, valve assemblies for controlling therapies and air flow to various air bladders within the mattress **18** are disclosed in U.S. Pat. No. 6,202,672, the disclosure of which is incorporated herein by reference.

[0027] Details of the air therapy apparatus **10** are illustrated in **FIGS. 2-8**. Referring now to **FIG. 2**, the housing **12** includes a front case assembly **22** and a rear case assembly **24**. Each of the front and rear case assemblies **22** and **24** is formed to include a portion of handle **26** for carrying the housing **12**. Front case assembly **22** includes section **14** for receiving the blower motor or other fluid supply (not shown). Front case assembly **22** also includes a control panel **16** which is illustratively a touch screen control panel which can be cleaned with a soft damp cloth. The touch screen control panel **16** is actuated by an operator touching desired portions of the screen of control panel **16**.

[0028] The touch screen control panel **16** provides increased flexibility for menu driven functions compared to membrane-type switches which are typically used on air supply housings. Function control buttons **28** are located adjacent control panel **16**. Control buttons **28** illustratively include a CPR button, a maximum inflate button, an alarm silence button, and a therapy on/off control button. The front and rear case assemblies **22** and **24** are coupled together by suitable fasteners **30** to form the housing **12**.

[0029] Filter cover **32** is located over an air intake portion of the housing **12**. T-shaped elongated feet **32** slide into T-shaped slots **34** formed on opposite sides of front and rear case assemblies **22** and **24**. Feet **32** support the housing **12** on the ground. Air supply apparatus **10** further includes an inlet flange **34** and a power cord **36** having any desired length. Magnetic clip assemblies **38** include magnets **40** configured to be coupled to any metal member on the bed frame. The clips **38** retain the power cord **36** in an out of the way position. Power cord **36** includes a plug **42** at one end and a power cord connector **44** at the other end. Connector **44** is configured to be coupled to a connector **46** of air supply apparatus **10**.

[0030] The front and rear case assemblies **22** and **24** are each formed to include an elongated slot **48** and **50**, respectively. Slot **48** is open completely through the first case assembly **22**. Slot **50** terminates in an end wall **52** on rear case assembly **24**. Slots **48** and **50** cooperate to define an article receiving slot for holding articles such as a user manual **54** which can be inserted into slot **58** in the direction of arrow **56** and stored for convenience. User manual **54** provides instructions for operation of the air supply apparatus **10**.

[0031] Referring now to FIG. 3, a battery assembly 58 is located within the housing 12. Air supply apparatus 10 includes a first large hanger assembly 60 coupled to housing 12 and a second smaller hanger assembly 62 which is also coupled to housing 12.

[0032] Large hanger assembly 60 is illustrated in FIG. 4. Hanger assembly 60 includes first and second spaced apart mounting arms 64, each having a hook portion 66 for coupling the housing to a footboard 82 of a bed (not shown) as discussed below. Hooks 66 are covered by a protective coating. Large hanger assembly 60 also includes a cross bar 68 coupled to arms 64. Cross bar 68 is formed to include two notched portions 70. Arms 64 are each formed to include an aperture 72 configured to receive a pin 74 to couple the arms 64 to hanger brackets 76. Pins 74 extend through apertures 75 formed in spaced apart flanges 77 of brackets 76. Hanger brackets 76 include a first pair of apertures 78 to permit the hanger assembly 60 to be coupled to the housing 12 with suitable fasteners 80 shown in FIGS. 3 and 6. It is understood that four such fasteners 80 are used to couple the hanger assembly 60 to the housing 12.

[0033] Large hanger assembly 60 is movable from an upwardly extending pivoted position shown in FIGS. 2 and 6 for mounting the housing 12 on a footboard 82 of a bed (not shown). When in the upwardly pivoted position shown in FIGS. 2 and 6, the large hanger assembly 60 is positioned so that hooks 66 extend over and engage a top end edge 84 of footboard 82. Larger hanger assembly 60 is particularly useful in footboards which include control panels 86 built into the footboard 82 for controlling functions of the bed. Footboard 82 may also include a flip panel 88 which provides access to further control functions. Since the arms 64 are spaced apart by a relatively wide distance, the caregiver can still operate the controls 86 or the controls under flip panel 88 while the housing 12 is mounted on the footboard 82. When not in use, the large hanger assembly 60 is pivoted downwardly relative to housing 12 to the storage position shown in FIG. 7. In this storage position, the arms 64 and hooks 66 are stored within recesses 90 formed on opposite sides of the housing 12 so that the entire hanger assembly 60 is located inwardly from a rear wall 92 of housing 12.

[0034] Small hanger assembly 62 is best illustrated in FIG. 5. Hanger assembly 62 includes opposite support arms 94 which are each formed to include an aperture 96 configured to receive a pin 98 for coupling the hanger 62 to mounting brackets 100. Specifically, pins 98 extend through apertures 102 formed in spaced apart flanges 104 of the mounting brackets 100. Hanger assembly 62 also includes a U-shaped section 106 which is illustratively covered by a protective coating to prevent marring of the footboard 82. Mounting brackets 100 are configured to be coupled to housing 12 by fasteners 108 as best shown in FIG. 6.

[0035] Small hanger assembly 62 is movable from a downwardly pivoted, storage position shown in FIG. 6 in which the arms 94 and the U-shaped portion 106 are located within a recess 110 of housing 12 so that the entire hanger assembly 62 is located inwardly from the rear wall 92 of housing 12. Hanger 62 is also movable to an upwardly pivoted orientation shown in FIG. 7 to couple the housing 12 to the top end 84 of footboard 82 in a second orientation. In the mounting position shown in FIG. 7, the support arms

94 of hanger 62 engage notched portions 70 formed in crossbar 68 of hanger assembly 60 as best shown in FIG. 8. Therefore, crossbar 68 prevents the small hanger assembly 62 from pivoting further upwardly in the direction of arrow 110 in FIG. 7 to hold the housing 12 on the footboard 82.

[0036] As shown in FIG. 9, the air supply apparatus 10 includes a controller such as a microprocessor 112 coupled to the touch screen control panel 16 and to the fluid supply 114 such as a blower motor, compressor, etc. As discussed above, fluid supply 114 is coupled to the therapy device 18 by tube 20. Processor 112 is also coupled to the therapy device 18 by electrical wire 116 to provide electrical control signals to therapy device 18 and to receive signals from the therapy device 18, if applicable.

[0037] A memory 118 is also coupled to the processor 112 within the housing 12. Processor 112 is configured to provide a menu driven display on touch screen 16 to permit a caregiver to provide various therapies to a patient on the therapy device 18. For instance, for the mattress 18, rotation, percussion, vibration, or combinations of these therapies may be provided. In addition, various pressure settings may be provided for air bladders within the mattress 18 to reduce pressure on the patient.

[0038] Processor 112 stores each screen press made by an operator on the control panel 16 in a history buffer of memory 118. Therefore, all key presses entered on touch screen control panel 16 are stored within the memory 118. Air supply apparatus 10 includes a communication port 120 coupled to housing 12 to permit the housing 12 to be coupled directly to a printer or computer 122. Illustratively, port 120 is a serial port coupled to housing 12 and processor 112. Therefore, information related to the therapies provided to the patient or all the inputs entered by the operator can be downloaded to the printer or computer 122. In addition, menus, therapies, or other information can be loaded into the processor 112 from the computer 122. It is understood that the computer 122 could be on site or at a remote location connected via a computer network or telephone line. Therefore, operation of the air supply apparatus 10 can be monitored or controlled from a remote location, if desired.

[0039] Although the invention has been described in detail with reference to a certain illustrated embodiment, variations and modifications exist within the scope and spirit of the present invention as described and defined in the following claims.

1. A fluid supply apparatus for supplying fluid to a therapy device on a bed having a barrier, the apparatus comprising:
 - a housing;
 - a fluid supply located within the housing;
 - a first hanger coupled to the housing, the first hanger being configured to couple the housing to the barrier in a first orientation; and
 - a second hanger coupled to the housing, the second hanger being configured to couple the housing to the barrier in a second orientation.
2. The apparatus of claim 1, wherein the first and second hangers are pivotably coupled to a rear wall of the housing.
3. The apparatus of claim 2, wherein the housing is formed to include first and second recessed portions adjacent

the rear wall configured to receive the first and second hangers, respectively, in downwardly pivoted, storage positions.

4. The apparatus of claim 3, wherein the first and second hangers are located inwardly from the rear wall of the housing when the first and second hangers are in the storage positions.

5. The apparatus of claim 1, wherein the first hanger includes first and second spaced apart arms pivotably coupled to the housing, the first and second arms each including a hook portion configured to engage a top edge of the barrier to couple the housing to the barrier.

6. The apparatus of claim 5, further comprising a cross bar coupled between the first and second arms of the first hanger.

7. The apparatus of claim 6, wherein the cross bar is formed to include notched portions configured to engage the second hanger when the second hanger is in an outwardly pivoted position relative to the housing to hold the second hanger in a position to engage the barrier.

8. The apparatus of claim 1, wherein the second hanger includes first and second arms pivotably coupled to the housing and a U-shaped portion coupled between the first and second arms to define a hook configured to engage a top edge of the barrier.

9. The apparatus of claim 8, further comprising a protective coating located over the U-shaped portion of the second hanger.

10. The apparatus of claim 1, wherein the first hanger includes first and second spaced apart arms pivotably coupled to the housing and the second hanger assembly includes third and fourth spaced apart arms pivotably coupled to the housing.

11. The apparatus of claim 10, wherein the first and second arms have a length greater than the third and fourth arms.

12. The apparatus of claim 11, wherein the first and second arms are spaced apart further than the third and fourth arms.

13. The apparatus of claim 1, wherein the first and second hangers are each pivotable relative to the housing from an upwardly pivoted mounting position to a downwardly pivoted storage position, the first hanger including a cross bar configured to block pivotable movement of the second hanger beyond the cross bar when the first hanger is in the downwardly pivoted storage position.

14. The apparatus of claim 1, further comprising a processor located within the housing, the processor being configured to be electrically coupled to the therapy device, and a touch screen control panel coupled to the housing, the touch screen control panel being electrically coupled to the processor to receive operator inputs to control the therapy device.

15. The apparatus of claim 14, further comprising a communication port coupled to the housing and to the

processor, the communication port being configured permit the processor to upload information related to the therapy device to the processor.

16. The apparatus of claim 1, wherein housing is formed to include an elongated slot configured to define a storage receptacle.

17. The apparatus of claim 16, further comprising a user manual configured to be inserted into the storage receptacle.

18. The apparatus of claim 16, wherein the slot is formed adjacent a bottom end of the housing below the fluid supply.

19. The apparatus of claim 1, further comprising a processor located within the housing and a communication port coupled to the housing, the communication port being coupled to the processor and configured to be coupled to a computer to download information to the computer.

20. The apparatus of claim 1, wherein the therapy device is a mattress and the barrier has a top edge located above the mattress.

21. The apparatus of claim 1, wherein the barrier is a footboard of the bed.

22. A fluid supply apparatus for supplying fluid to a therapy device on a bed having a mattress and a barrier having a top edge located above the mattress, the apparatus comprising:

a housing;

a fluid supply located within the housing;

means for coupling the housing to the barrier in a first orientation; and

means for coupling the housing to the barrier in a second orientation different from the first orientation.

23. The apparatus of claim 22, further comprising a processor located within the housing, the processor being configured to be electrically coupled to the therapy device, and a touch screen control panel coupled to the housing, the touch screen control panel being electrically coupled to the processor to receive operator inputs to control the therapy device.

24. The apparatus of claim 23, further comprising a communication port to the housing and to the processor, the communication port being configured to be coupled to a computer to permit the processor to upload information related to the therapy device to the processor.

25. The apparatus of claim 22, further comprising a processor located within the housing and a communication port coupled to the housing, the communication port being coupled to the processor and configured to be coupled to a computer to download information from the computer.

26. The apparatus of claim 22, wherein the therapy device is the mattress.

27. The apparatus of claim 22, wherein the barrier is a footboard of the bed.

* * * * *