



(19) **United States**

(12) **Patent Application Publication**
McLean et al.

(10) **Pub. No.: US 2011/0112540 A1**

(43) **Pub. Date: May 12, 2011**

(54) **FEMORAL REAMING SYSTEM AND METHOD OF PERFORMING TRIAL REDUCTION**

Related U.S. Application Data

(60) Provisional application No. 60/781,025, filed on Mar. 10, 2006, provisional application No. 60/826,675, filed on Sep. 22, 2006.

(75) Inventors: **Terry W. McLean**, Cordova, TN (US); **Vincent W. Shotton**, Magnolia, TX (US); **Richard D. Lambert**, Germantown, TN (US); **David C. Kelman**, Collierville, TN (US); **David A. Harwood**, New Brunswick, NJ (US); **Jerry L. Jones**, Memphis, TN (US); **Alisha Bergin**, Southaven, MS (US)

Publication Classification

(51) **Int. Cl.**
A61B 17/16 (2006.01)
(52) **U.S. Cl.** **606/80**
(57) **ABSTRACT**

(73) Assignee: **SMITH & NEPHEW, INC.**,
Memphis, TN (US)

An apparatus (10) for removing bone material comprises a distal cutting instrument (12) and a proximal cutting instrument (14). The distal cutting instrument has at least one first cutting edge (30), a shoulder (20), and a shaft portion (22). The shaft portion (22) has an anti-rotation feature. The at least one first cutting edge (30) removes bone material when moved in a first direction. The proximal cutting instrument (14) is removably attached to the shaft portion (22). The proximal cutting instrument (14) has a first end portion (68) and a second end portion (66). The second end portion (66) contacts the shoulder (20) of the distal reamer (12) when the proximal reamer is mounted to the shaft portion (22). The proximal reamer (14) has at least one second cutting edge (32) and an aperture. The aperture is adapted to receive the anti-rotation feature of the shaft portion (22) of the distal reamer (12). The at least one second cutting edge (32) removes bone material when moved in a second direction.

(21) Appl. No.: **12/282,467**

(22) PCT Filed: **Mar. 10, 2007**

(86) PCT No.: **PCT/US2007/063733**

§ 371 (c)(1),
(2), (4) Date: **Dec. 8, 2010**

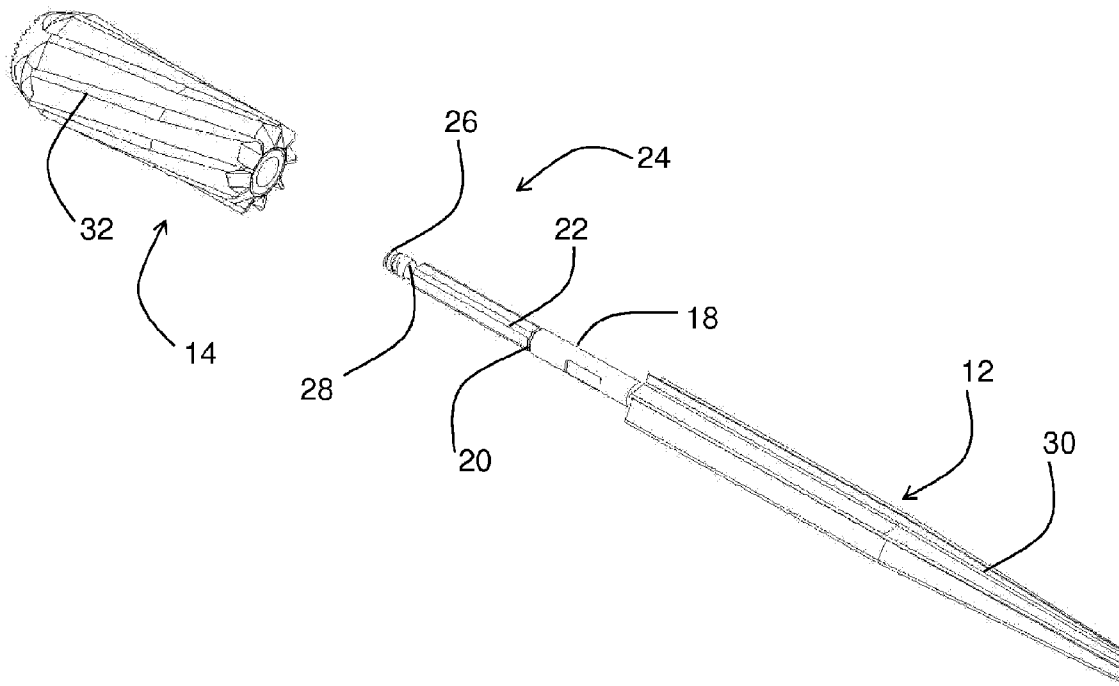

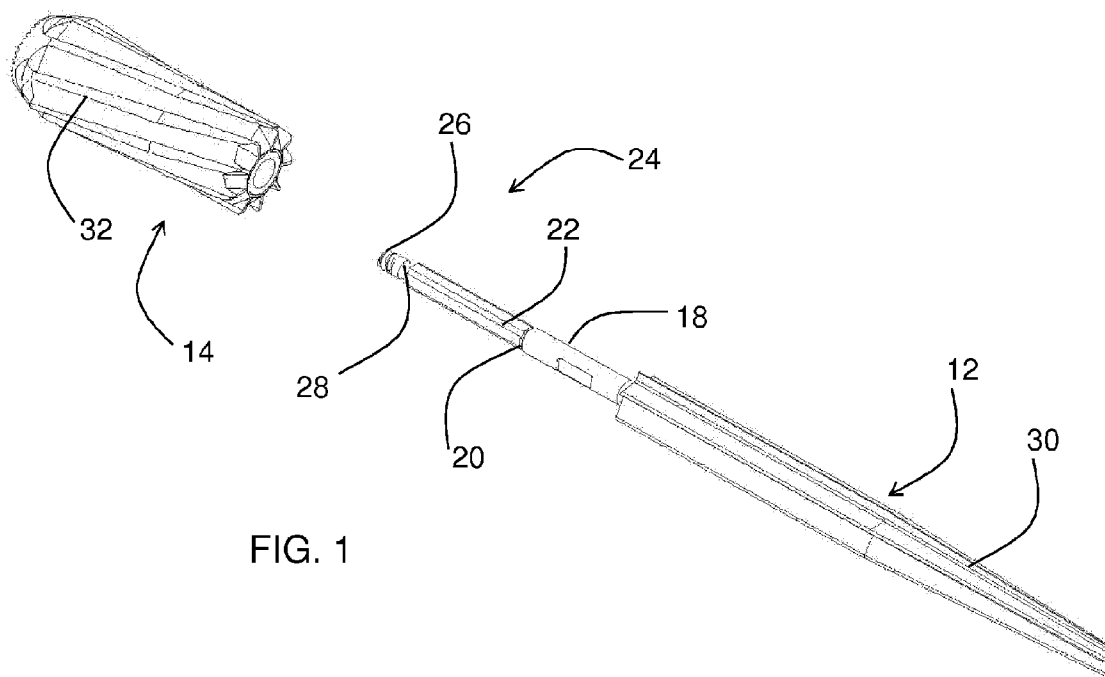

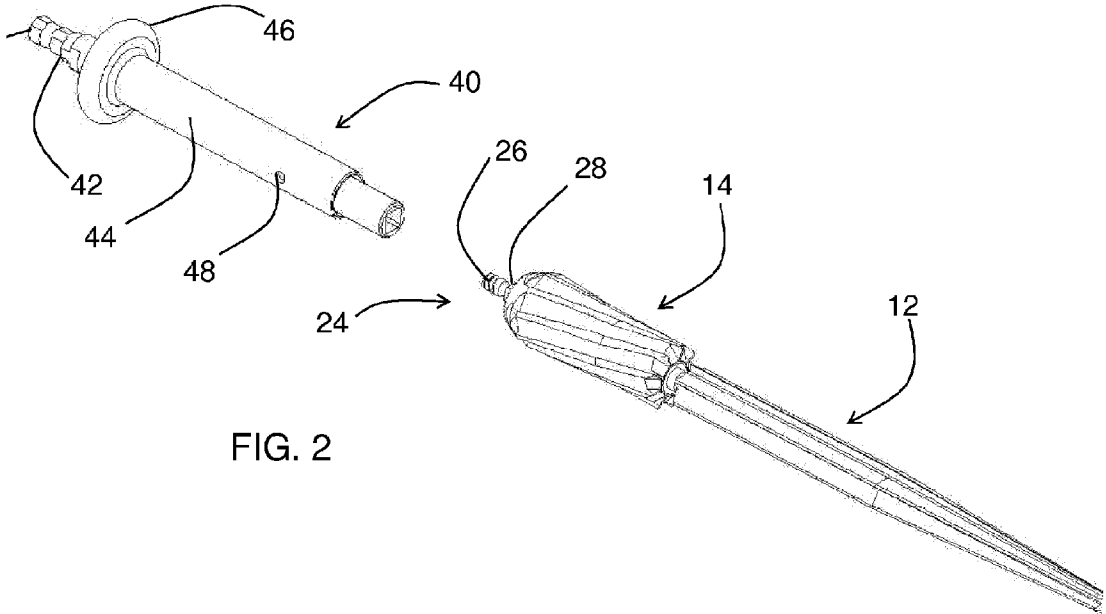
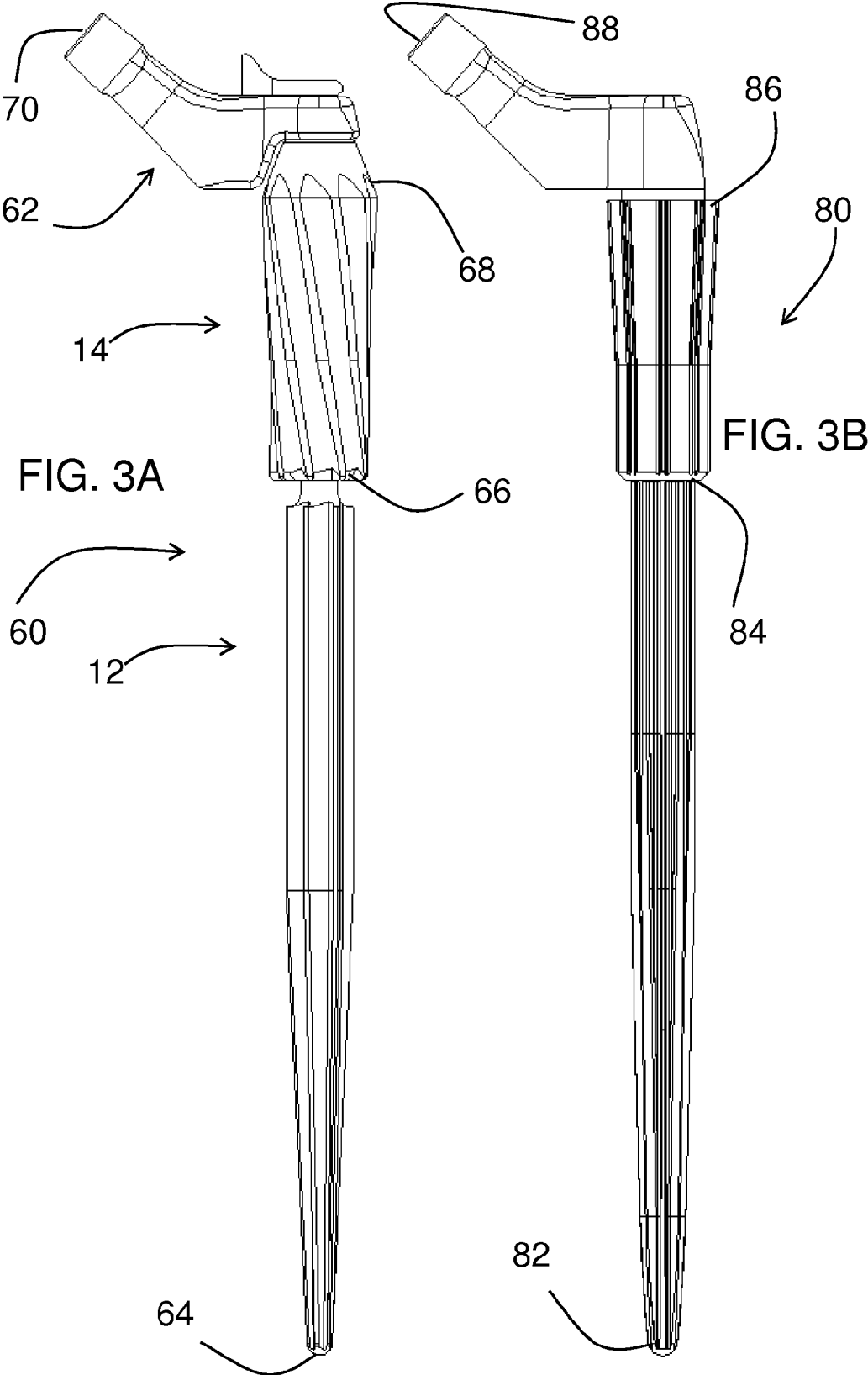

FIG. 2



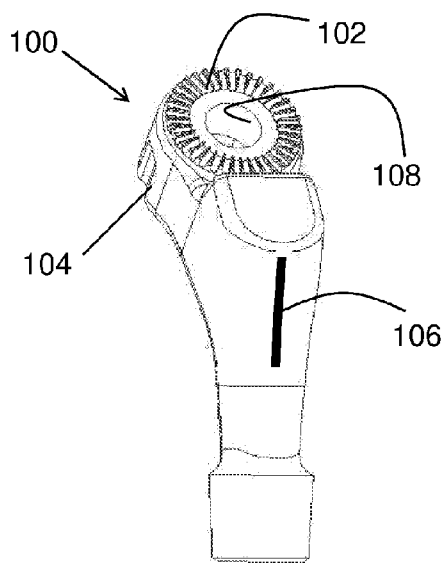

FIG. 4A

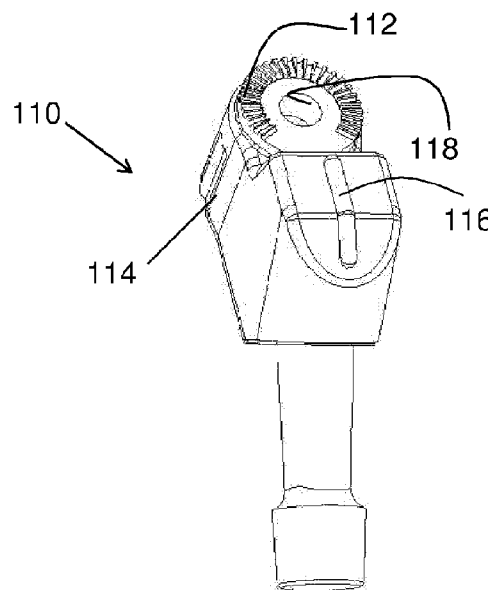

FIG. 4B

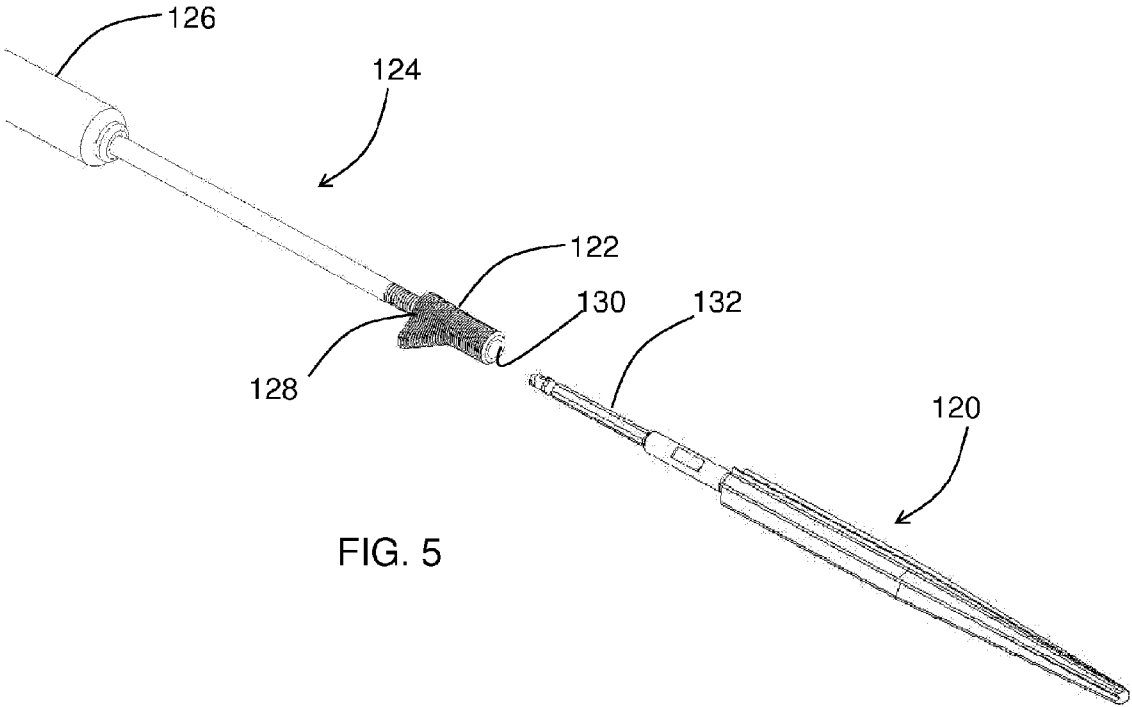

FIG. 5

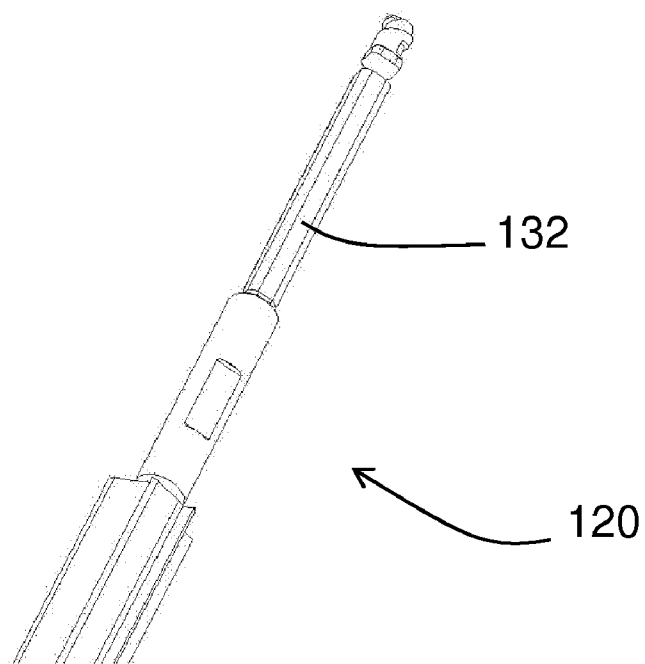
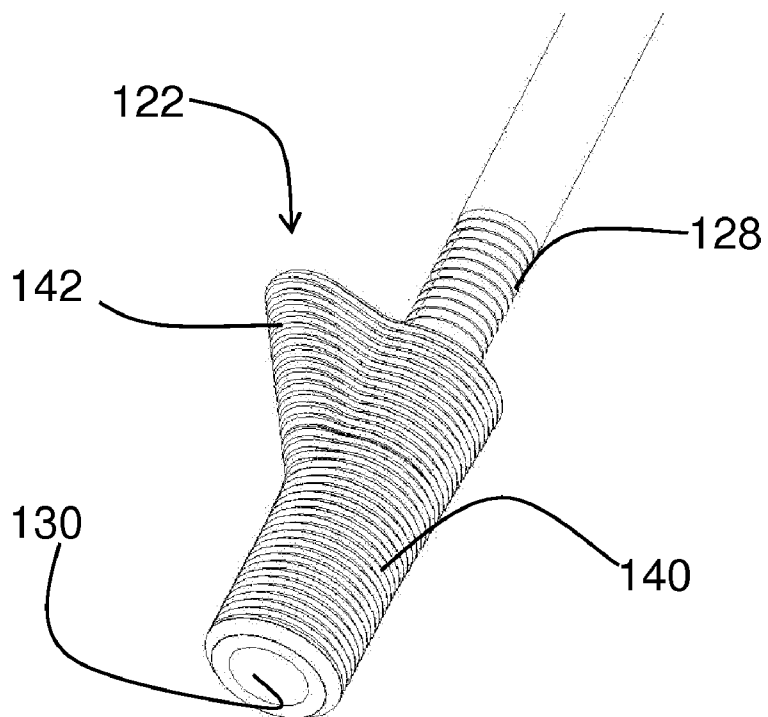

FIG. 6

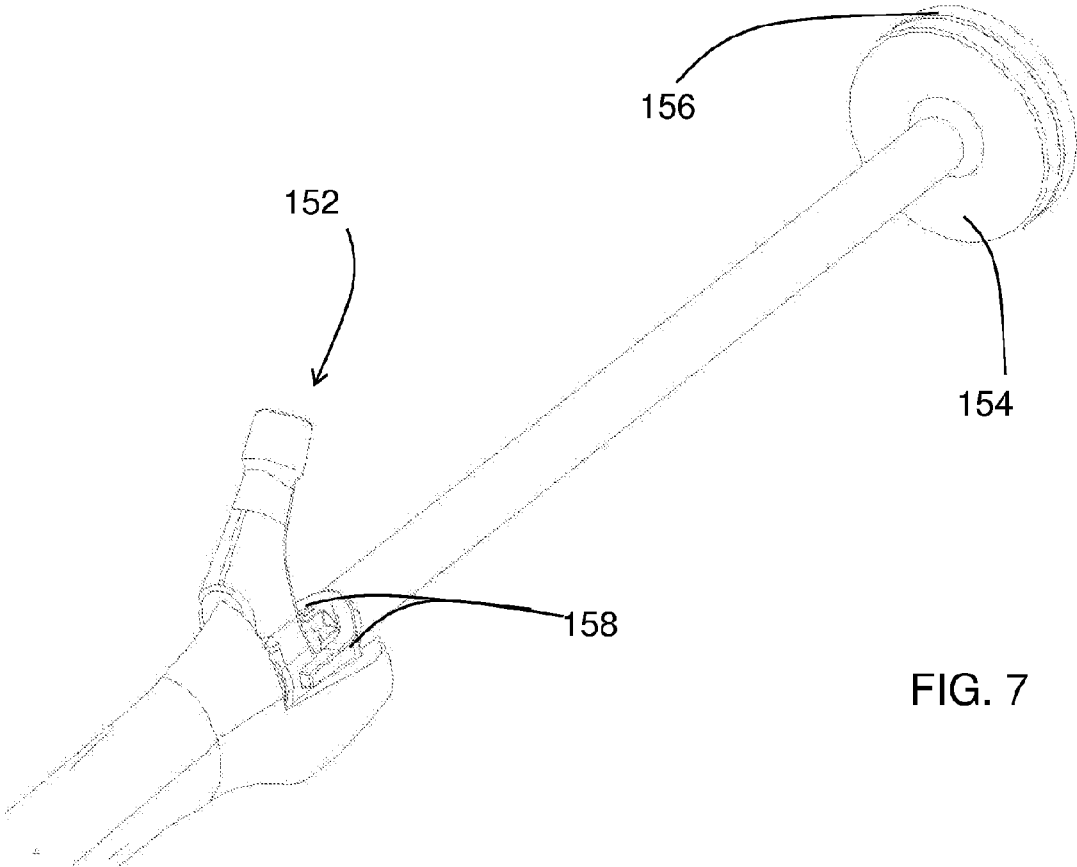

FIG. 7

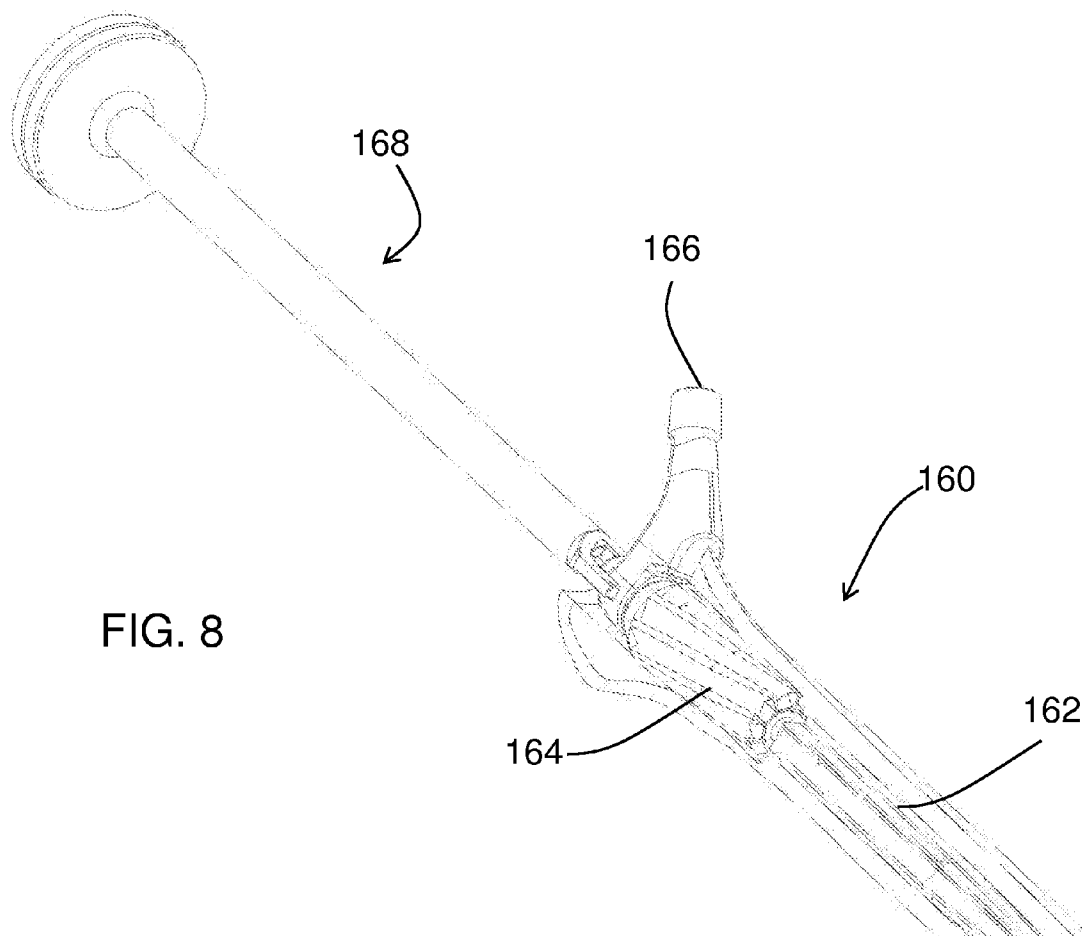

FIG. 8

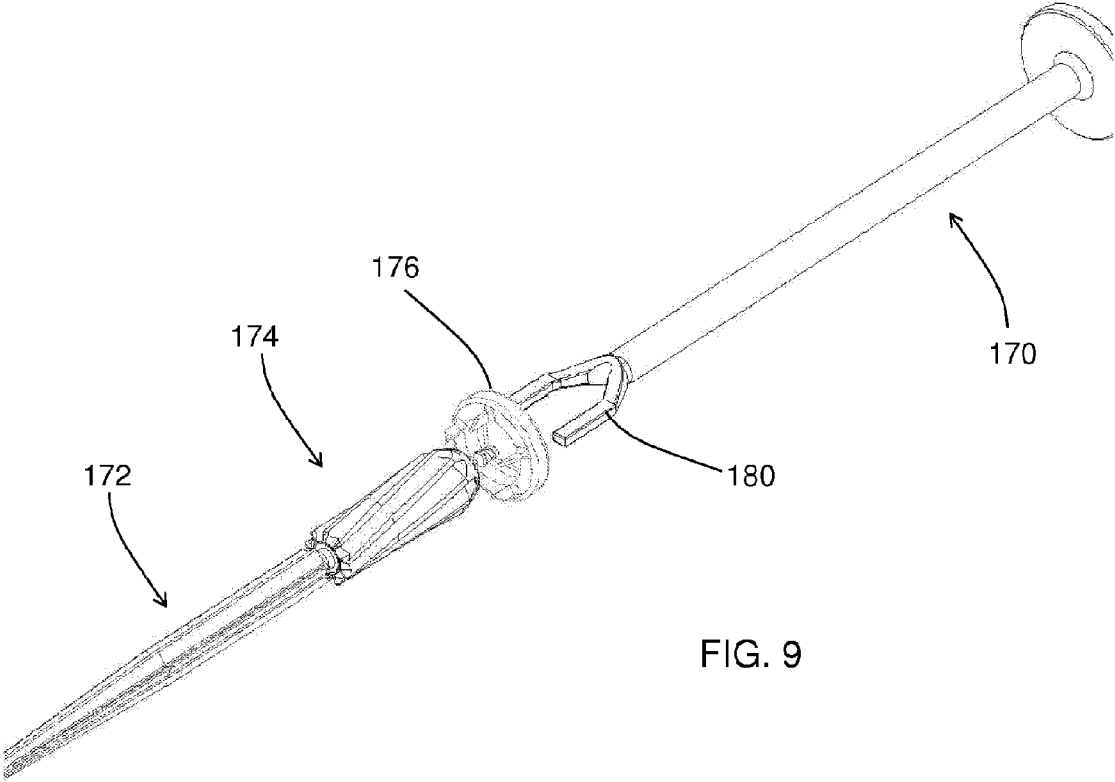
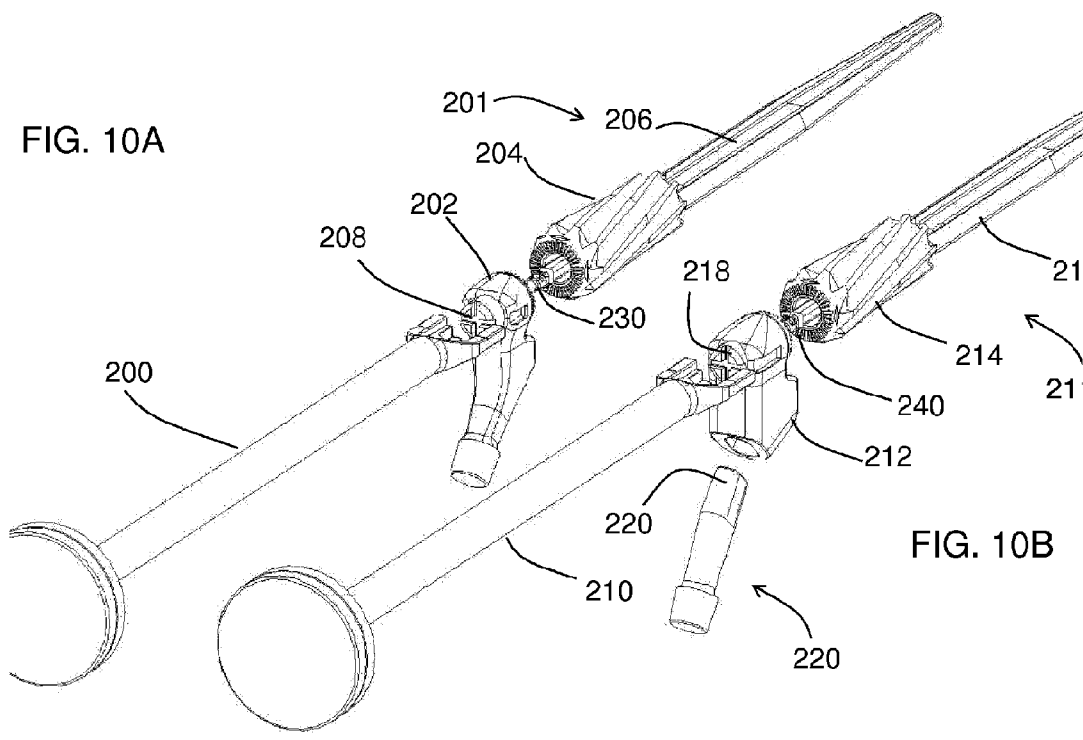

FIG. 9



FEMORAL REAMING SYSTEM AND METHOD OF PERFORMING TRIAL REDUCTION

CROSS-REFERENCE TO RELATED APPLICATIONS

[0001] This application claims the benefit of U.S. Provisional Applications No. 60/826,675, filed Sep. 22, 2006 and No. 60/781,025 filed Mar. 10, 2006. The disclosure of each application is incorporated by reference in its entirety.

STATEMENT REGARDING FEDERALLY SPONSORED RESEARCH OR DEVELOPMENT

[0002] Not Applicable.

APPENDIX

[0003] Not Applicable.

BACKGROUND OF THE INVENTION

[0004] 1. Field of the Invention

[0005] This invention relates generally to surgical devices and, more particularly, to surgical devices used in long bones.

[0006] 2. Related Art

[0007] Current modular implant instrument systems are such that there are two separate reamers provided in preparing the femoral canal. One reamer is used to prepare the distal portion of the canal. The reamer is then removed from the drill and the second reamer is attached to the drill to prepare the proximal portion of the canal. Such systems are labor intensive and time consuming.

[0008] Other systems build on or add to the distal reamers. In these systems, the surgeon would have to build the reamer before attaching to the drill. The surgeon is typically required to ream with the distal reamer until the desired distal diameter is achieved. At this point the surgeon has to remove the distal reamer from the drill and add the proximal reamer/s from the end of the distal reamer shaft. In this system, both the proximal reamer and distal reamer have their own depth marks to reference the greater trochanter. Neither reamer has a common reference mark between the reamers. Therefore, the reamers may still be inexact in preparing the distal to proximal portions of the femoral canal because of errors such as tolerance stack and human error. With the addition of sleeves, another tolerance (sleeve length) must be taken into account when reaming the proximal depth.

[0009] Yet another example uses a combination proximal and distal reamer (or plurality of reamers) having a flexible core within the reamer to allow the proximal portion to flex and prepare the medial side of the metaphyseal within the femur. It can also be utilized to fit more within the bow of the femur. This flexible core can create a series of potential issues. First issue is the ability to clean the tool core. With spiral cuts within the core or other means to create flexibility, the potential exists for blood, tissue, or small bone fragments to be caught within the core of the reamer. Another issue is with the potential of the system binding such that the flexible core creates a "coiling" effect and doesn't allow the reamers to turn and cut due to more torsional resistance of the bone cutting than torsional resistance of the flexible core.

[0010] For a proximal reamer design, the shaft drives both the proximal and distal reamers simultaneously. The elongated shaft guides the proximal broach to remove the medial side of the metaphyseal. Therefore, the purpose of having the

modular proximal reamer is to have exposure for the elongated shaft to use as a guide in broaching.

[0011] In other embodiments, the distal reamer is utilized for reaming out the distal segment only. The surgeon disconnects the distal reamer and connects to a proximal reamer. The proximal reamer requires a distal pilot to be attached, for guiding purposes during the preparation of the metaphyseal for the implant.

[0012] Other reamers have a trial head/neck that can be attached to a reamer or broach for a trial reduction. The head/neck trial assembly is attached by a handle to create the version desired. The head/neck assembly can also be adjusted proximally or distally to select the desired height as well. The location of the head/neck assembly relative to the reamer or broach may be difficult to replicate with the implant. There are no references to locate the head/neck assembly in locating height, thus the implant does not necessarily reflect what the surgeon measured during the trial reduction. The surgeon has to somewhat guess and estimate where the implant will be located and place the head/neck assembly to that location accordingly.

[0013] Other systems with a distal reamer, proximal reamer, and trial neck utilize guide channels on the trial neck adaptor to establish anti-rotation and implant orientation. The proximal reamer is required to have straight flutes in order to have guide channels. The guide channels dictate the cutting geometry that can be utilized for the proximal reamer. This system also does not facilitate the ability for the proximal and distal reamers to be modular such that a surgeon can have various proximal reamers for a given distal reamer.

[0014] There remains a need in the art for increasing accuracy while decreasing the number of steps/instruments that is required of systems that utilize proximal/distal reaming systems. In addition, accuracy and decreasing the number of steps may also be achieved with respect to the method of performing a trial reduction for modular implant designs.

[0015] In addition, orienting the trial neck in situ without having to remove the reamer construct, especially in small incisions, may be beneficial.

SUMMARY OF THE INVENTION

[0016] In one aspect of the invention, an apparatus for removing bone material comprises a distal cutting instrument and a proximal cutting instrument. The distal cutting instrument has at least one first cutting edge, a shoulder, and a shaft portion. The shaft portion has an anti-rotation feature. The at least one first cutting edge removes bone material when moved in a first direction. The proximal cutting instrument is removably attached to the shaft portion. The proximal cutting instrument has a first end portion and a second end portion. The second end portion contacts the shoulder of the distal reamer when the proximal reamer is mounted to the shaft portion. The proximal reamer has at least one second cutting edge and an aperture. The aperture is adapted to receive the anti-rotation feature of the shaft of the distal reamer. The at least one second cutting edge removes bone material when moved in a second direction.

[0017] In another embodiment of the invention, the at least one first cutting edge is a right-hand cutting flute, and the at least one second cutting edge is a left-hand cutting flute.

[0018] In another embodiment of the invention, the apparatus further comprises a quick connect assembly. The quick connect assembly is mountable to the shaft portion and adapted to contact the first end portion.

[0019] In another embodiment of the invention, the quick connect assembly further comprises a depth guide reference.

[0020] In another embodiment of the invention, the apparatus further comprises a trial neck mountable to the shaft portion and adapted to contact the first end portion.

[0021] In another embodiment of the invention, the apparatus further comprises a trial neck mountable to the distal cutting instrument.

[0022] In another embodiment of the invention, the apparatus further comprises a trial neck mountable to the proximal cutting instrument.

[0023] In another embodiment of the invention, the proximal cutting instrument has a slot that extends an entire length of the proximal cutting instrument.

[0024] In another embodiment of the invention, the anti-rotation feature comprises a square cross-section.

[0025] In another embodiment of the invention, the trial neck further comprises a modular portion. The modular portion is configured to be received within the trial neck.

[0026] In another embodiment of the invention, the modular portion is further configured to have a tapered portion. The tapered portion allows for adjustment of the neck axis of the trial neck.

[0027] In another embodiment of the invention, the first cutting instrument comprises a broach.

[0028] In another embodiment of the invention, the apparatus further comprises an insertion tool configured to attach the trial neck to the cutting instruments.

[0029] In another embodiment of the invention, the trial neck and the first end portion of the proximal cutting instrument are further configured having a circumferential pattern of ridges and valleys. The ridges of the pattern on the trial neck are configured to mate to the valleys of the pattern on the first end portion of the proximal cutting surface.

[0030] In another embodiment of the invention, the insertion tool is further configured to rotate the trial neck relative to the distal and proximal cutting instruments.

[0031] In yet another aspect of the invention, a system for performing a trial reduction comprises a combination cutting instrument and a trial neck. The combination cutting instrument comprises a distal cutting instrument and a proximal cutting instrument. The distal reamer has at least one first cutting edge, a shoulder, and a shaft portion. The shaft portion has an anti-rotation feature. The at least one first cutting edge removes bone material when moved in a first direction. The proximal cutting instrument is removably attached to the shaft portion. The proximal cutting instrument has a first end portion and a second end portion. The second end portion contacts the shoulder when the proximal cutting instrument is mounted to the shaft portion. The proximal cutting instrument has at least one second cutting edge and an aperture. The aperture is adapted to receive the anti-rotation feature. The at least one second cutting edge removes bone material when moved in a second direction. The modular trial neck is operatively connected to the combination cutting instrument.

[0032] Another aspect of the invention provides a method for performing a trial reduction comprising providing a combination cutting instrument having a distal cutting instrument and a proximal cutting instrument. The distal reamer has at least one first cutting edge, a shoulder, and a shaft portion. The shaft portion has an anti-rotation feature. The at least one first cutting edge removes bone material when moved in a first direction. The proximal cutting instrument is removably attached to the shaft portion. The proximal cutting instrument

has a first end portion and a second end portion. The second end portion contacts the shoulder when the proximal cutting instrument is mounted to the shaft portion. The proximal cutting instrument has at least one second cutting edge and an aperture. The aperture is adapted to receive the anti-rotation feature. The at least one second cutting edge removes bone material when moved in a second direction. The modular trial neck is operatively connected to the combination cutting instrument. Bone material is removed by moving the combination cutting instruments in the first direction and in the second direction. A modular trial neck is attached to the combination cutting instrument. A trial reduction of the implant is performed.

[0033] In yet another aspect of the invention, a method of preparing a long bone for an implant comprises cutting a distal portion of the long bone by moving a first cutting instrument in a first direction. Another step provides coupling a second cutting instrument to the first cutting instrument. A proximal portion of the long bone is cut by moving the coupled cutting instruments in a second direction different from the first direction such that when the first cutting instrument is moved in the second direction, the first cutting instrument does not cut the distal portion of the long bone.

[0034] Another aspect of the invention provides a method for preparing a trial insert for a long bone. The method comprises preparing a canal in the long bone using at least one cutting instrument. The cutting instrument has the shape of the trial insert. The method also comprises adjusting a trial neck relative to the cutting instrument and coupling the trial neck to the cutting instrument. The trial neck may then be sized relative to the acetabulum for proper version of the trial implant.

[0035] The invention has several advantages over prior devices and techniques. First, the devices may increase accuracy while decreasing the number of steps/instruments that is required of systems that utilize proximal/distal reaming systems. Increased accuracy may reduce the amount of natural bone removed from the femur and may reduce the amount of further preparation after the initial reaming. In addition, reducing the number of steps and instruments may reduce total operation time.

[0036] Second, increased accuracy and decreased number of steps may also be achieved with respect to the method of performing a trial reduction for modular implant designs, at least partially because the trial neck may be oriented in situ without having to remove the reamer construct.

[0037] Further features, aspects, and advantages of the present invention, as well as the structure and operation of various embodiments of the present invention, are described in detail below with reference to the accompanying drawings.

BRIEF DESCRIPTION OF THE DRAWINGS

[0038] The accompanying drawings, which are incorporated in and form a part of the specification, illustrate embodiments of the present invention and together with the description, serve to explain the principles of the invention. In the drawings:

[0039] FIG. 1 is an exploded view of parts of a femoral reamer according to an embodiment of the invention.

[0040] FIG. 2 is an exploded view of the parts of FIG. 1 and a quick connect assembly.

[0041] FIG. 3A is a view of a trial femoral implant including the parts of the femoral reamer of FIG. 1.

[0042] FIG. 3B is a view of a femoral implant.

[0043] FIGS. 4A and 4B are views of trial necks according to an aspect of the invention.

[0044] FIG. 5 is an exploded view of a distal femoral reamer and a proximal broach according to an embodiment of the invention.

[0045] FIG. 6 is a close-up view of the distal femoral reamer and the proximal broach of FIG. 5.

[0046] FIG. 7 is a view of an insertion tool inserting a trial into a femur according to an aspect of the invention.

[0047] FIG. 8 is a cut-away view of the femur of FIG. 7 showing the trial.

[0048] FIG. 9 is a view of an insertion tool according to an aspect of the invention.

[0049] FIGS. 10A and 10B are exploded views of trial inserts and trial insertion tools according to an aspect of the invention.

DETAILED DESCRIPTION OF THE EMBODIMENTS

[0050] Referring to the accompanying drawings in which like reference numbers indicate like elements, FIG. 1 is an exploded view of parts of a femoral reamer 10 according to an embodiment of the invention. The femoral reamer 10 includes two major components, a distal reamer 12 and a proximal reamer 14. The distal reamer 12 prepares the femur for receiving a stem of a femoral implant and the proximal reamer 14 prepares the femur for receiving a sleeve of a femoral implant. The distal reamer 12 includes a thick depth shaft 18, a shoulder 20, a distal reamer shaft 22 and a quick connect mating portion 24. The quick connect mating portion 24 includes a mounting tip 26 and a groove 28. The quick connect mating portion 24 is attached to a drill.

[0051] The distal reamer 12 includes right-hand cutting flutes 30 while the proximal reamer 14 includes left-handed cutting flutes 32. The right-handed cutting flutes 30 have edges on the flutes that cut in a forward cutting action when the reamer 10 is rotated. The edges of the flutes of the distal reamer 12 cuts bone in preparing the distal aspects of the femur by connecting the reamer 10 at the quick connect mating portion 24 to a drill. The reamer 10 may cut the femur in a clockwise manner. The surgeon will ream up (starting at smaller diameters) to the desired distal diameter based on pre-operative templating. In conjunction, the surgeon will ream to a depth based on the implant size. While this embodiment describes one way in which the distal and proximal reamers may be moved relative to one another, those having ordinary skill in the art understand that other relative motions, such as switching the directions of the flutes 30 and 32 or combining axial motion and rotational motion may be implemented. After preparing the distal femur, the proximal femur may be prepared.

[0052] In order to prepare the proximal portion of the femur, the distal reamer 12 is disconnected from the drill and the proximal reamer 14 is attached to the distal reamer 12. The proximal reamer 14 may be slid onto the shaft 22 of the distal reamer 12. The shaft 22 of the distal reamer 12 may have a square cross-section to engage with a square aperture within the proximal reamer 14. The shaft 22 may transfer torque and rotation from the distal reamer 12 to the proximal reamer 14. The proximal reamer 14 may be advanced on the distal reamer 12 until the proximal reamer 14 rests upon the shoulder 20 of the depth shaft 18. The depth shaft 18 sets the relative depth of the distal reamer 12 to the proximal reamer

14. The depth shaft 18 may be larger in diameter in order to minimize stresses on the distal reamer 12.

[0053] In other embodiments, the cross section of the shaft 22 and the aperture in the proximal reamer 14 may be other shapes which allow the proximal reamer 14 to be coupled to the shaft 22 of the distal reamer 12. The cross-section of the shaft 22 provides for anti-rotation of the proximal reamer 14 relative to the distal reamer 12. When the cross-section is in the shape of a square, then there are four possible rotational orientations of the proximal reamer 14 relative to the distal reamer 12 in which the proximal reamer 14 may be seated on the shaft 22. Other cross-sectional embodiments, such as a hexagon or octagon, would have 6 and 8 possible rotational orientations of the proximal reamer 14 relative to the distal reamer 12, respectively. Other cross-sectional shapes, such as a star shape, may also transfer torque and rotation to the proximal reamer 14.

[0054] The proximal femur is prepared using the proximal reamer 14. The surgeon may ream up (starting at a small diameter proximal reamer 14) the proximal portion of the femur by rotating the drill in a counterclockwise manner. The edges of the flutes 32 of the proximal reamer 14 are left-handed cutting flutes. When the reamer 10 is rotated counterclockwise, the left-handed cutting flutes 32 cut the proximal femur. However, the distal reamer 12, when rotated counterclockwise, does not cut the distal femur because the edges of the right-handed cutting flutes 30 of the distal reamer 12 only cut the distal femur when the reamer 10 is rotated clockwise. When rotated counterclockwise, the distal reamer 12 acts as a guide to prepare the proximal femoral canal minimizing additional bone being removed distally. Pre-operative templating may determine the final proximal reamer diameter. In conjunction, the surgeon will ream to a depth based on the implant size. In addition, the distal reamer 12 may limit the depth of the proximal reamer 14 and act as a guide for the orientation of the proximal reamer 14.

[0055] In another embodiment, the proximal reamer may include a slot that runs through the overall length of the proximal reamer. The slot allows the proximal reamer to be "side-loaded" onto a distal reamer without disconnecting the distal reamer from the drill. In such an embodiment, the proximal reamers contain left-hand cutting flutes so that the drill must be set to reverse in order for the proximal reamer to cut. By using a side loading distal reamer, sizing changes between smaller diameter and larger diameter proximal reamers may also be made without disconnecting the distal reamer from the drill.

[0056] A side loaded proximal reamer may be attached to the distal reamer by two parallel flats on the shaft of the distal reamer. The flats, in combination with the slot of the proximal reamer, allow for the proximal reamer to be indexed and locked in position with the aid of a spring loaded plunger. The spring loaded plunger may overlap a portion of the proximal reamer to form an interference fit between the proximal reamer and distal reamer. While the flats may transfer torque and rotation from the distal reamer to the proximal reamer, an interference fit may hold the proximal reamer in axial alignment with the distal reamer.

[0057] In operation, the combination reamer 10 allows for variable reaming size during distal and proximal femur preparation, according to the size of the implant used in the femur. By maintaining the distal reamer position during proximal reaming, fewer stack errors from referencing points relative to other points may be achieved. For example, angular offsets

between the proximal and distal portions are minimized, as well as linear offsets such as depth or lateral movement. Any eccentricity between the shape of the reamer and the shape of the relief may be minimized because less jitter may result when only one of the distal or proximal reamers cuts at one time. This may result in less total bone removal by more accurately removing only the bone necessary to remove. In addition, the orientation may allow for better placement of the implant within the femoral canal with more uniform contact between the implant and the natural bone.

[0058] The quick connect mating portion **24** includes the mounting tip **26** and the groove **28**. The groove **28** is an indentation in the shaft **22** and is configured to receive a ball bearing as described in FIG. 2. The mounting tip **26** may have a cross-section similar to the distal reamer shaft **22**, or may have a cross-section smaller than the shaft **22**. However, the cross-section of the mounting tip **26** should be larger than the cross-section of the groove **28**. The mounting tip **26** may be threaded so that a trial implant may be attached to the distal reamer **12**. In other embodiments, the mounting tip may be configured with other fasteners for attaching the distal reamer **12** to the trial implant.

[0059] Turning now to FIG. 2, FIG. 2 is an exploded view of the parts of FIG. 1 and a quick connect assembly **40**. The quick connect assembly **40** includes an inner cylinder **42**, an outer cylinder **44**, a flange **46**, a transverse pin **48** and a drill connector **50**. The inner cylinder **42** is axially slidable within the outer cylinder **44**, and is biased at the transverse pin **48**. The transverse pin **48** is fixed axially to the outer cylinder **42** and extends through the outer and inner cylinders **42** and **44**. The pin extends through the inner cylinder **42** within a slot. The slot also houses a spring which biases the drill connector **50** of the inner cylinder **42** axially away from the flange **46**.

[0060] When the inner cylinder **42** is axially slid within the outer cylinder **44** (i.e., the drill connection **50** is depressed toward the flange **46**), a pair of bearings are slid out of the bottom of the quick connect assembly **40**. The bearings extend radially outward from the quick connect assembly **40** to a distance greater than the inner diameter of the outer cylinder **44**. With the bearings extending out from the inner cylinder **42**, the quick connect assembly **40** is positioned to connect to the reamers **12** and **14**.

[0061] The proximal reamer **14** is seated on the distal reamer **12**. When the proximal reamer **14** is seated on the distal reamer **12**, the mounting tip **26** and the groove **28** are located above the proximal reamer **14**. Thus, the mating portion **24** of the distal reamer **12** is positioned for attachment to the quick connect assembly **40**. The quick connect assembly **40** is slid over the mounting tip **26** and the groove **28**. The bearings, extended outward, are slid over the groove **28**. The drill connection **50** of the inner cylinder **42**, then, may be axially slid away from the flange **46** and the bearings forced into the groove **28** by the inner surface of the outer cylinder **44**. The inner cross-section of the inner cylinder **42** may be shaped like the cross-section of the distal reamer shaft **22** so that the torque and rotation from the drill may be transferred from the quick connect assembly **40** to the reamers **12** and **14**.

[0062] When the quick connect assembly **40** is attached to the reamers **12** and **14**, the depth of the distal reamer **12** is fixed relative to the quick connect assembly **40**. The quick connect assembly **40** may secure a tight axial fit of the proximal reamer **14** between the quick connect assembly **40** and the distal reamer **12**. In addition, whether the proximal reamer **14** is attached to the distal reamer **12** does not change the

depth of the distal reamer **12**. Because the distance is fixed, the quick connect assembly **40**, then, may also have indicator lines for each implant size on the quick connect assembly **40**. These indicator lines may reference the tip of the greater trochanter, and may be etched into the visible portions of the inner or outer cylinders **42** and **44**. Thus, the quick connect assembly **40** may act as a single reference guide for both the distal reamer **12** and the proximal reamer **14**.

[0063] Turning now to FIG. 3A, FIG. 3A is a view of a trial femoral implant **60** including parts of the femoral reamer of FIG. 1. The trial implant **60** includes the distal reamer **12**, the proximal reamer **14** and a trial neck **62**. The trial neck **62** is oriented relative to the reamers **12** and **14** similar to the orientation of the neck of an implant. When attached to the reamers **12** and **14**, the trial neck **62** acts as an implant for correctly positioning the femoral component relative to the acetabular component of the implant.

[0064] After proximal and distal reaming is complete, the quick connect assembly is detached from the shaft of the distal reamer **12**. The proximal and distal reamers are still located within the femoral canal. The trial neck **62** is then connected to the shaft of the distal reamer **12**, to the proximal reamer **14**, or any combination of the two. The trial neck **62** may be angularly oriented about the axis of the femur, thus providing the surgeon with the desired version angle for the implant prosthesis. The surgeon may then perform a trial reduction of the implant by using the proximal and distal reamers **14** and **12** in conjunction with attaching a trial head to the trial neck **62**.

[0065] The trial neck **62** may be attached to the distal reamer **12** at the mounting tip. For example, a threaded connector may be used through an aperture, as shown in FIGS. 4A and 4B of the trial neck **62**, to fix the trial neck **62** to the reamers **12** and **14**. When the trial neck **62** is attached, the distance from a tip **64** of the distal reamer **12** to the trial neck **62** is fixed. Similarly, a shoulder **66** and upper flared portion **68** of the proximal reamer **14** as well as a head **70** of the trial neck **62** are also fixed in orientation and position relative to one another. These positions and orientations also match the positions and orientations of an implant, as shown in FIG. 3B.

[0066] Turning now to FIG. 3B, FIG. 3B is a view of a femoral implant **80**. A distal tip **82** of the femoral implant **80**, a distal shoulder **84**, a flared proximal shoulder **86**, and a neck head **88** partially define the geometry of the implant **80**. The geometry of the implant **80** is approximated by the trial **62** of FIG. 3A. The proximal reamer **12** reams to a depth equivalent to the depth of the tip **82** of the implant **80**. The proximal reamer **14** approximates the shape of the implant **80** between the distal and proximal shoulders **84** and **86**. The fixed head **88** of the implant **80** is approximated by the trial head **70**. As discussed below, the ability to orient and size the trial head **70** allows for proper implantation of the implant **80**.

[0067] Turning now to FIGS. 4A and 4B, FIGS. 4A and 4B are views of trial necks **100** and **110** according to an aspect of the invention. The trial necks **100** and **110** include a poker chip mating surface **102** and **112**, recessed portions **104** and **114**, and cavities **108** and **118**. The trial neck **100** of FIG. 4A includes an alignment guide **106**, and the trial neck **110** of FIG. 4B includes a fin **116**.

[0068] The poker chip mating surfaces **102** and **112** are adjustable in rotational orientation relative to the reamers. The mating surfaces **102** and **112** are formed such that when the surfaces **102** and **112** are mated to like surfaces on a reamer or other part of the trial implant, the ridges on the trial

necks **100** and **110** are seated within the valleys of the like surfaces on the reamer. Similarly, the valleys on the trial necks **100** and **110** are seated within the ridges of the like surfaces on the reamer. The trial neck, **100** or **110**, then, may be rotated about a general central axis of the reamers. The patterns of the poker chip surface **102** and **112** may be any general surface that allows for a plurality of positions in which to fix the trial neck **100** or **110** to the reamers. In addition, the pattern does not have to be complete around the cavities **108** and **118**.

[0069] The cavities **108** and **118** are configured to receive a connector in order to compress the trial necks **100** and **112** to the reamers, respectively. A connector, such as a T-nut, may be used to fix the trial necks **100** and **110** to the threaded connector of the distal reamer. The trial neck, then, is screwed in place between the connector and the reamer. Thus, when connected by a connector, the trial neck **100** or **110** may be fixed in place for trial reduction. The orientation of the trial neck **100** or **110** may be adjusted by using a tool mated to the recesses **104** and **114** to rotate the trial head **100** and **110**.

[0070] The recesses **104** and **114** may be similar to a spanner head of a screw. The recesses **104** and **114** receive prongs from a tool (shown in FIGS. 7-10) which may provide rotation to the trial head. By placing the recesses **104** and **114** on the periphery of the trial necks **100** and **110**, minimal torque may be used to rotate the trial neck. In addition, the peripheral placement of the recesses **104** and **114** may minimize interference with the connector used through the cavities **108** and **118** to fix the trial necks **100** and **110** to the reamers. While the spanner head-like design of the recesses **104** and **114** have been used in this example, other interfaces designed to transfer rotation and torque from a tool to the trial head **100** or **110** may be used.

[0071] The trial necks **100** and **110** may also have certain features that help orient the neck relative to the bony anatomy. Features such as the groove **106** or fin **116** may be used as a guide to cauterize or draw reference marks on the anatomical structures or natural features to reference the position of the trial neck **100** or **110** relative to other anatomical landmarks or structures.

[0072] Rotation of the trial neck **100** or **110** may be limited by an anti-rotational element to prevent rotation of the trial neck with respect to the bone. The element may be a fin such as the fin **116**, spike, screw, or other structure or method that engages the bone to prevent rotation of the trial neck **100** or **110**. Likewise, the proximal and distal reamers may have structures or methods to prevent rotation of the trial implant relative to the bone. This may be accomplished by, for example, a collar fitted over the reamers to prevent rotation, screws projecting into the bone, grooves that accept pins or screws placed between the trial implant and the bone, or any other structure or method to prevent rotation. The methods and structures that provide rotational alignment of the reamer may also be used as a way to match the alignment of the implant to the trial and associated reamers.

[0073] Turning now to FIG. 5, FIG. 5 is an exploded view of a distal femoral reamer **120** and a proximal broach **122** according to an embodiment of the invention. The broach **122** is configured to connect to an impactor tool **124**, which includes a handle **126** and a connector **128**. The broach **122** and the tool **124** have a cavity **130** configured to receive a shaft **132** of the distal reamer **120**. The shaft **132** aligns the proximal cutting instrument **122** along the axis of the distal reamer **120**. The handle **126** allows a surgeon to manipulate the broach **122** from the end of the tool **124**. The connector

128, in this embodiment a threaded portion of the tool **124**, is configured to receive the broach **122**, or other cutting instrument. Because the broach **122** is not integral to the tool **124**, the size of the broach **122** may be changed according to the needed relief for the implant.

[0074] The cutting instruments (the distal reamer **120** and the broach **122**, in this embodiment) provide another method of preparing a portion of the bone. Other cutting instruments such as rasps or files may be used to remove bone so that the shape in relief approximates the shape of an implant. The cutting instruments may use the distal cutting instrument (in this example, the distal reamer) as a guide. The cutting instruments may prepare any number of geometries either symmetrical or asymmetrical. The instrument may have any number asymmetrical features such as spouts, fins, or bodies.

[0075] Turning now to FIG. 6, FIG. 6 is a close-up view of the distal femoral reamer **120** and the proximal broach **122** of FIG. 5. As described previously, the shaft **132** of the distal reamer **120** is received within the cavity **130** to guide the broach **122** along the axis of the distal reamer **120**. The threaded portion **128** of the tool connects the tool to the broach **122**. Cutting edges **140** of the broach **122** cut the proximal bone when the broach **122** is moved axially along the shaft **132**. The cross-section of the shaft **132**, which in this embodiment is square, keeps the broach **122** from rotating. Rotation would cause an asymmetrical section **142** to rotate and remove more bone than desired.

[0076] The cutting edges **140** of the broach **122** may be circumferential edges separated axially along the axis of the broach **122**. The cutting edges **140** may also extend around the asymmetrical portion **142** of the broach **122** to allow for cutting an asymmetrical relief into the bone. While the cutting edges of the broach **122** in this embodiment are circular, other patterns for the cutting edges, such as spiral edges, may be used on the broach **122**.

[0077] Turning now to FIG. 7, FIG. 7 is a view of an insertion tool **150** inserting a trial **152** into a femur according to an aspect of the invention. The insertion tool **150** includes an outer member **154** and an inner member **156**. The outer member **154** includes prongs **158** configured to rotate the trial. The tool **150** may reference the position or version of the trial neck to the bone with the position and orientation of the prongs **158**. Features may reference certain anatomical landmarks or prepositioned landmarks such as cautery marks or pin anchors, or to instruments either part of the construct or in the surgical field.

[0078] The inner member **156** includes a portion configured to fix the trial **152** to the reamers. The portion of the inner member **156** may include a driver head configured to interface with a screw head on the trial **152**. As previously described, the screw head would connect to the mounting tip of the distal reamer through the cavity in the trial neck to fix the trial neck **152** to the reamer.

[0079] The prongs **158** of the outer member **154** attach to the recesses on the trial head to rotate the trial neck **152** within the femoral canal. In order to adjust the trial neck **152**, the tool **150** is used to release the trial neck connection from the reamer. The tool **150** may hold, reposition, and reconnect the trial neck **152**. Likewise the tool **150** may also introduce or remove the trial neck from the surgical field.

[0080] Turning now to FIG. 8, FIG. 8 is a cut-away view of the femur of FIG. 7 showing the trial. **160**. The trial **160** is axially aligned through the distal reamer **162**, the proximal reamer **164**, the trial neck **166** and the insertion tool **168**. The

relative orientation of the insertion tool **168** to the reamers **162** and **164** sets the version and orientation of the trial neck **166** for the trial **160**. Thus, the trial **160** may be made up of the reamers **162** and **164** and a trial neck **166**, allowing for a modular sizing, versioning, and orienting of the implant by allowing multiple sizes of trial heads and versions of trial heads in a single step.

[0081] Turning now to FIG. 9, FIG. 9 is a view of an insertion tool **170** according to an aspect of the invention. A distal reamer **172**, a proximal reamer **174** and a sleeve impactor ring **176** are aligned with the tool **170**. Prongs **180** impact the impactor ring **176**, which would impact a proximal sleeve. A trial neck may also be attached to the modular implant sleeve impactor **176**, for example through a quick connect assembly to the sleeve impactor **176**. By disconnecting the impaction portion of the sleeve impactor **176**, the trial neck may be connected. Thus, the surgeon can perform a trial reduction including a proximal sleeve implant.

[0082] Turning now to FIGS. 10A and 10B, FIGS. 10A and 10B are exploded views of trial inserts **201** and **211** and trial insertion tools **200** and **210** according to an embodiment of the invention. The trial inserts include a trial neck **202** and **212**, a proximal reamer **204** and **214**, distal reamer **206** and **216**, and a connector **208** and **218**. The trial **211** also includes a modular member **220** having a tapered portion **222** for insertion into the trial neck **212**. The connectors **208** and **218** fix the trial neck **202** and **212** to the distal reamers **206** and **216** at the mounting tips **230** and **240**.

[0083] In order to fine tune the anatomical fit of an implant, the modular member **220** is mated with the trial neck **218**. The tapered portion **222** may adjust the geometrical length, height or angulation of the neck axis in order to restore the patient's anatomical kinesthetics. The tapered portion **222** may also have features that orient the neck relative to the bony anatomy, as mentioned above. The modular member **220** may be used on either an implant or trial.

[0084] The method of preparing the femoral canal includes attaching a distal cutting instrument to a drill. The cutting instrument is inserted into the IM canal and the distal portion is shaped by moving the distal cutting instrument in a first direction. When the distal portion is sufficiently shaped, then the drill is disconnected from the distal cutting instrument, and the distal cutting instrument may remain within the IM canal. A proximal cutting instrument is placed onto the distal cutting instrument over the shaft of the distal cutting instrument. The drill is then attached to the cutting instrument. In one embodiment, the drill is attached to the distal cutting instrument through a quick connect assembly. The proximal portion of the canal is shaped, and the canal may then be properly sized for an implant.

[0085] The method of preparing a trial insert includes shaping a distal portion by moving a first cutting instrument in a first direction and a proximal portion of a femur by moving a second cutting instrument in a second direction. A trial neck is attached to one of the cutting instruments. The trial neck is rotationally adjustable relative to the cutting instruments. A head of the trial neck may also be adjustable relative to the trial neck to adjust the version of the trial neck.

[0086] In view of the foregoing, it will be seen that the several advantages of the invention are achieved and attained.

[0087] The embodiments were chosen and described in order to best explain the principles of the invention and its practical application to thereby enable others skilled in the art

to best utilize the invention in various embodiments and with various modifications as are suited to the particular use contemplated.

[0088] As various modifications could be made in the constructions and methods herein described and illustrated without departing from the scope of the invention, it is intended that all matter contained in the foregoing description or shown in the accompanying drawings shall be interpreted as illustrative rather than limiting. Thus, the breadth and scope of the present invention should not be limited by any of the above-described exemplary embodiments, but should be defined only in accordance with the following claims appended hereto and their equivalents.

What is claimed is:

1. A system for removing bone material, the system comprising:
 - a. a distal cutting instrument, the distal cutting instrument having at least one first cutting edge, a shoulder, and a shaft portion, the shaft portion having an anti-rotation feature, and wherein the at least one first cutting edge removes bone material when moved in a first direction; and
 - b. a proximal cutting instrument removably attached to the shaft portion, the proximal cutting instrument having a first end portion and a second end portion, the second end portion contacting the shoulder of the distal reamer when the proximal reamer is mounted to the shaft portion, the proximal reamer having at least one second cutting edge and an aperture, the aperture adapted to receive the anti-rotation feature, and wherein the at least one second cutting edge removes bone material when moved in a second direction.
2. The system of claim 1, wherein the at least one first cutting edge is a right-hand cutting flute, and the at least one second cutting edge is a left-hand cutting flute.
3. The system of claim 1, further comprising a quick connect assembly, the quick connect assembly mountable to the shaft portion and adapted to contact the first end portion.
4. The system of claim 3, wherein the quick connect assembly further comprises a depth guide reference.
5. The system of claim 1, further comprising a trial neck mountable to the shaft portion and adapted to contact the first end portion.
6. The system of claim 1, further comprising a trial neck mountable to the distal cutting instrument.
7. The system of claim 1, further comprising a trial neck mountable to the proximal cutting instrument.
8. The system of claim 1, wherein the proximal cutting instrument has a slot that extends an entire length of the proximal cutting instrument.
9. The system of claim 1, wherein the anti-rotation feature comprises a square cross-section.
10. The system of claim 1, wherein the trial neck further comprises a modular portion, the modular portion configured to be received within the trial neck.
11. The system of claim 1, wherein the modular portion is further configured to have a tapered portion, the tapered portion allowing for adjustment of the neck axis of the trial neck.
12. The system of claim 1, wherein the first cutting instrument comprises a broach.
13. The system of claim 12, further comprising an insertion tool configured to attach the trial neck to the cutting instruments.

14. The system of claim **12**, wherein the trial neck and the first end portion of the proximal cutting instrument are further configured having a circumferential pattern of ridges and valleys such that the ridges of the pattern on the trial neck is configured to mate to the valleys of the pattern on the first end portion of the proximal cutting surface.

15. The system of claim **14**, wherein the insertion tool is further configured to rotate the trial neck relative to the distal and proximal cutting instruments.

16. A method for preparing a femoral canal, comprising the steps of:

- a. moving a first cutting instrument in a first direction thereby cutting a first portion of bone;
- b. attaching a second cutting instrument to the first cutting instrument; and
- c. moving the first and second cutting instruments in a second direction different than the first direction thereby cutting a second portion of bone.

17. The method of claim **16**, wherein the first and second directions are clockwise and counterclockwise rotation.

18. The method of claim **16**, wherein the first and second cutting instruments do not cut the first portion of bone when the first and second cutting instruments are moved in the second direction.

19. The method of claim **16**, further comprising the step of attaching a trial instrument to at least one of the first and second cutting instruments.

20. The method of claim **19**, further comprising the steps of:

- rotating the trialing instrument relative to at least one of the first and second cutting instruments; and
- fixing the trialing instrument to at least one of the first and second cutting instruments.

* * * * *