

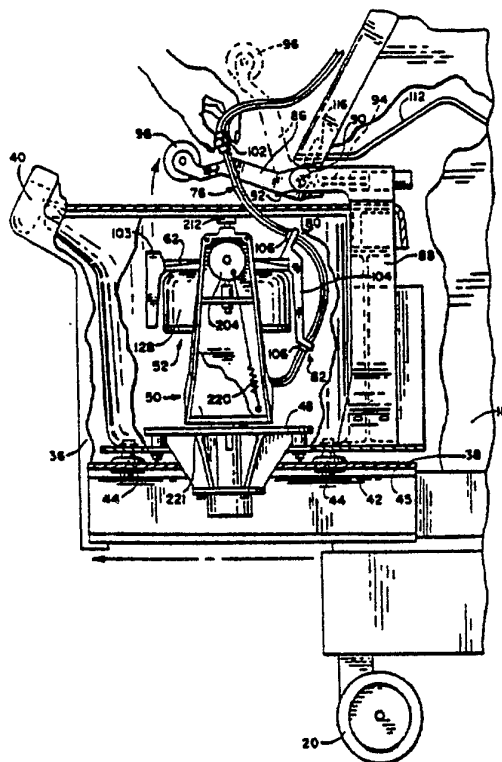

INTERNATIONAL APPLICATION PUBLISHED UNDER THE PATENT COOPERATION TREATY (PCT)

<p>(51) International Patent Classification ⁵ : B04B 5/02, 11/00, 9/00</p>	<p>A1</p>	<p>(11) International Publication Number: WO 93/12887 (43) International Publication Date: 8 July 1993 (08.07.93)</p>
<p>(21) International Application Number: PCT/US92/11216 (22) International Filing Date: 23 December 1992 (23.12.92) (30) Priority data: 7/813,157 23 December 1991 (23.12.91) US (71) Applicant: BAXTER INTERNATIONAL INC. [US/US]; One Baxter Parkway, Deerfield, IL 60015 (US). (72) Inventor: WILLIAMSON, Warren, P., IV ; 8053 Village Drive, Cincinnati, OH 45242 (US). (74) Agents: PRICE, Bradford, R., L. et al.; One Baxter Park- way, Deerfield, IL 60015 (US).</p>		<p>(81) Designated States: AU, CA, JP, European patent (AT, BE, CH, DE, DK, ES, FR, GB, GR, IE, IT, LU, MC, NL, PT, SE). Published <i>With international search report.</i></p>

(54) Title: CENTRIFUGAL PROCESSING SYSTEM WITH DIRECT ACCESS DRAWER



(57) Abstract

A drawer-mounted (36) centrifuge (12) provides easy access for loading and unloading disposable processing elements (22). The centrifuge also includes an umbilicus holder (86) that moves between an operating position and an out-of-way position as the drawer opens and closes.

FOR THE PURPOSES OF INFORMATION ONLY

Codes used to identify States party to the PCT on the front pages of pamphlets publishing international applications under the PCT.

AT	Austria	FR	France	MR	Mauritania
AU	Australia	GA	Gabon	MW	Malawi
BB	Barbados	GB	United Kingdom	NL	Netherlands
BE	Belgium	GN	Guinea	NO	Norway
BF	Burkina Faso	GR	Greece	NZ	New Zealand
BG	Bulgaria	HU	Hungary	PL	Poland
BJ	Benin	IE	Ireland	PT	Portugal
BR	Brazil	IT	Italy	RO	Romania
CA	Canada	JP	Japan	RU	Russian Federation
CF	Central African Republic	KP	Democratic People's Republic of Korea	SD	Sudan
CG	Congo	KR	Republic of Korea	SE	Sweden
CH	Switzerland	KZ	Kazakhstan	SK	Slovak Republic
CI	Côte d'Ivoire	LI	Liechtenstein	SN	Senegal
CM	Cameroon	LK	Sri Lanka	SU	Soviet Union
CS	Czechoslovakia	LU	Luxembourg	TD	Chad
CZ	Czech Republic	MC	Monaco	TG	Togo
DE	Germany	MG	Madagascar	UA	Ukraine
DK	Denmark	ML	Mali	US	United States of America
ES	Spain	MN	Mongolia	VN	Viet Nam
FI	Finland				

**Centrifugal Processing System
With Direct Access Drawer**

5 Field of the Invention

 The invention relates to centrifugal processing systems and apparatus.

Background of the Invention

10 Today people routinely separate whole blood by centrifugation into its various therapeutic components, such as red blood cells, platelets, and plasma.

 Conventional blood processing methods use durable centrifuge equipment in association with single use, sterile processing systems, typically made of plastic. The operator loads the disposable systems upon the centrifuge before processing and removes them afterwards.

15 Conventional centrifuges often do not permit easy access to the areas where the disposable systems reside during use. As a result, loading and unloading operations can be time consuming and tedious.

20 Disposable systems are often preformed into desired shapes to simplify the loading and unloading process. However, this approach is often counterproductive, as it increases the cost of the disposables.

25 Summary of the Invention

 The invention provides improved centrifugal processing systems that provide easy access to the rotating parts of the centrifuge for loading and un-

- 2 -

loading disposable processing components. The invention achieves this objective without complicating or increasing the cost of the disposable components. The invention allows relatively inexpensive and straightforward disposable components to be used.

One aspect of the invention provides a system that includes a centrifuge assembly carried by a frame. The frame encloses an interior area. The centrifuge assembly including a chamber and a mechanism for rotating the chamber about an axis.

According to this aspect of the invention, a base supports the centrifuge assembly on the frame. The base includes a mechanism for moving the base and, with it, the entire centrifuge assembly on the frame. The movable base allows user to locate the entire centrifuge assembly within the interior area of the frame, thereby blocking access to the centrifuge assembly during a processing procedure. The movable base also allows the user to locate the entire centrifuge assembly outside the interior area of the frame, thereby permitting access to the centrifuge assembly at the end of a processing procedure.

This arrangement fully encloses the centrifuge assembly when necessary during processing operations. Still, the centrifuge assembly can be made readily accessible to the user after the processing operations are over. For example, once the centrifuge assembly is located outside the frame, the user can quickly and easily handle the disposable processing elements that must be installed and then removed before and after each processing operation. This eliminates the need for expensive processing elements specially design to be fitted into tight and awkward quarters.

In a preferred embodiment, the base moves in

- 3 -

a direction generally perpendicular to the rotation axis of the chamber in a drawer that can be opened and closed. The drawer carries the centrifuge assembly, allowing the user to locate the centrifuge assembly in its first position when the drawer is closed and to
5 locate the centrifuge assembly in its second position when the drawer is opened.

In a preferred embodiment, force dampening mounts isolate the base from vibration and oscillation caused by the rotating chamber. In this arrangement,
10 the entire isolated mass of the centrifuge assembly is accessible to the user.

Another aspect of the invention provides movable centrifuge assembly as just described having a processing element that is removably insertable into
15 the processing chamber. An umbilicus conveys fluid into the processing element to undergo centrifugal separation during rotation of the chamber.

According to this aspect of the invention, the centrifuge assembly includes a holder that
20 releasably receives the umbilicus. The holder assumes an operating position that orients the umbilicus in a prescribed relationship with the centrifuge assembly during processing operations. The holder also as-
25 sumes a nonoperating position spaced away from the centrifuge assembly that allowing user access to the chamber.

In this arrangement, as the base and, with it, the centrifuge assembly and holder means are moved
30 to the enclosed position within the frame, the holder moves toward its operating position, ready for processing operations. Likewise, as the base moves to its exposed position outside the frame, the holder moves toward its nonoperating position, opening up
35 access to the chamber.

- 4 -

In a preferred embodiment, a locking mechanism retains the holder in its operating position when the base is in its enclosed position. The locking mechanism is freed in response to movement of the base from its enclosed position toward its exposed position.

In a preferred embodiment, the holder, like the centrifuge assembly itself, is carried on the force dampening mounts, thereby forming a part of the isolated mass of the centrifuge.

The features and advantages of the invention will become apparent from the following description, the drawings, and the claims.

Brief Description of the Drawings

Fig. 1 is a side elevation view of a processing system that embodies the features of the invention, with the drawer carrying the rotating components of the centrifuge assembly shown in its open position for loading the associated fluid processing chamber;

Fig. 2 is a front perspective view of the processing system shown in Fig. 1, with the drawer closed as it would be during normal processing operations;

Fig. 3 is an exploded perspective view of the drawer and rotating components of the centrifuge assembly;

Fig. 4 is an enlarged perspective view of the rotating components of the centrifuge assembly shown in its suspended operating position;

Fig. 5 is a side sectional view of the rotating components of the centrifuge assembly taken generally along line 5-5 in Fig. 4;

Fig. 6 is a side elevation view, with portions broken away and in section, of the rotating com-

- 5 -

ponents of the centrifuge assembly housed within the drawer, which is shown closed;

5 Fig. 7 is an enlarged side elevation view of the umbilicus mounts associated with the centrifuge assembly;

Fig. 8 is an enlarged perspective view of the zero omega holder and associated upper umbilicus mount;

10 Fig. 8A is an enlarged perspective view of an alternative embodiment of the zero omega holder, with the associated latch member in its upraised position;

15 Fig. 8B is an enlarged perspective view of the alternative embodiment of the zero omega holder shown in Fig. 8A, with the associated latch member in its lowered position;

Fig. 9 is a top section view of the upper umbilicus block taken generally along line 9-9 in Fig. 7;

20 Fig. 10 is a schematic view of the drive controller for the rotating components of the centrifuge assembly;

25 Fig. 11 is a side elevation view, with portions broken away and in section, of the rotating components of the centrifuge assembly housed within the drawer, which is shown in a partially opened condition;

30 Fig. 12 is a side elevation view, with portions broken away and in section, of the rotating components of the centrifuge assembly housed within the drawer, which is shown in a fully opened condition;

35 Fig. 13 is a side elevation view, with portions broken away and in section, of the rotating components of the centrifuge assembly housed within the drawer, which is shown in a fully opened condition,

- 6 -

with the centrifuge assembly upright and opened for loading and unloading the associated processing chamber;

5 Fig. 14 is a schematic view of the drawer interlocks associated with the centrifuge assembly;

Fig. 15 is an enlarged perspective view of the rotating components of the centrifuge assembly shown in its upraised position for loading and unloading the associated processing chamber;

10 Fig. 16 is a perspective exploded view of the locking pin component of the swinging lock assembly that pivots the rotating components of the centrifuge assembly between operating and upraised positions;

15 Fig. 17 is a perspective exploded view of the entire the swinging lock assembly that pivots the rotating components of the centrifuge assembly between its operating and upraised positions;

20 Figs. 18A; 18B; and 18C are a series of side section views showing the operation of the swinging lock assembly;

25 Fig. 19 is a side sectional view of the rotating components of the centrifuge assembly when in its upraised position, taken generally along line 19-19 in Fig. 15;

Fig. 20 is a side sectional view of the rotating components of the centrifuge assembly when in its upraised and open position;

30 Fig. 21 is an enlarged and exploded perspective view, with portions broken away and in section, of a mechanism for moving and securing the centrifuge assembly in its open and closed positions, as well as clamping the umbilicus near the processing chamber;

35 Fig. 22 is a side section view, taken generally along line 22-22 in Fig. 21, of the latch member

- 7 -

associated with the mechanism shown in Fig. 21;

Figs. 23 and 24 are side section views showing the operation of the latch member associated with the mechanism shown in Fig. 21;

5 Fig. 25 is an enlarged and exploded perspective view, with portions broken away and in section, of an alternative mechanism for moving and securing the centrifuge assembly in its open and closed positions, as well as clamping the umbilicus near the
10 processing chamber;

Figs. 26 and 27 are side sectional views showing the operation of the mechanism shown in Fig. 25;

15 Fig. 28 is a perspective view of the processing chamber as it is being wrapped onto the centrifuge spool prior to use;

Fig. 29 is a perspective view of the processing chamber wrapped on the centrifuge spool for use;

20 Fig. 30 is a perspective view, with portions broken away, of the centrifuge spool holding the processing chamber and in position within the centrifuge bowl for use;

25 Fig. 31 is a top section view, taken generally along line 31-31 of Fig. 30, of the centrifuge spool holding the processing chamber and in position within the centrifuge bowl for use; and

30 Fig. 32 is an exploded perspective view of an interchangeable centrifuge spool assembly on which a processing chamber can be mounted;

Description of the Preferred Embodiments

35 Figs. 1 and 2 show a centrifugal processing system 10 that embodies the features of the invention. The system 10 can be used for processing various fluids. The system 10 is particularly well suited for

- 8 -

processing whole blood and other suspensions of cellular materials that are subject to trauma. Accordingly, the illustrated embodiment shows the system 10 used for this purpose.

5 The system 10 includes a centrifuge assembly 12 and an associated fluid processing assembly 14. The centrifuge assembly 12 is a durable equipment item. The fluid processing assembly 14 is a single use, disposable item that the user loads on the centrifuge assembly 12 before beginning a processing procedure (as Fig. 1 generally shows) and removes from 10 the centrifuge assembly 12 upon the completing the procedure.

 The centrifuge assembly 12 comprises a 15 centrifuge 16 mounted for rotation within a cabinet 18. The user maneuvers and transports the cabinet 18 upon the associated wheels 20. It should be appreciated that, due to its compact form, the centrifuge assembly 12 also could be made as a tabletop unit.

20 As Figs. 1 and 2 show, the cabinet 18 includes a sliding drawer 36 that holds the centrifuge 16. As Fig. 1 shows, the user opens the drawer 36 to enter the centrifuge 16 for inserting and removing the processing chamber 22. As Fig. 2 shows, the user 25 closes the drawer 36 when conducting a processing operation.

 The processing assembly 14 comprises a processing chamber 22 mounted on the centrifuge 16 for rotation (as Fig. 1 shows). An associated fluid circuit 24 conveys fluids to and from the processing 30 chamber 22. The fluid circuit 24 has several fluid containers 26. As Fig. 2 shows, in use, the containers 26 hang from a support pole outside the cabinet 18. The fluid circuit 24 transits several peristaltic pumps 28 and clamps 30 on the face of the cabinet 18. 35

- 9 -

The fluid circuit 24 enters an access opening 100 leading to the processing chamber 22 mounted within the cabinet 18. In the illustrated environment, the fluid circuit 24 preconnects the processing chamber 22 with the containers 26, forming an integral, sterile unit closed to communication with the atmosphere.

The centrifuge assembly 12 includes a processing controller 32, various details of which are shown in Figs. 10 and 14. The processing controller 32 coordinates the operation of the centrifuge 16. The processing controller 32 preferably uses an input/output terminal 34 to receive and display information relating to the processing procedure.

The following sections disclose further details of construction of the centrifuge assembly 12, the processing assembly 14, and processing controller 32.

I. THE CENTRIFUGE ASSEMBLY

A. The One Omega Platform and Two Omega Chamber
As Fig. 3 shows, the centrifuge 16 includes a base 42 that supports a plate 45 mounted upon flexible isolation mounts 44. The flexible mounts 44 structurally isolate the components mounted on the plate 45 from the rest of the centrifuge 16, by dampening vibration and oscillation caused by these plate-mounted components. The components mounted on the plate 45 make up the isolated mass of the centrifuge 16.

A nonrotating outer housing or bucket 46 is mounted on the plate 45. The bucket 46 encloses a stationary platform 48, which in turn supports the rotating components of the centrifuge 16.

As Figs. 4 and 5 show in greater detail, the rotating components include a centrifuge yoke assembly 50 and a centrifuge chamber assembly 52. The yoke

- 10 -

assembly 50 rotates upon the platform 48 on a first drive shaft 54. The chamber assembly 52 rotates on the yoke assembly 50 on a second drive shaft 56. The rotating chamber assembly 52 carries the processing chamber 22.

5

The yoke assembly 50 includes a yoke base 58, a pair of upstanding yoke arms 60, and a yoke cross member 62 mounted between the arms 60. The base 58 is attached to the first drive shaft 54, which spins on a bearing element 64 about the stationary platform 48. A first electric drive 66 rotates the yoke assembly 50 on the first drive shaft 54.

10

The chamber assembly 52 is attached to the second drive shaft 56, which spins on a bearing element 68 in the yoke cross member 62. The second drive shaft 56 and the bearing element 68 spin as a unit on ball bearings 70. A second electric drive 72 rotates the centrifuge chamber assembly 52 on the second drive shaft.

15

The first electric drive 66 and the second electric drive 72 each comprises a permanent magnet, brushless DC motor. As Fig. 5 shows, the stationary platform holds the field coils 74 of the first motor 66, while the yoke base 58 comprises the armature or rotor of the first motor 66. The yoke cross member 62 holds the field coils 74 of the second motor 72, while the chamber assembly 52 comprises the associated armature or rotor.

20

25

In the illustrated and preferred embodiment, the first electric motor 66 spins the yoke assembly 50 at a predetermined speed of rotation (which will be called "one omega"). The second electric motor 72 spins the chamber assembly 52 at the same speed of rotation as the first electric motor 66 in the same direction and about the same axis as the spinning yoke

30

35

- 11 -

assembly 50. As a result, when viewed from a stationary (i.e., non-rotating or "zero omega") position, the chamber assembly 52 spins at twice the rotational speed of the yoke assembly 50 (which will be called "two omega").

B. The Umbilicus Mounts at Zero, One, and Two Omega

As Figs. 6 to 9 show, the fluid circuit 24 joining the processing chamber 22 and the processing containers 26 comprises separate tubes 74 joined to form an umbilicus 76. Fluids pass to and from the processing chamber 22 through these tubes 74.

As Figs. 6 and 7 best show, the centrifuge 16 includes several umbilicus mounts 78, 80, 82, and 84 positioned at spaced apart zero omega, one omega, and two omega positions on the centrifuge 16. The mounts 78, 80, 82, and 84 secure the upper, middle, and lower portions of the umbilicus 76, holding it in an inverted question mark shape during processing operations.

The first umbilicus mount 78 is part of a holder 86 mounted at a zero omega position above and aligned with the rotational axis of the centrifuge 16. The mount 78 holds the upper portion of the umbilicus 76 against rotation at this position.

As Figs. 3 and 6 best show, the zero omega holder 86 includes a support frame 88, which is itself attached to the isolation plate 45. The zero omega holder 86 therefore forms a part of the isolated mass of the centrifuge 16.

A pin 90 attaches one end of the zero omega holder 86 to the support frame 88. The holder 86 pivots on this pin 90 along the rotational axis of centrifuge 16 (as generally shown by arrows in Fig. 3). A spring

- 12 -

92 normally biases the holder 86 away from the rotating components 50 and 52 of the centrifuge 16. A solenoid operated latch pin 94 normally locks the holder 86 in the operating position shown in Fig. 6. It should be appreciated that, alternatively, the holder 86 can be manually locked in the operating position using a conventional over-center toggle mechanism (not shown) or the like.

The zero omega holder 86 has a roller member 96 at its opposite end. The roller member 96 rotates on a shaft 98. The roller member 96 is relieved in its mid-portion (see Fig. 8) to receive the umbilicus 76 as it enters the cabinet 18 through an access opening 100.

As Figs. 7 and 8 best show, the first umbilicus mount 78 is located next to the roller member 96. The mount 78 comprises a channel in the holder 86 that captures an upper block 102 carried by the umbilicus 76. When locked in its operating position (shown in Fig. 6), the zero omega holder 86 applies tension on the umbilicus 76, thereby seating the upper umbilicus block 102 within the mount 78.

In the embodiment illustrated in Figs. 7 to 9, the upper umbilicus block 102 is generally hexagonally shaped. The mount 78 is also configured as a hexagon to mate with the block 102. It should be appreciated that other mating shapes can be used to seat the umbilicus block 102 within the mount 78.

Figs. 8A and 8B show an alternative embodiment for the zero omega holder 86. Like the holder 86 shown in Figs. 7 and 8, the holder 86' is mounted for pivotal movement on a pin 90' to the support frame 88 (not shown in Figs. 8A and 8B). Also like the holder 86 shown in Figs. 7 and 8, the holder 86' has a roller member 96' and an umbilicus mount 78' located next to

- 13 -

it. The functions of these components are as previously described.

Unlike the holder 86' shown in Figs. 7 and 8, the holder 86' includes a mechanism for clamping the upper umbilicus block 102 within the mount 78'. While the mechanism can vary, in the illustrated embodiment, it comprises a latch member 250 mounted on pins 252 for pivotal movement on the holder 86'. Fig. 8A shows the latch member 250 in an upraised position, opening the mount 78' for receiving the upper umbilicus block 102. Fig. 8B shows the latch member 250 in a lowered position, covering the mount 78' and retaining the umbilicus block 102 therein. As Fig. 8B shows, the latch member 250 includes a relieved region that accommodates passage of the umbilicus 76 when the latch member 250 is lowered.

A pair of resilient tabs 256 on the latch member 250 mate within undercuts 258 on the holder 86' to releasably lock the latch member 250 in its lowered position. Manually squeezing in the area 260 above the resilient tabs 256 releases them from the undercuts 258.

The second and third umbilicus mounts 80 and 82 form a part of a one omega holder 104 carried on the yoke cross member 62. The mounts 80 and 82 take the form of spaced apart slotted apertures that secure the mid-portion of the umbilicus 76 to the yoke cross member 62. The mid-portion of the umbilicus 76 carries a pair of spaced apart resilient bushings 106 that snap-fit within the slotted second and third mounts 80 and 82 (see Figs. 4 and 7). The slotted mounts 80 and 82 allow the umbilicus bushings 106 to rotate within them, but otherwise secure the umbilicus 76 as the yoke assembly 50 rotates. The yoke cross member 62 carries a counterweight 103 opposite to the one omega

- 14 -

holder 104.

The fourth umbilicus mount 84 forms a part of a two omega holder 108 on the processing chamber assembly 52. As best shown in Figs. 15 and 19, the mount
5 84 comprises a clamp that captures a lower block 110 carried by the umbilicus 76. The clamp mount 84 grips the lower block 110 to rotate the lower portion of the umbilicus 76 as the chamber 22 itself rotates.

In the illustrated embodiment (see Fig. 19), the
10 lower umbilicus block 110 (like the upper umbilicus block 102) is generally hexagonally shaped. The clamp mount 84 is also configured to mate with the lower block 110 seated within it. As before pointed out, it should be appreciated that other mating shapes can be
15 used to seat the umbilicus block 110 within the clamp mount 84.

Further details of the fourth umbilicus mount 84 will be discussed later.

The zero omega holder 86 holds the upper portion
20 of the umbilicus in a non-rotating position above the rotating yoke and chamber assemblies 50 and 52. The holder 104 rotates the mid-portion of the umbilicus 76 at the one omega speed of the yoke assembly 50. The holder 108 rotates the lower end of the umbilicus 76
25 at the two omega speed of the chamber assembly 52. This relative rotation keeps the umbilicus 76 untwisted, in this way avoiding the need for rotating seals.

C. The One Omega/Two Omega Drive Control

30 The processing controller 32 includes an all-electrical synchronous drive controller 184 for maintaining the desired one omega/two omega relationship between the yoke assembly 50 and the chamber assembly 52. Fig. 10 shows the details of the drive controller
35 184.

- 15 -

As Fig. 10 shows, both motors 66 and 72 are three phase motors. Still, double or other multiple phase motors can be used, if desired. In the illustrated three phase arrangement, the drive controller 184 includes a three phase power driver 186. The drive controller 184 also includes a commutation controller 188 for three commutator sensors 190 associated with the first three phase electric motor 66.

The power driver 186 uses a single slip ring assembly 192 that serves the second electric motor 72. The slip ring assembly 192 includes three slip rings (designated RA, RB, and RC in Fig. 10), one associated with each pole of the second motor (designated PA, PB, and PC in Fig. 10). The slip rings RA/RB/RC serve as a conducting means for electricity. Alternative conducting means, such as a transformer coupling, could be used.

The power driver 186 includes three power feeds (designated FA, FB, and FC in Fig. 10) connected in parallel to the three poles PA/PB/PC of first electric motor 66. The power feeds FA/FB/FC operate the first motor 66 at the preselected constant one omega speed in a closed loop fashion.

The power feeds FA/FB/FC are, in turn, connected in parallel to the three poles PA/PB/PC of the second electric motor 72, each via one slip ring RA/RB/RC. The slip rings serve as a rotating electrical connector, transferring power between the first motor 66 (operating at constant speed and in a closed loop) and the second motor 72.

Since the poles PA/PB/PC of both motors 66 and 72 are connected directly together in parallel, a phase error will occur whenever the second motor 72 is not synchronous with the first motor 66. The phase error causes the two motors 66 and 72 to exchange power.

- 16 -

Depending upon the phase angle between the counter-electromotive force (emf) voltage vector generated by the rotor and the voltage vector of the feed line, the motors 66 and 72 will either transfer power from the feed lines FA/FB/FC to the rotors (through normal motor action) or deliver power from the rotors to a feed line FA/FB/FC (through generator action).

More particularly, if the rotor of the second motor 72 (spinning the chamber assembly 52) moves ahead of the rotor of the first motor 66 (spinning the yoke assembly 50), the second motor 72 becomes a generator, delivering power to the first motor 66. Because the first motor 66 operates in a closed loop at a constant speed, this power transfer retards the rotor of the second motor 72, causing the phase error to disappear.

Similarly, if the rotor of the second motor 72 lags behind the first motor 66, the first motor 66 becomes a generator, delivering power to the second motor 72. This power transfer advances the rotor of the second motor 72, again causing the phase error to disappear.

This continuous power exchange applies a corrective torque on the rotor of the second motor 72 that either advances or retards the rotor of the second motor 72. In either case, the corrective torque eliminates any phase error between the first and second motors 66 and 72. This keeps the second motor 72 continuously in synch with and operating at the same rotational speed as the closed loop, constant speed first motor 66.

This arrangement keeps the chamber assembly 52 spinning, relative to zero ω , at exactly two ω ; i.e., twice the one ω speed of the yoke assembly 50.

- 17 -

As the following Table illustrates, a drive controller 184 embodying the above features can be used to maintain virtual any speed ratio between two or more motors.

5

TABLE 1

<u>NUMBER OF POLES</u>		<u>SPEED RATIO MAINTAINED</u>
Motor 1	Motor 2	(Motor 2:Motor 1)
2	2	2:1
4	4	2:1
6	6	2:1
8	8	2:1
2	4	3:2
2	6	4:3
4	8	3:2
4	6	5:2
6	2	4:1
6	4	5:3

10

15

The drive controller 184 continuously maintains the desired speed ratio without noisy and heavy geared or belted mechanical mechanisms or without complicated, sensitive electronic feedback mechanisms. The drive controller 184 allows the centrifuge 16 to be small and lightweight, yet reliable and accurate.

20

25

D. The Centrifuge Drawer

The centrifuge drawer 36 moves the entire isolated mass of the centrifuge 16 (carried on the plate 45) across the axis of rotation. The drawer 36 moves the isolated mass between an operating enclosed position (shown in Figs. 2 and 6) and an opened position accessible to the user (shown in Figs. 1 and 12).

30

When in its enclosed position, the cabinet 18 shields all sides of the isolated mass of the centrifuge 16 during operation. When in its opened position, the isolated mass of the centrifuge 18 is with-

35

- 18 -

drawn from the cabinet 18. The user can access all sides of the centrifuge 16 either for maintenance or to conveniently and quickly load and unload the disposable processing assembly 14.

5 The centrifuge drawer 36 can be constructed in various ways. In the illustrated embodiment (as best shown in Fig. 3), the centrifuge base 42 (which supports the plate 45 upon the flexible isolation mounts 44) rides on tracks 38 within the cabinet 18. The
10 drawer 36 includes a housing 34 attached to the isolated base 42 for movement on the tracks 38. The housing 34 has a front handle 40 that the user can grasp to move the entire isolated mass of the centrifuge 16 along the tracks 38 between the enclosed and
15 opened positions.

 The controller 32 includes a user-accessible switch 114 (see Fig. 1) that operates a latch solenoid 116 for the drawer 36. The solenoid 116 normally locks the drawer 36 to keep the centrifuge 16 in its
20 enclosed operating position (as Fig. 6 shows). Preferable, the processing controller 32 includes an interlock 118 (see Fig. 14) that prevents operation of the solenoid 116 to unlock the drawer 36 whenever power is supplied to the centrifuge motors 66 and 72.

25 The interlock 118 also preferably retains the latch pin 94 in its engaged position with the zero omega holder 86 (as Fig. 6 also shows), keeping the holder 86 in its operating position during processing operations.

30 When power is not being supplied to the centrifuge motors 66 and 72, operation of the switch 114 moves the solenoid 116 to its unlocked position (as Fig. 11 shows). This frees the drawer 36, allowing the user to enter the centrifuge 16. Also, the latching pin 94 withdraws, freeing the zero omega holder 86
35

- 19 -

for pivotal movement on the support frame 88.

As Figs. 11 and 12 show, as the user opens the drawer 36, moving the isolated mass of the centrifuge 16 to its accessible position, the roller member 96 on the zero omega holder 86 travels along an interior ramp 112 within the cabinet 18. As the drawer 36 opens, the ramp 112 urges the zero omega holder 86 down against the biasing force of the spring 92, guiding the roller member 96 into and through the access opening 100.

Once the isolated mass of the centrifuge 16 is in its opened position (as Fig. 12 shows), the user can apply a downward force upon the spring biased zero omega holder 86 to free the upper umbilicus block 102 from the mount 78. Once freed from the block 102, the biasing spring 92 pivots the zero omega holder to a fully upraised and out-of-the-way position shown in phantom lines in Fig. 12 and in solid lines in Fig. 13.

As will be described in greater detail later, the ramp 112 also serves to guide the roller member 96 as the drawer 36 closes to return the zero omega holder 86 to its normal operating position.

E. The Two Omega Chamber Assembly

As Fig. 13 shows, once the centrifuge 16 occupies its accessible position outside the cabinet 18, the user can pivot the entire processing chamber assembly 52 about the yoke cross member 62 to an upright position convenient for loading and unloading the processing chamber 22 (Fig. 1 shows this, too). As Fig. 13 also shows, once in its upright position, the user can further open the entire processing chamber assembly 52 to further simplify loading and unloading operations.

- 20 -

1. Pivoting the Chamber Assembly for Loading

5 Figs. 15 to 18A/B/C show the details of the pivot assembly 194 for moving the processing chamber 52 into its upright position.

The pivot assembly 194 suspends the yoke cross member 62 between the yoke arms 60. The two omega chamber assembly 52 carried on the cross member 62 thereby rotates between a downward suspended position (shown in Fig. 4) and an upright position (shown in Fig. 15).

When operating, the chamber assembly 52 occupies the suspended position. The user places the chamber assembly 52 in the upright position for loading and unloading the processing chamber 22 after having placed the isolated mass of the centrifuge 16 in its accessible opened position outside the cabinet.

15 The pivot assembly 194 for the chamber assembly 52 may be constructed in various alternative ways. Figs. 15 to 18A/B/C to 18 show the details of one preferred embodiment. The Figures show only one side of the pivot assembly 194 in detail, because the other side is constructed in the same manner.

25 The pivot assembly 194 includes a pair of left and right pivot pins 196. Bearings 198 carry the pivot pins 196 on the yoke arms 60. A retainer bracket 200 secures each pivot pin 196 to the yoke cross member 62.

30 The pivot assembly 194 employs a swinging lock assembly 202 to control the extent and speed of rotation of the chamber assembly 52 on the pivot pins 96. The swinging lock assembly 202 includes a rotating cam 204 secured to the end of each pivot pin 196. Each cam 204 includes a cut out arcuate groove 206 (see Fig. 16) that ends at opposite first and second

35

detents, respectively 208 and 210. The groove 206 defines the range of rotation of the chamber assembly 52 on the pivot assembly 194.

5 The swinging lock assembly 202 also includes left and right locking pins 212 carried in the top of each yoke arm 60. Each locking pin 212 has an end key 214 that rides within the interior groove 206 of the associated cam 204. The opposite end of each locking pin 212 forms a control button for manipulation by the user at the top of the upright yoke arms 60.

10 The user can independently move each locking pin 212 between an upraised position (shown in Figs. 18A and 18C) and a depressed position (shown in Fig. 18B). The swinging lock assembly 202 uses a spring 218 to normally bias each locking pin 212 toward its upraised position.

15 When in its upraised position, the end key 214 of each locking pin 212 is captured within either the first detent 208 or the second detent 210 of the associated cam 204, depending upon the rotational position of the cam 204. When captured by either detent 208/210, the end key 214 prevents further rotation of the associated cam 204. When in its upraised position, the end key 214 locks the chamber assembly 52 into either its upright load position or its suspended operating position.

20 More particularly, when the first detent 208 captures the end key 214 of at least one locking pin 212 (as Fig. 18A shows), the locked cam 204 holds the chamber assembly 52 in its suspended operating position (shown in Fig. 4). When the second detent 210 captures the end key 214 of at least one locking pin 212 (as Fig. 18C shows), the locked cam 204 holds the chamber assembly 52 in its upraised load position (shown in Fig. 15).

- 22 -

When the user depresses the locking pin 212 (as Fig. 18B shows), the end key 214 moves out of the detent 208/210 and into the groove 206, freeing the associated cam 204 for rotation within the limits of groove 206. By freeing the end keys 214 of both locking pins 212 from their associated detents 208/210, the user pivots the chamber assembly 52 between its operating and load positions. Upon rotation from one detent position to the other, the biasing springs 218 automatically snap the end key 214 of each the locking pin 212 into the other detent as it reaches alignment with the end key 214, thereby automatically locking the chamber assembly 52 in the other detent position.

In the illustrated and preferred embodiment, the swinging lock assembly 202 also includes a biasing spring 220 associated with each cam 204. The springs 220 rotationally bias the cams 204 toward the position shown in Fig. 18C, where the second detent 210 captures the end keys 214 of the locking pins 212. Together, the springs 220 bias the chamber assembly 52 toward its upraised load position.

In this arrangement, by depressing both locking pins 212 with the chamber assembly 52 located in its downward operating position (Fig. 18A), the freed cams 204 automatically swing the chamber assembly 52 in response to the springs 220 into its upraised load position (Fig. 18C).

The swinging lock assembly 202 also preferably includes a damping cylinder 222 associated with each spring assisted cam 204. The damping cylinder 222 has a spring or pressure operated pin 224 that continuously presses against an outwardly radially tapered damping surface 226 on each cam 204. As it rides upon the tapered damping surface 226, the pin 224 progressively resists the spring-assisted rotation

- 23 -

of each cam 204, moving from the first detent 208 (the downward operating position) toward the second detent 210 (the upraised load position). The progressive resistance of the pin 224 slows the pivotal movement of the assembly 52, as the pin 224 comes to rest at the outermost radius of the ramp 226 (as Fig. 18B shows), which amounts to about 100 degrees of rotation from the suspended operating position. The user then pulls on the processing chamber 52 to rotate it about an additional 30 degrees to slip the pin 224 into a retaining notch 216 (as Fig. 18C shows). There, the biasing springs 218 of each locking pin 212 snap the end keys 214 into the second detents 210, locking the chamber assembly 52 in its upraised load position.

With the chamber assembly 52 located in its upraised position, the user can simultaneously depress both locking pins 212. The chamber assembly 52 will rotate about 30 degrees, until the pin 224 abuts against the ramped portion 217 of the notch 216. The user is then free to release the locking pins 212 without engaging the second detents 210 and manually pivot the chamber assembly 52 to free the pin 224 from the retaining notch 216. Further rotation against the action of the biasing springs 220 brings the chamber assembly 52 back to its operating position. There, the biasing springs 218 of each locking pin 212 snap the end keys 214 into the first detents 208 of the cams 204, preventing further rotation out of this position during processing.

As Fig. 15 shows, a protective cover 221 is preferably mounted on each side of the yoke arms 60 to enclose the pivot assembly 194 and associated components. This protective cover 221 has been removed or cut away in some of the drawings to simplify the discussion.

- 24 -

2. Opening the Chamber Assembly for Loading

As Figs. 13, 19 and 20 show, when locked in its upraised position, the user also can open the chamber assembly 52 for loading and unloading the replaceable processing chamber 22 in the manner shown in Fig. 1.

For this purpose, the chamber assembly 52 includes a rotating outer bowl 128 that carries within it an inner spool 130. In use, the inner spool 130 holds the processing chamber 22. The inner spool 130 telescopically moves into and out of the outer bowl 128 to allow the mounting and removal of the chamber 22 upon the spool 130.

The outer bowl 128 has a generally cylindrical interior surface 132. The inner spool 130 has an exterior peripheral surface 134 that fits telescopically within the outer bowl surface 132 (see Fig. 9). An arcuate channel 136 extends between the two surfaces 132 and 134. When mounted on the spool 130, the processing chamber 22 occupies this channel 136. The spool 130 preferably includes top and bottom flanges 138 to orient the processing chamber 22 within the channel 136.

The centrifuge assembly 12 includes a mechanism for moving the inner spool 130 into and out of the bowl 128. The mechanism can be variously constructed, and Figs. 19 to 24 show one preferred arrangement.

As Figs. 19 and 20 show, the outer bowl 128 is coupled to the second drive shaft 56. The inner spool 130 includes a center hub 140. A spool shaft 142 is secured to the hub 140 by a pin 144. The spool shaft 142 fits telescopically within the open bore of the second drive shaft 56.

The exterior surface of the spool shaft 142 has a hexagonal shape (as Fig. 21 best shows). The inte-

- 25 -

rior bore at the base 146 of the second drive shaft 56 has a mating hexagonal shape. The mating hexagonal surfaces couple the spool 130 to the bowl 128 for common rotation with the second drive shaft 56.

5 In the arrangement, the inner spool 130 is movable along the second drive shaft 56 between a lowered operating position within the outer bowl 128 (as Fig. 19 shows) and an unlifted loading position out of the outer bowl 128 (as Fig. 20 shows). As Fig. 21
10 best shows, the hub 140 preferably takes the shape of a handle that the user can easily grasp to raise and lower the spool 130.

As Figs. 19 and 20 show, the spool shaft 142 includes an axial keyway 148 having a lower detent 150
15 and an upper detent 152. The keyway 148 defines the range of up and down movement of the spool 130 within the bowl 128.

The bowl 128 includes a detent pin 154 that extends into the open bore of the second drive shaft 56.
20 A spring 156 biases the detent pin 154 into the keyway 148, where it rides into and out of releasable engagement with the lower and upper detents 150 and 152 as the user raises and lowers the spool 130.

In this arrangement, when the upper detent 152
25 engages the spring biased pin 154 (as Fig. 19 shows), the spool 130 is releasably retained in its lowered operating position. When the lower detent 150 engages the spring biased pin 154 (as Fig. 20 shows), the
30 spool 130 is releasably retained in its uplifted loading position. Normal external lifting and lowering force exerted by the user overcomes the biasing force of the spring 156 to easily move the spool 130 up and down between these two limit positions.

35 With the spool 130 locked in its uplifted position, the user can wrap the processing chamber 22 upon

- 26 -

the peripheral spool surface 134 (as Fig. 1 shows). With the spool 130 locked in its lowered position (see Fig. 19), the wrapped processing chamber 22 is sandwiched within the channel 136 between the spool 130 and the bowl 128. Rotation of the chamber assembly 52 subjects the processing chamber 22 to centrifugal forces within the channel 136.

A locking mechanism 158 prevents the spool 130 from dropping out of the bowl 128 while the chamber assembly 52 rotates in its downward suspended operating position.

The mechanism 158 includes locking pin 160 fastened to the bowl 128. The distal end of the locking pin 160 extends out through a passage 120 in the hub 140. The distal end includes a notch 122.

As Figs. 21 and 22 show, a latch member 124 slides on tracks 126 upon the handle end of the hub 140. The notched distal end of the locking pin 160 passes through an elongated slot 162 in the latch member 124. Springs 164 normally bias the latch member 124 toward a forward position on the handle end of the hub 140. In this position (shown in Fig. 24), the notch 122 engages the rear edge 163 of the slot 162. This engagement secures the spool 130 to the bowl 128. The latch member 124 is mass balanced so that centrifugal force will not open it during use.

As Fig. 23 shows, sliding the latch member 124 rearward frees the notch 122 from the rear slot edge 163. This releases the spool 130 from the bowl 128, allowing the user to lift the spool 130 from the bowl 120 in the manner previously described.

In the embodiment shown in Figs. 19 to 24, the sliding latch member 124 also forms a part of the two omega umbilicus clamp mount 84. As Figs. 21 and 23 show, sliding the latch member 124 rearward opens the

- 27 -

mount 84 to receive the lower umbilicus block 110. The spring assisted return of the latch member 124 to its forward position (shown in Fig. 24) captures the lower umbilicus block 110 within the mount 84. The
5 biasing springs 164 also hold the latch member 124 closed to clamp the block 110 within the mount during processing operations.

In this arrangement, the locking pin 160 is preferably flexible enough to be resiliently displaced
10 by the user (as the phantom lines in Fig. 24 show) to free the notch 122 from the rear slot edge 163 without operating the latch member 124. This allows the user to lift the spool 130 into its upraised position without freeing the lower umbilicus block (as Fig. 13
15 shows).

As Figs. 22 and 23 also show, the latch member 124 is preferably vertically moveable within the tracks to drop the rear slot edge 163 into engagement against the rear edge 166 of the hub handle. This
20 allows the user to temporarily secure the latch member 124 in its rearward position against the action of the biasing springs 164, freeing both of the user's hands to load the umbilicus 76. Lifting upward frees the rear slot edge 163, allowing the springs 164 to return
25 the latch member 164 to its forward clamping position.

Figs. 25 to 27 show an alternative locking mechanism 158 for the spool 130. In this arrangement, the second drive shaft 56 includes an undercut latchway 168. The hub 140 houses a latch pawl 170
30 carried by a pin 172 for pivotal movement between an engaged position with the latchway 168 (as Fig. 26 shows) and a disengaged position from the latchway 168 (as Figs. 25 and 27 show).

The hub 140 carries linkage 174 that operates
35 the latch pawl 170. The linkage 174 has a hooked end

- 28 -

176 coupled to the latch pawl 170 and a pin end 178 positioned in the path of a cam 180 carried by a latch lever 182. A pin 228 attaches the latch lever 182 to the hub 140 for pivotal movement between an unlatched position (shown in Figs. 25 and 27) and a latching position (shown in Fig. 26).

5
A spring 230 normally biases the linkage 190 to maintain the latch pawl 170 in its disengaged position when the latch lever 182 is in its unlatched position. In this orientation, the user is free to raise the spool 130 in the manner just described.

10
With the spool 130 in its lowered position, movement of the latch lever 182 to the latching position brings the cam 180 into contact with the pin end 178. Depressing the pin end 178 in turn moves the linkage 174 against the biasing force of the spring 230 to pivot the latch pawl 170 into its engaged position with the latchway 168. In this orientation, the interference between the latch pawl 170 and the latchway 168 prevents axial movement of the spool 130 along the second drive shaft.

15
20
When the latch lever 182 is in its latching position, spring biased pins 232 releasably engage detents 234 on the latch lever 182. The pins 232 releasably resist movement of the latch lever 182 out of its latching position. By applying deliberate lifting force to the latch lever 182, the user can overcome the spring biased pins 232 to move the latching lever 182 into its unlatched position.

25
30
35
In this arrangement, a holding bracket 236 associated with the latch lever 182 locks the lower umbilicus block 110 within the mount 84 while the spool 130 is locked into its lowered position. In this embodiment, the holding bracket 236 opens the mount 84 when the latch lever 182 is in its unlatched position

- 29 -

(shown in Fig. 25) and closes the mount 84 when the latch lever 182 is in its latching position (shown in Fig. 26).

5 F. Loading the Fluid Processing Assembly

 Figs. 28 to 31 show the details of loading a representative processing assembly 14 on the centrifuge 16, as is generally depicted in Fig. 1. The representative processing assembly 14 includes a processing chamber 22 formed as an elongated flexible tube or belt made of a flexible, biocompatible plastic material such as plasticized medical grade polyvinyl chloride. The umbilicus tubes 74 communicate with ports 248 to conduct fluids into and out of the processing chamber 22.

10

15

 The user begins the loading process by wrapping the flexible processing chamber 22 about the upraised and open spool 130.

 As Fig. 28 best shows, the spool 130 includes one or more alignment tabs 238 on the spool 130. The spool alignment tabs 238 register with alignment notches 240 on the processing chamber 22 to assure the desired orientation of the processing chamber 22 on the spool 130.

20

 Of course, the ways of aligning the chamber 22 on the spool 130 can vary. In the illustrated embodiment, the spool 130 has two alignment tabs 238A and 238B, and the processing chamber 22 has two mating alignment notches 240A and 240B. Alternatively, pins or other alignment mechanisms can be used.

25

30

 As Fig. 28 shows, one spool alignment tab 238A protrudes from the spool surface 134 and mates with the notch 240A on the processing chamber 22. The other spool alignment tab 238B protrudes from a flap 242 that extends from and overhangs a portion of the spool

35

surface 134.

5 In the illustrated embodiment, the flap 242 is hinged. It is movable between a raised position (shown in phantom lines in Fig. 28), away from the spool surface 134, and a lowered position (shown in solid lines in Fig. 28), facing toward the spool surface 134. By placing the flap 242 into its lowered position, the alignment tab 238B on the flap 242 fits within a retainer 244 in the spool surface 134.

10 In this arrangement, with the flap 242 upraised, the user aligns the notch 240A with the tab 238A and aligns the notch 240B over the retainer 244. Lowering the flap 242 places the tab 238B into the retainer 244, capturing the notch 240B between the flap 242 and the spool surface 134 (as Fig. 28 shows) to hold the processing chamber 22 in place.

15 Instead of a hinged flap 242, a flap fixed in the lowered position can be used. In this arrangement, the user tucks the processing chamber 22 beneath the flap.

20 As Fig. 29 shows, the user completes the loading process by overlapping the free ends of the processing chamber 22 on the opposite side of the spool 130. A clip 246 captures the overlapping ends, holding them close against the spool surface 134. Alternatively, an adhesive tab (not shown) can be used to hold the overlapping ends of the processing chamber 22 together, as could pins mating with associated holes in the processing chamber 22.

25 30 The user then lowers and locks the spool 130 within the bowl 128 in the manner previously described to complete the loading process (as Fig. 30 shows). The user clamps the lower umbilicus block 110 into the mount 84 in the manner previously described and pivots the chamber assembly 52 into its downward suspended

35

- 31 -

position shown in Fig. 4.

5 The user then snaps the umbilicus bushings 106 into position in the slotted second and third mounts 80 and 82 on the one omega holder 104, as Fig. 4 shows. The user lowers the zero omega holder 86 toward the rotating components 50 and 52 of the centrifuge 16 to seat the upper block 102 into the mount 78.

10 The user closes the drawer 36 and completes the loading process by placing the tubes 74 into operative alignment with the pumps 28 and clamps 30 on the front panel of the cabinet 18.

15 The user generally follows a reverse sequence of steps to unload the fluid processing assembly 14.

G. Shaping the Processing Chamber

20 The interior bowl surface 132 and the exterior spool surface 134 are preformed to create within the high-G and low-G regions of the processing chamber 22 the specific contours required either to get the desired separation effects or to achieve optimal priming and air purging, or both.

25 In the embodiment shown in Fig. 32, the interior bowl surface 132 is preformed with a constant outer radius (as measured from the rotational axis). In this arrangement, the exterior spool surface 134 is preformed with contours of varying radii (also as measured from the rotational axis) to present the desired geometry for the low-G region.

30 For areas where a non-iso-radial geometry on the high-G wall is desired, the chamber assembly 52 includes an overhanging attachment on the spool 130 extending between the low-G spool surface 134 and the high-G bowl surface 132. In the illustrated embodiment
35 the attachment comprises the hinged flap 242

- 32 -

previously described. As Fig. 31 shows, the flap 242 is clipped, fastened by screws, or otherwise conveniently attached to the spool 130.

5 In this arrangement, all structures that create the desired contours in both the high-G and low-G regions of the chamber 22 are associated with the inner spool 130. In this way, changes in the contours to do different procedures or air purging methods can be made simply by changing the spool 130.

10 As Fig. 32 shows, the user can completely separate the spool 130 from the bowl 128 by pulling up on the spool 130 to fully release the spool 130 from the locking pin 160. Since the spool 130 contains the desired contour forming surfaces for the processing
15 chamber 22, the user can easily and quickly remove and exchange a spool having one configuration with a spool having another configuration.

Various features of the invention are set forth in the following claims.

I claim:

1. A centrifugation system comprising
a frame enclosing an interior area,
a centrifuge assembly including a chamber
and means for rotating the chamber about an axis, and
5 a base for supporting the centrifuge assembly on the frame including track means for moving the base and, with it, the centrifuge assembly between a first position within the interior area of the frame blocking access to the centrifuge assembly and a second
10 position outside the interior area of the frame permitting access to the centrifuge assembly.

2. A centrifugation system comprising
a frame enclosing an interior area,
a centrifuge assembly including a chamber,
means for rotating the chamber about an axis, and a
5 processing element removably insertable into the chamber for receiving fluids to undergo centrifugal separation during rotation of the chamber,
a base for supporting the centrifuge assembly on the frame including track means for moving the
10 base and, with it, the centrifuge assembly between a first position within the interior area of the frame blocking access to the centrifuge assembly and a second position outside the interior area of the frame permitting access to the centrifuge assembly for insertion and removal of the processing element.

3. A system according to claim 1 or 2 and further including force dampening means between the centrifuge assembly and the base for isolating the base from vibration and oscillation caused by the rotating chamber.
5

4. A system according to claim 1 or 2 wherein the track means moves the base in a direction generally perpendicular to the rotation axis

- 34 -

of the chamber.

5. A system according to claim 1 or 2 wherein the frame includes a drawer moveable in the track means between a closed position and an opened position, and

5 wherein the centrifuge assembly base is mounted within the drawer to locate the centrifuge assembly in its first position when the drawer is closed and to locate the centrifuge assembly in its second position when the drawer is opened.

6. A system according to claim 5 and further including means for locking the drawer in its closed position.

7. A system according to claim 5 and further including interlock means for preventing opening of drawer when the chamber is rotated.

8. A centrifugation system comprising a frame enclosing an interior area, a centrifuge assembly including a chamber, means for rotating the chamber about an axis, 5 a processing element removably insertable into the chamber,

an umbilicus for conveying fluid into the processing element to undergo centrifugal separation during rotation of the chamber,

10 a base for supporting the centrifuge assembly on the frame and including

holder means including mounting means for releasably receiving the umbilicus, the holder means being moveable between an operating position for orienting the umbilicus within the mounting means in 15 a prescribed relationship with the centrifuge assembly and a nonoperating position spaced away from centrifuge assembly and allowing user access to the chamber,

- 35 -

20 track means for moving the base and,
with it, the centrifuge assembly and holder means be-
tween an enclosed position within the interior area of
the frame blocking access to the centrifuge assembly
and holder means and an exposed position outside the
25 interior area of the frame permitting access to the
centrifuge assembly and holder means for insertion and
removal of the processing element in the chamber and
mounting and removing the umbilicus on the holder
means, and

30 means for moving the holder means to-
ward its operating position during movement of the
base toward the enclosed position and for moving the
holder means toward its nonoperating position during
movement of the base toward the exposed position.

9. A system according to claim 8

and further including locking means for re-
taining the holder means in its operating position
when the base is in its enclosed position.

10. A system according to claim 9

wherein the locking means is freed in re-
sponse to movement of the base from its enclosed posi-
tion toward its exposed position.

11. A system according to claim 8

5 and further including force dampening means
between the base and the centrifuge assembly and the
holder means for isolating the base from vibration and
oscillation of the centrifuge assembly and holder
means caused by the rotating chamber.

12. A system according to claim 8

wherein the track means moves the base in a
direction generally perpendicular to the rotation axis
of the chamber, and

5 wherein the means for moving the holder
means pivots the holder means generally axially of the

- 36 -

rotational axis.

13. A system according to claim 8

wherein the frame includes a drawer moveable in the track means between an closed position and an opened position, and

5 wherein the centrifuge assembly base is mounted within the drawer to locate the centrifuge assembly and the holder means in the enclosed position when the drawer is closed and to locate the centrifuge assembly in its exposed position when the drawer is
10 opened.

14. A system according to claim 13

wherein the drawer has an open top to allow user access to the centrifuge assembly when the drawer is opened.

15. A system according to claim 14

5 wherein the holder means orients the umbilicus in a prescribed relationship above the centrifuge assembly when in its operating position and is spaced away from centrifuge assembly when in its nonoperating position to allow user access to the chamber through the open top of the drawer when the drawer is opened.

16. A system according to claim 13

wherein the drawer means moves the base in a direction generally perpendicular to the rotation axis of the chamber, and

5 wherein the means for moving the holder means pivots the holder means generally axially of the rotational axis during movement of the drawer means.

17. A system according to claim 8

5 wherein the means for moving the holder means includes first means for biasing the holder means toward its nonoperating position and second means for retaining the holder means in its operating position against the force of the first means when the

- 37 -

base is in its enclosed position.

18. A system according to claim 17

wherein the second means includes locking means for retaining the holder means in its operating position when the base is in its enclosed position and means for releasing the locking means in response to movement of the base from its enclosed position toward its exposed position to allow the first means to urge the holder means towards its nonoperating position.

5

1/24

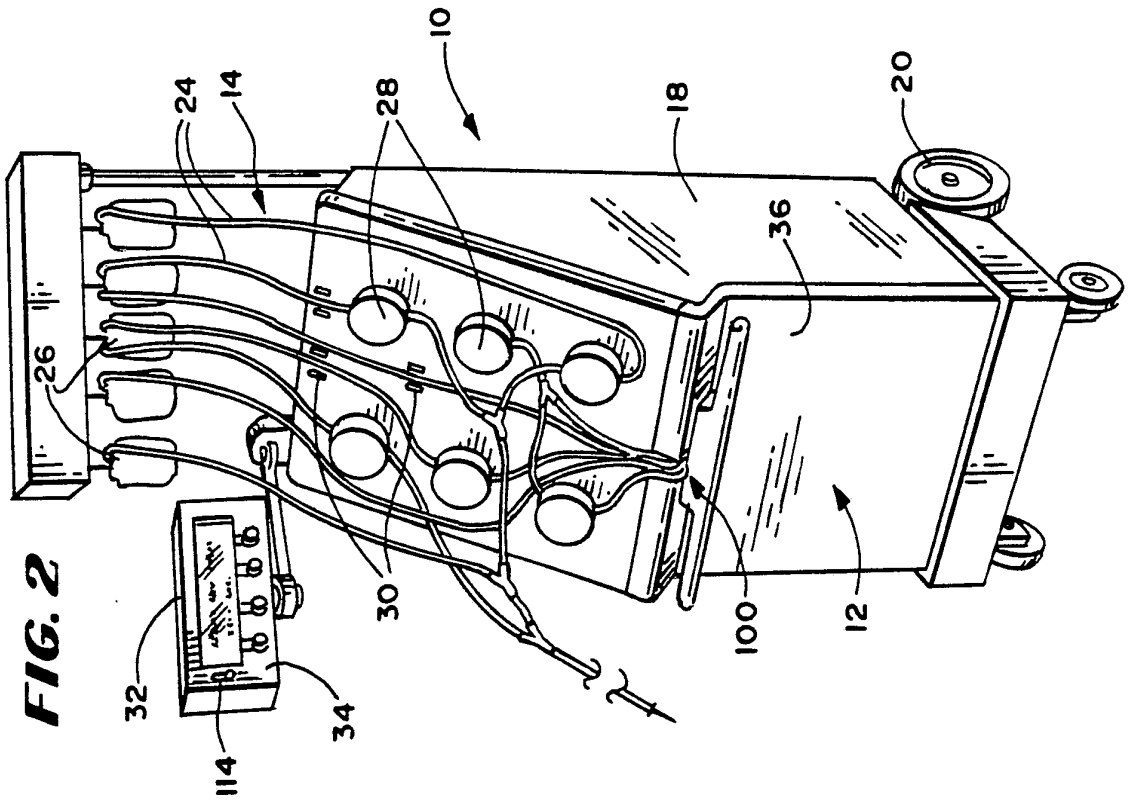

FIG. 2

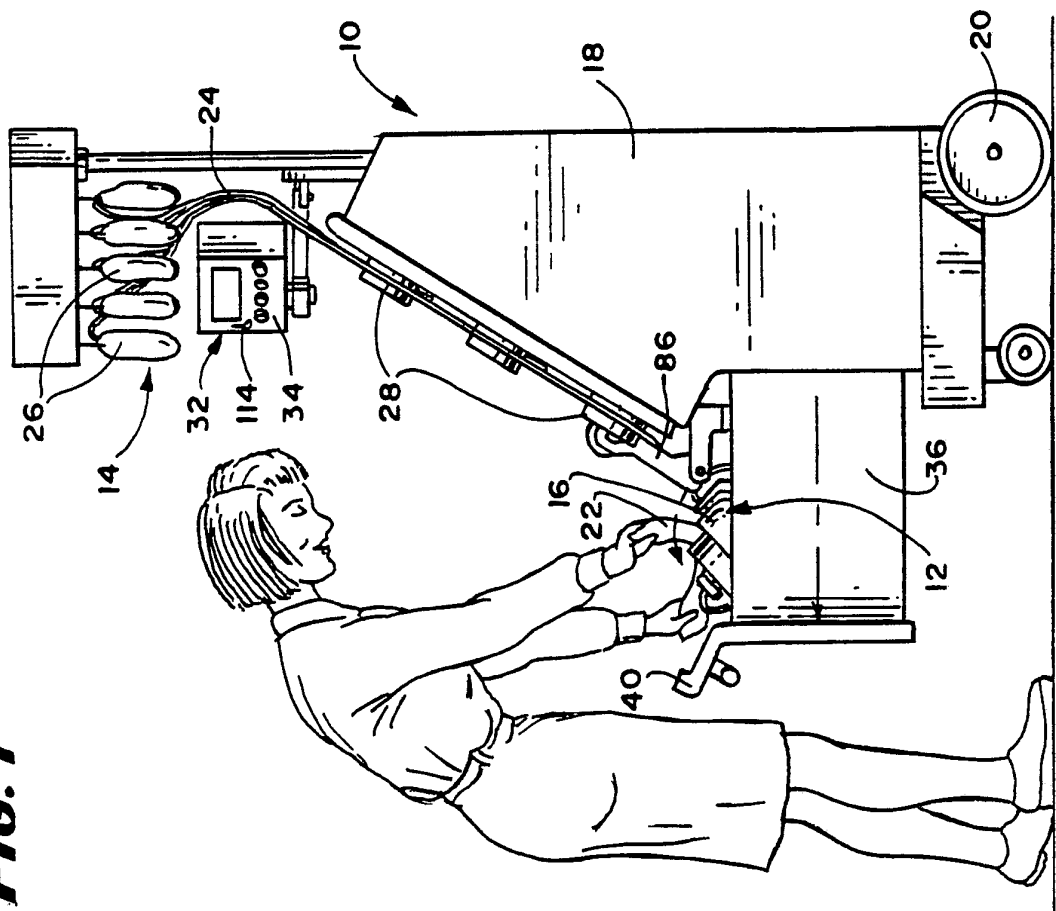

FIG. 1

FIG. 3

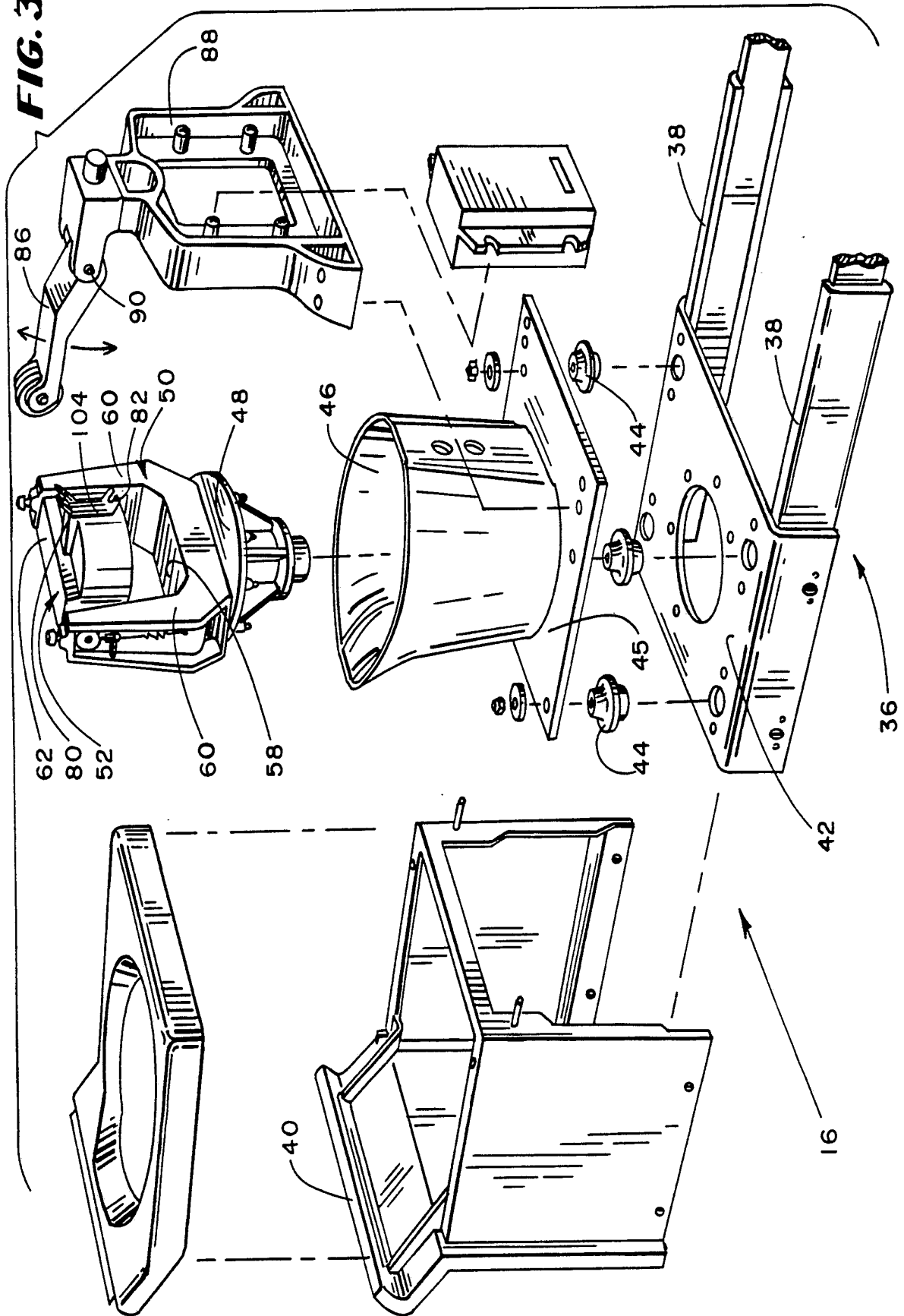
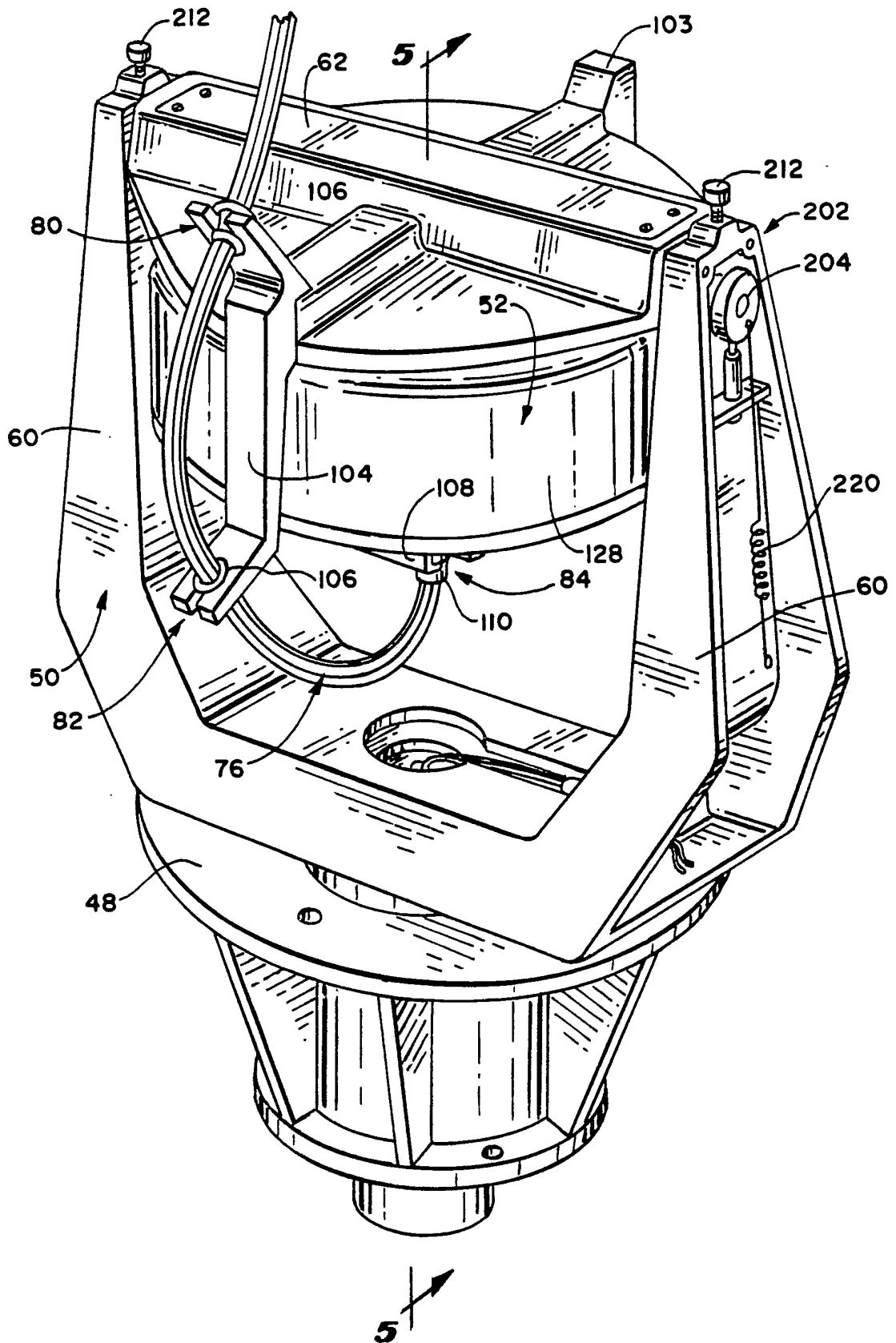
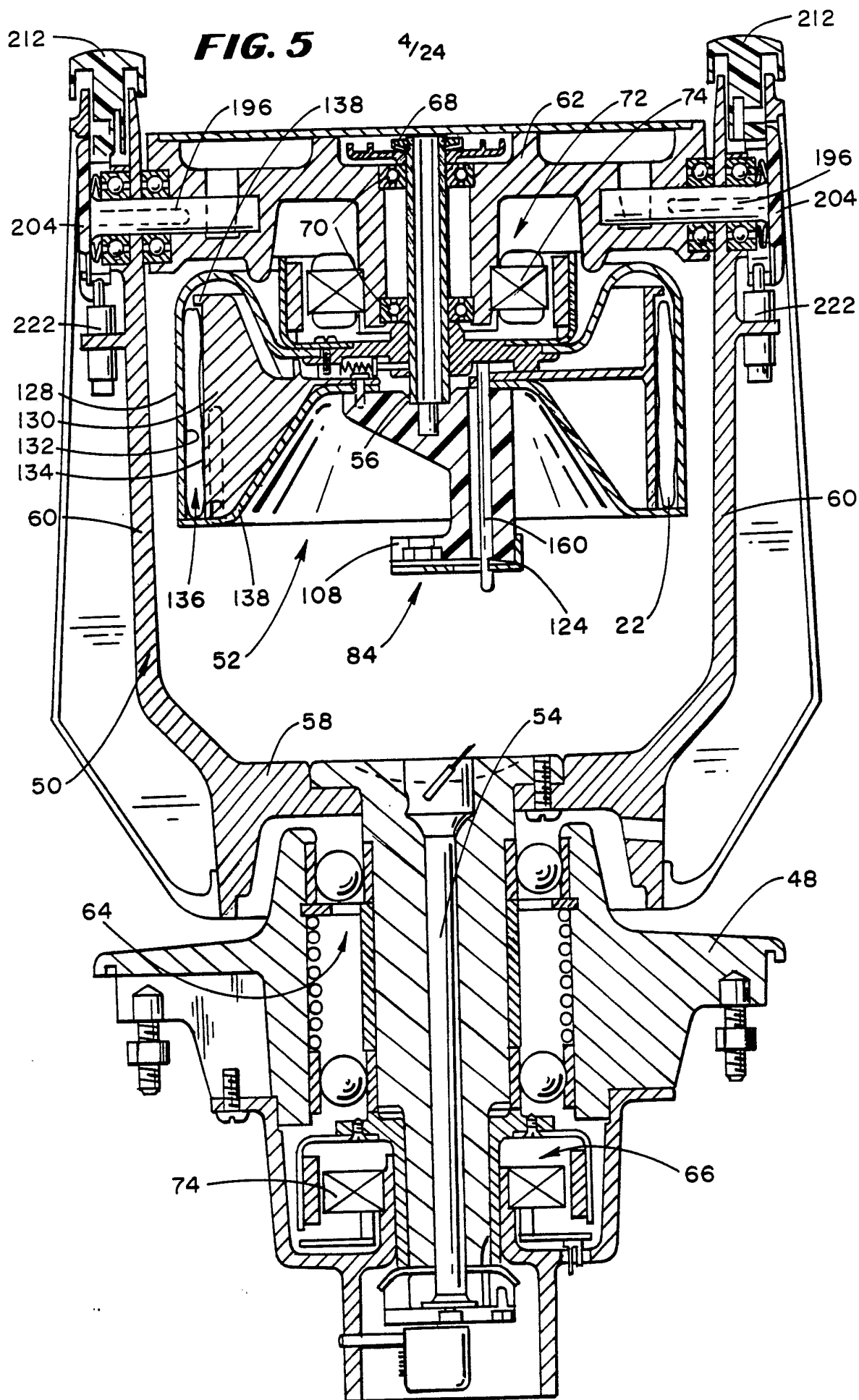

FIG. 4

3/24





5/24

FIG. 6

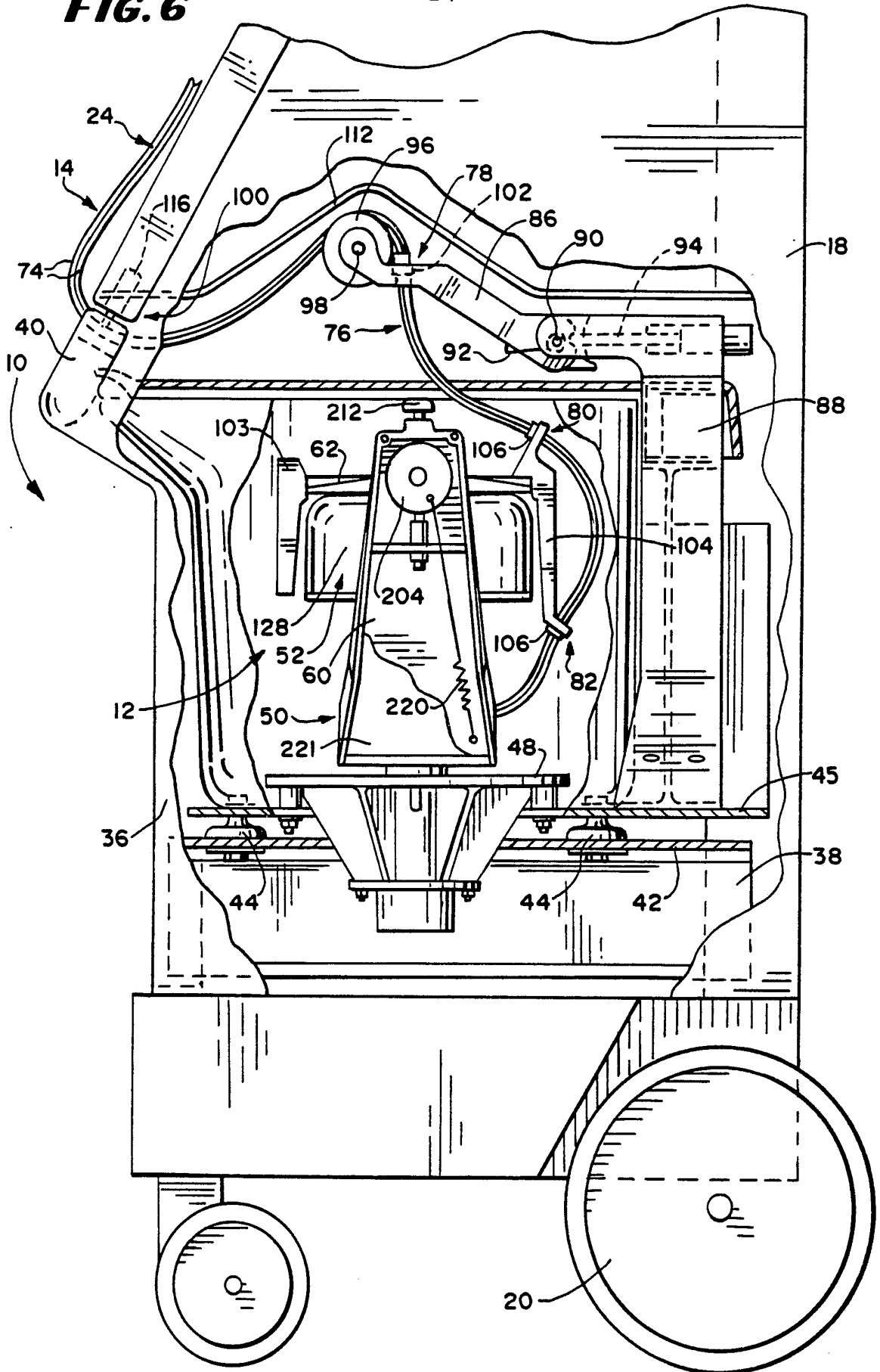

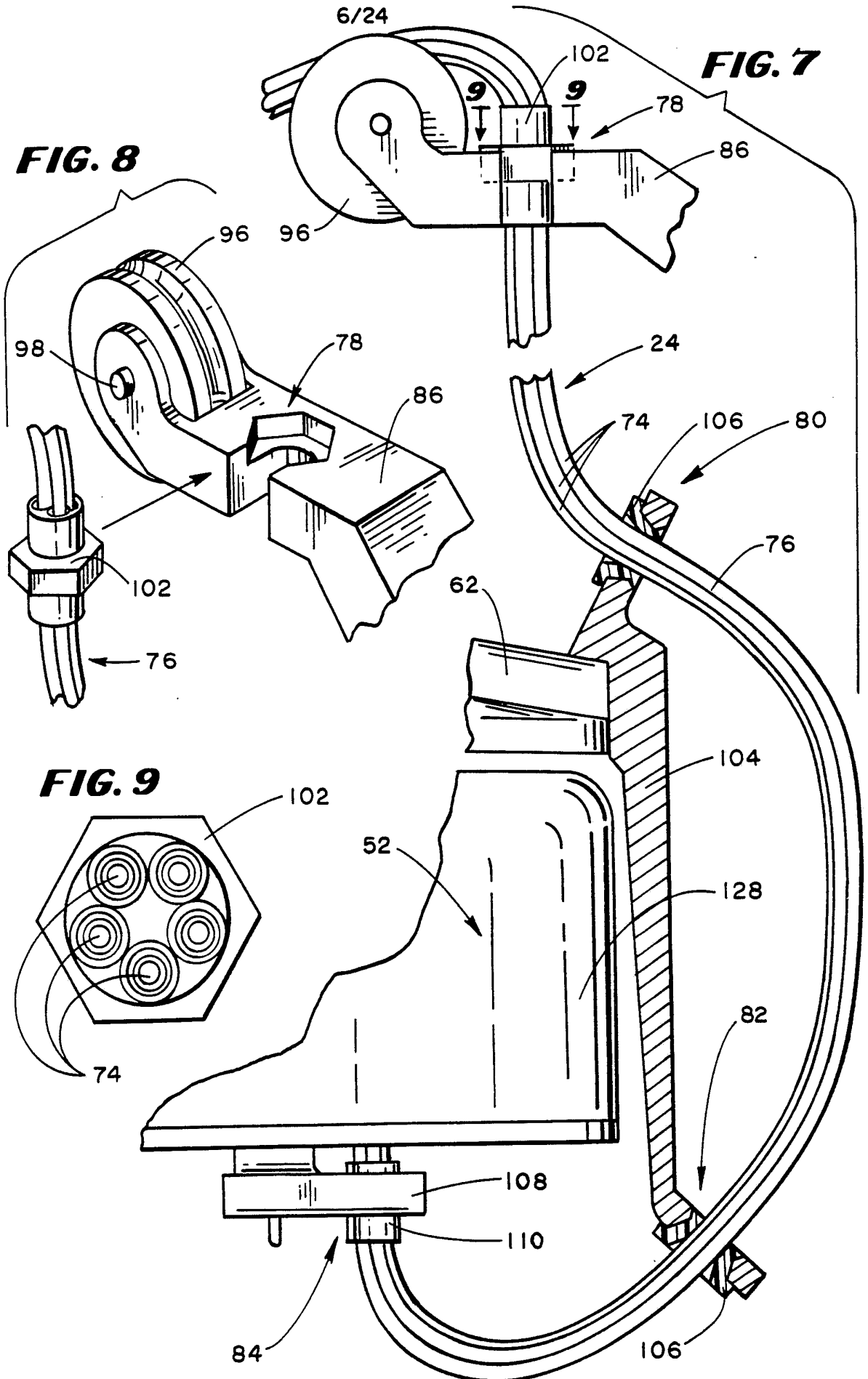

FIG. 8A

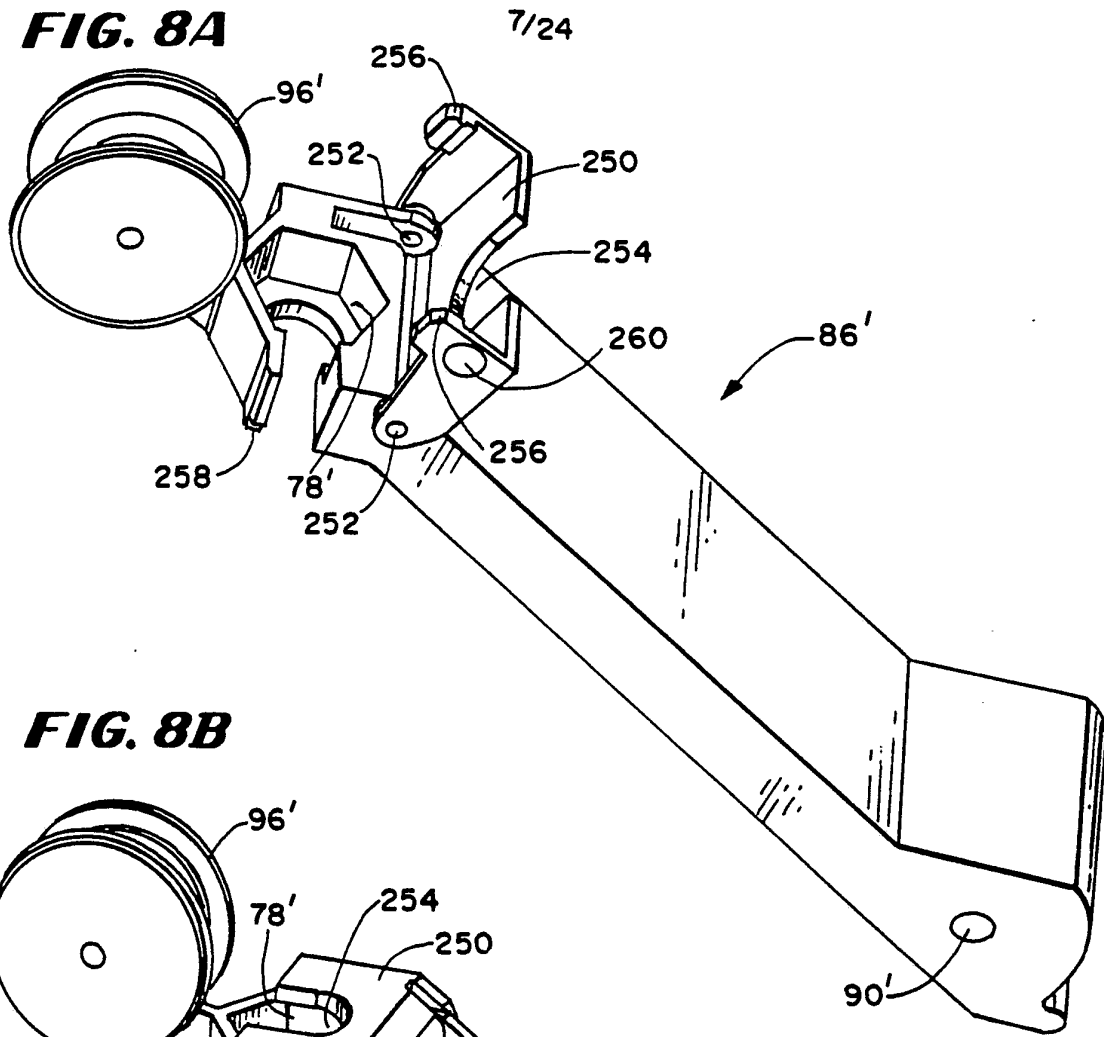
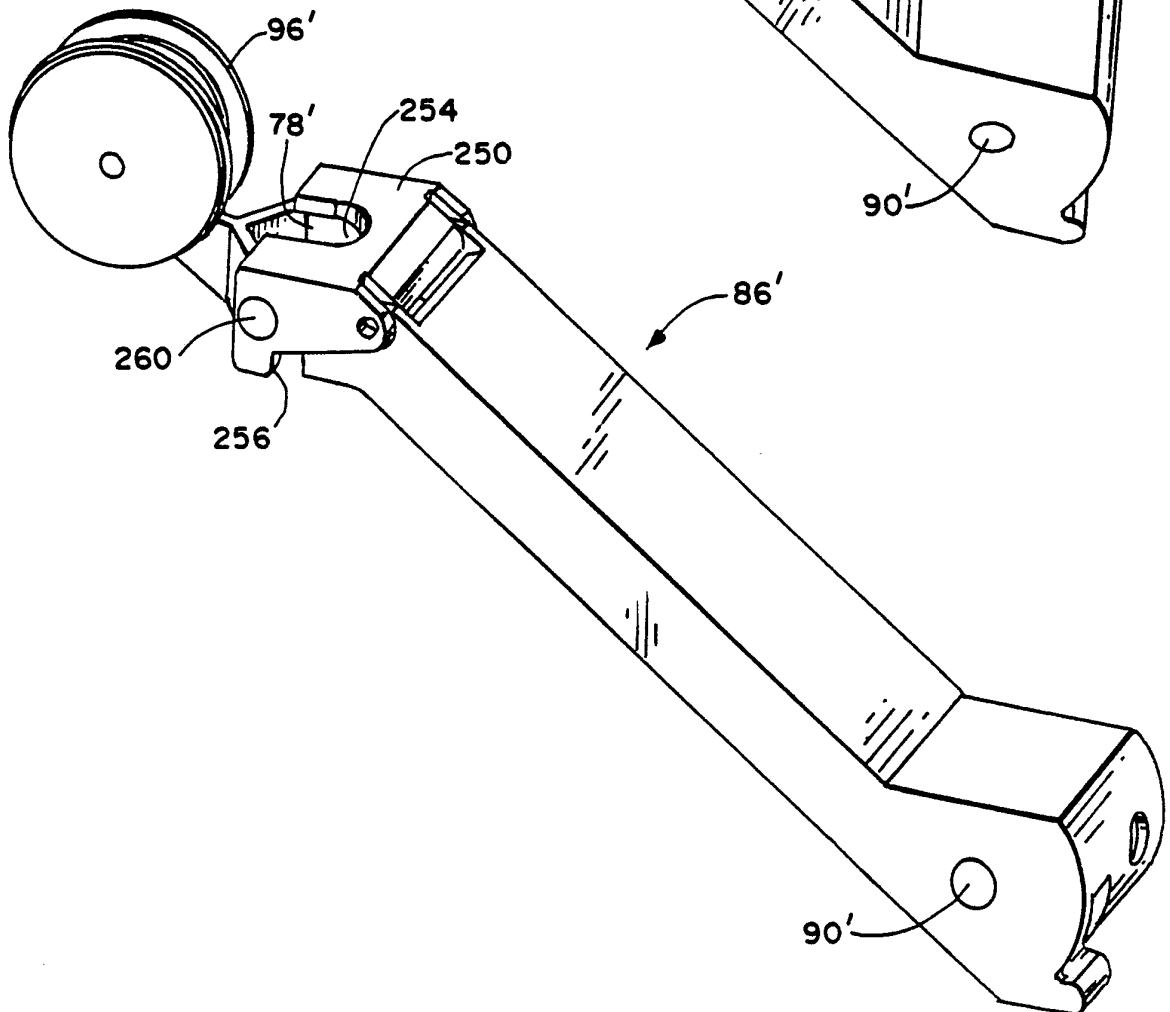
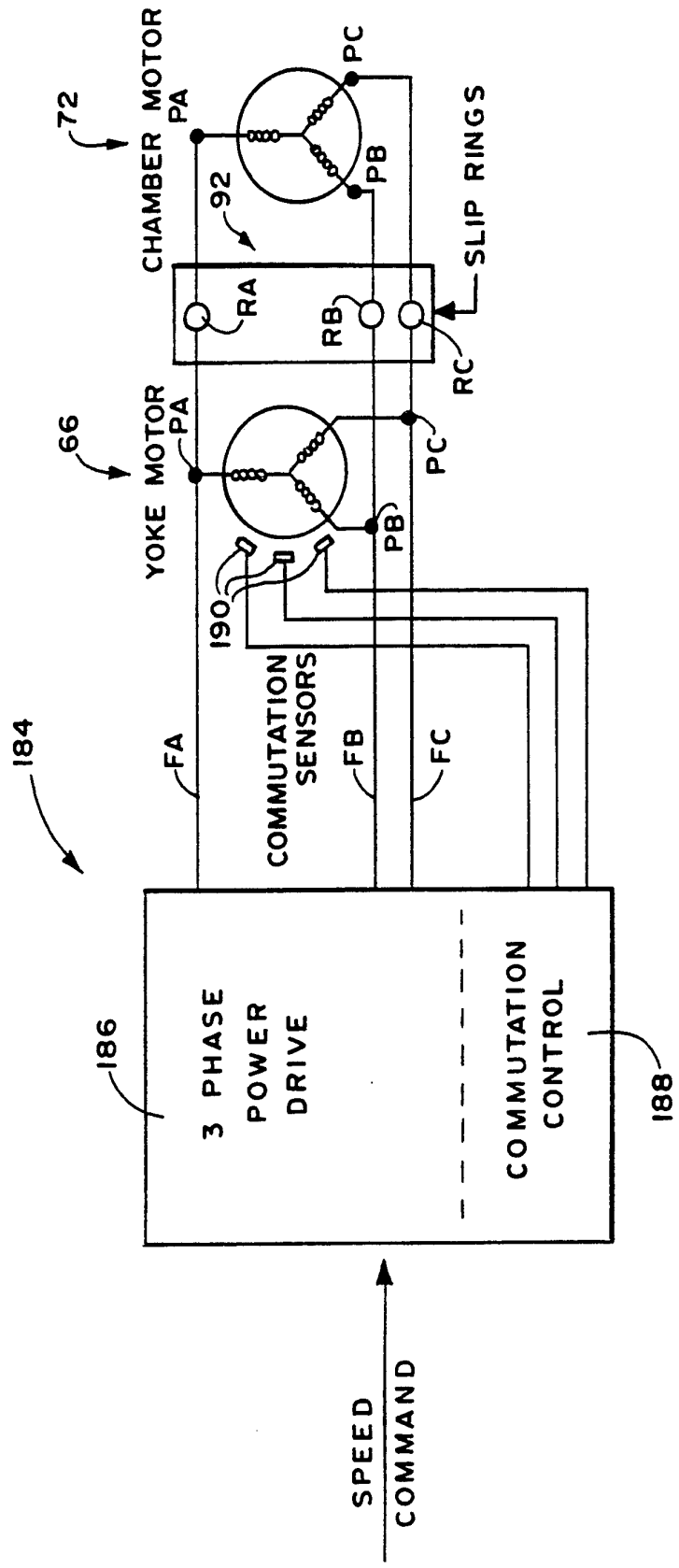

FIG. 8B



8/24

FIG. 10



9/24

FIG. 11

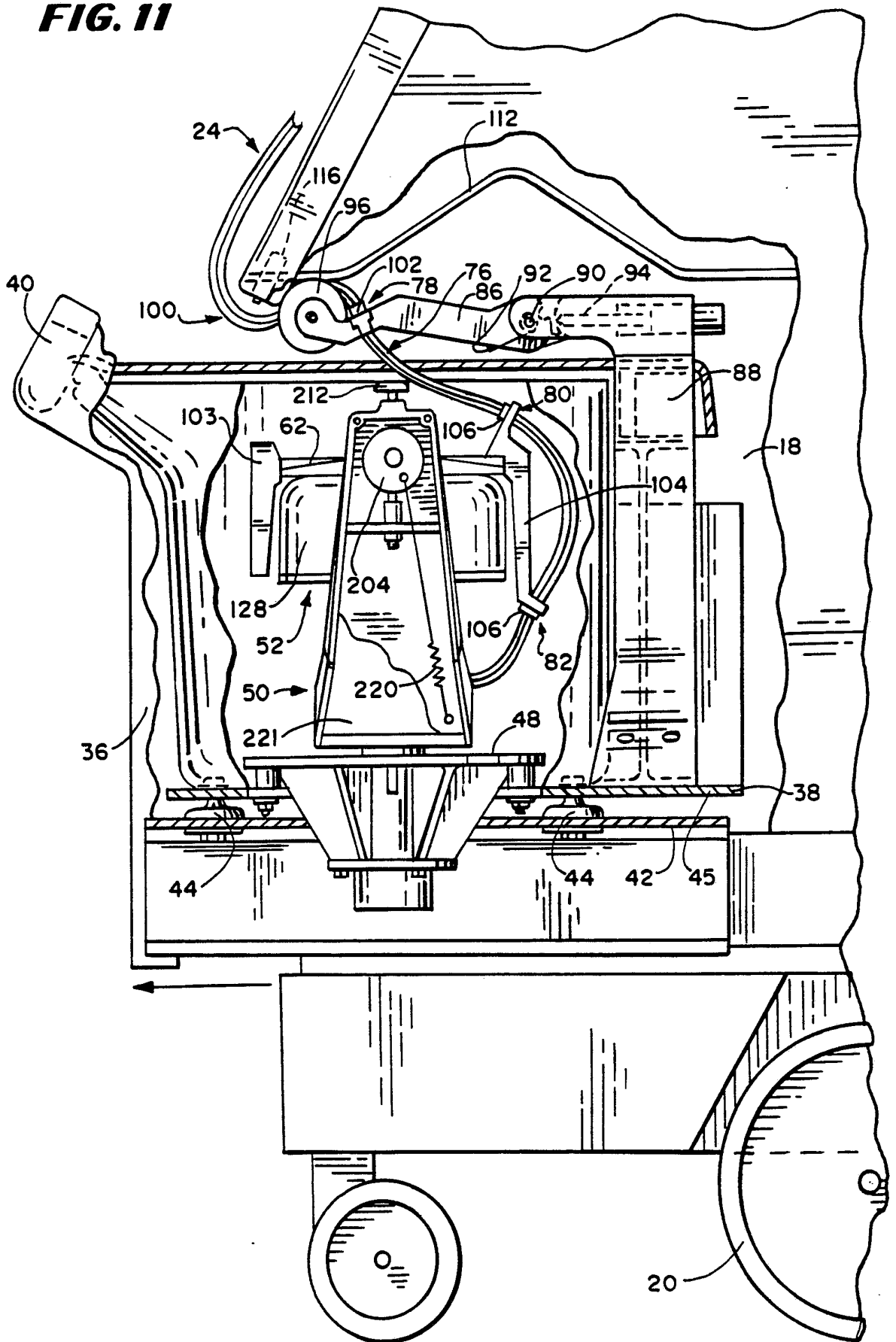

10/24

FIG. 12

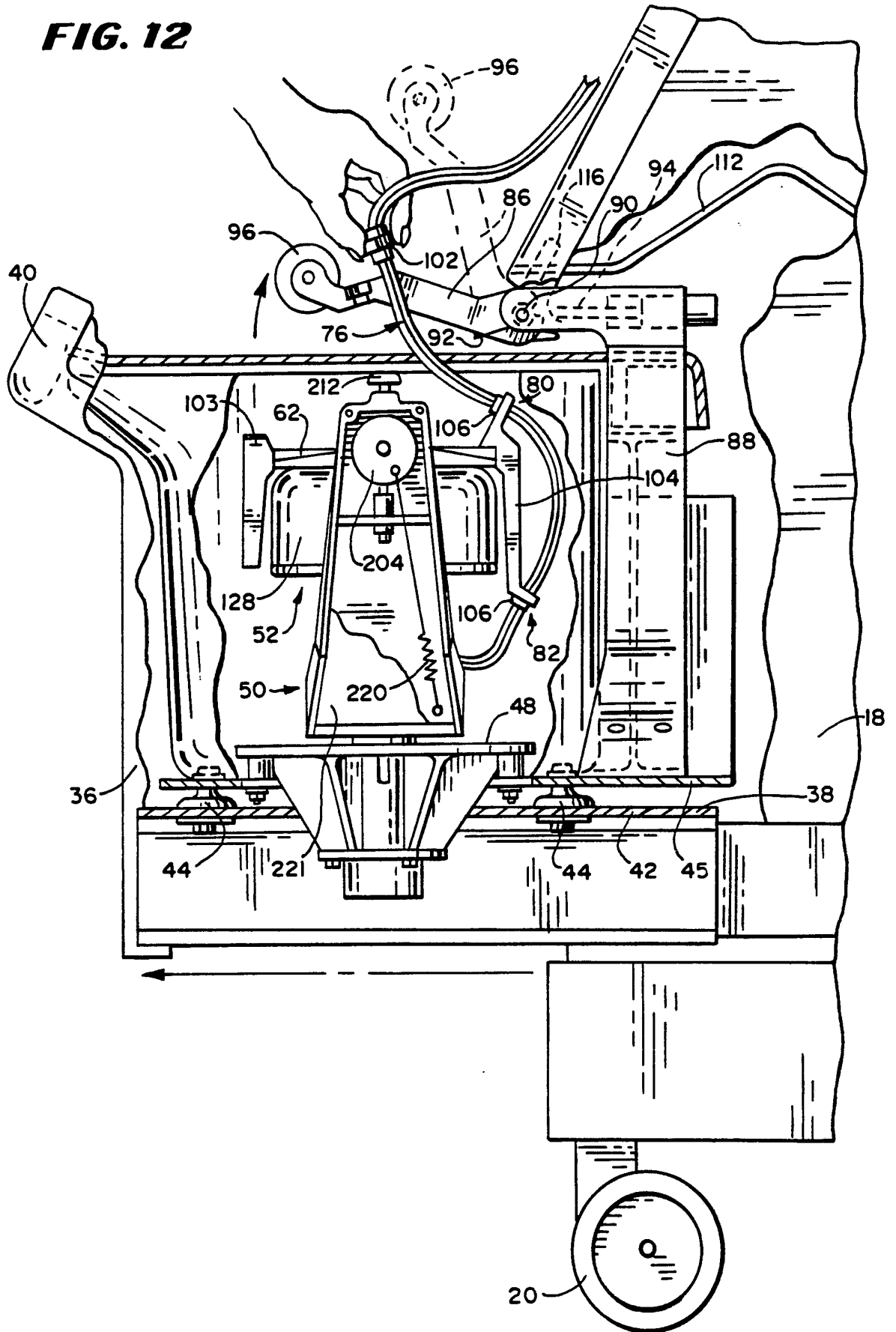

11/24

FIG. 13

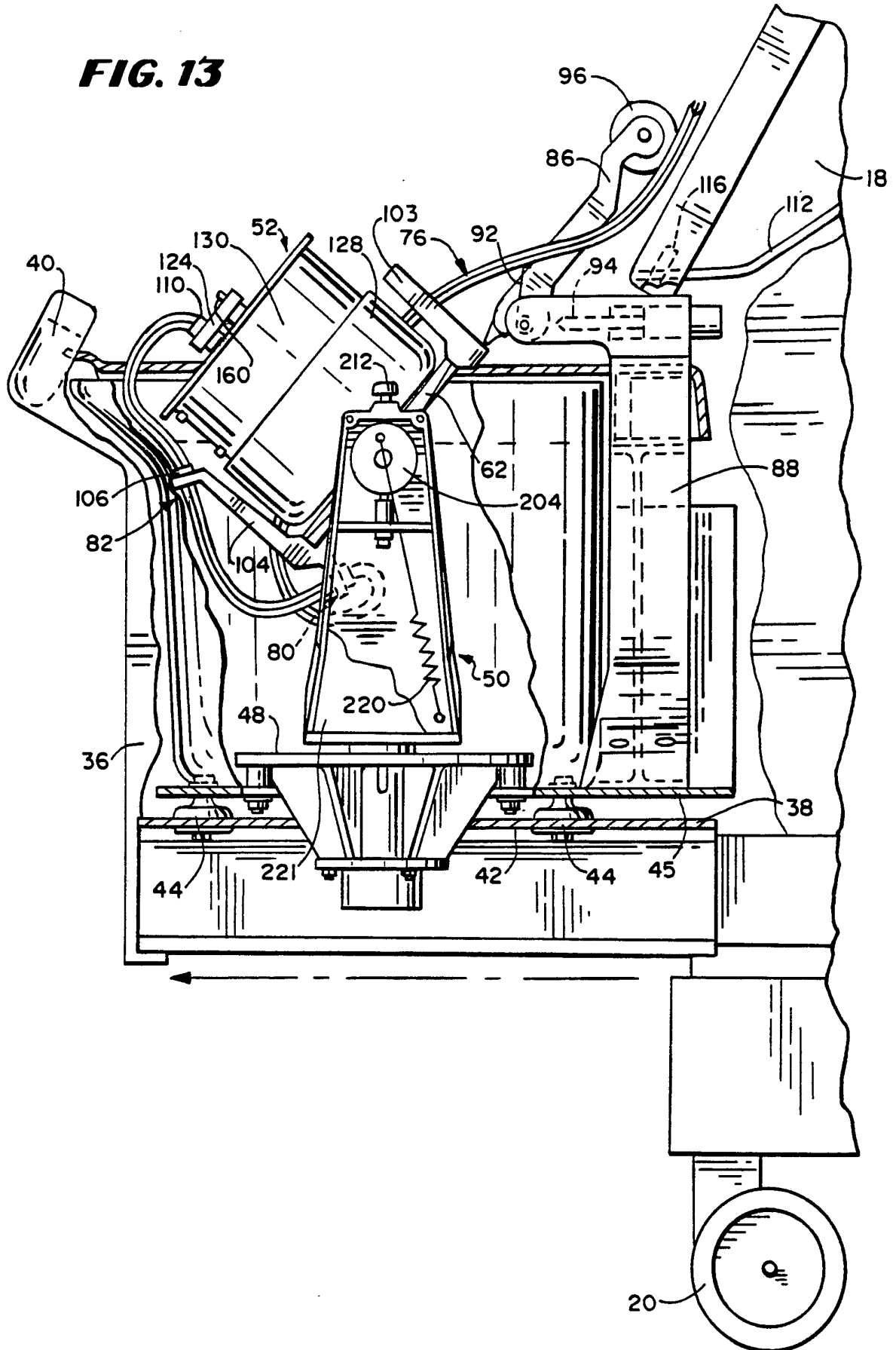

12/24

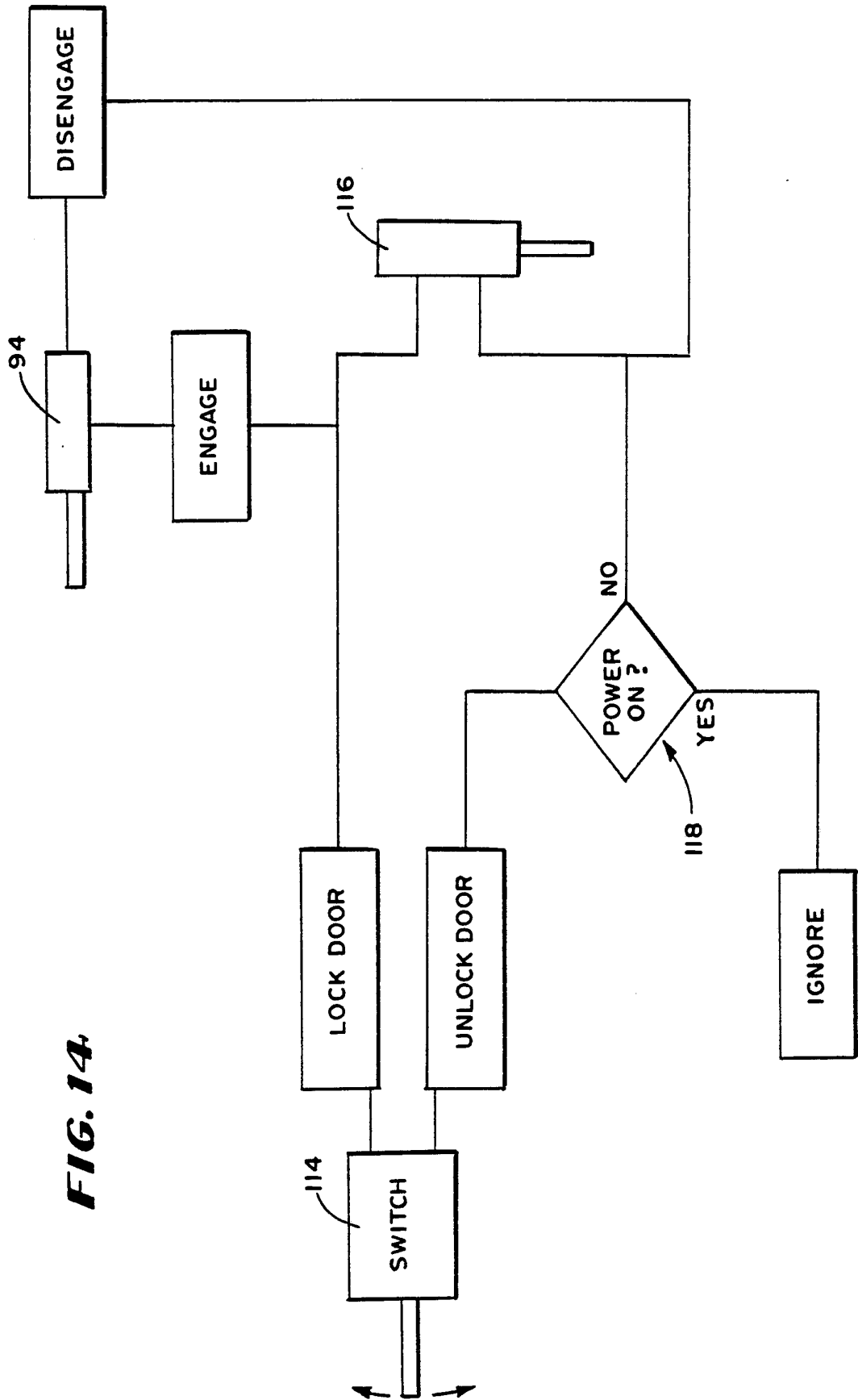
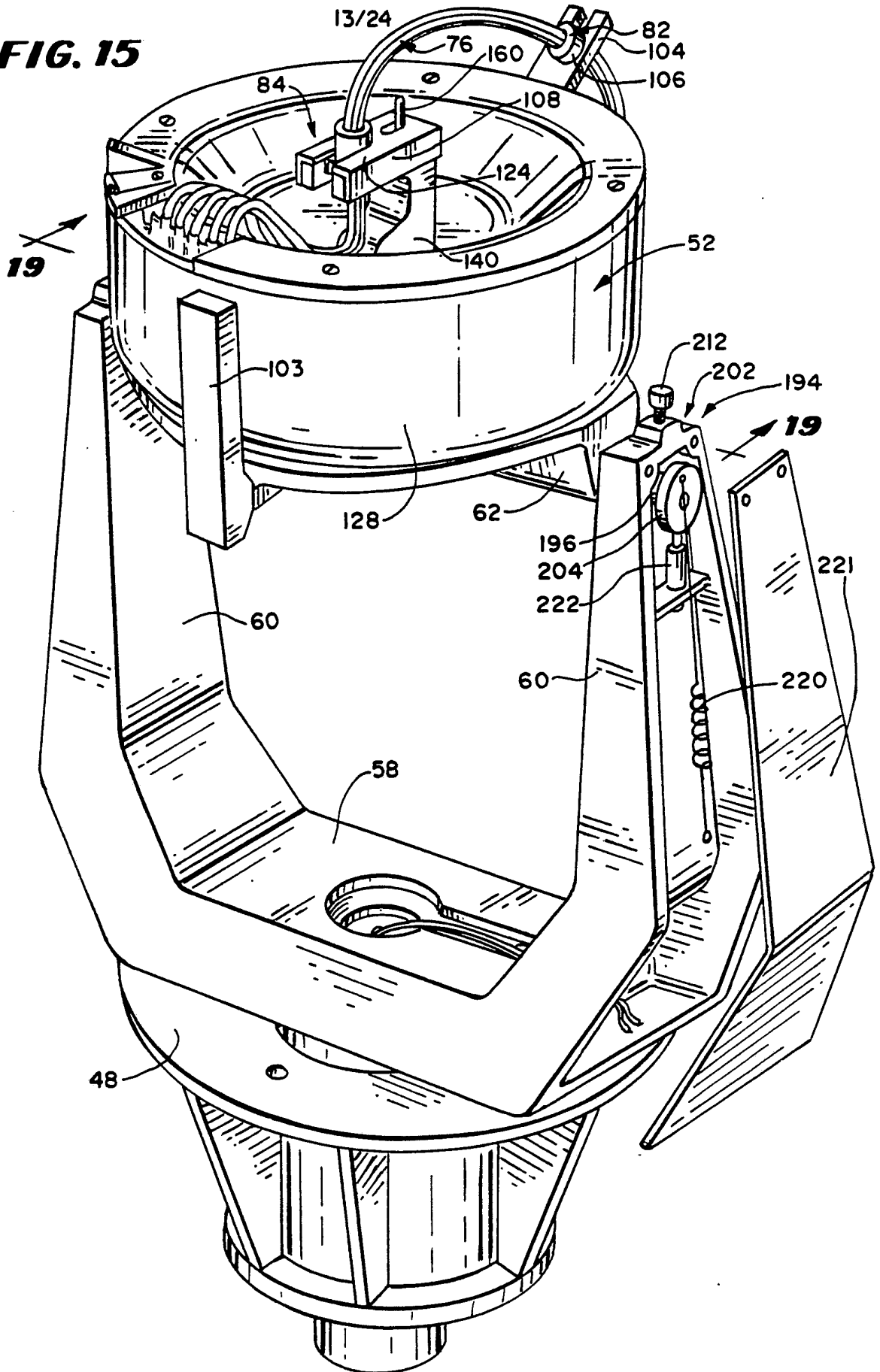

FIG. 14

FIG. 15



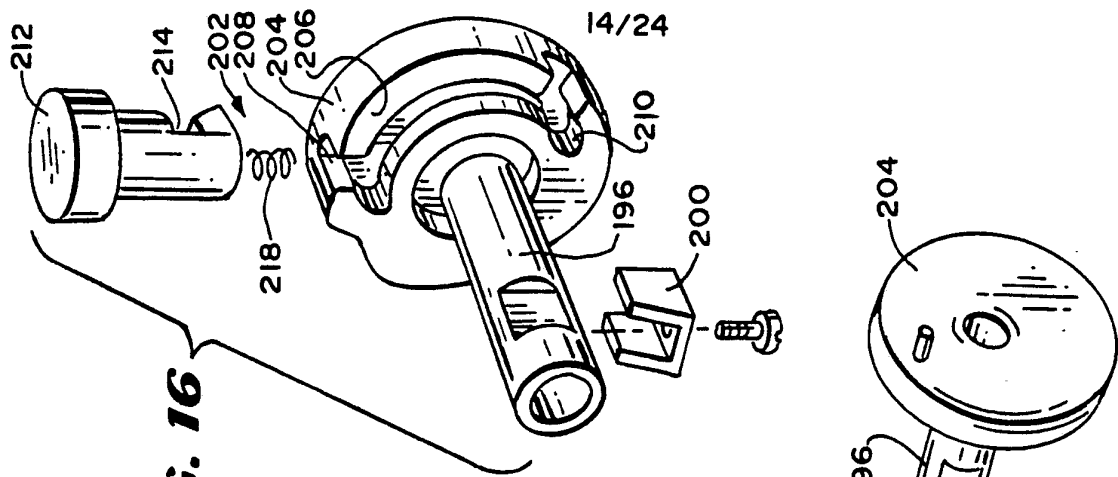

FIG. 16

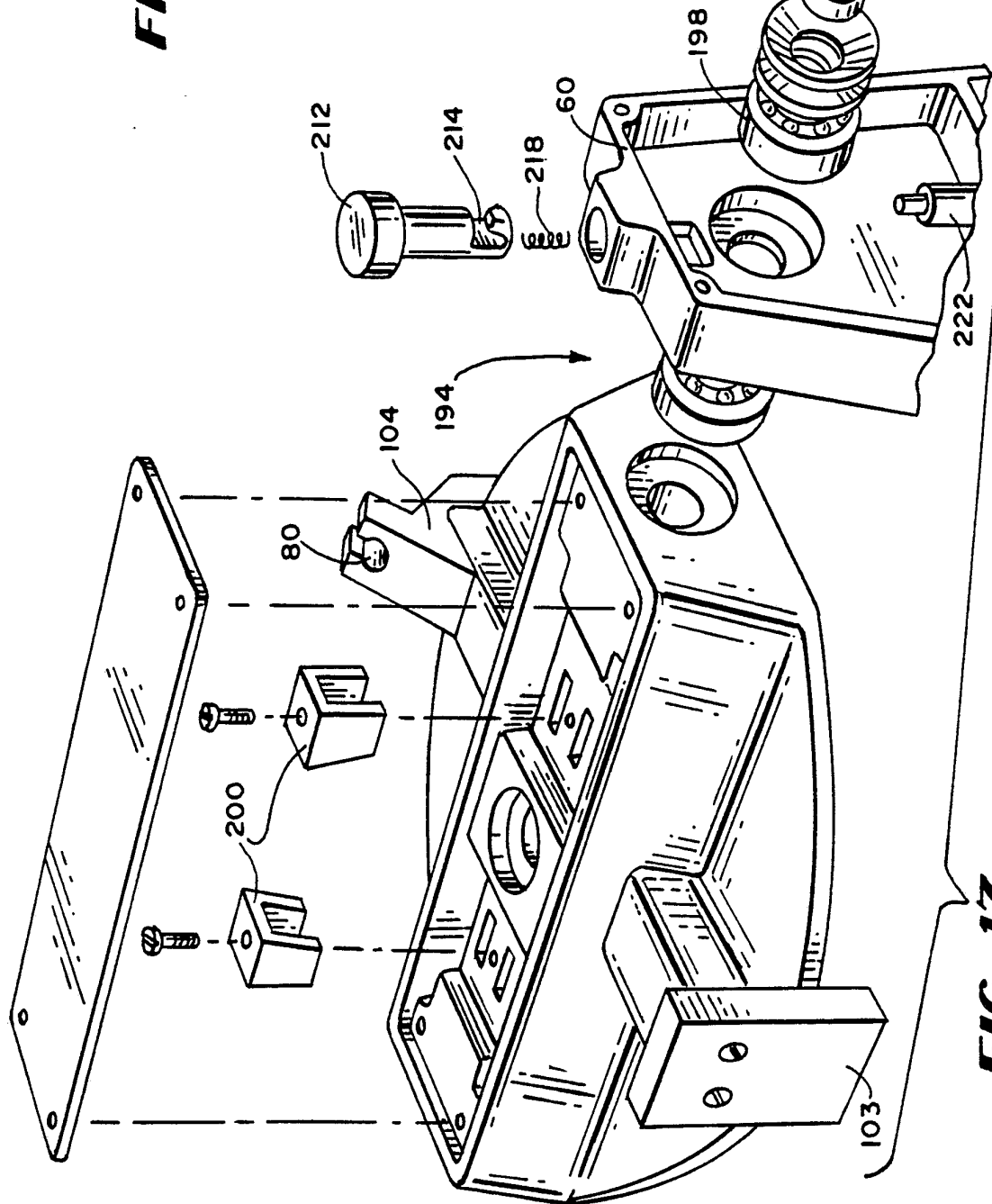

FIG. 17

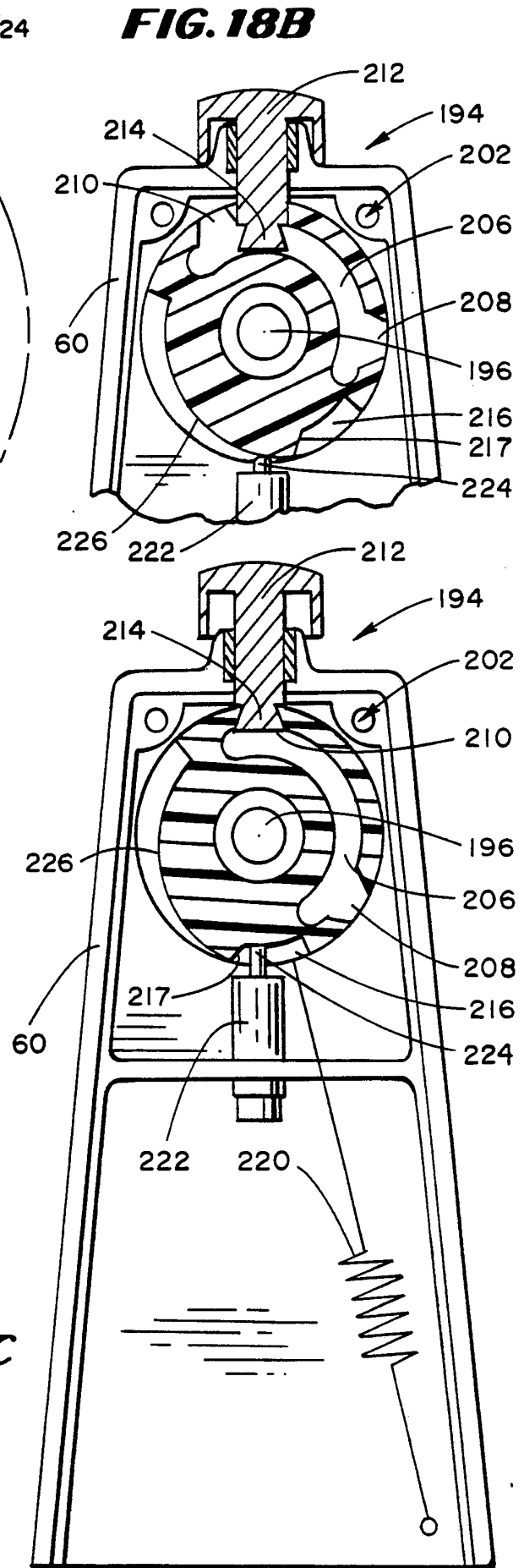
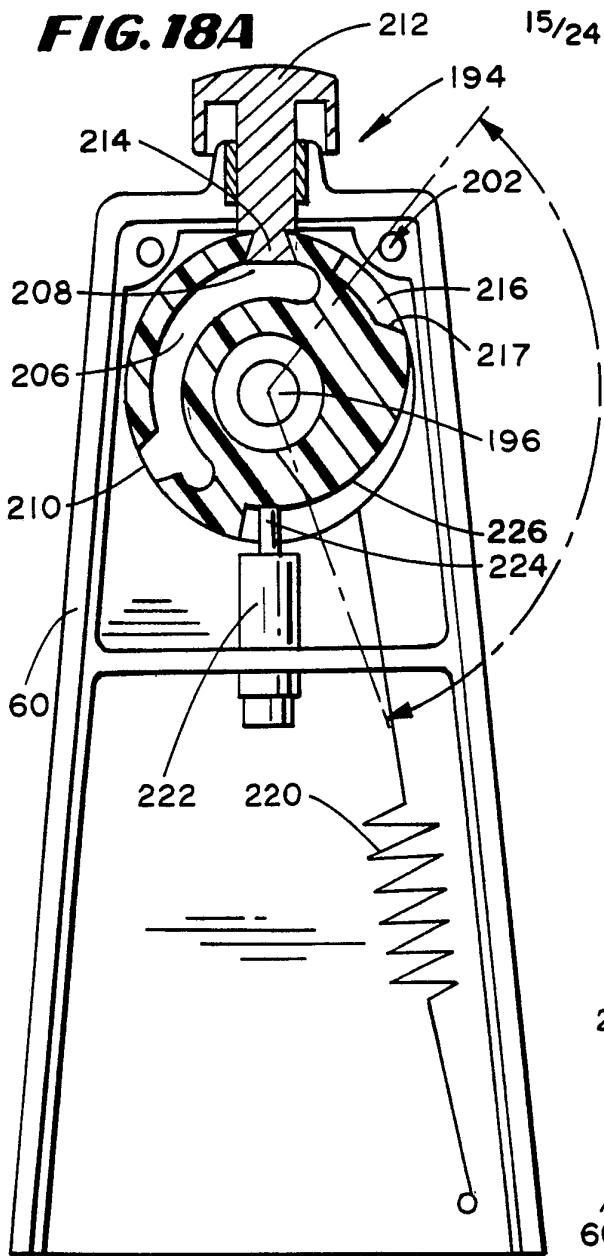
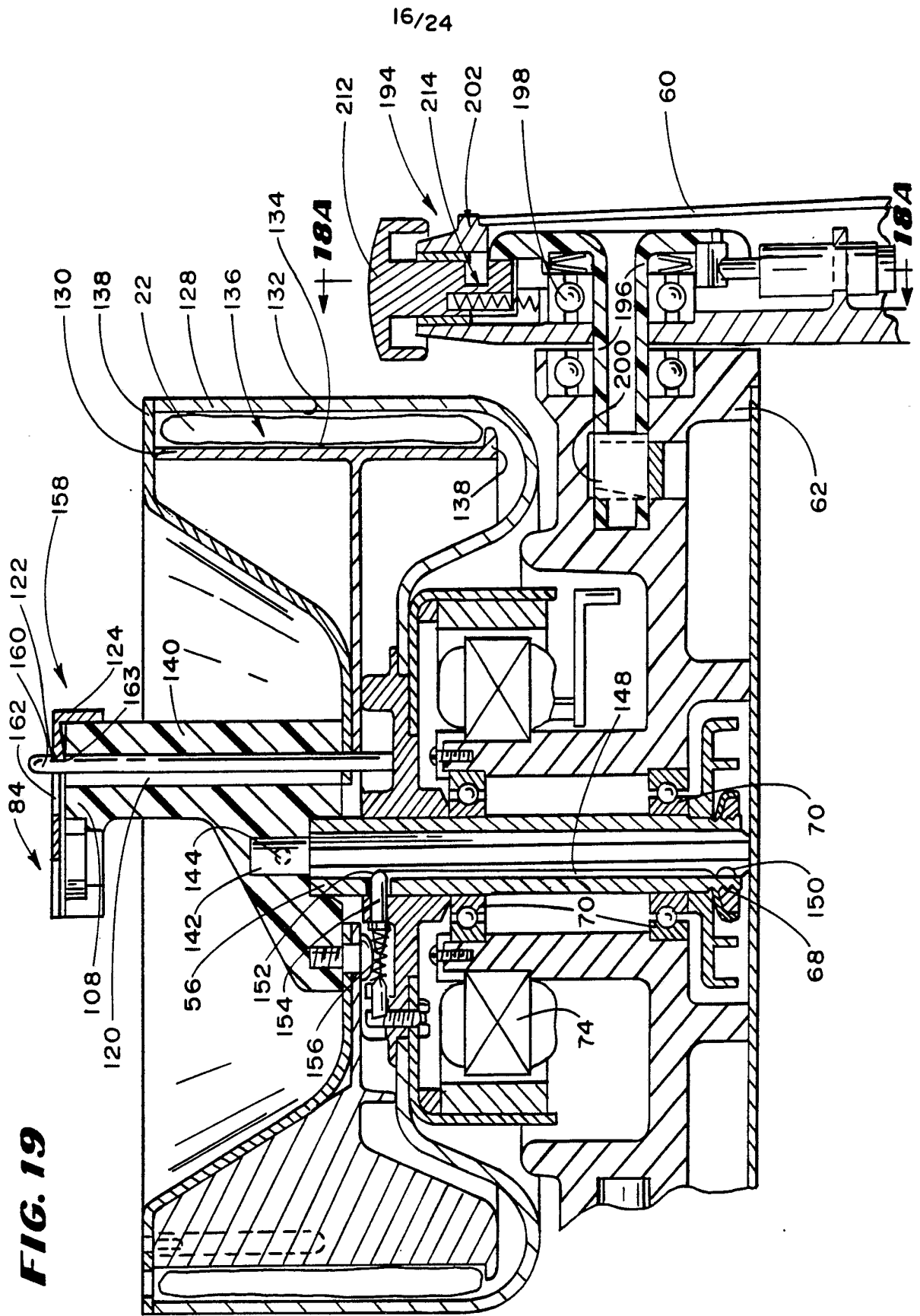

FIG. 19



17/24

FIG. 20

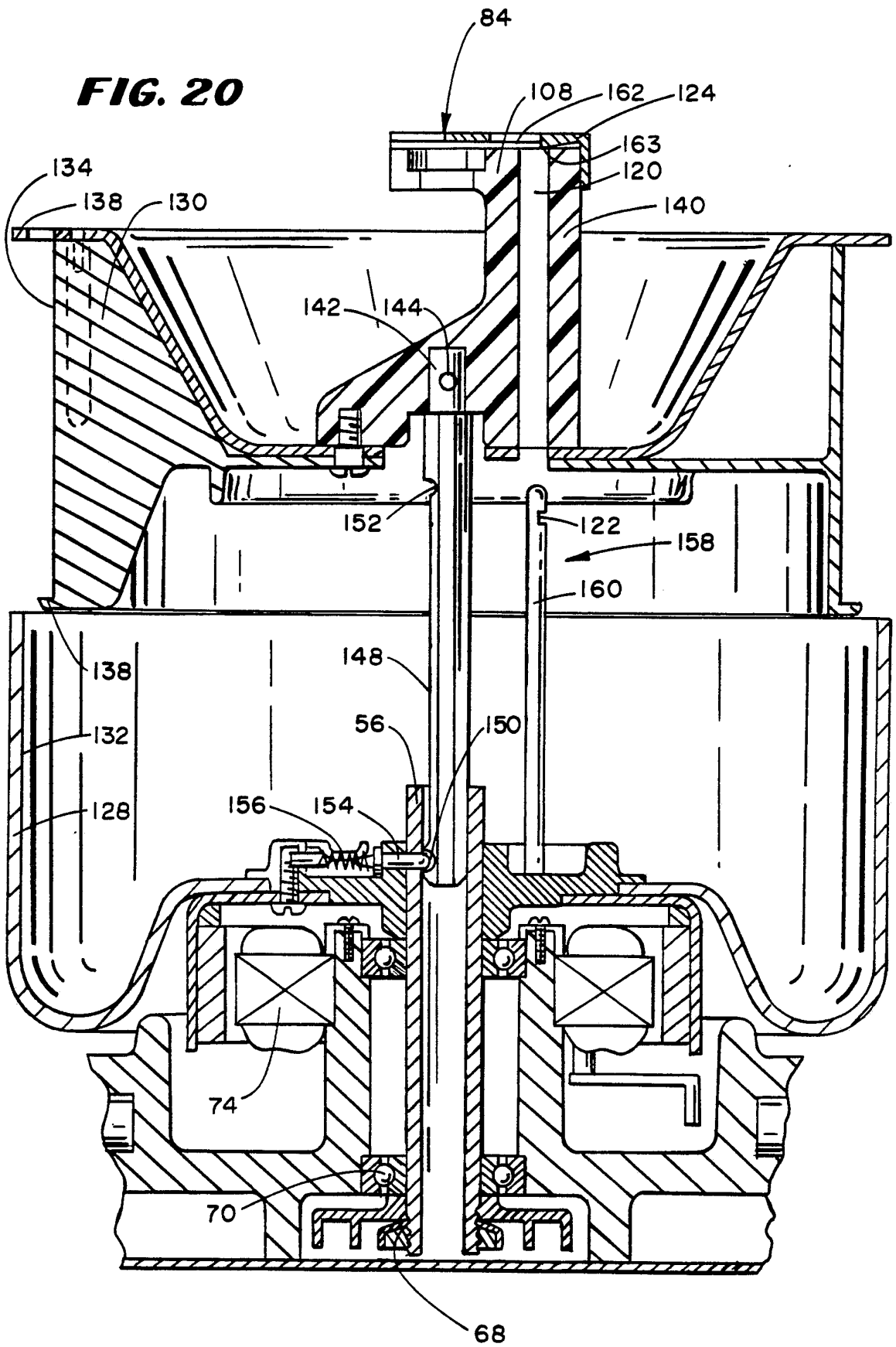

FIG. 23

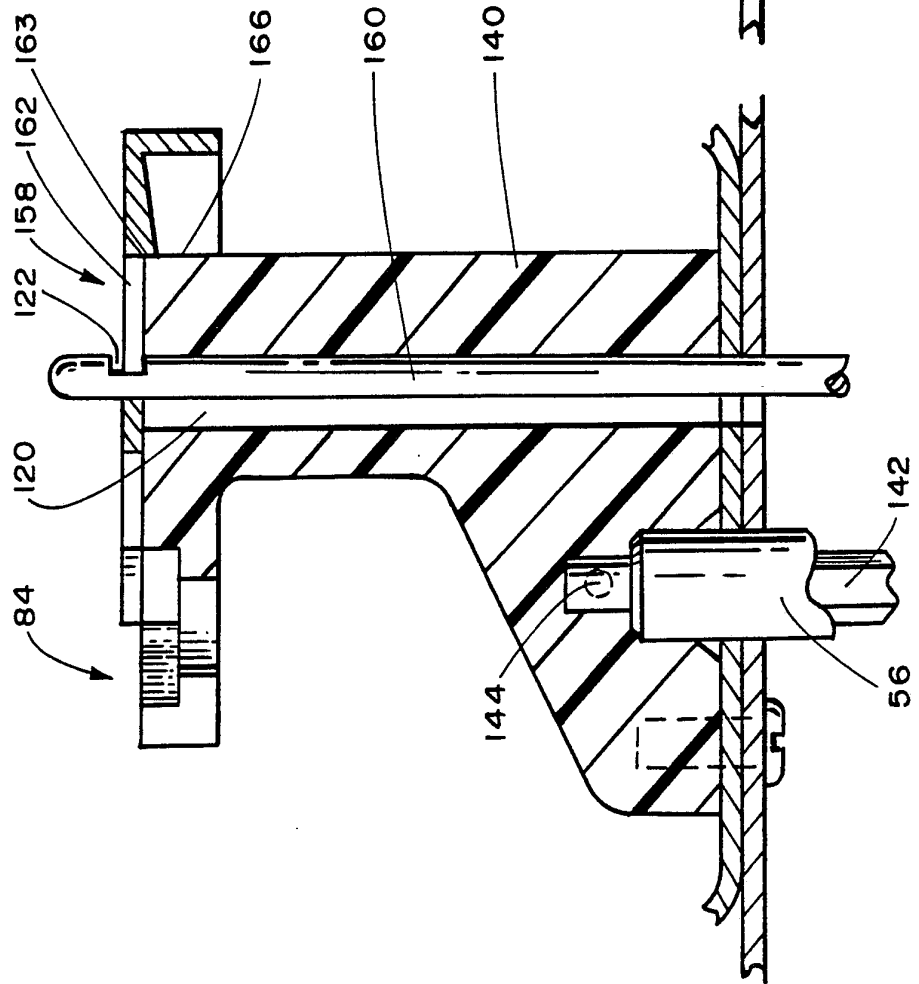
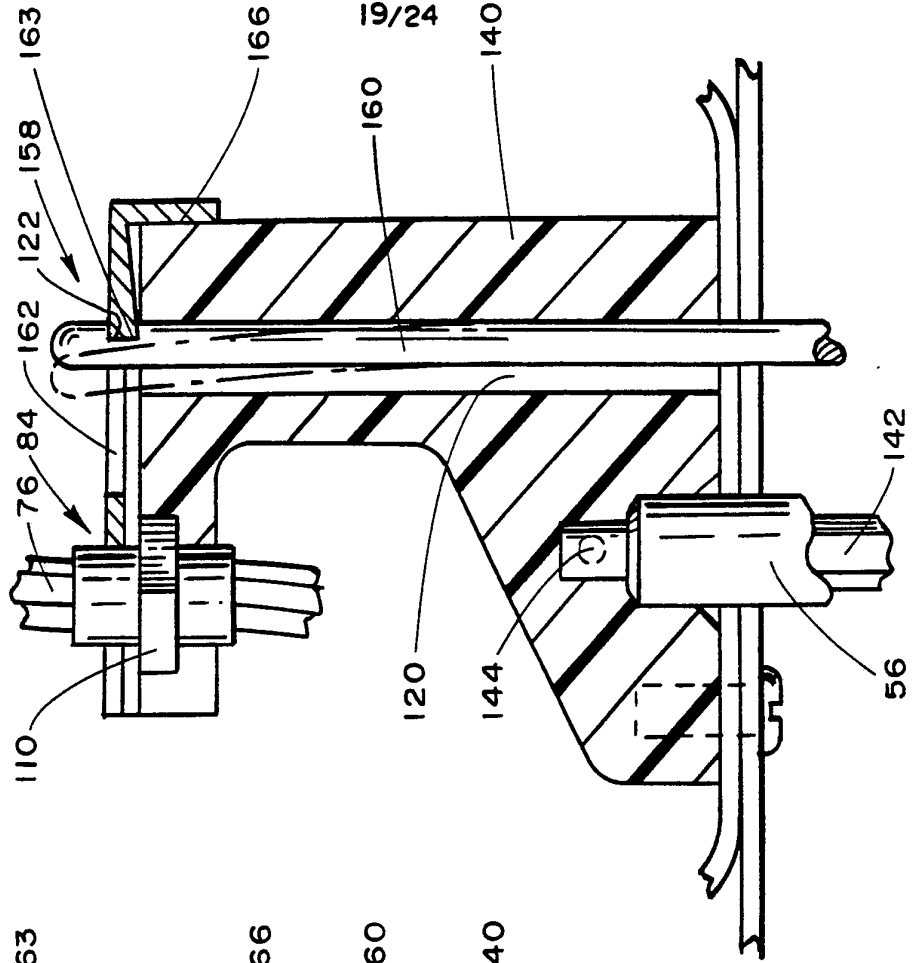

FIG. 24



20/24

FIG. 25

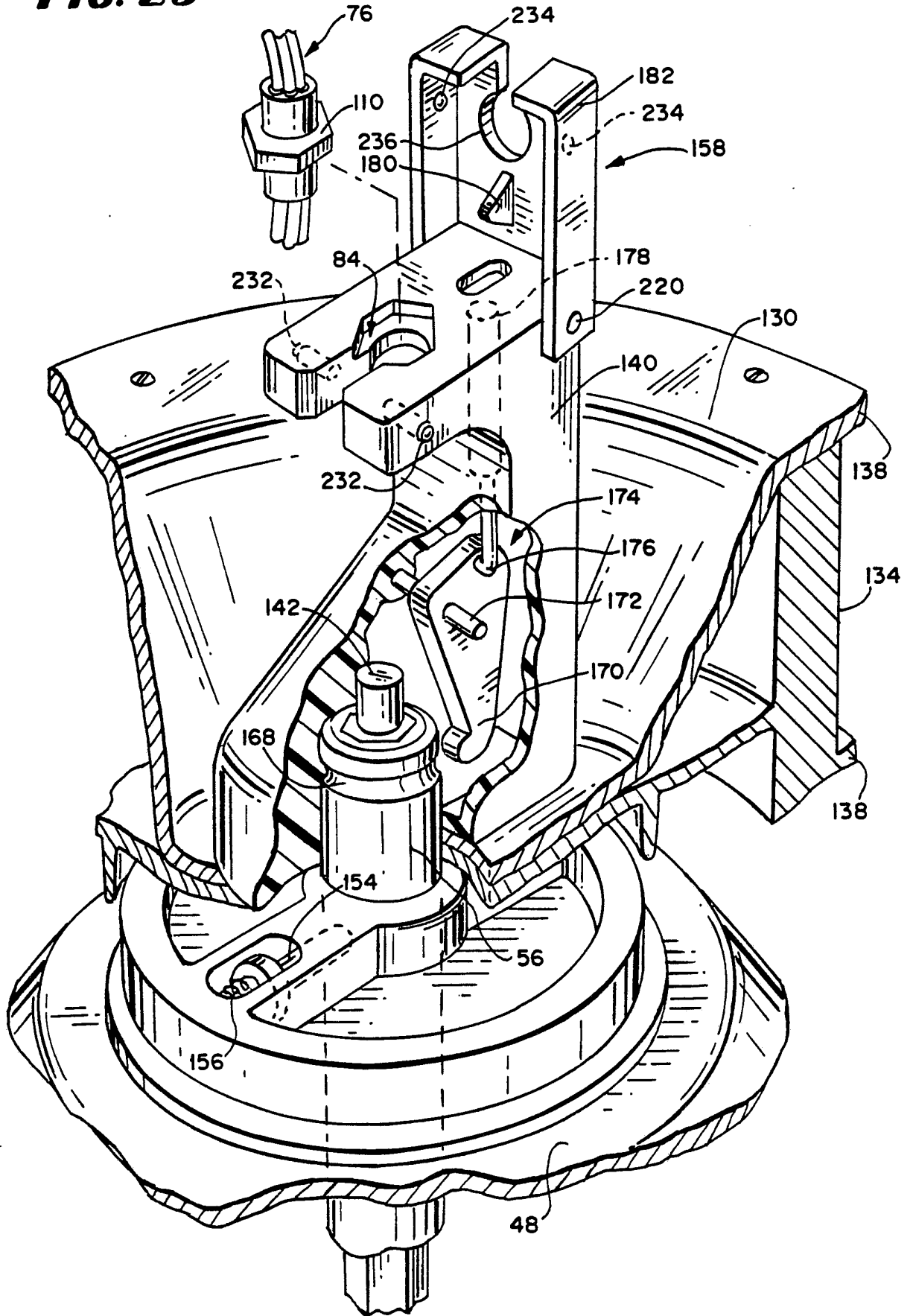

FIG. 26

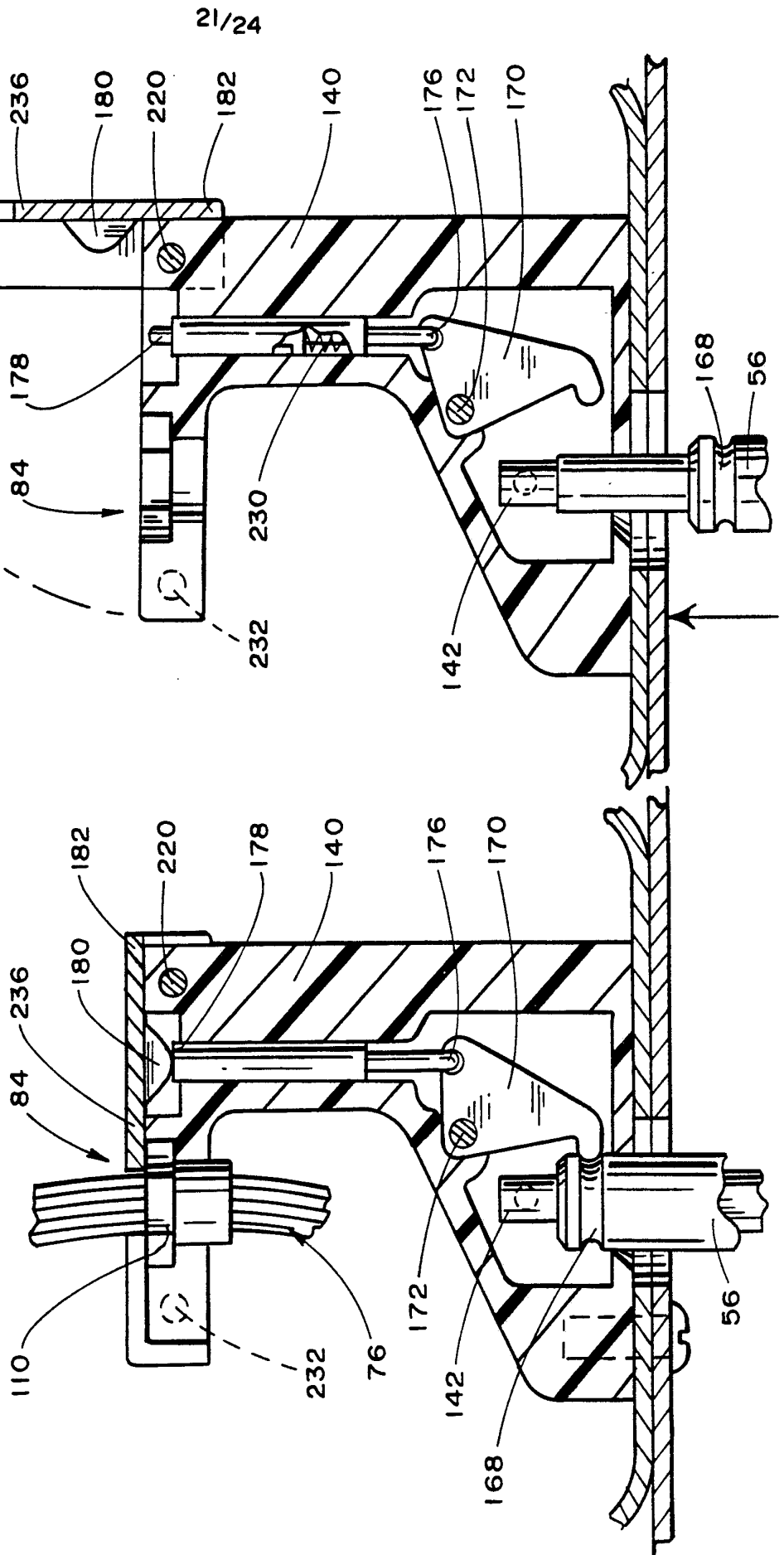
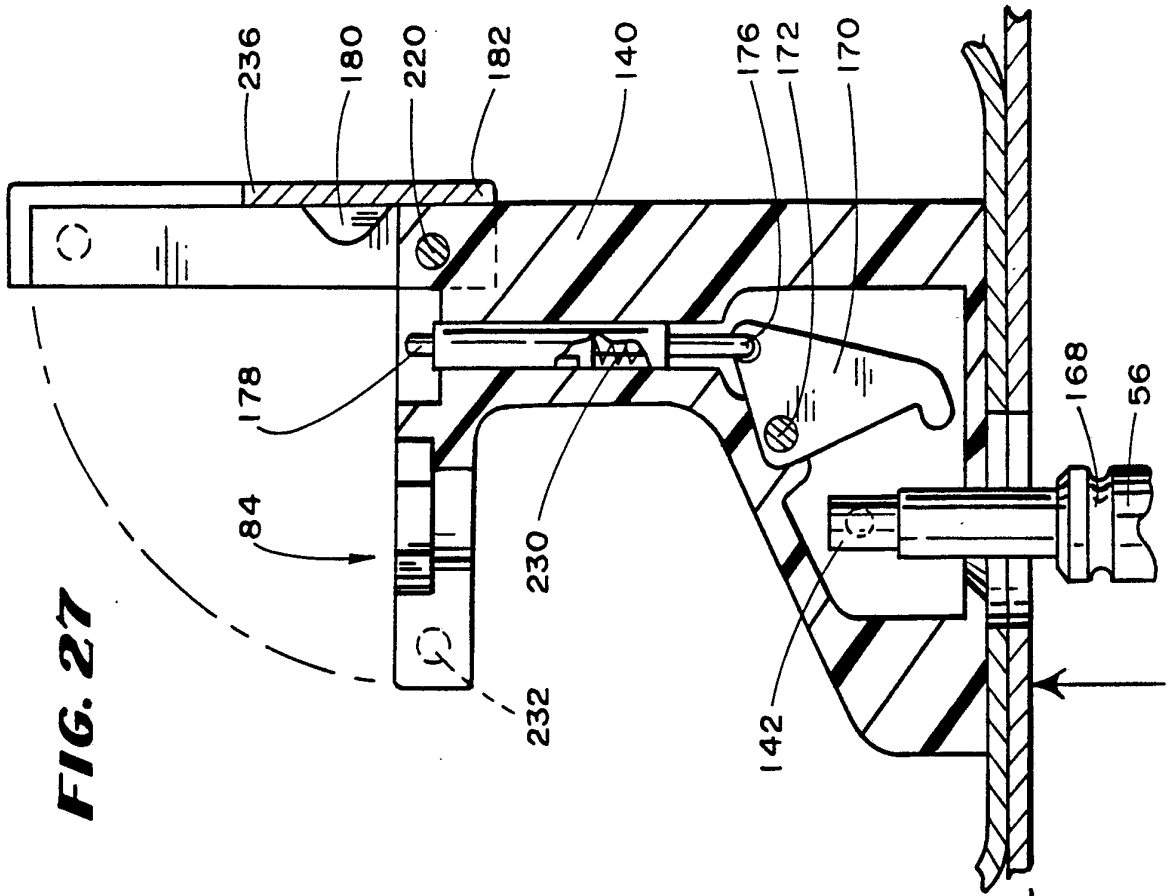

FIG. 27



22/24

FIG. 28

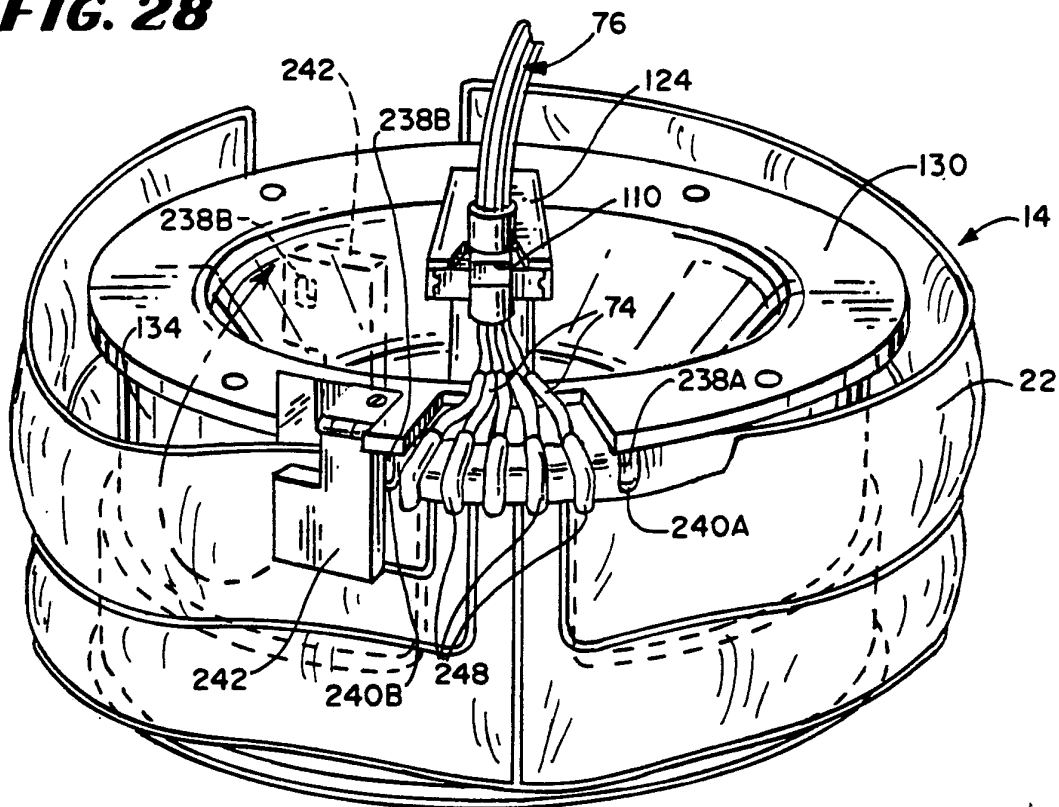
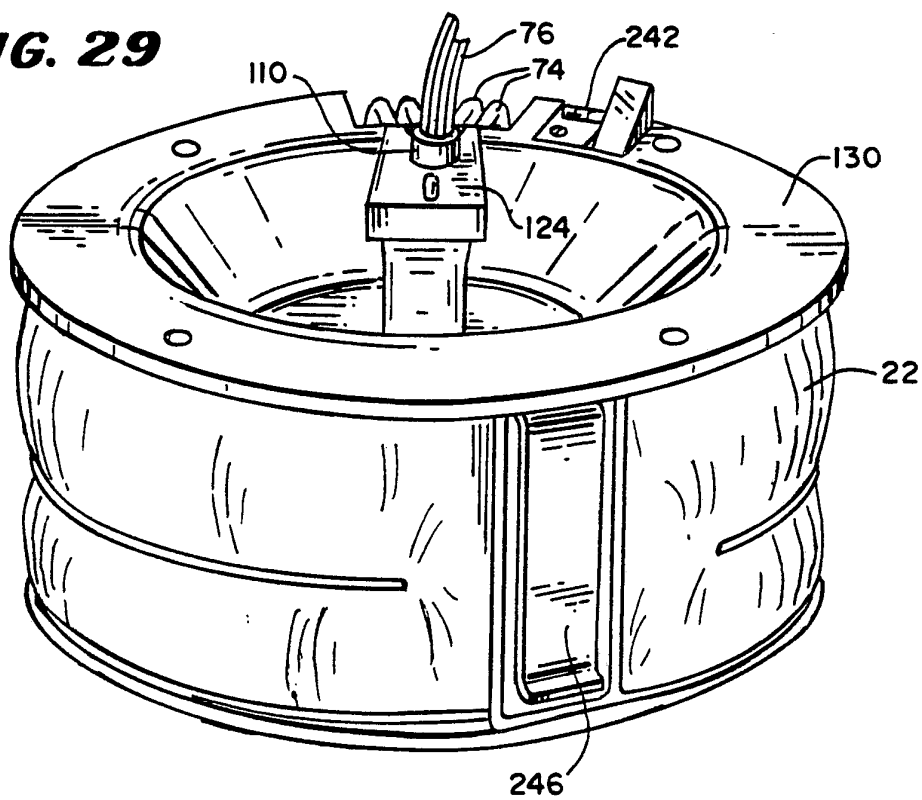

FIG. 29



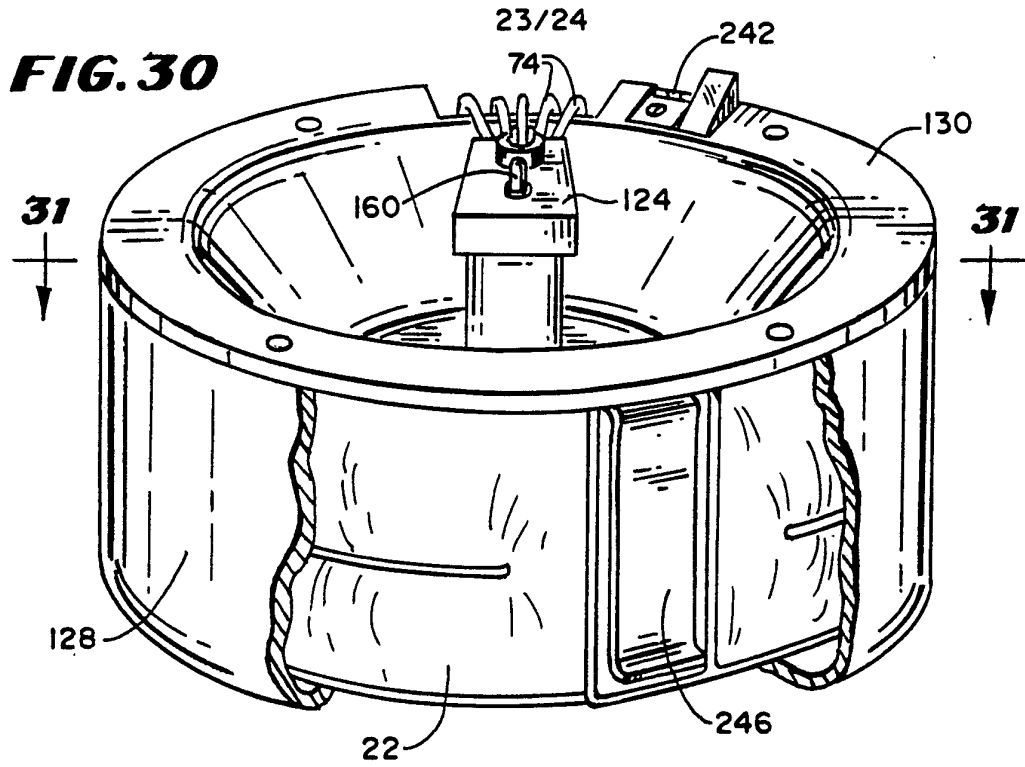

FIG. 31

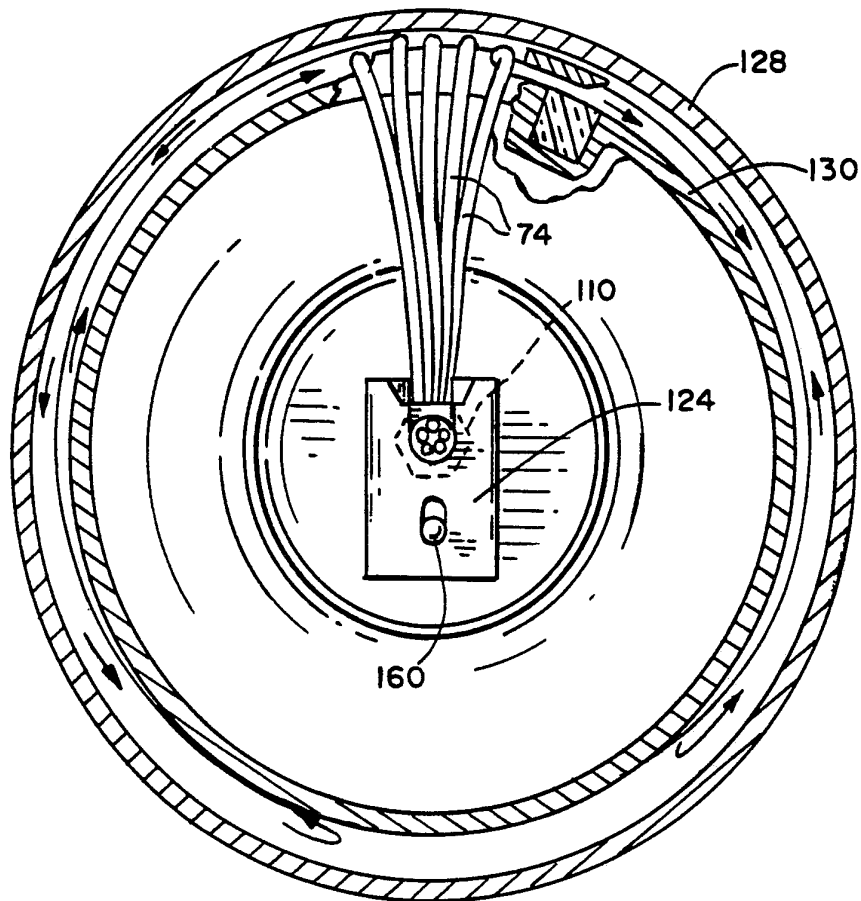
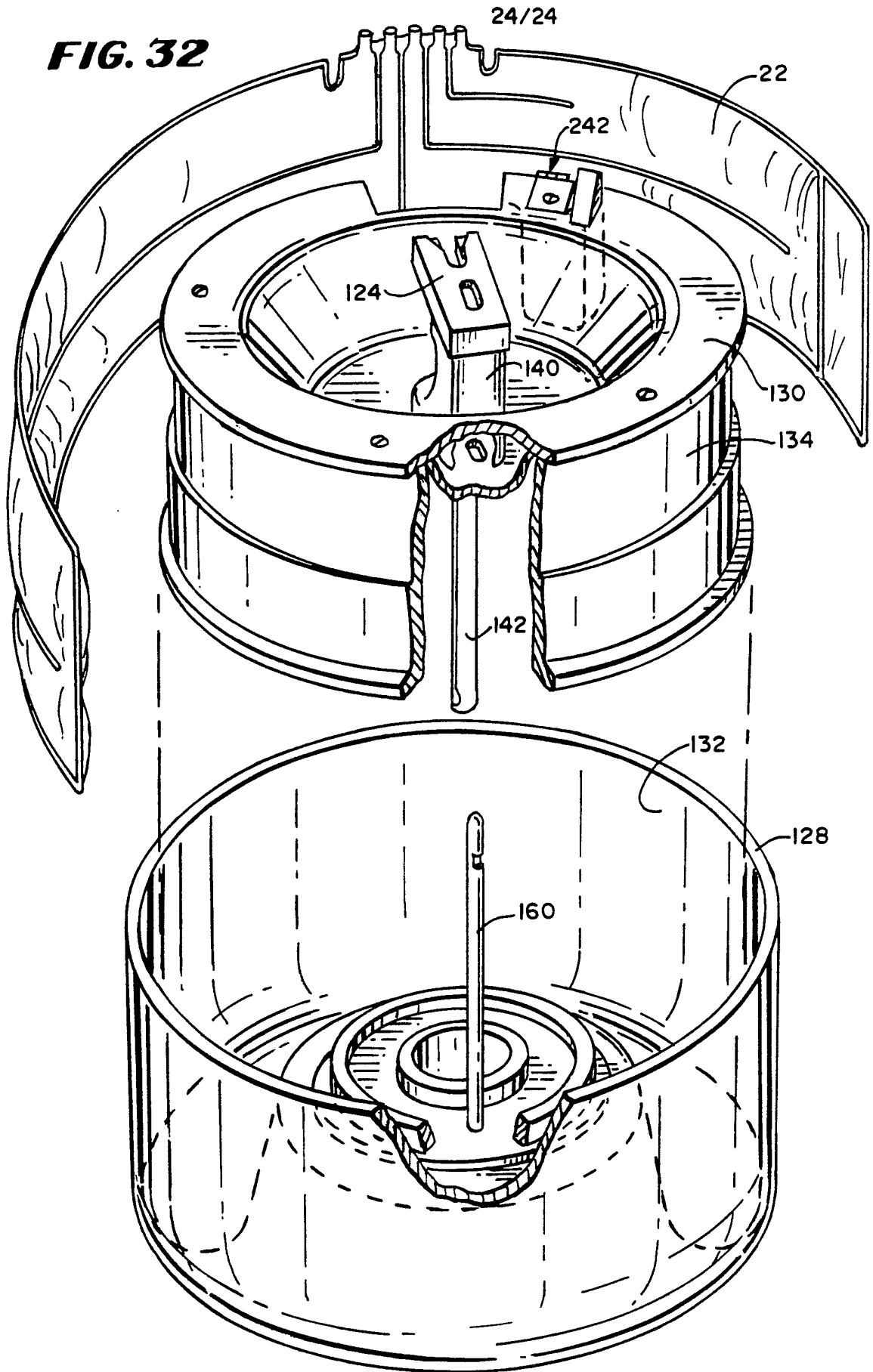

FIG. 32



INTERNATIONAL SEARCH REPORT

PCT/US92/11216

A. CLASSIFICATION OF SUBJECT MATTER IPC(5) :B04B 5/02; 11/00, 9/00 US CL :Please See Extra Sheet. According to International Patent Classification (IPC) or to both national classification and IPC		
B. FIELDS SEARCHED Minimum documentation searched (classification system followed by classification symbols) U.S. : 210/767, 781, 782; 68/23R 23.3, 210; 312/209, 293.1, 330.1; 422/44, 72; 494/12, 16-21 Documentation searched other than minimum documentation to the extent that such documents are included in the fields searched Electronic data base consulted during the international search (name of data base and, where practicable, search terms used)		
C. DOCUMENTS CONSIDERED TO BE RELEVANT		
Category*	Citation of document, with indication, where appropriate, of the relevant passages	Relevant to claim No.
A	US, A, 3,514,171 (MCGAHA) 26 May 1970. See the entire document.	
A	US, A, 4,113,173 (LOLACHI) 12 September 1978. See the entire document.	
A	US, A, 4,114,802 (BROWN) 19 September 1978. See the entire document.	
A	US, A, 4,164,318 (BOGGS) 14 August 1979. See the entire document.	
A	US, A, 4,244,513 (FAYER) 13 January 1981. See the entire document.	
<input checked="" type="checkbox"/> Further documents are listed in the continuation of Box C. <input type="checkbox"/> See patent family annex.		
* "A"	Special categories of cited documents: document defining the general state of the art which is not considered to be part of particular relevance	"T" later document published after the international filing date or priority date and not in conflict with the application but cited to understand the principle or theory underlying the invention
"E"	earlier document published on or after the international filing date	"X" document of particular relevance; the claimed invention cannot be considered novel or cannot be considered to involve an inventive step when the document is taken alone
"L"	document which may throw doubts on priority claim(s) or which is cited to establish the publication date of another citation or other special reason (as specified)	"Y" document of particular relevance; the claimed invention cannot be considered to involve an inventive step when the document is combined with one or more other such documents, such combination being obvious to a person skilled in the art
"O"	document referring to an oral disclosure, use, exhibition or other means	"&" document member of the same patent family
"P"	document published prior to the international filing date but later than the priority date claimed	
Date of the actual completion of the international search 29 JANUARY 1993		Date of mailing of the international search report 09 MAR 1993
Name and mailing address of the ISA/US Commissioner of Patents and Trademarks Box PCT Washington, D.C. 20231 Facsimile No. NOT APPLICABLE		Authorized officer <i>Terrence R. Till</i> TERRENCE R. TILL INTERNATIONAL DIVISION Telephone No. (703) 308-1592

INTERNATIONAL SEARCH REPORT

International application No.
PCT/US92/11216

C (Continuation). DOCUMENTS CONSIDERED TO BE RELEVANT		
Category*	Citation of document, with indication, where appropriate, of the relevant passages	Relevant to claim No.
Y	US, A, 4,283,004 (LAMADRID) 11 August 1981. See the entire document.	3
Y	US, A, 4,535,610 (FEY) 20 August 1985. See the entire document.	1, 2, 4-7
A	US, A, 4,710,161 (TAKABAYASHI) 01 December 1987. See the entire document.	
Y	US, A, 4,936,820 (DENNEHEY) 26 June 1990. See the entire document.	1, 2, 4-7
A	US, A, 5,067,938 (UCHIDA) 26 November 1991. See the entire document.	

INTERNATIONAL SEARCH REPORT

International application No.
PCT/US92/11216

A. CLASSIFICATION OF SUBJECT MATTER:

US CL :

210/767, 781, 782; 68/23R 23.3, 210; 312/209, 293.1, 330.1; 422/44, 72; 494/12, 16-21