

H. C. PRICE.  
WATER COOLER.

APPLICATION FILED NOV. 23, 1901.

NO MODEL.

Fig. 1.

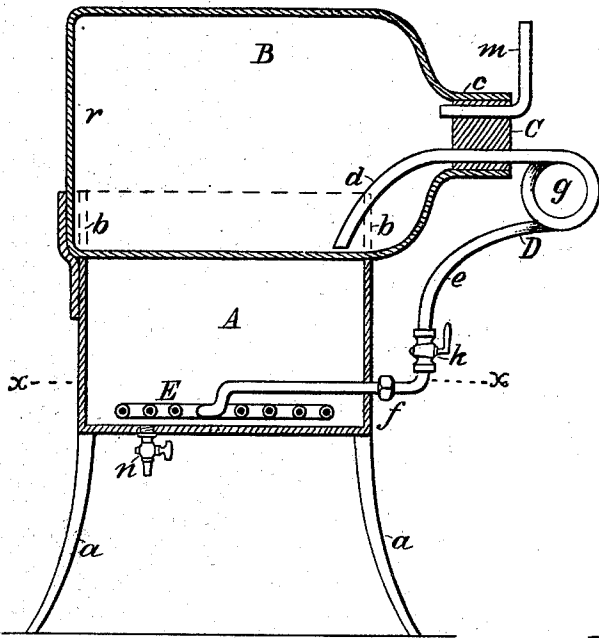

Fig. 2.

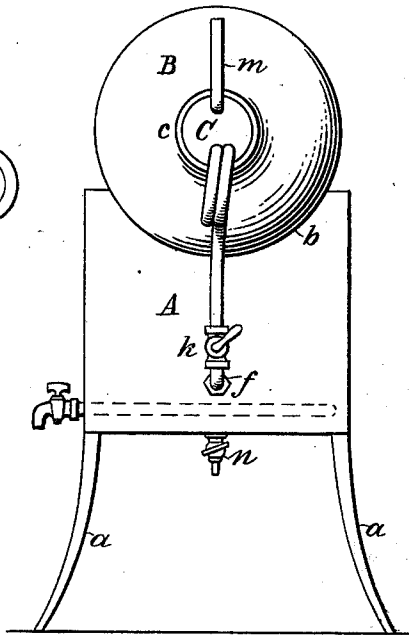
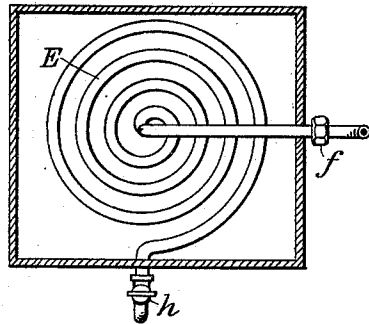

Fig. 3.



WITNESSES:

*Jimmie G. Angus*  
*Daniel S. Dexter*

INVENTOR

*Henry C. Price*

BY

*James A. Whitney*  
 ATTORNEY

# UNITED STATES PATENT OFFICE.

HENRY C. PRICE, OF NEW YORK, N. Y., ASSIGNOR TO SUMNER S. SHEARS,  
OF NEW YORK, N. Y.

## WATER-COOLER.

SPECIFICATION forming part of Letters Patent No. 735,295, dated August 4, 1903.

Application filed November 23, 1901. Serial No. 83,365. (No model.)

*To all whom it may concern:*

Be it known that I, HENRY C. PRICE, a citizen of the United States, and a resident of the borough of Manhattan, in the city and State of New York, have invented certain new and useful Improvements in Fluid-Coolers; and I hereby declare that the following is a full, clear, and exact description of the same, reference being had to the accompanying drawings, constituting a part of this specification.

My object is to provide a construction in which a bottle is used lying on its side, preferably above a cooling-box, through which a discharge-pipe extends to cool the fluid drawn from the bottle by siphonic action. Other advantages will be apparent from the following description.

My invention will be defined in the claims. In the above preferred embodiment of my invention shown in the drawings, Figure 1 is a central vertical section of a side elevation. Fig. 2 is an end elevation, and Fig. 3 is a section on the line *xx* of Fig. 1.

In the above preferred embodiment of my invention, A is a cooling-box adapted to contain a suitable cooling agent—such, for instance, as ice—and which may be supported on legs *a a*. This box at its upper portion is cut out, as shown at *b*, to form a concave saddle adapted to receive an ordinary shaped bottle B, which lies on its side, preferably in the position shown. The bottle has a neck *c*, which in this embodiment is centrally located with respect to the sides of the bottle, and the upper side of the bottle is above the neck, as shown, and in the present embodiment the lower side of the bottle is below the neck.

C is a water-tight cork or closure for the neck.

D is a discharge-pipe extending through the cork into the bottle and having an open end *d* terminating close to the lower side of the bottle, preferably bent downwardly, as shown. The discharge-pipe may also have a coil *g* therein, which may form a water-trap, if desired.

*m* is a vent adapted to admit air to the bottle and having its opening into which the air passes at—that is, substantially at least as high as—the level of the upper side of the bot-

tle when the bottle is lying on its side, so that when the bottle is substantially full of water, no water will run out of this vent. In the present embodiment this vent is a tube projecting through the cork and having its end outside the bottle extending upwardly substantially to the level of the upper side of the bottle.

E is a cooling-pipe located in the box below the bottle and preferably having convolutions therein, as shown, and detachably connected at one end to the discharge-pipe D by the coupling *f*, preferably at a point below the bottle.

*k* is a valve for opening and closing pipe D. *h* is a valved discharge-cock by which the water may be drawn off.

It will be observed that the discharge-pipe formed by the pipes D and E, with the end *d*, form a siphon which does not rise above the upper side of the bottle. In fact, in this embodiment it does not rise above the neck of the bottle. When, therefore, the bottle is laid on its side and the discharge-pipe connected with the cooling-pipe, the siphon will be immediately filled with an "uncharged" fluid, with which the bottle is filled, such as ordinary water, and no water will run out of the vent *m*, as the air is admitted to the vent at—that is, substantially at least as high as—the level of the upper side of the bottle. The valve *k*, being in the discharge-pipe D, will be closed when the bottle is laid on its side, and the coupling *f* may then connect the discharge-pipe with the cooling-pipe, and as soon as the valve *k* is opened the cooling-coil will be immediately filled with water, which will be suitably cooled, and as the discharge-cock *h* at the other end of the cooling-coil is below the bottle the siphon will not be broken until substantially all of the water has been discharged from the bottle.

*n* is a cock in the bottom of the cooling-chamber, by which water formed by the melting of the ice may be drawn off.

I am aware that many variations from the construction illustrated in the drawings may be made without departing from the spirit of my invention, and I therefore do not limit myself to the particular construction heretofore shown and described.

What I claim is—

1. In a cooler for fluids in combination, a cooling-box adapted to contain a cooling agent, a bottle having a neck and lying on its side above said box whereby the upper side of said bottle is above said neck, a water-tight cork or closure for said neck, a discharge-pipe extending through said closure into said bottle and having an open end terminating close to the lower side of said bottle, an open vent-tube in said closure adapted to admit air to said bottle and extending upwardly outside of said bottle and substantially to the level of the upper side thereof, a cooling-pipe located in said box below said bottle and connected at one end to said discharge-pipe and not rising above said bottle whereby said two pipes form a siphon which will be immediately filled by an uncharged fluid filling said bottle, the other end of said cooling-pipe projecting outside of said box below said bottle and provided with a valve for the same.

2. In a cooler for fluids in combination, a cooling-box adapted to contain a cooling agent, a bottle having a neck and lying on its side above said box whereby the upper side of said bottle is above said neck, a water-tight cork or closure for said neck, a discharge-pipe extending through said closure into said bottle and having an open end bent downwardly and terminating close to the lower side of said bottle, an open vent substantially at the level of the upper side of said bottle and adapted to admit air to said bottle, a cooling-pipe located in said box below said bottle and connected at one end to said discharge-pipe and not rising above said bottle whereby said two pipes form a siphon which will be immediately filled by an uncharged fluid filling said bottle, the other end of said cooling-pipe projecting outside of said box below said bottle and provided with a valve for the same.

3. In a cooler for fluids in combination, a cooling-box adapted to contain a cooling agent, a bottle having a neck and lying on its side above said box whereby the upper side of said bottle is above said neck, a water-tight cork or closure for said neck, a discharge-pipe extending through said closure into said bottle and having an open end bent downwardly and terminating close to the lower side of said bottle, an open vent substantially at the level of the upper side of said bottle and adapted to admit air to said bottle, a cooling-pipe located in said box below said bottle and detachably connected at one end to said discharge-pipe and not rising above said bottle, whereby said two pipes form a

siphon which will be immediately filled by an uncharged fluid filling said bottle, a valve in said discharge-pipe adapted to open and close the same, the other end of said cooling-pipe projecting outside of said box below said bottle and provided with a valve for the same.

4. In a cooler for fluids in combination, a cooling-box adapted to contain a cooling agent, a bottle having a neck substantially centrally located with respect to the sides of said bottle and lying on its side above said box whereby the upper side of said bottle is above said neck and the lower side below the same, a water-tight cork or closure for said neck, a discharge-pipe extending through said closure into said bottle and having an open end bent downwardly and terminating close to the lower side of said bottle, an open vent-tube in said closure adapted to admit air to said bottle and extending upwardly outside of said bottle and substantially to the level of the upper side thereof, a cooling-pipe having convolutions located in said box below said bottle and detachably connected at one end to said discharge-pipe outside of said box and not rising above said bottle, whereby said two pipes form a siphon which will be immediately filled by an uncharged fluid filling said bottle, a valve in said discharge-pipe adapted to open and close the same, the other end of said cooling-pipe projecting outside of said box below said bottle and provided with a valve for the same.

5. In a cooler for fluids in combination, a cooling-box adapted to contain a cooling agent, a bottle having a neck and lying on its side adjacent said box whereby the upper side of said bottle is above said neck and the lower side below the same, a water-tight cork or closure for said neck, an open vent-tube in said closure adapted to admit air to said bottle and extending upwardly outside said bottle and substantially to the level of the upper side thereof, a discharge-pipe extending through said closure into said bottle and having an open end bent downwardly and terminating close to the lower side of said bottle, the other end of said pipe outside said bottle being bent downwardly and extending below said bottle whereby it forms a siphon which will be immediately filled by an uncharged fluid filling said bottle, said discharge-pipe being provided with a valve outside and below said bottle for opening and closing said pipe.

HENRY C. PRICE.

Witnesses:

DANIEL S. DECKER,  
JENNIE G. ANGUS.