

INSTRUCTIONS

(a) If Convention application insert "Convention"

(a) Convention

AUSTRALIA

600385

Patents Act

(b) Delete one

APPLICATION FOR A STANDARD/~~PETTY~~ (b) PATENT

(c) Insert FULL name(s) of applicant(s)

We (c) HOOGOVENS GROEP B.V.

APPLICATION ACCEPTED AND AMENDMENTS ALLOWED 29.5.90

(d) Insert FULL address(es) of applicant(s)

of (d) P.O. Box 10.000
1970 CA IJMUIDEN
The Netherlands

(e) Delete one

hereby apply for the grant of a (e) Standard/~~Petty~~ Patent for an invention entitled

(f) Insert TITLE of invention

(f) CERAMIC GAS BURNER FOR A COMBUSTION CHAMBER OF A HOT-BLAST STOVE

(g) Insert "complete" OR "provisional" OR "petty patent"

which is described in the accompanying (g) complete specification.

(Note: The following applies only to Convention applications)

Details of basic application(s)

(h) Insert number, country and filing date for the/or EACH basic application

Application No.	Country	Filing Date
NL 8702036	The Netherlands	August 31, 1987

Address for Service:

PHILLIPS ORMONDE AND FITZPATRICK
Patent and Trade Mark Attorneys
367 Collins Street
Melbourne, Australia 3000

(i) Insert DATE of signing

Dated (i) July 11, 1988

(j) Signature of applicant(s) (for body corporate see headnote*)

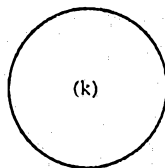

(j)

Ir. B. Zuidema, patent counsel

(k) Corporate seal if any

Note: No legalization other witness required

PHILLIPS ORMONDE AND FITZPATRICK
Patent and Trade Mark Attorneys
367 Collins Street
Melbourne, Australia

AUSTRALIA

Patents Act

DECLARATION FOR A PATENT APPLICATION

INSTRUCTIONS

(a) Insert "Convention" if applicable
(b) Insert FULL name(s) of applicant(s)

In support of the (a) Convention application made by (b) HOOGOVENS GROEP B.V.

(c) Insert "of addition" if applicable
(d) Insert TITLE of invention

(hereinafter called "applicant(s)" for a patent (c) for an invention entitled (d) CERAMIC GAS BURNER FOR A COMBUSTION CHAMBER OF A HOT-BLAST STOVE

(e) Insert FULL name(s) AND address(es) of declarant(s) (See headnote*)

1/We (e) Ir. B. Zuidema - Patent Counsel HOOGOVENS GROEP B.V. P.O. Box 10.000 1970 CA IJMUIDEN The Netherlands

do solemnly and sincerely declare as follows:

xxxxxx/We are the applicant(s)
xxxxxx/We are the applicant(s) of the invention

1. I am/We are authorized to make this declaration on behalf of the applicant(s).

xxxxxx/We are the actual inventor(s) of the invention
xxxxxx/We are the actual inventor(s) of the invention

(f) Insert FULL name(s) AND address(es) of actual inventor(s)

2. (f) Jacob Felthuis and Ronald Johannes Maria Stokman Honthorstlaan 4 Albert Verweylaan 109 1816 TB ALKMAAR 2182 PV HILLEGOM The Netherlands The Netherlands

xx/are the actual inventor(s) of the invention and the facts upon which the applicant(s) xx/are entitled to make the application are as follows:

(g) Recite how applicant(s) derive(s) title from actual inventor(s) (See headnote**)

(g) The applicant is the assignee of the invention from the actual inventors.

(Note: Paragraphs 3 and 4 apply only to Convention applications)

(h) Insert country, filing date, and basic applicant(s) for the/or EACH basic application

3. The basic application(s) for patent or similar protection on which the application is based is/are identified by country, filing date, and basic applicant(s) as follows:

(h) The Netherlands, No. 8702036 filed August 31, 1987 by HOOGOVENS GROEP B.V.

4. The basic application(s) referred to in paragraph 3 hereof was/were the first application(s) made in a Convention country in respect of the invention the subject of the application.

(k) Insert PLACE of signing

Declared at (k) IJmuiden

(l) Insert DATE of signing

Dated (l) Jul., 11, 1988

(m) Signature(s) of declarant(s)

(m) [Signature] Ir. B. Zuidema

Note: No legalization or other witness required

To: The Commissioner of Patents

Patent counsel

(12) PATENT ABRIDGMENT (11) Document No. AU-B-21195/88
(19) AUSTRALIAN PATENT OFFICE (10) Acceptance No. 600385

(54) Title
CERAMIC GAS BURNER FOR A COMBUSTION CHAMBER OF A HOT-BLAST STOVE
OF A HOT BLAST FURNACE

International Patent Classification(s)
(51)^s F23D 014/22

(21) Application No. : 21195/88 (22) Application Date : 22.08.88

(30) Priority Data

(31) Number (32) Date (33) Country
8702036 31.08.87 NL NETHERLANDS

(43) Publication Date : 02.03.89

(44) Publication Date of Accepted Application : 09.08.90

(71) Applicant(s)
HOOGOEVENS GROEP B.V.

(72) Inventor(s)
JACOB FELTHUIS; RONALD JOHANNES MARIA STOKMAN

(74) Attorney or Agent
PHILLIPS, GRMONDE & FITZPATRICK

(56) Prior Art Documents
US 4259064
US 4353688
US 3627284

(57) Claim

1. A ceramic gas burner for a combustion chamber of a hot-blast stove having parallel vertical supply ducts for the two combustion components, a first one of said ducts having an upwardly opening first outlet opening which has in plan view a substantially rectangular shape with two long sides and the second of said ducts opening at a plurality of second outlet openings which are located on both sides of and above said first outlet opening, the general discharge directions of the second outlet openings being oblique to that of the first outlet opening, wherein as seen in plan view the first outlet opening has, in its long sides, a plurality

(11) AU-B-21195/88
(10) 600385

-2-

of recesses which extend outwardly towards the second outlets said recesses being arranged so that, with respect to each said recess in a first one of said long sides of the first outlet opening, there is correspondingly a said recess directly opposite in the second of said long sides of the first outlet opening.

CERAMIC GAS BURNER FOR A COMBUSTION CHAMBER OF A
HOT-BLAST STOVE

BACKGROUND OF THE INVENTION

5 1. FIELD OF THE INVENTION

The invention relates to a ceramic gas burner for a combustion chamber of a hot-blast stove, e.g. a hot-blast stove of a blast furnace.

2. DESCRIPTION OF THE PRIOR ART

10 A burner of this type is described in EP-A-90096 which has parallel vertical supply ducts for the two combustion components (gas and air). A first one of these ducts opens upwardly at a first outlet opening which in plan view is essentially
15 rectangular in shape, while the second duct opens at second outlet openings which are on each side of and above the first outlet opening. The outflow directions of the second outlet openings are oblique to that of the first outlet opening.

20 In the long sides of its first outlet opening this burner has a plurality of recesses extending outwardly towards the second outlet openings. These recesses are provided for alternate second outlet openings on each long side of the first outlet
25 opening. The recesses on the two long sides of the

first outlet openings are staggered, so that no recess on one long side is opposite a recess on the other long side.

5 In burners for hot-blast stoves it is important that no combustible components from the combustion gas remain unburnt, or that scarcely any such combustible components remain unburnt. On the other hand it is desirable to reduce the excess of air required for combustion in order to achieve as high as possible a flame temperature at a specific calorific value of the combustion gas. It is known that improving the mixing of gas and air helps to achieve these objectives.

10 The object of the invention is to improve the mixing of the gaseous components in the burner of EP-A-0090096. Other advantages may be achieved, which will be explained in the following.

15 The ceramic burner in accordance with the invention is characterised in that, with respect to each recess in a first one of the long sides of the first outlet opening, there is correspondingly one recess directly opposite in the second long side of the first outlet opening.

20 It is preferable that for each of the second outlet openings of the burner, there is

correspondingly one of the recesses.

This particularly simply shaped burner achieves a very intensive mixture at many places along the long sides of the first outlet opening, which, by lowering the point where the turbulence generated is complete, leads to a more stable flame and lower quantities of unburnt combustible component remaining.

A particular advantage is obtained with the burner in accordance with the invention, if it is constructed from a pack of shaped bricks. Through the greater regularity of the shape of the burner in accordance with the invention, it has been found possible to achieve considerable savings, e.g. of up to 80%, in the number of different shaped bricks used.

It is advantageous if the recesses, as seen in the outflow direction, have outwardly widening cross sections. Preferably this widening is in the direction perpendicular to the long sides of the first outlet opening.

BRIEF INTRODUCTION OF THE DRAWING

The invention will be now illustrated by way of non-limitative example with reference to the accompanying drawing which shows an embodiment and

in which:-

Fig. 1 shows the head of a ceramic burner embodying the invention in plan view; and

Fig. 2 shows a cross-section on the line II-II in Fig. 1.

DESCRIPTION OF THE PREFERRED EMBODIMENT

The location and operation of the burner in the combustion chamber of a hot-blast stove for a blast furnace is well known and does not need to be explained in detail here. Reference is made for example to EP-A-90096.

Referring to Figs. 1 and 2, combustion gas is fed through a central supply duct 1 in the burner head 6, the gas flowing out into a combustion shaft of the hot-blast stove at the outlet opening 3. In plan view, the outlet opening 3 has a rectangular slot shape, with two long sides. Two boundary surfaces 10 (see Fig. 2) of the burner head extend outwardly and upwardly at an angle from the outlet opening 3 to join the walls 11 of the combustion chamber which are partly shown in Fig. 2 but not in Fig. 1.

On both sides of supply duct 1 there are two air supply ducts 2, parallel to the central duct 1.

The ducts 2 communicate through oblique duct portions 4 with a plurality of second outlet openings 5. These second outlet openings 5 form two rows, respectively adjacent each long side of the first outlet opening 3.

The duct portions 4 extend through the burner head 6 which is built into the combustion chamber 11, and which is further bounded by the surfaces 10. In the long side walls of supply duct 1, there are recesses 7 in the form of grooves of square section, which continue into correspondingly shaped recesses or grooves 9 in the burner head 6. The grooves 9 extend into the duct portions 4 at the position of the outlet openings 5. At the position of outlet opening 3 of supply duct 1, the recesses 7 form square recesses 8 in this outlet opening 3 as seen in plan view. As seen in Fig. 1, adjacent each of the second outlet openings 5, there is a recess 8 formed by grooves 7 and 9 in the long side of the outlet opening 3.

Combustion air from the outlets 5 does not blow through the central gas flow, but flows towards it and alongside it.

The grooves 7 widen in the outflow direction towards the outlet opening 3 of the duct 1. This

6.

widening is achieved by an increase of the dimension of the groove 7 perpendicular to the long side of the opening 3.

5 This all leads to a lowering of the point where the turbulence is complete, which produces a very stable flame and a very even and complete combustion of the combustion gas.

THE CLAIMS DEFINING THE INVENTION ARE AS FOLLOWS:

1. A ceramic gas burner for a combustion chamber of a hot-blast stove having parallel vertical supply ducts for the two combustion components, a first one
5 of said ducts having an upwardly opening first outlet opening which has in plan view a substantially rectangular shape with two long sides and the second of said ducts opening at a plurality of second outlet openings which are located on both
10 sides of and above said first outlet opening, the general discharge directions of the second outlet openings being oblique to that of the first outlet opening, wherein as seen in plan view the first outlet opening has, in its long sides, a plurality
15 of recesses which extend outwardly towards the second outlets said recesses being arranged so that, with respect to each said recess in a first one of said long sides of the first outlet opening, there is correspondingly a said recess directly opposite
20 in the second of said long sides of the first outlet opening.

2. A ceramic gas burner according to claim 1, wherein for each of said second outlet openings in the burner there is correspondingly one of said
25 recesses.

8.

3. A ceramic gas burner according to claim 1 wherein in the outflow direction said recesses have widening cross sections.

5 4. A ceramic gas burner according to claim 3 wherein the widening of the cross sections of the recesses occurs by increase of the recess width in the direction perpendicular to the respective long side of the first outlet opening.

DATED: 17 August 1988

PHILLIPS ORMONDE & FITZPATRICK
Attorneys for:
HOOGOEVENS GROEP B.V.

A handwritten signature or stamp, possibly in ink, located below the typed text. It appears to be a stylized name or initials, possibly 'H. J. A. van der...'.

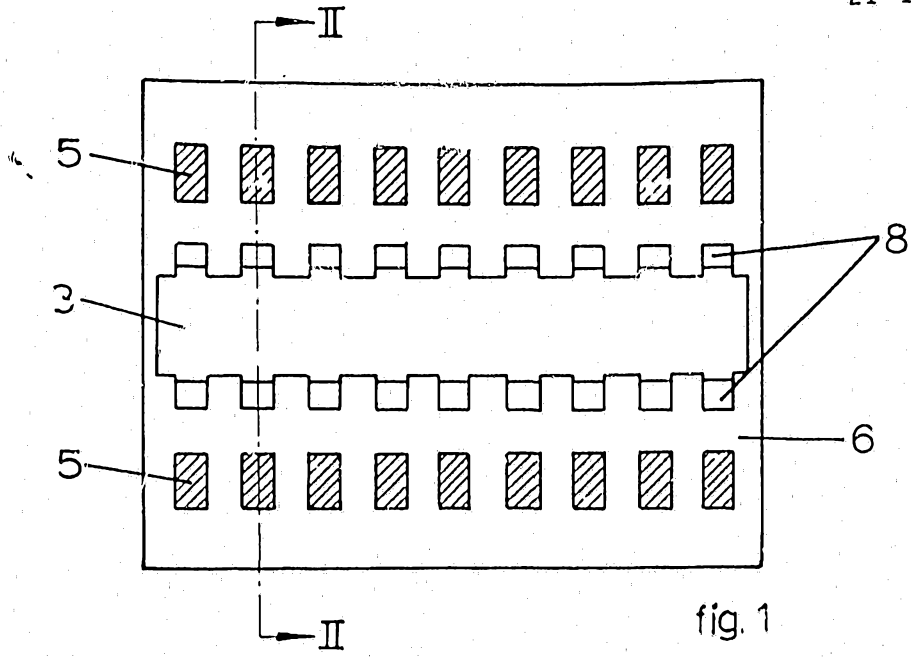

fig. 1

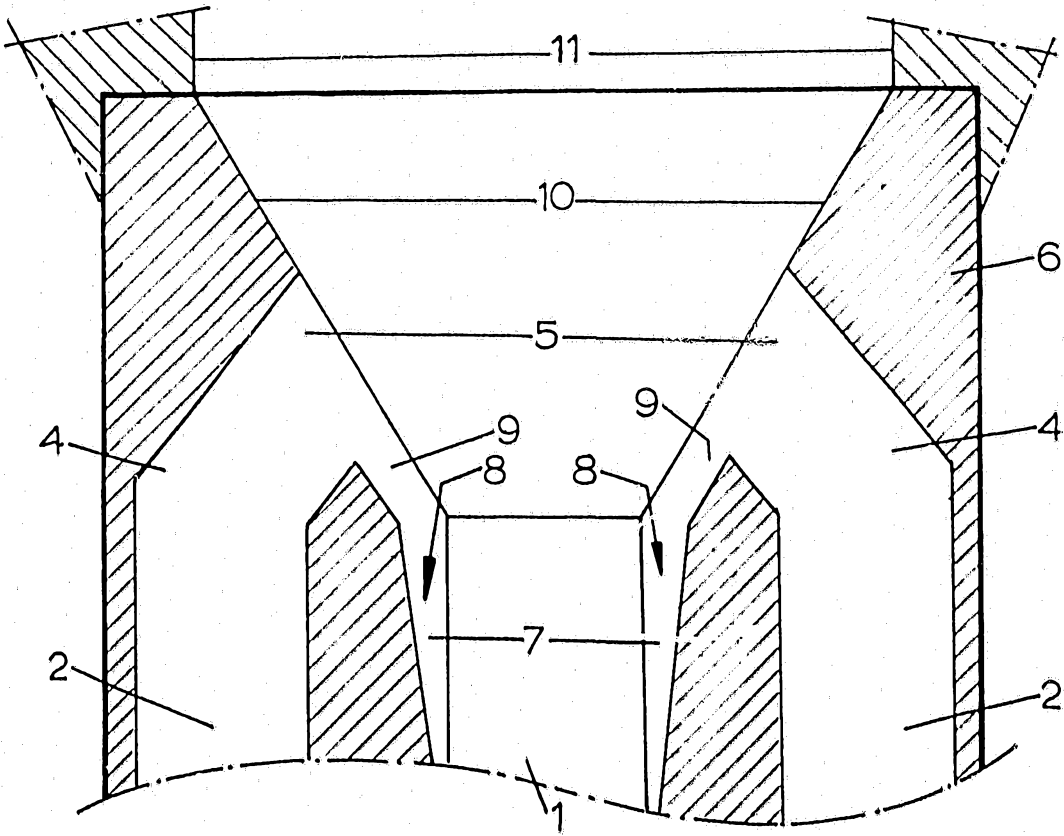

fig. 2