

M. GILMORE.

FIRE ESCAPE.

APPLICATION FILED MAY 6, 1911.

1,001,264.

Patented Aug. 22, 1911.

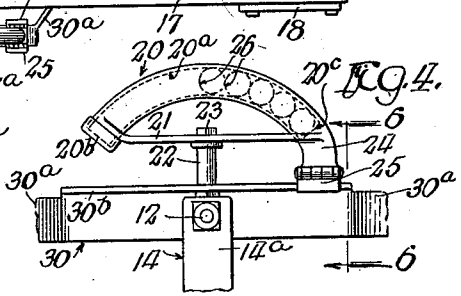
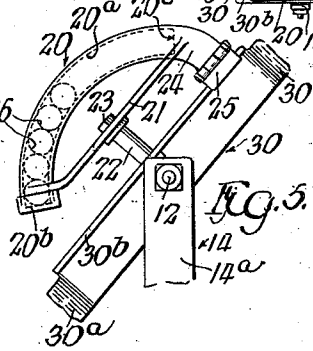
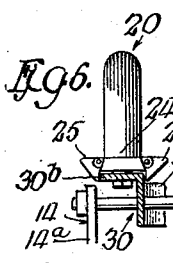
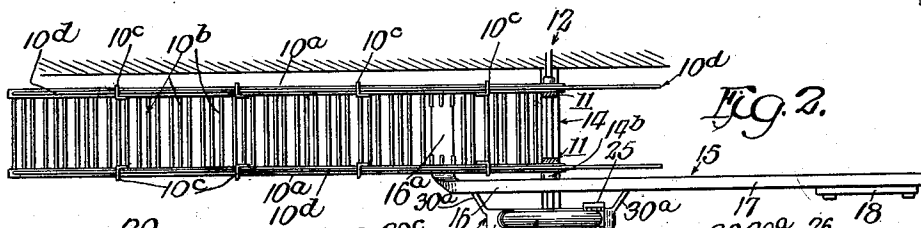
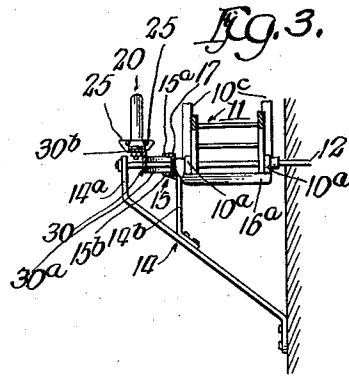
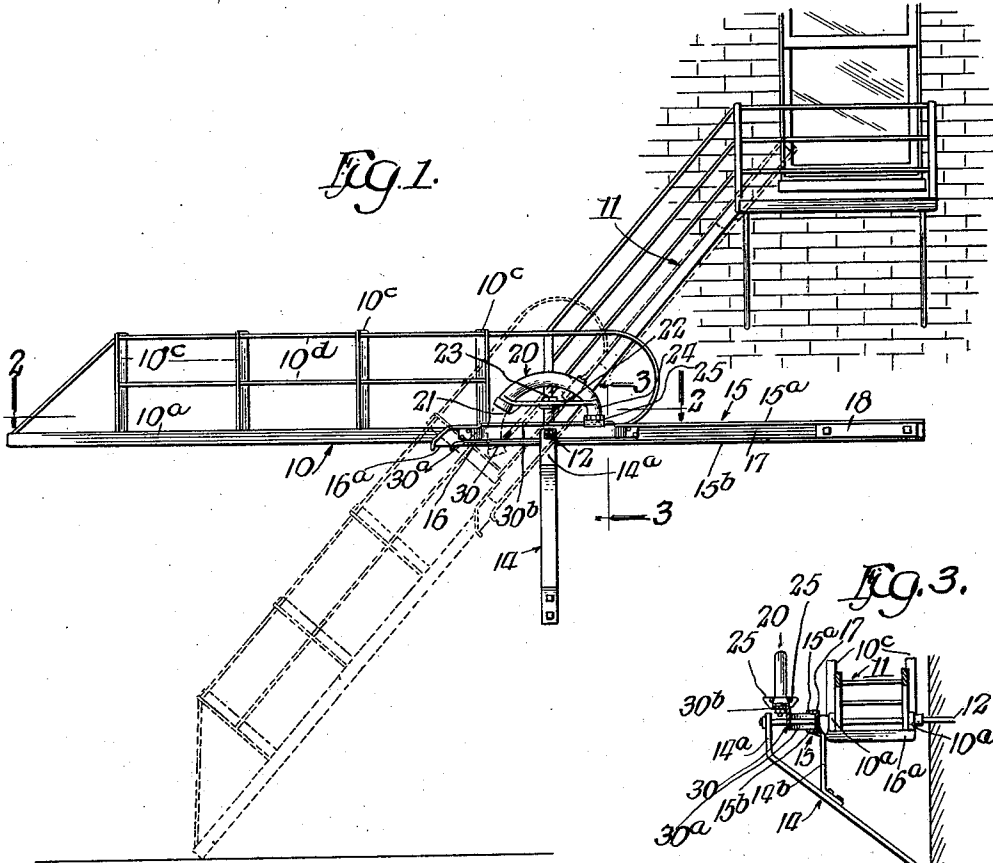

Witnesses:
 J. H. Alford
 H. R. Wilkins

Inventor:
 Millard Gilmore
 by Perk & Brown Attys

UNITED STATES PATENT OFFICE.

MILLARD GILMORE, OF CHICAGO, ILLINOIS, ASSIGNOR TO VARIETY MANUFACTURING COMPANY, OF CHICAGO, ILLINOIS, A CORPORATION OF ILLINOIS.

FIRE-ESCAPE.

1,001,264.

Specification of Letters Patent. Patented Aug. 22, 1911.

Application filed May 6, 1911. Serial No. 625,506.

To all whom it may concern:

Be it known that I, MILLARD GILMORE, a citizen of the United States, and a resident of Chicago, in the county of Cook and State of Illinois, have invented certain new and useful Improvements in Fire-Escapes; and I do hereby declare that the following is a full, clear, and exact description thereof, reference being had to the accompanying drawings, and to the letters of reference marked thereon, which form a part of this specification.

This invention relates to improvements in counterbalanced stairs or ladders more particularly adapted for use in connection with fire escapes, and consists of the matters hereinafter described and more particularly pointed out in the appended claims.

In the drawings—Figure 1 is a view representing a side elevation of my improved counterweighted stairway or ladder; Fig. 2 is a view representing a horizontal section through the same in a plane indicated by the line 2—2 of Fig. 1; Fig. 3 is a view representing a vertical, transverse section through the ladder or stair in a plane indicated by the line 3—3 of Fig. 1; Fig. 4 is a view representing a detail side elevation of an auxiliary counterbalancing device applied to my improved stair, the same being shown on an enlarged scale; Fig. 5 is a view on a like scale representing in side elevation said auxiliary counterbalancing device in a different position; Fig. 6 is a view representing a cross section through Fig. 4 on the line 6—6 thereof.

Referring now in detail to that embodiment of my invention illustrated in the drawings, 10 indicates a stair or ladder adapted for use with a fire escape 11 and forming the bottom movable member of the system of ladders or stairs constituting said fire escape. As is usual in such construction, the ladder or stair 10 is hinged on a horizontal rod 12 anchored in the vertical wall of the building on which the fire escape is located and projecting outwardly from the face of said wall. A bracket 14 secured to the wall below the rod 12 has upright arms 14^a, 14^b which provide vertical support for the outer end of said rod 12. The ladder 10 is of familiar construction and is shown in the drawing as comprising longitudinally extending laterally spaced bars 10^a, 10^b and transversely extending rods 10^b, which are

secured at longitudinally spaced intervals to the bars 10^a and constitute the steps of the ladder or stair. Angle-bars 10^c secured to the bars 10^a project upwardly therefrom at right angles and carry hand rails 10^d, 10^e located on each side of the ladder or stair. The bars 10^a are pivoted at their upper ends on the rod 12 which, as shown herein, also provides a bottom support for the lowest fixed section of the fire escape 11.

Means for counterbalancing the stair is provided as follows: 15 indicates a lever pivoted on the rod 12 adjacent the outer side of the stair 10, said lever being adapted to swing in a plane parallel to but laterally spaced from the vertical plane in which the median line of the stair swings. As shown herein, said lever is in the form of a channel bar having upper and lower flanges 15^a, 15^b. Said lever comprises a supporting arm 16 extending from the rod 12 a short distance alongside the stair, and a counterbalance arm 17 extending from the rod 12 in the opposite direction. The free end of the supporting arm 16 is provided with a rigid lateral projection 16^a which extends under the ladder or stair 10 and gives support to each of the longitudinal bars 10^a, 10^b of said stair. The lever 15 is made of such rigid construction that the weight of said bars 10^a, 10^b supported by the laterally extending member 16^a will not distort it. To the outer end of the counterbalance arm 17 is secured a counterweight 18. Equal support is thus provided at points a short distance beyond the fulcrum rod 12 for each longitudinal bar 10^a of the stair by the laterally extending projection 16^a of the counterbalance lever, so that there is no tendency of the outer end of either of said bars to sag one with respect to the other.

An auxiliary automatically shifting counterweight is provided as follows: 20 indicates a casting formed in the arc of a circle and having a base-plate or bar 21 made rigid with it and extending parallel to the lever 15. Said plate or bar is rotatively mounted on a block 22 rising from a bar 30 laterally spaced from the lever 15 and extending parallel thereto with its center of rotation in a line located in a vertical plane parallel to the lever 15 and extending at right angles to said lever through the fulcrum rod 12. The bar 30 is rigidly connected to the lever 15 by means of arms 30^a, 30^b. As shown

herein, the block 22 is tubular and the bar 21 is secured to it by a bolt 23 extending through said bar, through the block and through a horizontal flange 30^b of the bar 30. In the construction illustrated in the drawings, the bar 30 on which the casting 20 is rotatively mounted, is laterally spaced from the lever as described so that said casting may be swung end for end without striking the parts of the fixed stair 11. In said casting 20 is located a channel or chamber 20^a which extends in the arc of a circle. Said chamber has radial end walls 20^b, 20^c (see Figs. 5 and 6) which intersect the arcuate central axis of said chamber in points defining a line located in a vertical plane and parallel to the lever 15. It will thus be apparent that the length of said chamber will be divided into equal parts by the line located in a vertical plane and extending at right angles to the bar 30 (which is parallel to the lever 15) and through the fulcrum rod 12.

One end 24 of the casting 20 is prolonged to a point just above the horizontal flange 30^a of the bar 30 and is there provided with pivotally mounted, gravity operated catches 25 adapted to engage the opposite vertical edges of said flange 30^a and lock said casting in a position in a vertical plane parallel to the lever 15 with said end 24 upon one or the other side of the fulcrum rod 12. In the arcuate chamber 20^a of the casting are located a plurality of balls 26, in this case five, the number of balls depending upon the diameter and arcuate length of said chamber, and there being preferably a sufficient number of balls used so that the train of balls will extend from one end wall of the chamber to or nearly to the middle of the arcuate length of said chamber.

The operation of my improved counterbalanced stair is as follows: The stair normally stands in a horizontal position with the casting 20 so placed that all of the balls 26 are located in that end of the arcuate chamber 20^a which is on the same side of the fulcrum rod 12 as the counterbalance arm 17 of the lever. With the parts in this position, it is apparent that the moment of the counterweight 18 about the rod 12 plus the moment of the balls 26 carried by the auxiliary counterbalancing device about said rod, must be equal to the moment of the vertical support given the stair by the supporting arm 16, through the lateral member 16^a, about said rod, which is of necessity greater than the moment of the stair about the fulcrum rod 12 in order that said stair may be supported in horizontal position and prevented from rotating downwardly about said fulcrum. When one coming down the fire escape steps upon the stair 10 and by his weight causes the moment of said stair about the rod 12 to be in-

creased so as to be greater than the combined moments of the counterweight 18 and the balls 26 about said fulcrum rod, or when a fireman by means of a hook, reached up from below, imparts a downward pull on the free end of the stair, thereby increasing the moment of the stair about its fulcrum, the stair is caused to swing downwardly on its fulcrum rod 12.

It is apparent from a consideration of Figs. 1 and 4 that a slight swinging of the casting 20 to the left with the downward swing of the stair will swing the ball near the middle of the length of the chamber 20^a beyond a point vertically above the fulcrum rod 12 and said ball will then roll down toward the left-hand end of said chamber. A further swing downward of the ladder will cause the next ball to follow the first ball toward the left-hand end of said chamber, and this will continue until all of the balls have passed from the right-hand end of said chamber to the left-hand end of said chamber, when they will then add their moment to that of the ladder to counteract the effect of the counterweight 18. Thus the differential moment on the side of the ladder is gradually increased as the ladder descends.

In practice, the parts will be so designed, and the weight of the balls 26 so proportioned so that all the said balls will have reached the end of the tubular chamber 20^a on the stair side of the fulcrum rod 12 when the free end of the stair has reached a position about five or six feet from the ground at which time the stair and the balls together will exert a moment to swing the stair downwardly considerably in excess of the moment of the counterweight 18 on the side of the counterbalance arm tending to raise the stair, and this differential moment will positively hold the stair down when it reaches a position with its lower end against the ground so that the counterweight 18 will have no effect to raise it. When the ladder is returned to horizontal position, the balls will still remain in the left-hand end of the tubular chamber in the casting so as to exert their moment on the side of the stair, but by swinging said casting end for end on its pivotal connection with the bar 30, the end of the casting containing the balls is brought to the side of the fulcrum rod on which the counterweight 18 is located so that said balls again add their moment to the moment of said counterweight and hold the stair in raised position.

I claim as my invention:—

1. In combination with a vertically swinging device pivoted at one end to swing on a fulcrum, means for counterbalancing and supporting said vertically swinging device comprising a lever having a fulcrum coaxial with the fulcrum of said vertically swinging

device, said lever having a supporting arm adapted for the support of said vertically swinging device beyond its fulcrum, and counterbalancing means carried by said lever comprising a plurality of movable weights normally located on the side of said fulcrum opposite said supporting arm, and means supporting said movable weights constructed to direct the movement of said weights one by one toward a position on the opposite side of said fulcrum as the swinging device descends.

2. In combination with a vertically swinging device pivoted at one end to swing on a fulcrum, means for counterbalancing and supporting said vertically swinging device comprising a lever having a fulcrum coaxial with the fulcrum of said vertically swinging device, said lever having a counterbalancing arm and a supporting arm, the latter being adapted for the support of said vertically swinging device beyond its fulcrum, a counterweight on the counterbalance arm, and auxiliary counterbalancing means carried by said lever and located outside of the plane in which said vertically swinging device swings, said auxiliary counterbalancing means comprising a member containing an arcuate chamber having the median radial line of the arc in which said chamber is formed extending at right angles to said lever through the axis of its fulcrum, and a plurality of balls adapted to roll in said chamber, said balls forming a train extending from one end of said arcuate chamber to or near said median radial line.

3. In combination with a vertically swinging device pivoted at one end to swing on a fulcrum, means for counterbalancing and supporting said vertically swinging device comprising a lever having a fulcrum coaxial with the fulcrum of said vertically swinging device, said lever having a counterbalancing arm and a supporting arm, the latter being adapted for the support of said vertically swinging device beyond its fulcrum, a counterweight on the counterbalance arm, and auxiliary counterbalancing means carried by said lever, and located outside of the plane in which said vertically swinging device swings, said auxiliary counterbalancing means comprising a member containing an arcuate tubular chamber having the median radial line of the arc in which said chamber is formed extending at right angles to said lever through the axis of its fulcrum, and a plurality of shifting weights adapted to move in said chamber, said shifting weights forming a train extending from one end of said chamber to or near said median radial line, means for rotatively supporting said chambered member whereby it may be shifted end for end in a horizontal plane

parallel to said lever, and means for locking said member in position.

4. In combination with a vertically swinging stair having laterally separated, longitudinal bars fulcrumed to swing about the ends of said bars, means for counterbalancing and supporting said stair comprising a lever having its fulcrum coaxial with the fulcrum of said stair, said lever having a counterbalance arm and a supporting arm extending alongside of said stair to a point a short distance from its fulcrum, a counterweight on said counterbalance arm, said supporting arm being provided with a lateral extension adapted for the support of the laterally separated longitudinal bars of said stair, and auxiliary counterbalancing means carried by said lever and comprising a casting provided with an arcuate tubular chamber having the median radial line of the arc in which it is formed extending at right angles to said lever through its fulcrum, and a plurality of balls adapted to roll in said chamber, said balls forming a train extending from one end of said chamber to or near said median radial line.

5. In combination with a vertically swinging stair having laterally separated, longitudinal bars fulcrumed to swing about their ends, means for counterbalancing and supporting said stair comprising a lever having its fulcrum coaxial with the fulcrum of said stair, said lever having a counterbalance arm and a supporting arm extending alongside of said stair to a point a short distance from its fulcrum, a counterweight on said counterbalance arm, said supporting arm being provided with a lateral extension adapted for the support of the laterally separated longitudinal bars of said stair, and auxiliary counterbalancing means carried by said lever and comprising a casting provided with an arcuate tubular chamber having the median radial line of the arc in which it is formed extending at right angles to said lever through the axis of its fulcrum, a plurality of balls adapted to roll in said chamber, said balls forming a train extending from one end of said chamber to or near the said median radial line, said casting having a base rotatively supported above said lever to swing about said median radial line as an axis, and means for locking said casting in position.

In testimony that I claim the foregoing as my invention I affix my signature in the presence of two witnesses, this 28th day of April, A. D. 1911.

MILLARD GILMORE.

Witnesses:

CLARENCE E. MEHLHOPE,
GEORGE R. WILKINS.