

(19) **DANMARK**

(10) **DK/EP 2130771 T4**



Patent- og
Varemærkestyrelsen

(12) **Oversættelse af ændret
europæisk patentskrift**

-
- (51) Int.Cl.: **B 65 B 9/13 (2006.01)** **B 65 B 11/58 (2006.01)**
- (45) Oversættelsen bekendtgjort den: **2023-04-03**
- (80) Dato for Den Europæiske Patentmyndigheds bekendtgørelse om opretholdelse af patentet i ændret form: **2023-02-22**
- (86) Europæisk ansøgning nr.: **08010410.2**
- (86) Europæisk indleveringsdag: **2008-06-07**
- (87) Den europæiske ansøgnings publiceringsdag: **2009-12-09**
- (84) Designerede stater: **AT BE BG CH CY CZ DE DK EE ES FI FR GB GR HR HU IE IS IT LI LT LU LV MC MT NL NO PL PT RO SE SI SK TR**
- (73) Patenthaver: **MSK Emballage S.A.R.L., Rue des Genets, 01600 Reyrieux, Frankrig**
- (72) Opfinder: **Hannen, Chris, Nachtigallenweg 6, 47574 Goch, Tyskland**
- (74) Fuldmægtig i Danmark: **Zacco Denmark A/S, Arne Jacobsens Allé 15, 2300 København S, Danmark**
- (54) Benævnelse: **Indretning og fremgangsmåde til overtrækning af en varestabel med en slangefolie**
- (56) Fremdragne publikationer:
EP-A1- 2 036 818
DE-A1- 19 954 370
DE-U1- 9 001 321
US-A- 5 720 153
EP-A1- 1 174 343
EP-A1- 1 266 829
EP-A2- 1 029 786
DE-C3- 3 918 311

DESCRIPTION

The invention pertains to a device for drawing a tubular film over a stack of goods. The invention furthermore pertains to a method for drawing a tubular film over a stack of goods. A stack of goods particularly refers to a plurality of packages, packets, bags or similar units that are advantageously stacked into a cuboid stack of goods. According to the invention, the stack of goods may be accommodated on a pallet. This stack of goods is wrapped with a tubular film or with a film cover in order to provide the stack of goods with increased stability, as well as to protect the stack of goods from atmospheric influences. The stack of goods may, in principle, also consist of only a few stacked units or even a single larger unit such as, for example a domestic appliance (washing machine, refrigerator, dishwasher and the like). The stack of goods preferably has a cuboid shape. On the other hand, the stack of goods does not necessarily have to have this cuboid shape, but may basically also have other shapes.

Different variations of devices of the above-described type are known from practical applications. In these devices, the tubular film being supplied from a tubular film stock is opened above the stack of goods and gathered in the vertical direction. Subsequently, the gathered tubular film usually is transversely stretched in the horizontal direction. This transverse stretching is carried out such that the cross section or horizontal cross section of the transversely stretched tubular film is larger than the cross section or horizontal cross section of the stack of goods. Subsequently, the tubular film is drawn over the stack of goods and thereby ungathered again. These devices have basically proven successful in practical applications.

A device of the initially described type, which forms the basis of the invention, is known from DE 90 01 321 U1. This publication describes a device for drawing stretch film covers over a stack of goods, wherein the lower edge of the stretch film cover is folded over shortly before the end of the drawing process such that the stretch film cover is doubled in its lower edge region. This device only makes it possible to stabilize a stack of goods on a pallet in the lower region adjacent to the pallet.

In addition, DE 199 54 370 A1 discloses a device according to the preamble of claims 1 and 2 and a method for wrapping a stack of goods with a tubular film.

According to this publication, two tubular covers or two tubular film covers are successively drawn over a stack of goods in the same direction. In this case, the tubular film covers are supplied from two separate tubular film stocks.

5 EP 2 036 818 discloses a device according to Article 54(3), EPC.

The invention is based on the technical problem of disclosing a device of the initially described type, by means of which the load can be effectively secured in an enhanced fashion. The invention is furthermore based on the technical
10 problem of disclosing a corresponding method for drawing a tubular film over a stack of goods.

In order to solve this technical problem, the invention proposes a device according to claim 1 or according to claim 2.

15

According to the invention, the tubular film may consist of an elastomer. The lateral edges of the tubular film are advantageously folded inward in the delivery state (tubular film stock). This is referred to as a side-gusseted tubular film. The tubular film effectively may be tightly drawn over the stack of goods such that it
20 is positioned on the sidewalls of the stack of goods in a tight and form-fitting fashion, particularly due to elastic restoring forces. However, the tubular film also may be effectively drawn loosely over the stack of goods. According to one embodiment, the tubular film consists of a shrink film that is shrunk on the stack of goods. In one embodiment, the tubular film forms a film cover in the state, in
25 which it is drawn over the stack of goods. For this purpose, the tubular film separated from the tubular film stock is advantageously welded with a welding device such that it is closed on its upper side and on the upper side of the stack of goods. According to another embodiment, however, the top and the bottom of the tubular film drawn over the stack of goods may also be open.

30

According to the invention, the film strip may consist of a plastic or of a thermoplastic polymer. Furthermore, the film strip may according to the invention be at least sectionally positioned on the stack of goods with interposition of the tubular film. In this case, the film strip therefore is at least
35 sectionally positioned on the tubular film with its underside on the side of the stack of goods. The film strip is advantageously positioned on the tubular film with at least 30%, preferably with at least 40%, particularly with at least 50%, of

the surface area of its underside on the side of the stack of goods. According to a preferred embodiment of the invention, the film strip is positioned on the tubular film with at least 60%, preferably with at least 70%, particularly with at least 80%, of the surface area of its underside on the side of the stack of goods.

5 The film strip is advantageously positioned on the stack of goods or the tubular film arranged on the stack of goods in a form-fitting and/or frictional fashion. The film strip is preferably applied on the stack of goods or on the tubular film arranged on the stack of goods under the influence of elastic restoring forces and/or is shrunk on the stack of goods or on the tubular film arranged on the
10 stack of goods. According to an embodiment of the invention, the film strip has a shorter length than the tubular film and therefore effectively encloses the stack of goods in the form of a film strip. According to another embodiment of the invention according to claim 2 or according to claim 11, the film strip has the same length or essentially the same length as the tubular film and therefore
15 encloses the sidewalls of the stack of goods in their entirety or essentially in their entirety. The invention is based on the realization that the stack of goods or the tubular film drawn over the stack of goods effectively can be secured even better with the additional film strip.

20 According to a first alternative embodiment of the invention, the film strip is a tubular film section that can be drawn over the stack of goods wrapped with the tubular film. The tubular film section may in accordance with the invention be opened before it reaches the stack of goods and then drawn over the stack of goods. According to a preferred embodiment, the top and the bottom of the
25 tubular film section drawn over the stack of goods are open. The tubular film section may in accordance with the invention have a shorter length than the tubular film and therefore effectively enclose the stack of goods in the form of a film strip.

30 According to the first alternative embodiment of the invention, the tubular film section is supplied from the tubular film stock of the tubular film. The same film material is therefore used for the tubular film, as well as for the tubular film section. In this case, the tubular film section advantageously forms a side-gusseted tubular film in the delivery state. It is proposed that the tubular film and
35 the tubular film section consist of an elastomer.

A particularly advantageous embodiment of the invention is characterized in that the tubular film section is drawn over the stack of goods with the same drawing device used for drawing the tubular film over stack of goods. The tubular film and the tubular film section are advantageously drawn over the
5 stack of goods with the same displaceable or vertically displaceable stretching frame/lifting frame, wherein it is proposed that guide elements, which hold the tubular film and the tubular film section during the drawing process, are connected to the stretching frame/lifting frame. Such guide elements are preferably arranged on the four corners of the stretched tubular film of
10 rectangular cross section and the stretched tubular film section of rectangular cross section.

According to a preferred embodiment of the invention, a gathering device is provided for gathering the tubular film, as well as the tubular film section, before
15 it is drawn over the stack of goods. In this embodiment, the same gathering device is therefore used for gathering the tubular film, as well as for gathering the tubular film section. The gathering device advantageously features gathering elements or gathering brackets and gathering rollers, which are arranged on the four corners of the stretched tubular film of rectangular cross
20 section and the stretched tubular film section of rectangular cross section. According to an advantageous embodiment of the invention, the gathering device also serves as drawing device for drawing the tubular film and for drawing the tubular film section over the stack of goods.

25 According to the invention, the inventive device may feature a separating device, by means of which the tubular film, as well as the tubular film section, is separated from the tubular film stock. According to an embodiment, a welding device is additionally provided for welding the tubular film such that the tubular film can be drawn over the stack of goods in the form of a film cover.

30

According to the invention, transverse stretching of the tubular film may be carried out after the separation of the tubular film and after the gathering of the tubular film. According to the invention, a transverse stretching device may furthermore be provided for transversely stretching the tubular film, as well as
35 the tubular film section, before it is drawn over the stack of goods. In this case, the tubular film and the tubular film section are transversely stretched in such a way that the cross section or horizontal cross section of the transversely

stretched tubular film and of the transversely stretched tubular film section is larger than the cross section or horizontal cross section of the stack of goods. This transverse stretching advantageously takes place in the gathered state of the tubular film and in the gathered state of the tubular film section. A particularly advantageous embodiment of the invention is characterized in that the gathering device is also used as transverse stretching device. The gathering elements of the gathering device then also form the transverse stretching elements of the transverse stretching device. The transverse stretching elements or gathering elements advantageously move apart from one another transverse to the supply direction of the tubular film and the tubular film section.

An embodiment of the inventive device preferably operates as described below. The tubular film is initially supplied from the tubular film stock and opened above the stack of goods by means of an opening device. Subsequently, gathering elements of a gathering device move into the opened tubular film such that the inner side of the tubular film is positioned on these gathering elements. The tubular film is then respectively gathered on the gathering device or on the gathering elements. After the tubular film has been gathered, it is advantageously separated on its upper end by means of a separating device. If applicable, it may be welded by means of a welding device in order to form a film cover that is closed on its upper side. It is proposed that the gathered tubular film is transversely stretched such that its cross section is larger than the cross section of the stack of goods. In this case, the gathering device is preferably also used as transverse stretching device. The tubular film is drawn over the stack of goods after it has been gathered and transversely stretched. During this drawing process, the gathered tubular film is once again ungathered. According to an advantageous embodiment, the stack of goods is arranged on a pallet and the end of the tubular film is positioned on the underside of the lower pallet section or on the underside of the upper pallet section at the end of the drawing process. After the tubular film has been drawn over the stack of goods, a tubular film section is supplied from the tubular film stock and advantageously opened above the stack of goods by means of the opening device. Subsequently, the tubular film section is advantageously gathered on the gathering device. For this purpose, it is proposed that gathering elements move into the opened tubular film section such that the inner side of the tubular film section is positioned on these gathering elements. It is preferred that the gathered tubular film section is then transversely stretched such that its

cross section is larger than the cross section of the stack of goods. It is proposed that this transverse stretching is also carried out by means of the gathering device, which therefore is also used as transverse stretching device for the tubular film section. Subsequently, the tubular film section is drawn over
5 the stack of goods and the tubular film section is placed at the desired location on the stack of goods. If the tubular film section was previously gathered, un-gathering of the tubular film section takes place during this drawing process. If the stack of goods is arranged on a pallet, the one end of the tubular film section is in an advantageous embodiment of the invention positioned on the
10 underside of the pallet, particularly on the underside of the lower pallet section or on the underside of the upper pallet section. The tubular film section advantageously consists of an elastomer and the transversely stretched tubular film section positions itself on the sidewalls of the stack of goods during the drawing process under the influence of elastic restoring forces, namely with at
15 least sectional interposition of the tubular film previously drawn over the stack of goods.

A second alternative embodiment of the invention is characterized in that a banding device is provided, by means of which the film strip can be applied on
20 the stack of goods in the form of a film sleeve. In this context, the term film sleeve refers to the ends of at least one film strip section being connectable, particularly weldable, into a film strip enclosing the stack of goods or into a film sleeve enclosing the stack of goods by means of the banding device. It is preferred that the ends of at least two film strip sections can be connected,
25 particularly welded, into the film strip enclosing the stack of goods or into the film sleeve enclosing the stack of goods by means of the banding device. The banding device advantageously features at least one connecting device, particularly at least one welding device, by means of which the ends of at least
30 one film strip section can be connected or welded into the film sleeve enclosing the stack of goods.

According to an embodiment of the invention, the film sleeve or the at least one film section that can be connected into the film sleeve may be realized in the form of a stretch film. In this case, the film sleeve is positioned on the stack of
35 goods or on the tubular film wrapping the stack of goods in a form-fitting fashion, particularly under the influence of elastic forces. According to another embodiment of the invention, the film sleeve or the at least one film strip section

that can be connected into the film sleeve is realized in the form of a shrink film. A preferred embodiment is characterized in that a shrinking machine is arranged downstream of the banding device, wherein the film sleeve in the form of a shrink film sleeve can after its application on the stack of goods be shrunk
5 on the stack of goods or on the tubular film wrapping the stack of goods by means of said shrinking machine.

According to a variation of the invention, the film sleeve is initially produced by connecting, particularly welding, the ends of at least one film strip section and
10 the film sleeve is subsequently opened above the stack of goods such that the cross section or horizontal cross section of the opened film sleeve is larger than the cross section or horizontal cross section of the stack of goods, wherein the film sleeve is subsequently guided over the stack of goods from above such that the film sleeve respectively encloses the stack of goods or the sidewalls of the
15 stack of goods. According to the invention, the film sleeve may be opened above the stack of goods with a rectangular cross section or horizontal cross section. For this purpose, four guide elements advantageously move into the corners of the film sleeve. It is proposed that the film sleeve is transversely stretched above the stack of goods, namely such that the cross section or
20 horizontal cross section of the transversely stretched film sleeve is larger than the cross section or horizontal cross section of the stack of goods. In this case, the four aforementioned guide elements preferably also serve as transverse stretching elements. According to the invention, a film sleeve of an elastomer or of a stretch film may be used in this embodiment. After it has been guided over
25 the stack of goods, the film sleeve positions itself on the sidewalls of the stack of goods under the influence of elastic restoring forces in this case. For this purpose, the four guide elements are advantageously pulled out of the film sleeve from above.

30 In the following description, the term film strip particularly refers to a tubular film section and/or a film sleeve. According to an embodiment of the invention, the film strip is positioned in the upper third of the stack of goods, particularly in its upper quarter. In this context, the upper third or upper quarter refers to the height of the stack of goods and to the region or the side of the stack of goods,
35 from which the tubular film is supplied. This embodiment serves for additionally securing the stack of goods or the already applied tubular film in the upper region of the stack of goods.

According to another embodiment of the invention, the film strip may be positioned in the lower third of the stack of goods, particularly in its lower quarter. In this context, the lower third or lower quarter refers to the height of the stack of goods and to the region of the stack of goods, on which the end of the tubular film is arranged. If the stack of goods is arranged on a pallet, the lower third or lower quarter particularly refers to the corresponding vertical section of the stack of goods above the pallet. This embodiment serves for respectively securing the stack of goods or the tubular film already drawn over the stack of goods in its lower region.

According to a preferred embodiment of the invention, the stack of goods is arranged on a pallet and the film strip can be positioned in the lower region of the stack of goods and on the pallet. In this context, the lower region particularly refers to the above-defined lower third or lower quarter of the stack of goods. In this embodiment of the invention, the film strip is effectively used for connecting the stack of goods and the pallet and therefore for additionally securing the unit consisting of the stack of goods and the pallet in this region. A proposed embodiment of the invention is characterized in that the end of the film strip, particularly of the tubular film section, is positioned on an underside of the pallet.

According to an embodiment of the invention, the stack of goods or the unit consisting of the stack of goods and the pallet is vertically wrapped with the film strip. In this context, vertical wrapping means that the film strip extends over the height of two opposite sidewalls of the stack of goods, as well as over the upper side of the stack of goods and over the underside of the stack of goods or the underside of the pallet. Such vertical wrapping can be achieved by pivoting an inventive device by 90° or by pivoting components of the device relative to the wrapping by 90° relative to the stack of goods.

According to an embodiment of the invention, the length of the film strip amounts to less than 75%, preferably less than half, particularly less than 1/3, of the length of the tubular film. This length refers to the extent of the tubular film or of the film strip transverse or perpendicular to the circumferential direction of the tubular film or the film strip. A preferred embodiment of the invention is characterized in that the length of the film strip amounts to at least 1/6,

preferably at least 1/5 of the length of the tubular film, and to no more than half, preferably no more than 40%, of the length of the tubular film. The aforementioned embodiments, in which the length of the film strip is shorter than the length of the tubular film, serve for securing certain regions of the stack of goods or of the interpositioned tubular film.

5

According to a proposed embodiment of the invention according to claim 2 or according to claim 11, the length of the film strip corresponds to the length of the tubular film or essentially to the length of the tubular film. In this case, the film strip completely encloses the sidewalls of the stack of goods. The length of the film strip preferably amounts to at least 90%, particularly at least 95%, of the length of the tubular film in this embodiment. The film strip can also be positioned on the pallet of the stack of goods in these embodiments with long film strips. It is proposed that the end of the film strip is positioned on an underside of the pallet.

10

15

The above-defined technical problem is also solved with an inventive method according to claim 10 or according to claim 11.

According to a first alternative embodiment of the inventive method, the film strip is supplied in the form of a tubular film section. The tubular film section is advantageously opened, whereupon it is transversely stretched and subsequently drawn over the stack of goods. It is proposed that the tubular film section is initially gathered and once again ungathered when it is drawn over the stack of goods. The tubular film section is advantageously separated from the tubular film stock after it has been gathered. It is proposed that the tubular film section or the section of the tubular film intended therefor is initially opened and then gathered, whereupon it is transversely stretched, as well as subsequently drawn over the stack of goods and thereby ungathered. The separation of the tubular film section from the tubular film stock advantageously takes place after the tubular film section has been gathered.

20

25

30

According to a second alternative embodiment of the inventive method, the film strip is applied on the stack of goods enclosed by the tubular film in the form of a film sleeve, wherein the ends of at least one film strip section are connected into the film sleeve enclosing the stack of goods for this purpose. A film strip is advantageously supplied from a film strip stock, particularly a film strip roll, in

35

order to make available the film strip section. According to a proposed embodiment of the invention, two film strips are respectively supplied from a film strip stock, particularly a film strip roll. According to the invention, a film strip section may be made available by each film strip in order to produce a film sleeve and both film strip sections may be connected to one another, particularly welded to one another, in order to form the film sleeve. For this purpose, it is preferred that the two film strips are initially connected with their ends such that a film strip curtain is formed. The stack of goods being transported on a conveyor advantageously moves into and carries along this film strip curtain such that the stack of goods is covered with the film strip on three sides. Subsequently, the film strips or the film strip sections are advantageously guided around the fourth side of the stack of goods until they coincide, particularly until they coincide approximately in the center of the stack of goods. It is proposed that the two film strips or the two film strip sections are connected to one another, particularly welded to one another, at this location, as well as respectively separated from the remaining film strip. The separation may be realized, for example, with a resistance wire. Preferred methods and devices for producing such a film sleeve are described, in particular, in EP 1 029 786 A2 and in EP 1 174 343 A1.

According to a preferred embodiment of the invention the film strips or film strip sections are realized in the form of shrink film strips or in the form of shrink film strip sections. In this case, the film strips or the film strip sections respectively consist of shrinkable plastic. After the application of the shrink film sleeve, the stack of goods is preferably transferred into a shrinking machine, in which the shrink film sleeve is shrunk thereon.

The invention is based on the realization that the stack of goods and/or the tubular film positioned on the stack of goods can be additionally secured/fixed very effectively with the inventive device and with the inventive method. Very effective additional securing or fixing can also be achieved, in particular, in the region between the pallet and the lower section of the stack of goods. The combination of a tubular film on the one hand and a film strip on the other hand causes surprisingly advantageous additional securing of the load. The invention is furthermore based on the realization that the inventive measures can be implemented in a relatively simple fashion. This applies, in particular, if the film strip in the form of a tubular film section can be applied with the same device or

with the same relevant device components used for applying the tubular film on the stack of goods. No elaborate and costly modifying or retrofitting measures are required for this purpose. However, the application of the film strip in the form of a film sleeve is likewise characterized by little effort and simplicity. In addition, the inventive method can be carried out with high precision and functional reliability. The additional securing of the stack of goods or the load and/or of the tubular film already applied on the stack of goods can be realized with relatively low costs.

10 The invention is described in greater detail below with reference to the drawings that merely show an exemplary embodiment. In these schematic drawings:

Figure 1 shows a side view of a preferred embodiment of an inventive device,

15 Figure 2 shows a sectioned top view of the object according to Figure 1, and

Figure 3 shows a side view of a stack of goods wrapped in accordance with the invention.

20 A preferred embodiment of a device for drawing a tubular film 1 over a stack of goods 2 is illustrated in the figures. In the exemplary embodiment, the stack of goods 2 consists of a plurality of packets that are stacked into a cuboid on a pallet 3. The tubular film 1 initially is supplied in conventional fashion from a tubular film stock 4 and opened above the stack of goods 2 by means of an opening device 5. Subsequently, four gathering elements 6 of a gathering device 15 are moved into the opened tubular film 1 such that the inner side of the tubular film 1 is positioned on the gathering elements 6. In the exemplary embodiment, the gathering elements 6 are advantageously arranged on the four corners of an opened or spread-out tubular film 1 with rectangular cross section.

25 In the exemplary embodiment, the gathering elements 6 respectively feature a bent gathering bracket 7 that extends transverse to the supply direction Z of the tubular film 1. The gathering device 15 furthermore features roller arrangements 9 that are not described in greater detail here.

35 The opened tubular film 1 is initially gathered on the gathering device 15. This gathered state of the tubular film 1 is illustrated in Figure 1 underneath the roller arrangements 9. After it has been gathered, the tubular film 1 is transversely

stretched such that its horizontal cross section is larger than the horizontal cross section of the stack of goods 2. According to a particularly preferred embodiment and in the exemplary embodiment, the gathering elements 6 or gathering brackets 7 are used as transverse stretching elements and the gathering elements 6 are diagonally moved apart from one another in order to transversely stretch the tubular film 1. The transversely stretched state of the tubular film 1 is illustrated particularly well in Figure 2. After it has been gathered and transversely stretched, the tubular film is drawn over the stack of goods 2. In the exemplary embodiment, the gathering elements 6 preferably also form the guide elements for the drawing process. For this purpose, the gathering elements 6 can be respectively displaced vertically or vertically downward. The gathering elements 6 are advantageously connected to a vertically displaceable stretching frame or lifting frame. Although this is not illustrated in greater detail, the gathered tubular film is once again ungathered during the drawing process or during the vertical motion of the gathering elements 6, wherein the folds in the gathered tubular film 1 are gradually pulled apart and removed. According to a preferred embodiment and in the exemplary embodiment, the gathering elements 6 are vertically displaced as far as into the region underneath the pallet 3. At this location, the gathering elements 6 are moved inward in the direction of the pallet 3 and the end of the tubular film is ultimately removed from the gathering brackets 7 and positioned on the underside of the lower pallet section 14.

After the application of the tubular film 1, the inventive tubular film section 8 is drawn over the stack of goods 2. This is realized with the same device - illustrated in Figures 1 and 2 - used for drawing the tubular film 1 over the stack of goods. The tubular film section 8 is initially supplied from the tubular film stock 4 and opened by means of the opening device 5. In this case, four gathering elements 6 subsequently also move into the opened tubular film section 8 in this case such that the inner side of the tubular film section 8 is positioned on these gathering elements 6. In the exemplary embodiment, the gathering elements 6 are advantageously arranged on the four corners of the opened or spread-apart tubular film section 8 with rectangular cross section. The tubular film section 8 is initially gathered and separated from the tubular film stock 4 after the gathering process. Subsequently, the tubular film section 8 is drawn over the stack of goods 2. In this case, the drawing process is also carried out by means of the gathering device 15 or with the aid of the gathering

elements 6. The gathered tubular film section 8 is likewise ungathered again during this drawing process, wherein the folds in the gathered tubular film section 8 are gradually pulled apart and removed. In the exemplary embodiment according to Figure 3, the tubular film section 8 is positioned in the lower quarter of the stack of goods 2 and connects the stack of goods 2 to the pallet 3. In this exemplary embodiment, the length l of the tubular film section 8 amounts to slightly less than $1/3$ of the length L of the tubular film 1. In order to position the tubular film section 8 at this location, the gathering elements 6 or the lifting frame with the gathering elements 6 initially has to be displaced into this lower region, whereupon the tubular film section 8 is ungathered and positioned on the stack of goods 2. The tubular film section 8 preferably consists of an elastomer film that is positioned on the stack of goods 2 in a tight and form-fitting fashion under the influence of elastic restoring forces. In the exemplary embodiment, the gathering elements preferably are likewise vertically displaced as far as into the region underneath the pallet 3 while the tubular film section 8 is drawn over the stack of goods. In this case, the coupling elements 6 are then moved inward in the direction of the pallet 3 and the end of the tubular film section 8 is removed from the gathering brackets 7 and positioned on the underside of the lower pallet section 14.

In other respects, an embodiment, in which the tubular film section 8 is arranged in the upper third of the stack of goods 2, is illustrated in Figure 3 with dot-dash lines. According to the invention, more than one tubular film section 8, for example two tubular film sections 8, may be drawn over the stack of goods 2. According to claim 1 or according to claim 10, the length l of the tubular film section 8 amounts to less than half of the length L of the tubular film. Another preferred embodiment of the invention is characterized in that the length l of the tubular film section 8 corresponds to the length L of the tubular film or essentially corresponds to the length L of the tubular film. However, this embodiment is not illustrated in the figures.

In the exemplary embodiment illustrated in the figures, the gathering device 15 for the tubular film 1 and for the tubular film section 8 is preferably also used as transverse stretching device and as drawing device. This embodiment is characterized in that it is particularly simple and at the same time functionally reliable. The tubular film 1, as well as the tubular film section 8, advantageously consists of a stretch film or of an elastomer film that positions itself on the stack

of goods 2 under the influence of elastic restoring forces. After the application on the stack of goods, the tubular film 1, as well as the tubular film section 8, extends over the circumference of the stack of goods.

Patentkrav

5 1. Indretning til overtrækning af en varestabel (2) med en slangefolie (1), hvor der er tilvejebragt en slangefolieforsyning (4), hvorfra slangefolien (1) kan tilføres og kan trækkes over varestablen (2) med en overtrækningsindretning under den forudsætning, at slangefolien (1) i overtrukket tilstand dækker eller i det væsentlige dækker varestablens (2) sidevægge, og hvor mindst et foliebånd endvidere kan påføres perifrisk på varestablens (2) omfang på varestablen (2), der er dækket med slangefolie (1), hvor foliebåndet er et slangefolieafsnit (8), der kan trækkes over varestablen (2), der er dækket med slangefolie (1), og hvor slangefolieafsnittet (8) efter overtrækning af varestablen (2) med slangefolien (1) kan tilføres fra slangefolieforsyningen (4), hvorfra også slangefolien (1) kan tilføres, således at det samme foliemateriale anvendes både til slangefolien (1) og til slangefolieafsnittet (8), **kendetegnet ved, at** slangefolieafsnittet (8), der er trukket over varestablen (2), er udformet åbent foroven og forneden, og hvor foliebåndets længde l er mindre end halvdelen, fortrinsvis mindre end $1/3$ af slangefoliens (1) længde L .

20 2. Indretning til overtrækning af en varestabel (2) med en slangefolie (1), hvor der er tilvejebragt en slangefolieforsyning (4), hvorfra slangefolien (1) kan tilføres og kan trækkes over varestablen (2) med en overtrækningsindretning under den forudsætning, at slangefolien (1) i overtrukket tilstand dækker eller i det væsentlige dækker varestablens (2) sidevægge, og hvor mindst et foliebånd endvidere kan påføres perifrisk på varestablens (2) omfang på varestablen (2), der er dækket med slangefolie (1), **kendetegnet ved, at** foliebåndet anlægges på varestablen (2) i det mindste områdevist ved indføjelse af slangefolien (1), at der er tilvejebragt en banderoleringsindretning, hvormed foliebåndet efter overtrækning af slangefolien (1) kan anbringes som foliebanderole på varestablen (2), hvor enderne af mindst et foliebaneafsnit kan forbindes med foliebanderolen, der omgiver varestablen, med banderoleringsindretningen.

30 3. Indretning ifølge krav 1, hvor slangefolieafsnittet (8) kan overtrækkes ved hjælp af overtrækningsindretningen, ved hjælp af hvilken også slangefolien (1)

overtrækkes.

5 **4.** Indretning ifølge et af kravene 1 eller 3, hvor der er tilvejebragt en tværstrækningsindretning, ved hjælp af hvilken både slangefolien (1) og slangefolieafsnittet (8) strækkes på tværs, før de trækkes over varestablen (2).

10 **5.** Indretning ifølge krav 2, hvor banderoleringsindretningen omfatter mindst en forbindelsesindretning, især mindst en svejseindretning, med hvilken enderne af mindst et foliebaneafsnit kan forbindes eller svejses sammen med foliebänderolen, der omgiver varestablen (2).

15 **6.** Indretning ifølge et af kravene 2 eller 5, hvor en krympemaskine er efterkoblet banderoleringsindretningen og med hvilken foliebänderolen, der er udformet som krympefoliebänderole, kan påkrympes på varestablen (2).

20 **7.** Indretning ifølge et af kravene 1 til 6, hvor varestablen (2) er anbragt på en palle (3), og hvor foliebåndet kan anbringes i varestablens (2) nedre område og på pallen (3), hvor en ende af foliebåndet fortrinsvis kan lægges an på en underside af pallen (3).

8. Indretning ifølge et af kravene 2 til 7, hvor foliebåndets længde l er mindre end halvdelen, fortrinsvis mindre end $1/3$ af slangefoliens (1) længde L .

25 **9.** Indretning ifølge et af kravene 2 til 7 for så vidt de viser tilbage til krav 2, hvor foliebåndets længde l svarer til slangefoliens (1) længde L eller i det væsentlige slangefoliens (1) længde L .

30 **10.** Fremgangsmåde til overtrækning af en varestabel (2) med en slangefolie (1), hvor slangefolien (1) trækkes over varestablen (2) under den forudsætning, at slangefolien (1) i overtrukket tilstand dækker eller i det væsentlige dækker varestablens (2) sidevægge, og hvor mindst et foliebånd endvidere påføres perifrisk på varestablens (2) omfang på varestablen (2), der er indhyllet i slangefolien (1), hvor foliebåndet tilføres som slangefolieafsnit (8), der

trækkes over varestablen (2), som er dækket med slangefolien (1), hvor slangefolieafsnittet (8) efter overtrækning af varestablen (2) med slangefolien (1) tilføres fra slangefolieforsyningen (4), hvorfra også slangefolien (1) tilføres, således at det samme foliemateriale anvendes både til slangefolien (1) og til slangefolieafsnittet (8), **kendetegnet ved, at** slangefolieafsnittet (8), der er trukket over varestablen (2), er udformet åbent foroven og forneden, og at slangefolieafsnittets (8) længde l er mindre end halvdelen af slangefoliens længde L .

5

11. Fremgangsmåde til overtrækning af en varestablet (2) med en slangefolie (1), hvor slangefolien (1) trækkes over varestablet (2) under den forudsætning, at slangefolien (1) i overtrukket tilstand dækker eller i det væsentlige dækker varestablets (2) sidevægge, og hvor mindst et foliebånd endvidere kan påføres perifrisk på varestablets (2) omfang på varestablet (2), der er indhyllet i slangefolien (1), **kendetegnet ved, at** foliebåndet anlægges på varestablet (2) i det mindste områdevist ved indføjelse af slangefolien (1), at foliebåndet efter overtrækning af slangefolien (1) kan anbringes som foliebanderole på varestablet (2), der er indhyllet i slangefolien (1), og hvor enderne af mindst et foliebaneafsnit forbindes med foliebanderolen, som omgiver varestablet (2).

10

15

20

12. Fremgangsmåde ifølge krav 10, hvor det tilførte slangefolieafsnit (8) åbnes, derefter strækkes på tværs og til slut trækkes over varestablet (2).

13. Fremgangsmåde ifølge krav 12, hvor slangefolieafsnittet (8) først samles og ved overtrækning over varestablet (2) strækkes igen.

25

Fig.1

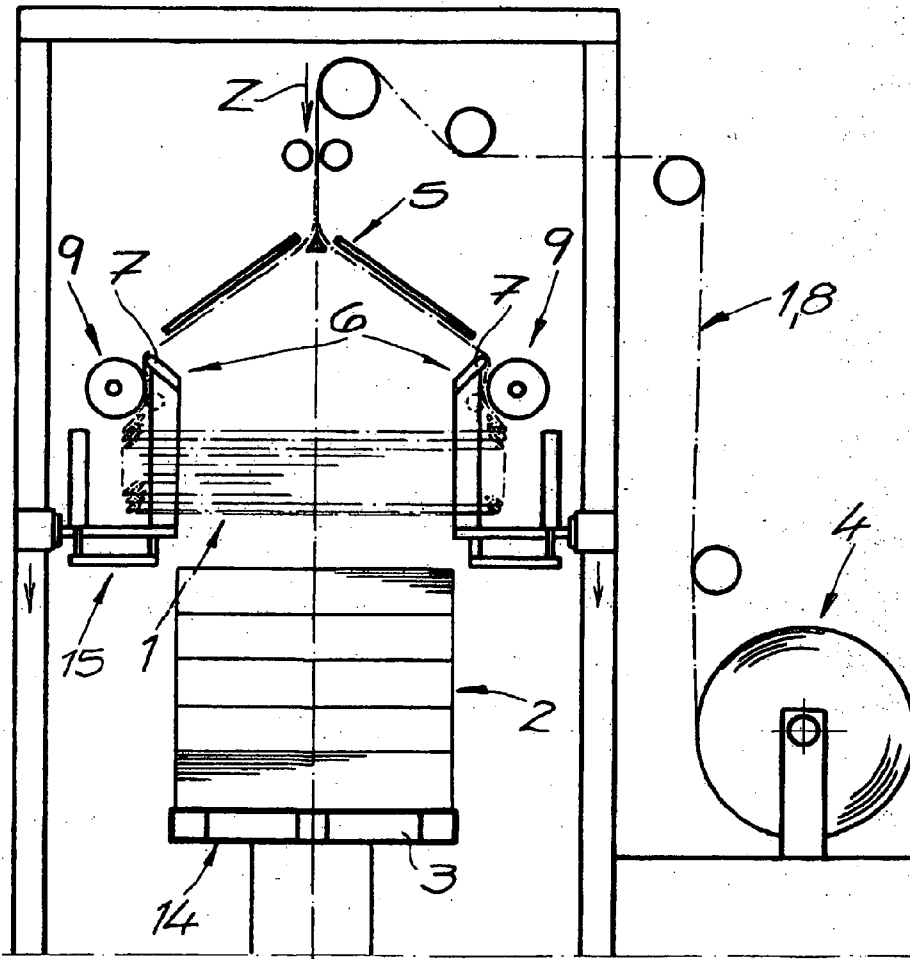

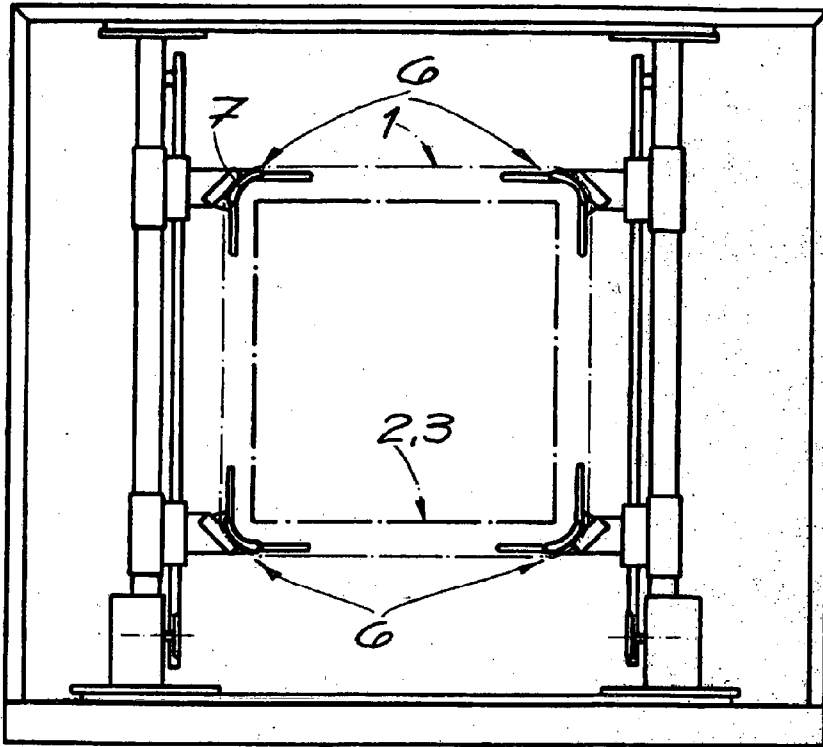

Fig. 2

Fig. 3

