

SPENCER & LAMB.

Sewing Machine.

No. 22,137.

Patented Nov. 23, 1858.

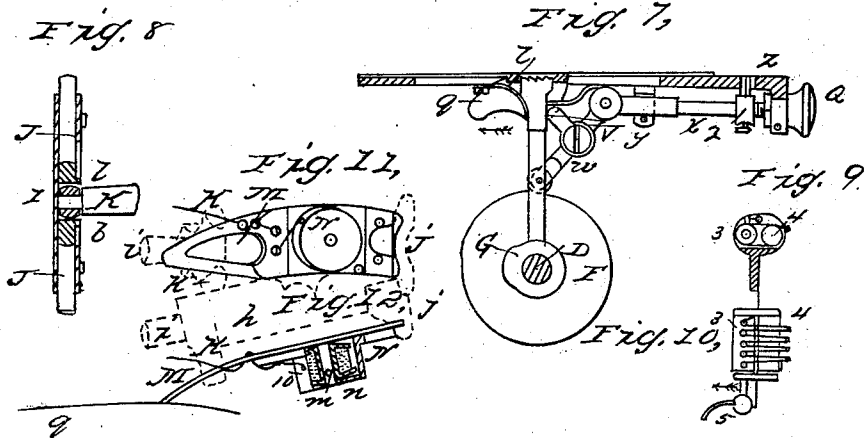
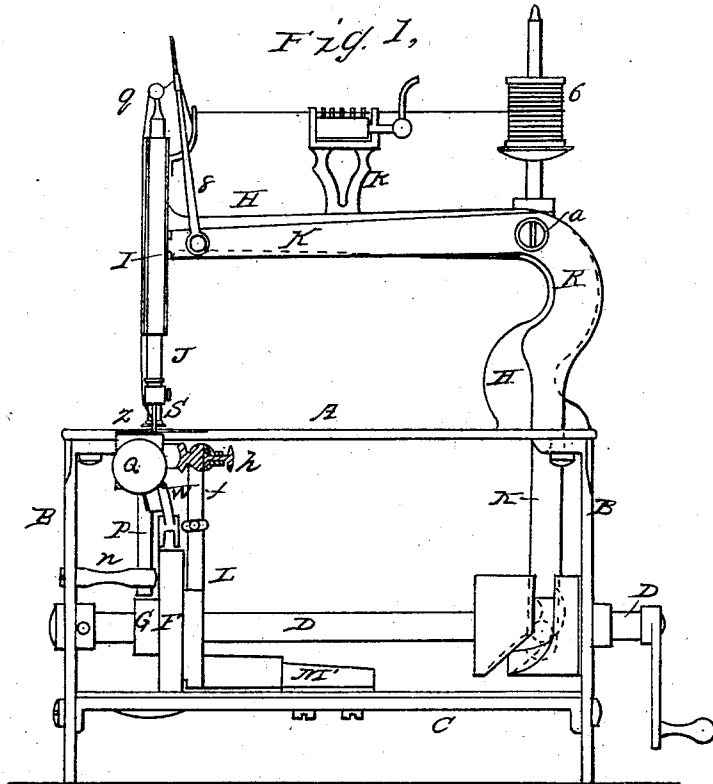

SPENCER & LAMB.

Sewing Machine.

No. 22,137.

Patented Nov. 23, 1858.

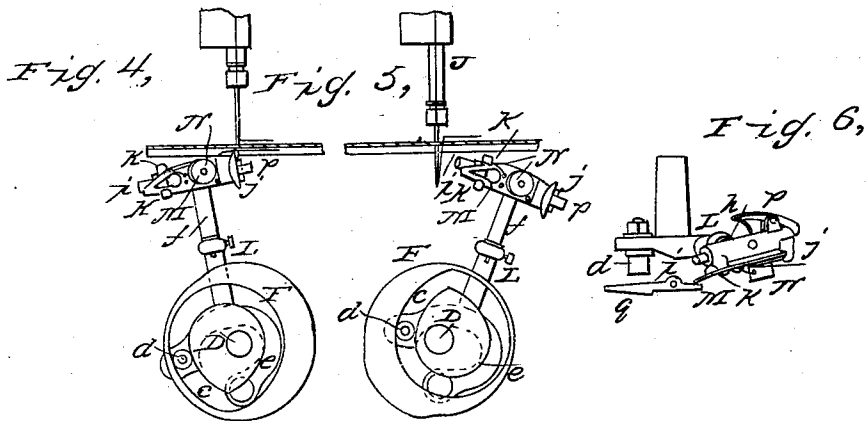
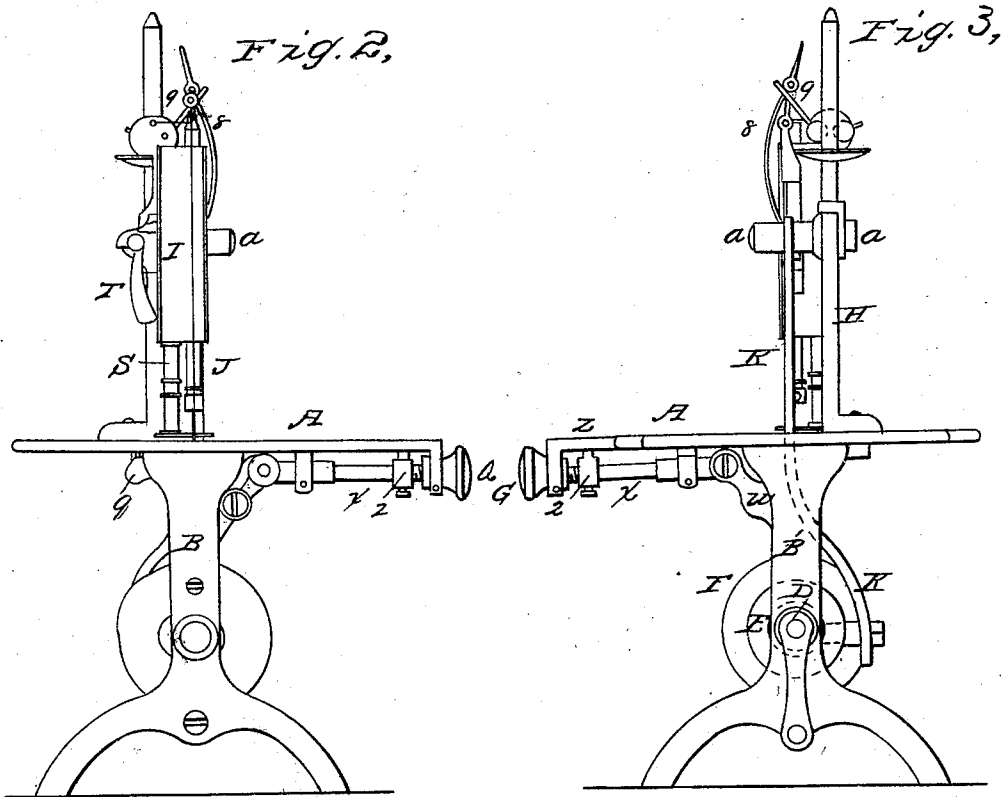

UNITED STATES PATENT OFFICE.

JAMES H. SPENCER AND THOMAS LAMB, OF PHILADELPHIA, PA.

IMPROVEMENT IN SEWING-MACHINES.

Specification forming part of Letters Patent No. 22,137, dated November 23, 1858.

To all whom it may concern:

Be it known that we, JAMES H. SPENCER and THOMAS LAMB, both of the city of Philadelphia and State of Pennsylvania, have invented certain new and useful Improvements in Sewing-Machines; and we do hereby declare the following to be a full, clear, and exact description of the same, reference being had to the accompanying drawings and to the letters of reference marked thereon.

Our invention relates to improvements in sewing-machines for producing the lock-stitch; and our improvements consist in a novel combination of a reciprocating or vibrating shuttle-holder with permanent and yielding projections, and a spring-catch for retaining the shuttle-plate and its spool, the whole being arranged in respect to each other and to a lip projecting from the cloth-plate, substantially in the manner fully set forth hereinafter.

Our invention further consists in a peculiar arrangement of cams, rods, and arms for feeding the fabric and regulating the feed, and in a combination and arrangement of cylinders and pins for imparting the necessary tension to the fabric and for regulating the amount of tension.

In order to enable others skilled in the art to make and use our improvements, we will now proceed to describe their construction and operation.

On reference to the accompanying drawings, which form a part of this specification, Figure 1 is a side view, showing our improvements in sewing-machines; Fig. 2, a front view; Fig. 3, a back view; Figs. 4 and 5, detached views, showing the shuttle-carrier and arm in different positions; Fig. 6, a plan view of Fig. 5; Fig. 7, a view of the feeding device; Fig. 8, a sectional view of the needle-bar and its guide; Figs. 9 and 10, views of the device for regulating the tension of the needle-thread; Figs. 11 and 12, enlarged views, illustrating the peculiar construction of the shuttle.

Similar letters refer to similar parts throughout the several views.

A represents the cloth-plate of the machine, resting on and secured to the front leg, B, and rear leg, B', which are connected together near the bottom by the longitudinal bar C.

D is the main driving-shaft, arranged to turn in the opposite legs, B and B', and to this shaft are secured the scroll-grooved cylinder E and

the cams F and G, all of which are alluded to hereinafter.

To the rear end of the cloth-plate A is secured the stationary arm H, to the end of which is attached the guide I for the needle-bar J, which is furnished with the ordinary sewing-machine needle. To a pin, *a*, on the arm H is hung the needle-lever K, one arm of which projects through the cloth-plate A, and is furnished at the end with a pin having a roller adapted to the scroll-groove in the cylinder E, the other arm of the needle-lever being connected to the needle-bar J in the manner illustrated in the sectional view, Fig. 8, on reference to which it will be observed that the end of the arm fits between two blocks, *b* and *b'*, contained in an oblong slot in the needle-bar. These blocks are hung to the needle-bar by means of pins on which the blocks can turn freely and accommodate themselves to the different angles assumed by the arm during the movement of the machine.

In the inner face of the cam F is cut an irregular eccentric recess, *e*, the form of which will be best observed on reference to Figs. 4 and 5. Into this recess fits a roller, *d*, on a pin secured to the end of the curved arm *e* of the shuttle-lever L, the latter being arranged to turn on a stationary pin which forms a part of the plate M, the latter being secured to the longitudinal bar C.

In the lever L a socket is formed for the reception of the stem *f*, to the top of which is secured the shuttle-holder, which consists of a hollow cylinder, *h*, in which slides a pin, *i*. At one end of the cylinder *h* is a projection, *j*, on the pin *i*, and on the opposite end of the cylinder two projections, *k k*.

M is the shuttle-plate, the peculiar construction of which is best illustrated in Figs. 11 and 12. In the face of this plate is a recess with dovetailed edges, and into this recess fits a casing, N, to the inside of which is secured a pin *m*, for receiving a spool, *n*, the latter being at liberty to turn freely on the pin. The shuttle is retained in its proper position at one end and at some distance from its point by the projections *k k* on the cylinder *h*, and at the opposite end by the projection *j* on the end of the pin *i*. A spring contained within the cylinder *h* acts on the pin *i* in such a manner as to cause the projection *j* to bear against the rear end of the shuttle and keep it in contact

with the retaining-projections of the holder. The spring is sufficiently elastic, however, to allow the pin *i* to yield to a limited extent, affording just sufficient room for the loop of the needle-thread to pass freely between the projections *k k* and the shuttle-plate at one end and the projection *j* and the shuttle-plate at the opposite end, and in order to facilitate this passage of the needle-thread both the projections and plate are smoothly rounded off at the points with which the thread must come in contact.

To the back of the cylinder *h* is jointed a spring-catch, *p*, the hooked end of which bears against the end of the pin *i*, or against its projection *j*, and thus prevents the shuttle, in passing through the loop, from being forced too far back. When the shuttle has to be removed from its holder, the spring-arm of the catch *p* may be depressed and the pin *i* drawn back, when the shuttle readily escapes, and when the spool requires replenishing with thread the casing may be slid from its recess and the spool removed for that purpose.

Now, it will be observed on reference to Fig. 6, that the shuttle and its holder are set at an angle to the path in which it moves, and also at an angle to a lip, *q*, which is parallel to that path, and which projects from the under side of the cloth-plate *A*. The object of this arrangement will be apparent hereinafter. This lip *q* has a recess for the passage of the needle, and is so situated as regards the shuttle-plate that the point of the latter moves in close contiguity to but not in actual contact with the inner face of the lip.

In the cloth-plate is the usual needle-hole, and in juxtaposition with the latter oblong holes, through which pass projections on the rod *P*, Fig. 8, the projections fitting in the holes laterally, but having more or less longitudinal play. The tops of the projections are furnished with pointed teeth, which are abrupt and straight on one side, but inclined on the opposite side. The rod *P* is guided by a bracket, *u*, projecting from the inside of the front standard, *B*, in such a manner, however, that it may be allowed a slight vibratory movement transversely with the machine. The bottom of the rod *P* rests on the edge of the cam *G*, and near the top of the rod is an enlargement, against which bears the end of an arm, *v*, which is hung loosely to a pin secured to another arm, *w*, midway, or thereabout, between its two ends. One of the ends of the arm *w* is furnished with a roller, the edge of which coincides with and bears on the edge of the cam *F*. The opposite end of the arm *w* is jointed to the end of the rod *x*, which slides between the jaws of a forked bracket, *y*, which confines the rod laterally, but allows it to have a slight vertical movement. A thumb-nut, *Q*, is arranged to turn freely, but to have no longitudinal movement, in a bracket, *z*. Attached to the cloth-plate and into this nut screws the end of the rod *x*, so that by turning the nut this rod may be moved in one direc-

tion or the other. An adjustable collar, 2, is attached to the rod *x*, and a pin on this collar projects into a hole in the projection *z* of the cloth-plate, so as to indicate the length of the stitch, as explained hereinafter.

On the stationary arm *H*, Fig. 1, is a frame, *R*, in which are two small cylinders, 3 and 4, Fig. 10, one being stationary and the other capable of being turned by means of the handle 5, and each of the cylinders is furnished with a series of pins.

S, Fig. 2, is the pressure-pad, operating in the same guide as that which contains the needle-bar. This pad is of the same form as those usually employed in sewing-machines, and is pressed down by means of a spring in the usual manner, the operator being enabled to raise the pad by means of a small arm, *T*, which is so formed and so adapted to a projection from the pressure-pad that the latter can retain its elevated position until released by the operator. The needle-thread passes from a spool, 6, (which turns freely on a pin attached to the stationary arm *H*,) to the cylinders 3 and 4. There is lapped round the first pin of one cylinder, then round the first pin of the other cylinder, and so on throughout, the thread being lapped over every pin, if necessary. From the cylinders the thread passes through an eye in the bracket 7, attached to the guide *I*, thence through an eye in the rod attached to the end of the needle-lever, thence through an eye, *g*, in the top of the needle-bar *J*, and thence through the eye of the needle to the fabric. The shuttle-thread passes from the spool in the casing *N* through a hole, 10 in the latter, thence through a hole in the shuttle, returning through another hole, thence through a third hole, returning through a fourth hole to the front of the shuttle, and thence to the fabric.

Operation: The driving-shaft *D* being caused to revolve by means of any of the usual appliances, a vibrating motion will be imparted to the needle-lever *K* through the scroll-grooved cylinder *E*, and consequently, a reciprocating motion to the needle. At the same time a vibrating motion will be imparted to the shuttle-arm *L* through the scroll-recess in the inner face of the cam *F*, a vertical reciprocating motion to the rod *P* through the cam *G*, as well as a short vibrating motion to the same rod, caused by the operation of the cam-wheel *F* on the arm *w*, and through the latter on the arm *v*. The stitch is formed, as in other lock-stitch machines, by passing the shuttle through the loop of the needle-thread. A detailed description of the operation of the above-described devices in accomplishing the result will therefore be unnecessary here. It will suffice to observe that, as the shuttle vibrates from the position shown in Fig. 5 to that illustrated in Fig. 4, the point of the shuttle catches the loop, which cannot slip from the point on account of the lip *q*. As the shuttle moves forward it yields to a limited extent, so that the loop may pass freely

between the shuttle and projections *k k*, and by the time the shuttle reaches the position shown in Fig. 4 the loop has escaped from between the shuttle and projections and the shuttle has recovered its original position. Thus the shuttle-thread becomes interlocked with the needle-thread forming the stitch, which is drawn tight up into the fabric by the rising of the needle. Now, in the shuttles of other sewing-machines, the spool of thread has hitherto been placed longitudinally with the shuttle, the thread passing through one or more holes in the side of the shuttle-case. It will be evident that a different degree of tension is imparted to the thread by this arrangement, according to the portion of the spool from which the thread is being unwound; for, if it is being taken from the rear of the spool, it will form a different angle from that which it assumes when drawn from the front end, and this difference of angle must produce a difference in the friction of the thread as it passes through the hole, and a difference in the tension must be the result. By the use of a spool hung to a pin placed at right angles, or thereabout, to the face of the shuttle, as in our improvements, it will be evident that this defect will be entirely obviated. By adopting this plan, however, it becomes necessary to place the shuttle at an angle, as illustrated in Figs. 6 and 11, in order that it may pass freely through the loop without the latter coming in contact with the spool-case.

With regard to our mode of regulating the tension of the needle-thread, it will be observed, on reference to Figs. 9 and 10, that on turning the handle 5 in the direction of the arrow the succession of loops of thread must be stretched and caused to bear more or less on the surface of the cylinder 3, according to the extent to which that cylinder has been turned, and consequently, that the friction on the thread may be increased or diminished at pleasure. Although one of the tension-cylinders has been described as stationary, both may be made movable without any alteration in the result.

The feeding apparatus illustrated in Fig. 7 operates as follows: The rod P is, in the first instance, elevated by the action of the cam G, so that the teeth at the top of the rod shall catch against the under side of the fabric. A swell on the edge of the cam F then raises the arm *w* and causes the arm *v* to push against the rod P and force it with a sudden movement in the direction of the arrow, thus giving the required amount of feed. A spring, *l*, serves to restore the rod P and arm *v* to their former positions as the cams continue to revolve. Should the rod *x*, to which the arm

w is hung, be drawn back, by turning the thumb-nut Q in a direction contrary to that pointed out by the arrow the forward movement of the rod P would be diminished and the stitch consequently reduced in length. In order to adjust the stitch to any required length the operator, as he turns the nut Q, has merely to observe the pin on the collar 2, and note its position in the oblong slot in the projection *z* of the cloth-plate, into which slot the said pin projects.

Having now described the nature of our improvements and the manner in which the same may be carried into effect, we wish it to be understood that, although we have described the shuttle as moving in the arc of a circle, we do not desire to confine ourselves to that particular movement, as a horizontal motion would be equally as effective. We wish it also to be understood that we do not claim, broadly, causing the carrier to convey the shuttle over the required space independently of any shuttle-race; but

We claim and desire to secure by Letters Patent—

1. The vibrating or reciprocating carrier *h*, with its permanent projections *k k*, yielding projection *j*, and spring-retaining catch *p*, in combination with the shuttle-plate M, its casing N, and spool *n*, when the several parts are constructed substantially as described, and when they are arranged in respect to each other and to the lip *q*, as and for the purpose herein set forth.

2. We do not claim, broadly, feeding the fabric by the combined vertical and lateral motion of a roughened-surface feed-bar on the said fabric, as such a device is described in the patent of A. B. Wilson, granted December 19, 1854; but we claim the arrangement of parts herein described for feeding the fabric and regulating the amount of the feed—that is to say, the cams F and G, spring-rod P, arms *w* and *v*, the rod *z*, its collar 2, and adjustable nut Q.

3. The cylinders 3 and 4, with their respective pins, when arranged in respect to each other to receive the folds of the needle-thread, as herein set forth, so that by turning one or both of the said cylinders the pins may cause more or less of the folds to bear against the surface of the cylinders, as herein set forth.

In testimony whereof we have signed our names to this specification before two subscribing witnesses.

JAS. H. SPENCER.
THOMAS LAMB.

Witnesses:

HENRY HOWSON,
HENRY ODIORNE.