



US 20050002810A1

(19) **United States**

(12) **Patent Application Publication**
Gould et al.

(10) **Pub. No.: US 2005/0002810 A1**

(43) **Pub. Date: Jan. 6, 2005**

(54) **PORTABLE VACUUM SYSTEM**

(52) **U.S. Cl. 417/472**

(76) Inventors: **William Gould**, Wantage, NJ (US);
Peter S. Gambino, Lyncroft, NJ (US)

(57) **ABSTRACT**

Correspondence Address:
COLLIER SHANNON SCOTT, PLLC
3050 K STREET, NW
SUITE 400
WASHINGTON, DC 20007 (US)

A portable and disposable vacuum system that may be used for collecting, containing and disposing of material is disclosed. The vacuum system may include a relatively rigid plastic bellows container with an upper opening. A spring may be inserted into the bellows container through the opening. A cap may be sealed to the bellows container at the upper opening. The spring may extend from the cap to the base of the container so as to bias the container into an expanded position. The cap may include one or more couplers that provide for the ingress and egress of fluid to and from the container. A suction tube may be connected to one of the couplers and an exhaust fluid receptacle may be connected to the other coupler. A valve may control the flow of fluid through the suction tube. In an alternative embodiment a powered vacuum device may be connected to the other coupler.

(21) Appl. No.: **10/718,537**

(22) Filed: **Nov. 24, 2003**

Related U.S. Application Data

(60) Provisional application No. 60/429,079, filed on Nov. 26, 2002.

Publication Classification

(51) **Int. Cl.⁷ F04B 43/00**

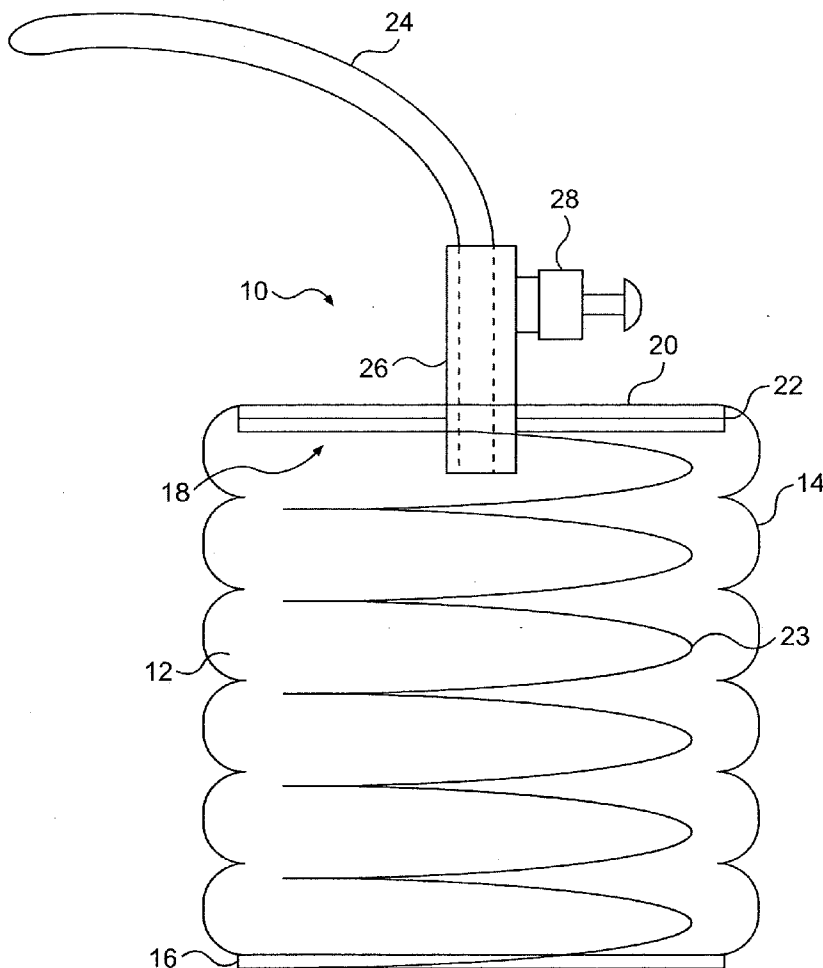

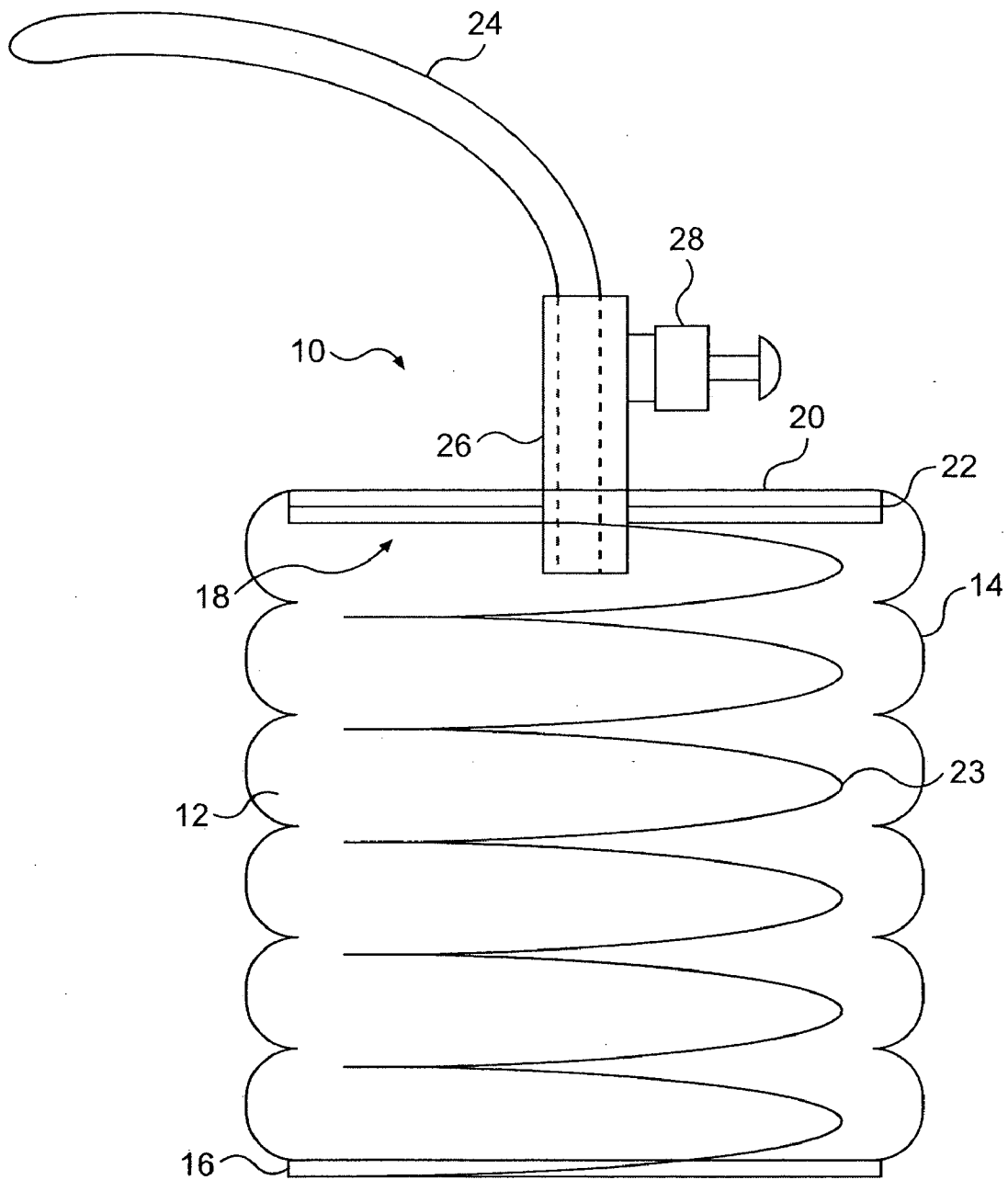

FIG. 1

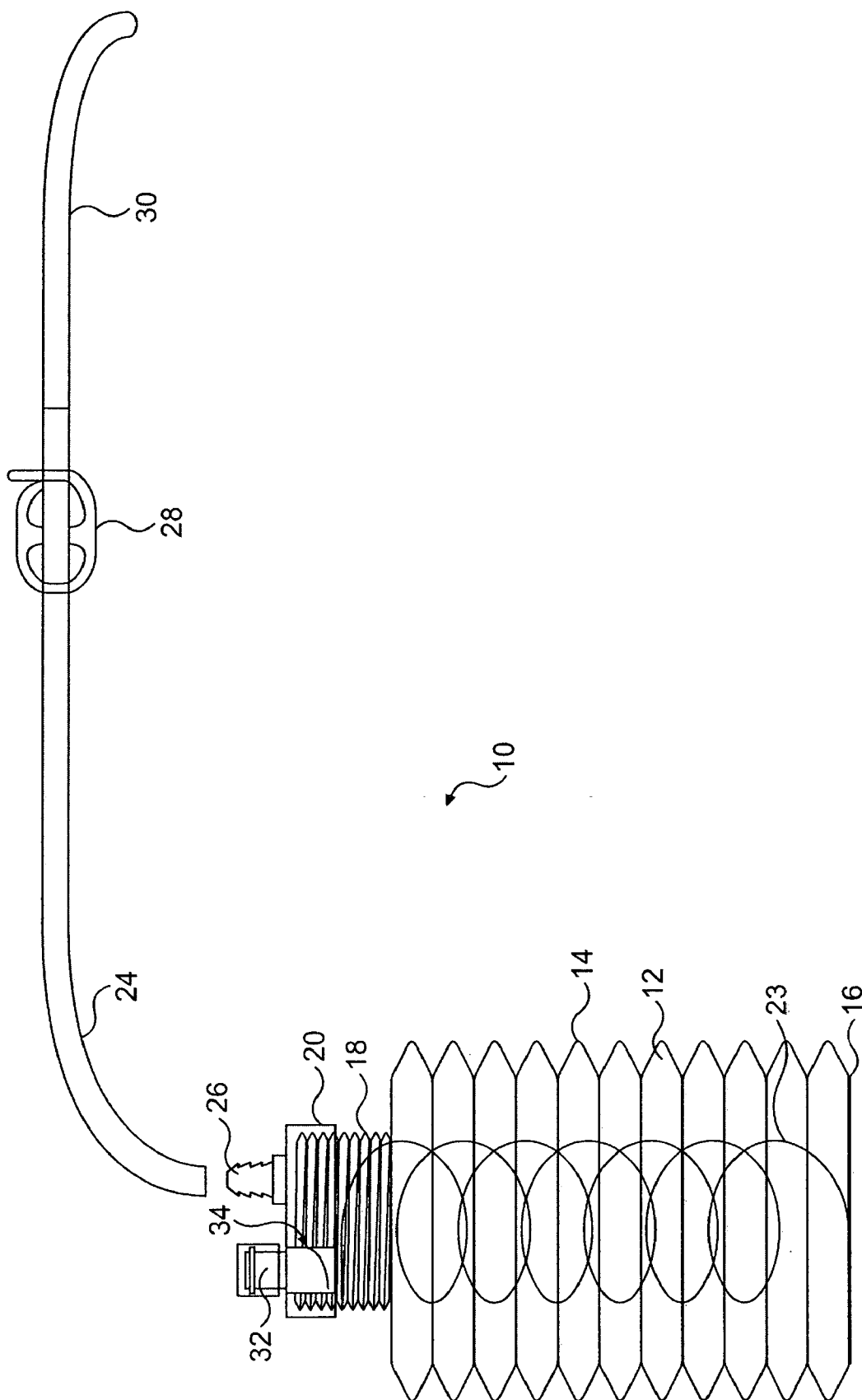

FIG. 2

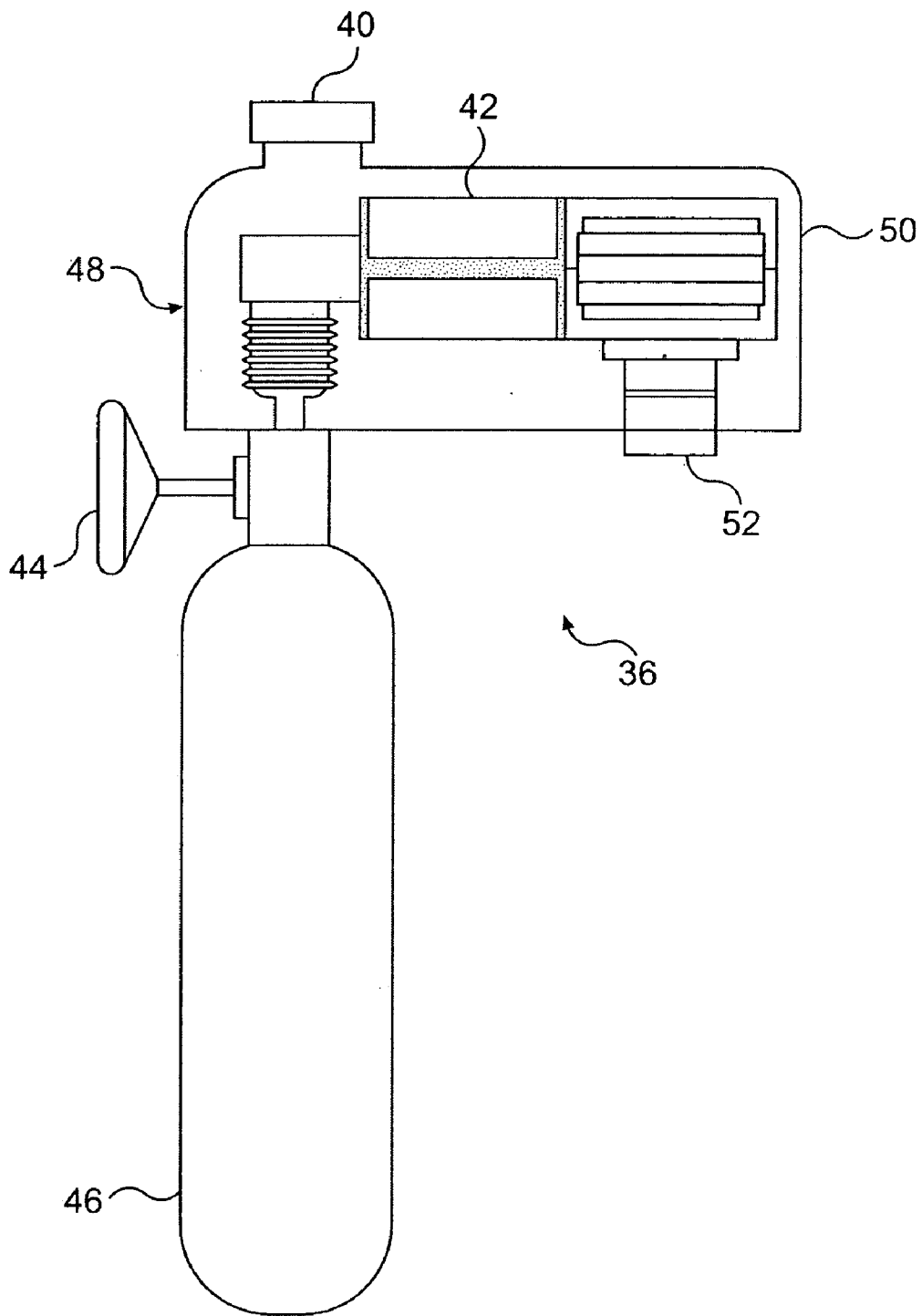

FIG. 3

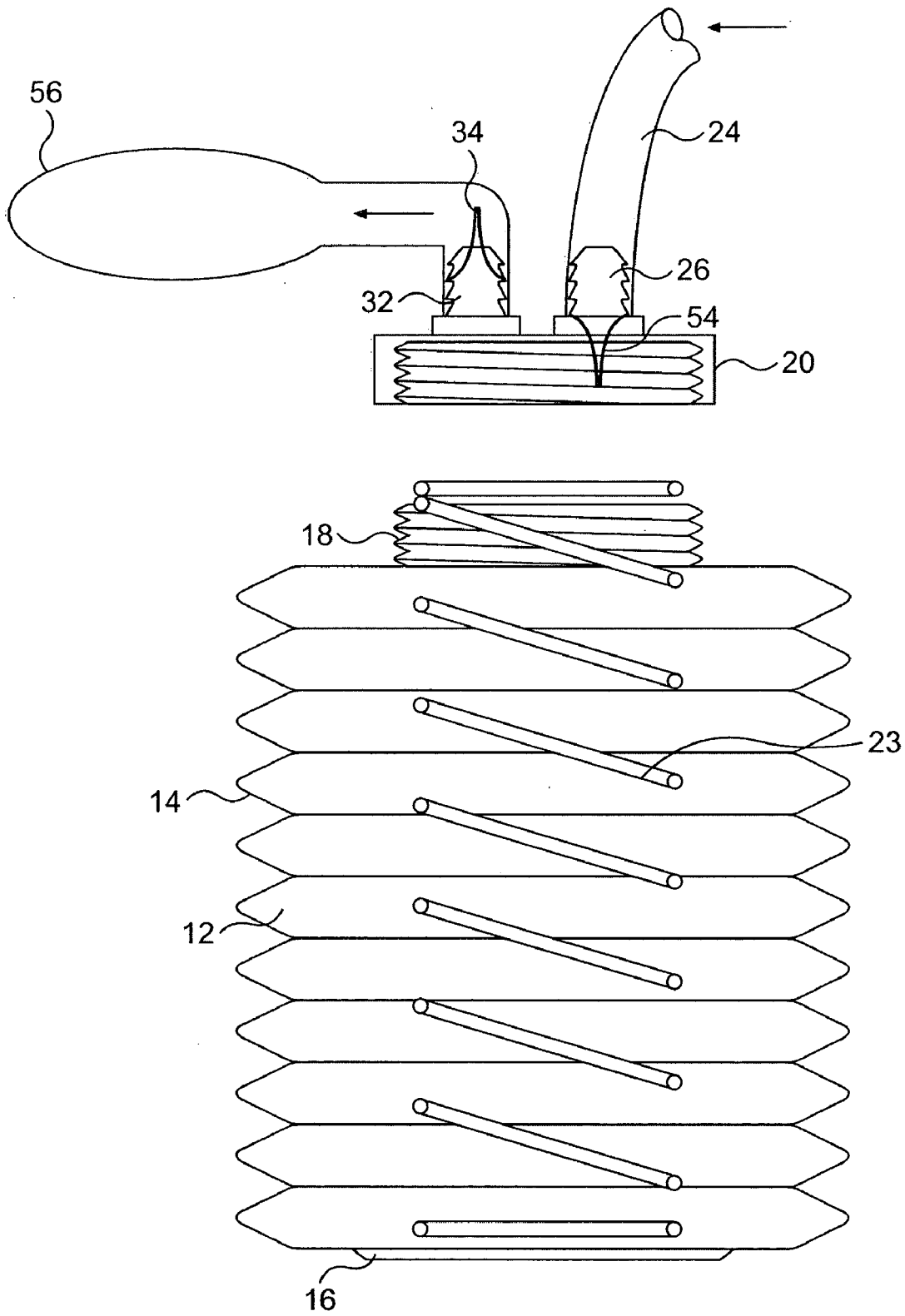

FIG. 4

PORTABLE VACUUM SYSTEM
CROSS-REFERENCE TO RELATED APPLICATIONS

[0001] The present application relates to, and is entitled to the benefit of the earlier filing date and priority of, Provisional Patent Application No. 60/429,079, filed Nov. 26, 2002.

FIELD OF THE INVENTION

[0002] The present invention relates to apparatus and methods for vacuuming and containing a plurality of materials. More particularly, it relates to apparatus and methods for vacuuming and containing medical, chemical and/or biological materials.

BACKGROUND

[0003] Medical, industrial, and military activities can involve the use or removal of chemical and biological substances in solid (e.g., powdered), liquid, or gaseous form, hereinafter referred to collectively as hazardous materials. For example, medical procedures may require the aspiration of biological fluids from a wound, or clean up of semi-solid medical waste. Industrial activities may require the recovery of a liquid, gas, or powdered chemical spill.

[0004] Typically, these substances must be handled with care. In some instances, these hazardous materials can be harmful to humans or the environment if they are not contained and disposed of properly. For example, biological material can be infectious, and chemical material may be poisonous, corrosive, or explosive. Small scale clean up of these substances can be disproportionately expensive due to the need to minimize the risk of exposure to the humans working with or around them. Accordingly, there is a continuing need to have a safe and efficient means for recovering and disposing of hazardous materials on a small scale basis.

[0005] Two of the known methods for small scale clean up of these substances are vacuuming and absorption. Both methods may require evacuation of the area surrounding the exposed substance, containment of the substance, collection of the substance, disposal of the substance, and decontamination of the equipment, personnel, and area involved in the recovery effort. The need to decontaminate equipment for reuse can be a particularly expensive and time intensive aspect of hazardous material clean up.

[0006] Vacuums have been employed to recover hazardous material. The use of vacuums, however, can present challenges. For instance, clean up of volatile material can present a risk of explosion. Many vacuums are electrically powered or controlled. The electrical components of a vacuum can produce a spark, which in turn, can ignite the volatile materials being collected.

[0007] Some vacuums often exhaust air in the process of drawing a vacuum. The exhaust air is drawn up with the hazardous material being collected. The hazardous material may be filtered out and the exhaust air returned to the environment. The vacuum exhaust may contain hazardous material vapors or particles, which are not trapped by the filter. As a result, the clean up effort may worsen contamination by the hazardous material rather than decrease it.

Further, vacuums that require the use of a filter may need to be disassembled and decontaminated after use. Decontamination may require replacement of some parts and the filter.

[0008] Hazardous materials collected by a vacuum may need to be disposed of after collection. Disposal may require that the hazardous materials be removed from the collection container associated with the vacuum, or at a minimum, this collection container must be disconnected from the vacuum. The process of transferring hazardous material to a disposal container, or even just disconnecting the collection container from the vacuum, can present a risk of further exposure to and/or loss of the hazardous material.

[0009] The performance of a vacuum also may be susceptible to failure due to occlusion of the suction passage. For example, in medical procedures, an occlusion may occur from the evacuation of tissues, debris, coagulating material, and/or solids. In some instances, an occlusion can prevent the system from evacuating the material from the desired location. In instances where suction is used in medical procedures, removing a suction catheter from a patient increases the patient's risk for infection and may form fluid filled abscesses.

[0010] The use of absorbents also may pose some challenges to effective clean up. Absorbent materials are typically placed upon a spill to remove as much material as possible. The remaining fluid is usually neutralized and the absorbent materials are collected, bagged, sealed and disposed of. Collection, bagging, and sealing must usually be carried out by hand. There may be added risk of exposure to the hazardous materials during these hand processes.

[0011] In some circumstances there is a need to analyze recovered material to determine its composition and whether or not it is hazardous. Such analysis may need to be carried out at a location distant from the collection site, and accordingly, there may be a need to safely transport the collected material to the analysis site. However, many vacuum systems are not capable of safely storing collected material for transport. As a result, collected material, which may be hazardous, may need to be transferred from the vacuum system to a storage container for transport, presenting yet another opportunity for release of hazardous material into the atmosphere.

[0012] In all of the above-mentioned methods, the recovery operation consists of multiple handling steps. Each step may increase the risk of exposure, spill or cross-contamination. Further, the risk of releasing air-borne particulates is exacerbated with each handling step. The risks associated with infectious air-borne particulates are evidenced by the incidence of hospital infections, which are significant.

[0013] Vacuums may also be used by medical practitioners to remove lodged solids or semi-solids from a patient's airway. Often such situations are emergencies and there may be a need to act relatively quickly to remove material from the patient's airway. A vacuum system that requires numerous parts, that is immobile, that requires a large electric powered vacuum, or that requires priming may cause a delay in action and decrease the patient's chances of survival or his ability to obtain oxygen and blood flow for critical organs.

[0014] Accordingly, there is a need for a vacuum system that is capable of addressing one or more of the above-mentioned challenges associated with prior vacuum systems.

SUMMARY OF THE INVENTION

[0015] Responsive to the foregoing challenges, Applicants have developed an innovative vacuum system comprising: a flexible container having a generally rigid base wall defining a first end of the container, a generally elongated and compressible cylindrical side wall extending away from said base wall, and an opening disposed at a second end of the container; a cap removably attached and sealed to the opening, said cap having a first coupler and including means for receiving a biasing force urging said cap away from said opening; a helically wound spring disposed within said container and extending between said cap and said base wall; an elongated tube connected to the first coupler; and a valve communicating with the elongated tube.

[0016] Applicants have further developed an innovative vacuum system for collecting, containing and disposing of material, the vacuum system comprising: a relatively flexible plastic bellows container adapted to selectively attain an expanded configuration and a compressed configuration, said container having a threaded opening and a base wall opposite the opening; a threaded cap connected to and forming a seal with the opening, said cap having a first coupler; a rigid cap member inserted into the cap; a helically wound spring disposed in said container and having a first end secured so as to be maintained adjacent to the base wall of the container and a second end biased against the cap member; a flexible suction tube connected to the first coupler; and a valve communicating with the suction tube, said valve adapted to control the ingress of material through the suction tube into the container.

[0017] Still further, Applicants have developed an innovative vacuum system for collecting, containing and disposing of material, the vacuum system comprising: a relatively flexible plastic bellows container adapted to selectively attain an expanded configuration and a compressed configuration, said container having a threaded opening and a base wall opposite the opening; a threaded cap connected to and forming a seal with the opening, said cap having integrally formed first and second barbed nipple couplers; a helically wound spring disposed in said container and having a first end secured so as to be maintained adjacent to the base wall of the container and a second end biased against the cap member, said spring providing a biasing force capable of achieving a vacuum pressure in excess of about 29 inches of mercury; a flexible suction tube connected to the first coupler; a valve communicating with the suction tube, said valve adapted to control the ingress of material through the suction tube into the container; a first one-way valve communicating with said second coupler, said one-way valve oriented so as to prevent the flow of fluid that passes through said second coupler back into the container; a second one-way valve communicating with the first coupler, said second one-way valve oriented so as to prevent the flow of fluid that passes through said first coupler back toward the suction tube; and a flexible exhaust receptacle connected and sealed to the second coupler.

[0018] It is to be understood that both the foregoing general description and the following detailed description are exemplary and explanatory only, and are not restrictive of the invention as claimed.

BRIEF DESCRIPTION OF THE DRAWINGS

[0019] In order to assist the understanding of this invention, reference will now be made to the appended drawings, in which like reference characters refer to like elements.

[0020] FIG. 1 is a pictorial view of a first embodiment of the present invention.

[0021] FIG. 2 is an exploded pictorial view of a second embodiment of the present invention.

[0022] FIG. 3 is a cross-sectional view of a vacuum motor attachment for use in one or more embodiments of the present invention.

[0023] FIG. 4 is a pictorial view of a third embodiment of the present invention.

DETAILED DESCRIPTION OF EMBODIMENTS OF THE INVENTION

[0024] Reference will now be made in detail to various embodiments of the present invention, examples of which are illustrated in the accompanying drawings. With reference to FIG. 1, a first embodiment of the vacuum system 10 is shown. The vacuum system 10 may include a relatively flexible elongated cylindrically-shaped bellows container 12. The generally cylindrically shaped side wall 14 of the container 12 may include a number of individual bellows which permit the container to be compressed and expanded along the axis of the cylindrically shaped side wall. The bellows may be formed so as to naturally assume an expanded position in a preferred embodiment, however, it is appreciated that this is not required for operation of the bellows.

[0025] The container 12 may include a relatively rigid base 16 at a first end. The rigid base 16 may be integrally formed with the container, or it may be inserted into the bottom of the container, or it may be attached to the exterior of the container. The rigid base 16 may be adapted to bear the loading applied to the base of the container by a spring or other biasing device provided in the container.

[0026] The container 12 may include an opening 18 at a second end opposite the first end of the container. The opening 18 may be adapted to receive and engage a cap 20. Preferably, the opening 18 and the cap 20 may be threaded and adapted to form a secure seal with each other when properly connected. The cap 20 may be relatively rigid, and/or it may include a relatively rigid cap insert 22 to strengthen the cap. Preferably the container 12 and the cap 20 may be constructed of plastic, and most preferably from HDPE.

[0027] A spring 23 may be provided inside the container 12. The spring 23 may apply a biasing force against the cap 20 and the base 16 of the container. The force applied by the spring 23 may bias the container into an expanded position. Preferably, the spring 23 may apply a relatively constant biasing force throughout the travel of the spring between compressed and expanded positions. Preferably, the spring 23 may provide a biasing force capable of achieving a vacuum pressure in excess of about 29 inches of mercury in operation.

[0028] A suction tube 24 may be attached to the cap 20 by a coupler 26. A control valve 28 may be used to selectively

open and close the suction tube 24. The suction tube 24 may be relatively flexible and may include a more rigid tip adapted to suction powders, fluids, and/or gases. The coupler 26 may be integrally formed with the cap 20 or connected to the cap. The coupler 26 should be sufficiently secured and sealed to the cap 20 to prevent the escape of collected material from the container 12.

[0029] The vacuum system 10 shown in FIG. 1 may be used to generate a vacuum pressure sufficient to collect, in various example embodiments, medical, biological and/or chemical material. Medical, biological and/or chemical material may be, but not limited to, blood, tissue, body fluids, saline solutions, clots, chemical and/or hazardous solutions, flowable liquids, emulsions, solids, semi-solids or any other mixture or element involved in medical, biological and/or chemical areas. The vacuum system may be used by opening the control valve 28 and manually compressing the spring 23 and bellows so that air in the container 12 is forced out through the suction tube 24. The control valve 28 may then be closed so that the container 12 remains in a compressed position until suction is needed. When suction is needed, the control valve 28 may be selectively opened, which permits a vacuum to be drawn through the suction tube 24 as the container 12 is urged to expand under the influence of the spring 23. As the container 12 expands, material may be drawn against or through the suction tube 24 into the container. The bellows may be recompressed as necessary to draw additional material against the suction tube or into the container. When the container is full, or vacuuming is completed, the control valve 28 may be closed and the entire vacuum system 10 may be disposed of or stored.

[0030] A second embodiment of the present invention is illustrated in FIG. 2 in which like reference characters refer to like elements shown in FIG. 1. With reference to FIG. 2, the suction tube 24 is provided with an alternatively designed control valve 28. It is appreciated that various types of control valves may be used without departing from the intended scope of the present invention. The suction tube 24 also may be provided with a rigid suction tip 30.

[0031] With continued reference to FIG. 2, the cap 20 may be precision threaded with an integrated compression seal produced by an injection molding process to seal the container at the opening 18. The cap 20 may be provided with first and second couplers 26 and 32. The first coupler 26 may comprise a barbed nipple. The suction tube 24 may be press fit or screwed onto the barbed nipple so that a tight seal is formed between the first coupler 26 and the suction tube. The second coupler 32 may be adapted to connect to a vacuum motor 36, such as shown in FIG. 3, or an exhaust receptacle 38, such as shown in FIG. 4. The second coupler 32 may incorporate a one-way valve 34 that permits exhaust material to flow out of the container 12 past the second coupler, but does not permit material to flow in reverse through the second coupler into the container. Exhaust material may include air drawn through the vacuum system when the container 12 is compressed, or hazardous material collected by the vacuum system 10. When the exhaust material includes hazardous material, it may be advisable to attach an exhaust receptacle to the second coupler, as explained below in connection with the description of the embodiment of the invention shown in FIG. 4. The one-way valve 34 shown in FIG. 2 is a flapper-type valve and is

intended to be exemplary only. It is appreciated that alternative types of one-way valves may be used without departing from the intended scope of the present invention.

[0032] The vacuum system 10 shown in FIG. 2 may be used by manually compressing the spring 23 and bellows so that air in the container 12 is forced out through either the suction tube 24 (if the control valve 28 is open), or the second coupler 32 if the control valve is closed, or through both the suction tube and the second coupler. Once the container 12 is compressed, the control valve 28 may be closed so that the container 12 remains in a compressed position until suction is needed. When suction is needed, the control valve 28 may be selectively opened which permits a vacuum to be drawn through the suction tube 24 as the container 12 expands under the influence of the spring 23. As the container 12 expands, material may be drawn through the suction tube 24 into the container. The bellows may be recompressed as necessary to draw additional material into the container. When the bellows are recompressed, exhaust air or other exhaust material may be forced out of the container 12 past the second coupler 32 into an exhaust receptacle (shown in FIG. 4) or into the ambient. When the container 12 is full, or vacuuming is completed, the control valve 28 may be closed and the entire vacuum system 10 may be disposed of or stored.

[0033] The vacuum motor 36, depicted in FIG. 3, may include a CO₂ cylinder 46, an air motor 48, a rotary vane vacuum pump 50, a quick connect fitting 52, a HEPA filter exhaust 40, a coupler 42, and a valve 44. The vacuum motor 36 may be used alternatively or in addition to the spring shown in FIG. 2. In some embodiments, the vacuum motor 36 may be adjustable to produce variable vacuum pressures and produce a sufficient vacuum pressure so as to dislodge an occlusion in an airway and/or efficiency contain a bio-hazard spill.

[0034] A third embodiment of the present invention is illustrated in FIG. 4 in which like reference characters refer to like elements shown in FIGS. 1, 2, and 3. With reference to FIG. 4, the cap 20 is provided with one-way valves 34 and 54 which permit the flow of material into the container 12 past the first coupler 26, and out of the container past the second coupler 32, but do not readily permit reverse flow. Exhaust material may be collected in an exhaust receptacle 56 which is preferably flexible, and more preferably expandable, such as a balloon. The exhaust receptacle 56 may be sealed to the second coupler 32 to prevent the escape of exhaust material or collected material into the ambient.

[0035] It will be apparent to those skilled in the art that variations and modifications of the present invention can be made without departing from the scope or spirit of the invention. Numerous characteristics and advantages have been set forth in the foregoing description, together with details of structure and function. The novel features are pointed out in the appended claims. The disclosure, however, is illustrative only, and changes may be made in detail, especially in matters of the shape, size and arrangement of parts, within the principle of the invention, to the full extent indicated by the broad general meaning of the terms in which the appended claims are expressed.

What is claimed is:

1. A vacuum system comprising:
 - a flexible container having a generally rigid base wall defining a first end of the container, a generally elongated and compressible cylindrical side wall extending away from said base wall, and an opening disposed at a second end of the container;
 - a cap removably attached and sealed to the opening, said cap having a first coupler and including means for receiving a biasing force urging said cap away from said opening;
 - a helically wound spring disposed within said container and extending between said cap and said base wall;
 - an elongated tube connected to the first coupler; and
 - a valve communicating with the elongated tube.
2. The system of claim 1 further comprising:
 - a second coupler disposed on said cap; and
 - a one-way valve communicating with said second coupler, said one-way valve oriented so as to prevent the flow of fluid that passes through said second coupler back into the container.
3. The system of claim 1 further comprising a compressed gas powered vacuum motor connected to said second coupler.
4. The system of claim 1 further comprising an expandable exhaust receptacle connected to said second coupler.
5. The system of claim 1 further comprising a rigid base member disposed in the container between the spring and the base wall.
6. The system of claim 1 wherein the means for receiving a biasing force comprises a rigid cap member disposed in the container between the cap and the spring.
7. The system of claim 1 wherein the spring is adapted to provide a biasing force capable of achieving a vacuum pressure in excess of about 29 inches of mercury.
8. A vacuum system for collecting, containing and disposing of material, the vacuum system comprising:
 - a relatively flexible plastic bellows container adapted to selectively attain an expanded configuration and a compressed configuration, said container having a threaded opening and a base wall opposite the opening;
 - a threaded cap connected to and forming a seal with the opening, said cap having a first coupler;
 - a rigid cap member inserted into the cap;
 - a helically wound spring disposed in said container and having a first end secured so as to be maintained adjacent to the base wall of the container and a second end biased against the cap member;
 - a flexible suction tube connected to the first coupler; and
 - a valve communicating with the suction tube, said valve adapted to control the ingress of material through the suction tube into the container.
9. The system of claim 8 further comprising:
 - a second coupler disposed on said cap; and
 - a one-way valve communicating with said second coupler, said one-way valve oriented so as to prevent the flow of fluid that passes through said second coupler back into the container.
10. The system of claim 9 further comprising a rigid base member disposed in the container between the spring and the base wall.
11. The system of claim 10 wherein the spring is adapted to provide a biasing force capable of achieving a vacuum pressure in excess of about 29 inches of mercury.
12. The system of claim 11 further comprising a compressed gas powered vacuum motor connected to said second coupler.
13. The system of claim 11 further comprising an expandable exhaust receptacle connected to said second coupler.
14. The system of claim 2 further comprising a second one-way valve communicating with the first coupler, said second one-way valve oriented so as to prevent the flow of fluid that passes through said first coupler back toward the elongated tube.
15. The system of claim 9 further comprising a second one-way valve communicating with the first coupler, said second one-way valve oriented so as to prevent the flow of fluid that passes through said first coupler back toward the suction tube.
16. A vacuum system for collecting, containing and disposing of material, the vacuum system comprising:
 - a relatively flexible plastic bellows container adapted to selectively attain an expanded configuration and a compressed configuration, said container having a threaded opening and a base wall opposite the opening;
 - a threaded cap connected to and forming a seal with the opening, said cap having integrally formed first and second barbed nipple couplers;
 - a helically wound spring disposed in said container and having a first end secured so as to be maintained adjacent to the base wall of the container and a second end biased against the cap member, said spring providing a biasing force capable of achieving a vacuum pressure in excess of about 29 inches of mercury;
 - a flexible suction tube connected to the first coupler;
 - a valve communicating with the suction tube, said valve adapted to control the ingress of material through the suction tube into the container;
 - a first one-way valve communicating with said second coupler, said one-way valve oriented so as to prevent the flow of fluid that passes through said second coupler back into the container;
 - a second one-way valve communicating with the first coupler, said second one-way valve oriented so as to prevent the flow of fluid that passes through said first coupler back toward the suction tube; and
 - a flexible exhaust receptacle connected and sealed to the second coupler.