

P. C. JOHNSON.  
Hoisting-Machine

No. 199,071.

Patented Jan. 8, 1878.

Fig. 1.

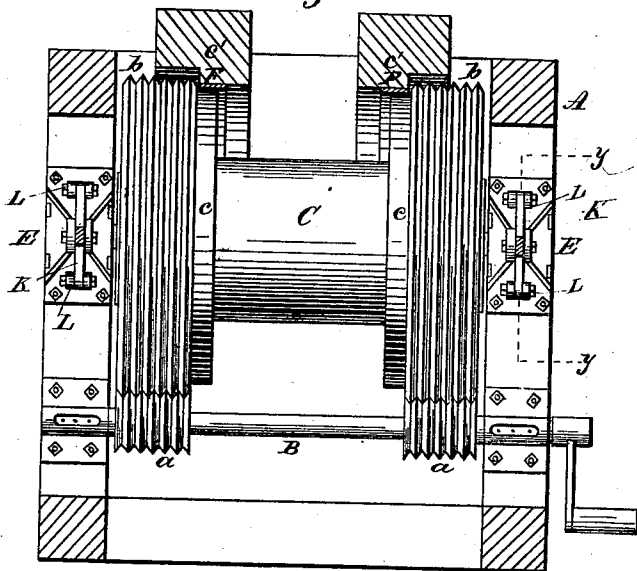

Fig. 2.

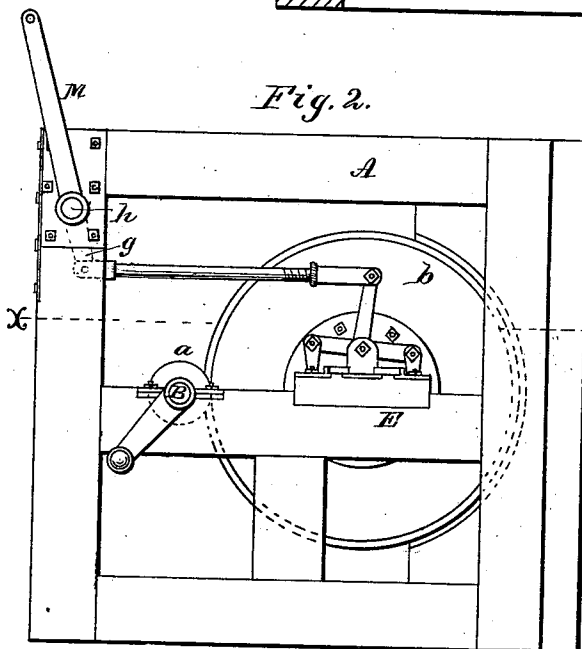
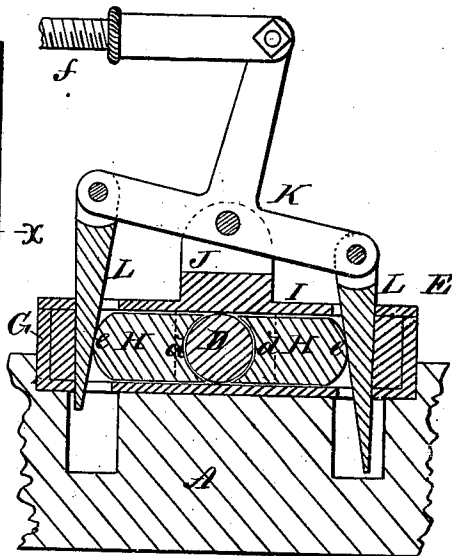

Fig. 3.



WITNESSES:

*Henry N. Miller*  
*J. H. Scarborough.*

INVENTOR:

*P. C. Johnson.*  
BY *Mumford*

ATTORNEYS.

P. C. JOHNSON.  
Hoisting-Machine.

No. 199,071.

Patented Jan. 8, 1878.

Fig. 4.

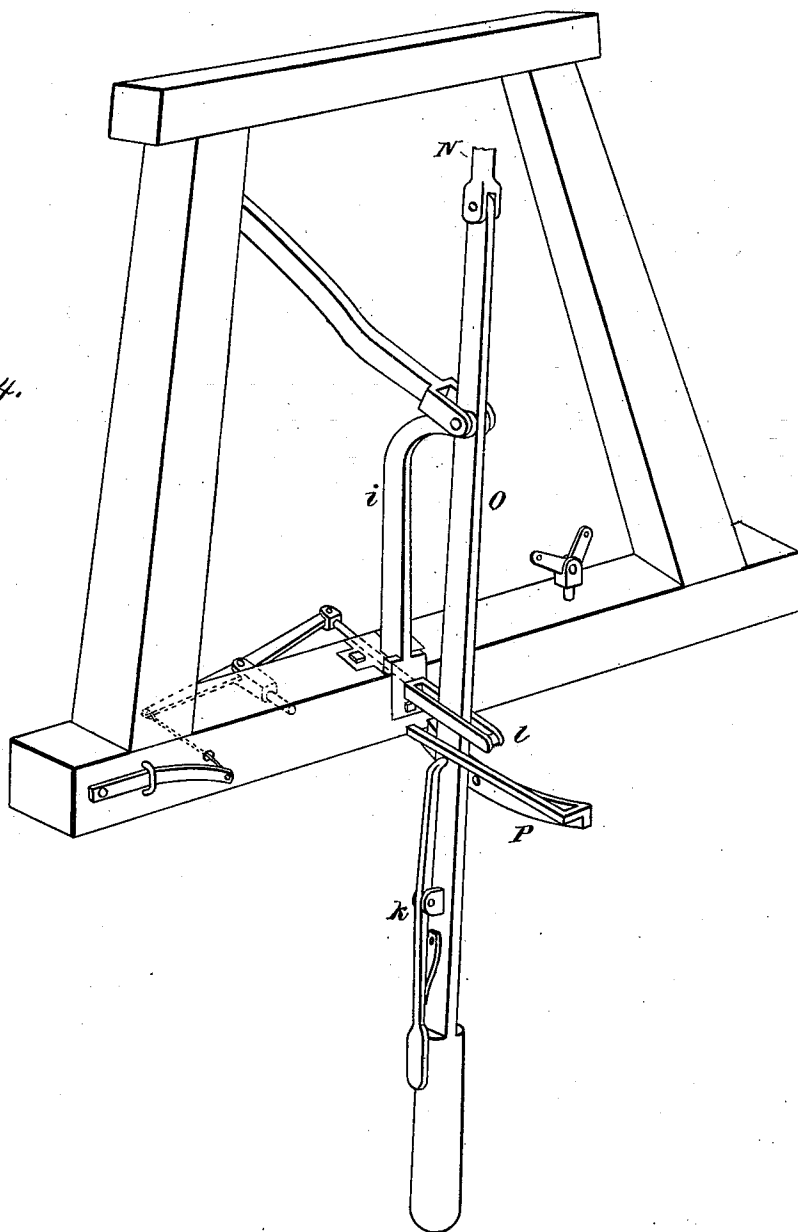

WITNESSES:

Henry W. Miller  
J. H. Scarborough.

INVENTOR:

P. C. Johnson  
BY                       
ATTORNEYS.

# UNITED STATES PATENT OFFICE.

PETER C. JOHNSON, OF BLACK HAWK, COLORADO.

## IMPROVEMENT IN HOISTING-MACHINES.

Specification forming part of Letters Patent No. **199,071**, dated January 8, 1878; application filed November 22, 1877.

### *To all whom it may concern:*

Be it known that I, PETER C. JOHNSON, of Black Hawk, in the county of Gilpin and State of Colorado, have invented a new and Improved Hoisting-Machine, of which the following is a specification:

Figure 1 is a plan view, taken in section on line *x x* in Fig. 2. Fig. 2 is a side elevation. Fig. 3 is a detail sectional view, taken on line *y y* in Fig. 1. Fig. 4 is a perspective view of a part of the frame of the hoisting-machinery, having attached to it the levers for throwing the machinery into and out of gear.

Similar letters of reference indicate corresponding parts.

My invention consists in an arrangement of wedges and levers for shifting the winding-drum of a hoisting-machine into and out of gear, and also into and out of contact with the brake-shoes; the object being to provide a simple and reliable means for shifting the apparatus from hoisting to braking.

Referring to the drawings, A is the frame that supports the several parts of the hoisting apparatus. B is the driving-shaft, carrying two small grooved friction-wheels, *a*, one near each end; and C is the winding-drum, having at its end grooved friction-wheels *b*, that are driven by the smaller friction-wheels *a*.

The drum C and wheels *b* are secured to a shaft, D, which revolves in boxes E, secured to the frame A. The wheels *b* are composed of pieces of wood, the grain of which extends in a radial direction. On one side of each wheel *b* a friction-wheel, *c*, is formed, which revolves in close proximity to the copper-faced brake-shoe F, which is fastened to the frame.

The box E consists of a rectangular casing, G, containing two similar blocks, H, one on each side of the shaft, each having a concave face, *d*, that is placed in contact with the shaft D, and a convex face, *e*, that is acted upon by the shifting-wedge. The box E is provided with a cap, I, that is fastened by means of bolts in the usual way. A forked standard, J, projects from the center of the cap I, and in it is fulcrumed the T-lever K. The cap I and the casing G are apertured to receive wedges L, which are pivoted to opposite arms of the T-lever K. These wedges are backed by a filling of Babbitt metal in the ends of the

casing G, which holds them up into engagement with the rounded ends of the blocks H.

The upper arm of the T-lever K is connected by a rod, *f*, with an arm, *g*, on the rock-shaft *h*, which is journaled at the front of the frame A, and is provided at one end with the lever M.

The boxes E are alike on both ends of the shaft D, and their levers K are both connected with arms *g* on the rock-shaft *h*, so that both ends of the shaft D are moved simultaneously when the rock-shaft *h* is turned.

By moving the lever M toward the hoisting-drum the forward wedges are forced into the boxes E between the end of the casing G and the blocks H, moving the shaft D and wheels and drum supported by it away from the shaft B. The drum being thus released is free to rotate, unless the movement of the lever M is continued until the friction-wheels *c* are thrown into contact with the brake-shoes *c'*, when the motion may be controlled at pleasure. By reversing the movement of the lever M the drum is moved forward, so as to release the friction-wheels from the brake-shoes, and throw the grooved friction-wheels *b* into contact with the driving-wheels *a*.

The lever M is connected by a rod, N, with a lever, O, that is fulcrumed in a standard, *i*, secured to the frame-work that supports the sheave over which the hoisting-rope runs down into the mine. This lever moves along the curved bar P, that projects from the said frame, and is provided with a spring latch-lever, *k*, that engages a hole in the curved bar P when the two sets of friction-wheels are thrown into contact. When the lever O is moved so as to throw the friction-gearing out of contact, it draws forward the loop *l*, which is connected by means of a suitable arrangement of levers and wire with the engine-valve, and releases the engine-valve, which is closed by means of a weight or spring. By moving the lever O in the opposite direction the engine-valve is opened.

By means of my improvements the hoisting-drum is placed completely under the control of a single man.

Having thus described my invention, I claim as new and desire to secure by Letters Patent—

1. The movable winding-drum C, having at

each end a grooved friction-wheel, *b*, and brake-wheel *c*, and the metal-faced brake-shoes *c'*, in combination, as herein shown and described.

2. The combination, in a journal-box for hoisting-machinery, of the side bearing-pieces *H* and the wedges *L*, as herein shown and described.

3. The combination of the **T**-levers *K*, connecting-rods *f*, and shaft *h*, having arms *g*,

with the wedges *L*, for operating the movable bearing-pieces *H*, as herein shown and described.

4. The combination of the hand-lever *O* with the wedge-operating levers, as herein shown and described.

PETER CHRISTIAN JOHNSON.

Witnesses:

S. H. BRADLEY,  
J. S. CHAPLINE.