

March 31, 1964

H. S. MEYERS
DISPENSING PACKAGE
Filed Oct. 23, 1961

3,127,054

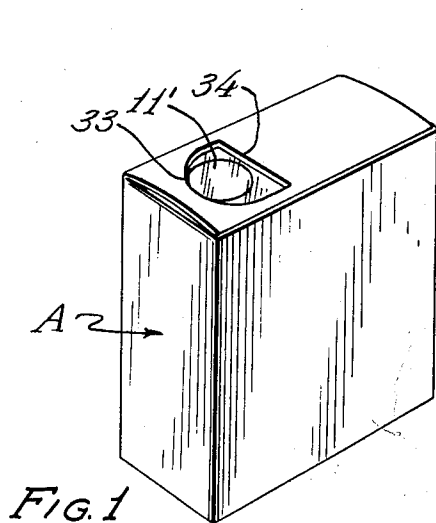

FIG. 1

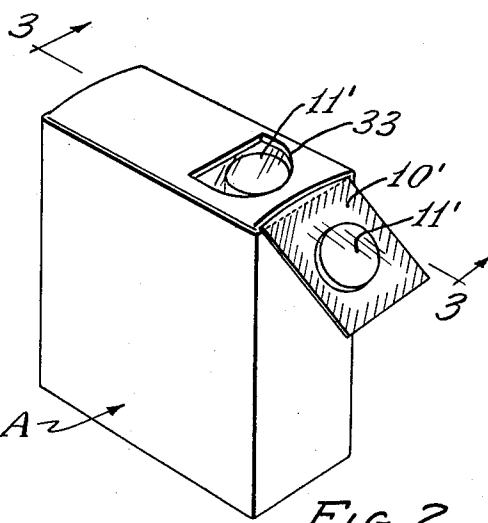

FIG. 2

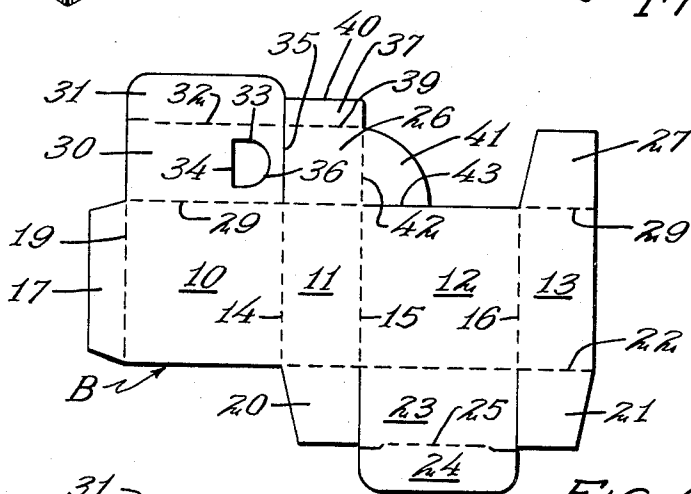

FIG. 4

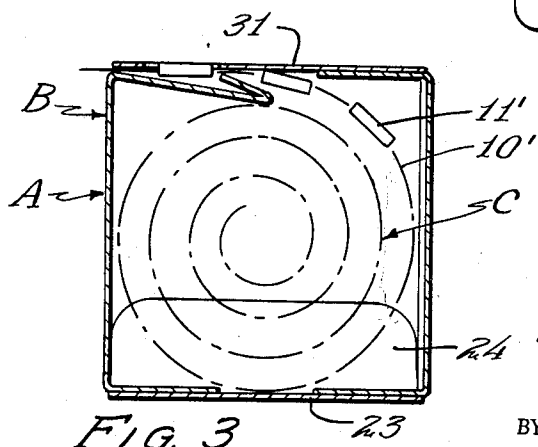

FIG. 3

INVENTOR
HAROLD S. MEYERS
BY *Robert M. Dunning*
ATTORNEY

1

3,127,054

DISPENSING PACKAGE

Harold S. Meyers, Minneapolis, Minn., assignor to
Waldorf Paper Products Company, Ramsey County,
Minn., a corporation of Minnesota

Filed Oct. 23, 1961, Ser. No. 146,799

1 Claim. (Cl. 221-25)

This invention relates to an improvement in dispensing package and deals particularly with a package for dispensing products which are sealed in spaced relation between a pair of strips.

During recent years it has become common practice to seal various items between spaced layers of heat sealable material such as plastic sheeting, coated foil and the like. This is particularly true in the case of pills, pellets, lozenges, and the like which may be adversely affected by moisture in the atmosphere. It is an object of the present invention to provide a simple package designed to contain an elongated strip containing a series of such objects sealed in spaced relation between a pair of layers and wound in spiral form. The package is so arranged that the product may be withdrawn one at a time as the product is used.

A feature of the present invention resides in the provision of a dispensing package having a closure having a tuck end type including a pair of opposed flaps, and an intermediate closure panel provided with a tuck flap which may be folded over the opposed flaps to enclose the same. An end of the coiled strip extends between this cover or closure panel and one of the first folded flaps where it may be grasped and drawn from the package.

A feature of the present invention resides in the provision of an aperture in the cover flap to expose a portion of the strip therebeneath. This aperture serves the double purpose of making the strip available, and also of permitting the pellet, lozenge, or the like to extend partially through the aperture. The aperture is slightly larger than the products being dispensed, and the edge of the aperture serves as a shoulder to resist movement of the strip in either direction. The strip may be drawn from the package by urging the enlarged pellet or lozenge outwardly until the end of the strip may be grasped between the fingers and pulled out. The strip is usually pulled out until the next pellet or lozenge engages in the aperture and the end of the strip containing a pellet or lozenge is torn off. The next pellet or lozenge engages in the aperture and resists the return movement of the end of the strip into the carton.

A further feature of the present invention resides in the provision of a means for preventing the flap over which the strip is dispensed from flexing down into the interior of the package. A flap is hinged to an edge of the closing flap and engages the wall to which the closing flap is hinged, to limit the inward swinging of the closing flap.

A further feature of the present invention resides in the provision of a terminal flange on the closing flap over which the strip is dispensed which is folded to overlie the closing flap with the end of the flange in opposed relation to an edge of the aperture. The end of the flange cooperates with the edge of the aperture to prevent the return movement of the strip into the package.

These and other objects and novel features of the present invention will be more clearly and fully set forth in the following specification and claims.

In the drawings forming a part of the specification:

FIGURE 1 is a perspective view of the dispensing carton in closed position.

FIGURE 2 is a view similar to FIGURE 1 showing a portion of the strip being drawn from the package.

FIGURE 3 is a sectional view through the package,

2

the position of the section being indicated by the line 3-3 of FIGURE 2.

FIGURE 4 is a diagrammatic view of the blank from which the package is formed.

The dispensing package A includes the outer enclosure which is indicated in general by the letter B and the spirally wound strip of material to be dispensed, which is indicated in general by the letter C. In preferred form, the strip to be dispensed includes a pair of contiguous strips of heat sealable material which are indicated in general by the numeral 10' and between which are sealed a series of spaced pellets, lozenges, or the like which are indicated in general by the numeral 11'. The strip containing the product is normally wound in spiral form as indicated in FIGURE 3 of the drawings.

The outer enclosure B includes, in series, a side wall 10, and an end wall 11, a side wall 12, and a second end wall 13, which are connected along parallel fold lines 14, 15, and 16. A glue flap 17 is connected to the side wall 10, by the fold line 19. In the formation of the carton, the glue flap 17 is adhered in face contact with the end wall panel 13 to form a rectangular tube.

The bottom closure of the carton is of conventional form. A pair of end wall flaps 20 and 21 are connected to the lower edges of the end walls 11 and 13 along a fold line 22. A closure panel 23 is foldably connected to the side wall 12 along the fold line 22.

A tuck flap 24 is hinged to the closure panel 23 along a fold line 25 which is spaced from the fold line 22 a distance substantially equal to the width of the end walls 11 and 13.

A pair of inner closing flaps 26 and 27 are foldably connected to the upper edges of the end walls 11 and 13 along aligned fold lines 29. A top closure panel 30 is foldably connected to the upper edge of the side wall 10 along the fold line 29. A tuck flap 31 is hinged to the free edge of the closure panel 30 along the fold line 32. The fold line 32 is spaced from the fold line 29 a distance substantially equal to the width of the end walls 11 and 13.

An aperture 33 is provided in the closure panel 30 and in the portion thereof which will overlie the closing flap 26 when the carton is closed. While the shape of the aperture 33 may be varied, in the particular arrangement illustrated, the aperture 33 is defined by a transverse cut line 34 which is in spaced parallel relation to the end edge 35 of the closure flap and by a U-shaped cut line 36 having its end in communication with the ends of the cut line 34. The aperture 33 is preferably centered between the fold lines 29 and 32.

The closing flap 26 is provided with a terminal flange 37 foldably connected to the free end of the flap 26 along a fold line 39. The flap 26 and flange 37 are so proportioned that when the flange 37 is folded to overlie the flap 26 and the carton is closed, the free edge 40 of the flange 37 will substantially coincide with the straight edge 34 of the aperture 33. The purpose of this arrangement will be described.

A flange or supporting flap 41 is hingedly connected along a fold line 42 which is substantially aligned with the fold line 15 to the flange 26. The supporting flap 41 is provided with an edge 43 which is at substantially right angles to the fold line 42.

In the use of the package, the blank is adhered in tubular form by attaching the glue flap 17 to the end panel 13. The bottom closure is closed by folding the flaps 20 and 21 into a common plane, folding the closure panel 23 to underlie the flaps 20 and 21, and tucking the tuck flap 24 between the edges of the flaps 20 and 21 and the side wall 10. The roll of product C is then inserted into the package. The supporting flap 41 is folded into right angular relation to the flap 26, and the flap 26

is folded across the end of the carton. The flange 37 is doubled back upon the flap 26 and the end of the strip C is drawn over the flange 37 and flap 26 until the edge of one of the pellets or lozenges 11' is in engagement with the free edge 40 of the flange 37. The opposite flap 27 is folded down into the plane of the flap 26, and the closure flap 30 is then folded down, the tuck flap 31 being inserted between the supporting flange 41 and the side wall 12, and between an edge of a flap 27 and the side wall 12.

The supporting flange 41 thus holds the flange 26 from flexing any substantial distance into the interior of the carton. At the same time, the enlarged pill or pellet 11' extends partially through the aperture 33, the edge of the pill or pellet engaging the free edge 40 of the flange 37 and the edge 34 of the aperture 33 so that the strip will not be retracted back into the carton.

When it is desired to use one of the pills or pellets 11', the rear edge of this enlarged portion of the strip is engaged by the finger and pushed outwardly toward the position illustrated in FIGURE 2, the top closure panel 30 flexing sufficiently to prevent the product from passing between the closure panel and the flap 26. When the edge of the strip is exposed, it may be grasped and pulled into the position illustrated in FIGURE 2, when the next subsequent pill or pellet 11' is in registry with the aperture 33. The strip may then be torn or cut off and the product removed for use.

In accordance with the patent statutes, I have described the principles of construction and operation of my improvement in "dispensing package," and while I have endeavored to set forth the best embodiment thereof, I desire to have it understood that changes may be made within the scope of the following claims without departing from the spirit of my invention.

I claim:

A carton in combination with a spiral roll of material to be dispensed, the roll including pellets sealed in spaced relation between strips of flexible material forming a tape, the carton including a one piece enclosure comprising side and end walls forming a sleeve, the side walls being of dimensions slightly greater than the diameter of the roll and the end walls being of a width slightly greater than the width of the roll, a first end closure closing one end of said sleeve and a second end closure closing the opposite end thereof, said second end closure including a pair of closure flaps hinged to the end walls and folded inwardly therefrom, a closure panel hinged to one of said side walls and folded to overlie said first named closure flaps, a tuck flap on said closure panel folded inwardly of the other side wall, an aperture in the portion of said closure panel overlying one of said first named closure flaps, the end of the strip extending between said closure panel and said one closure flap, the pellets sequentially extending partially through said aperture to resist movement of said tape in either direction, a flap hinged to a side edge of said one closure flap parallel to and adjoining, one of said side walls and in face contact thereto, said last named flap having an edge arranged at right angles to the line of fold connecting the same to said one closure flap and abutting against the end wall to which said one closure flap is secured to hold said one closure flap from flexing inwardly.

References Cited in the file of this patent

UNITED STATES PATENTS

2,771,214	Lefebvre	Nov. 20, 1956
2,984,397	Gillam	May 16, 1961
3,001,643	O'Meara et al.	Sept. 26, 1961