



INTERNATIONAL APPLICATION PUBLISHED UNDER THE PATENT COOPERATION TREATY (PCT)

(51) International Patent Classification ⁶ : G01N 27/447	A1	(11) International Publication Number: WO 99/24827 (43) International Publication Date: 20 May 1999 (20.05.99)
<p>(21) International Application Number: PCT/US98/23661</p> <p>(22) International Filing Date: 6 November 1998 (06.11.98)</p> <p>(30) Priority Data: 08/965,738 7 November 1997 (07.11.97) US</p> <p>(71) Applicant: THE REGENTS OF THE UNIVERSITY OF CALIFORNIA [US/US]; 22nd floor, 300 Lakeside Drive, Oakland, CA 94612-3550 (US).</p> <p>(72) Inventors: SIMPSON, Peter, C.; 95 Linda Avenue #308, Oakland, CA 94611 (US). MATHIES, Richard, A.; 93 Dane-field Place, Moraga, CA 94556-1224 (US). WOOLLEY, Adam, T.; Apartment #1, 45 Dartmouth Street, Belmont, MA 02178-3643 (US).</p> <p>(74) Agent: EGAN, William, J., III; Fish & Richardson P.C., Suite 100, 2200 Sand Hill Road, Menlo Park, CA 94025 (US).</p>	<p>(81) Designated States: AL, AM, AT, AU, AZ, BA, BB, BG, BR, BY, CA, CH, CN, CU, CZ, DE, DK, EE, ES, FI, GB, GD, GE, GH, GM, HR, HU, ID, IL, IS, JP, KE, KG, KP, KR, KZ, LC, LK, LR, LS, LT, LU, LV, MD, MG, MK, MN, MW, MX, NO, NZ, PL, PT, RO, RU, SD, SE, SG, SI, SK, SL, TJ, TM, TR, TT, UA, UG, UZ, VN, YU, ZW, ARIPO patent (GH, GM, KE, LS, MW, SD, SZ, UG, ZW), Eurasian patent (AM, AZ, BY, KG, KZ, MD, RU, TJ, TM), European patent (AT, BE, CH, CY, DE, DK, ES, FI, FR, GB, GR, IE, IT, LU, MC, NL, PT, SE), OAPI patent (BF, BJ, CF, CG, CI, CM, GA, GN, GW, ML, MR, NE, SN, TD, TG).</p> <p>Published <i>With international search report.</i></p>	

(54) Title: MICROFABRICATED CAPILLARY ARRAY ELECTROPHORESIS DEVICE AND METHOD

(57) Abstract

A capillary array electrophoresis (CAE) micro-plate with an array of separation channels (50) connected to an array of sample reservoirs (101) on the plate. The sample reservoirs (101) are organized into one or more sample injectors (100-116). One or more waste reservoirs are provided to collect wastes from reservoirs in each of the sample injectors. Additionally, a cathode reservoir (120) is also multiplexed with one or more separation channels. To complete the electrical path; an anode reservoir (180) which is common to some or all separation channels is also provided on the micro-plate. Moreover, the channel layout keeps the distance from the anode to each of the cathodes approximately constant.

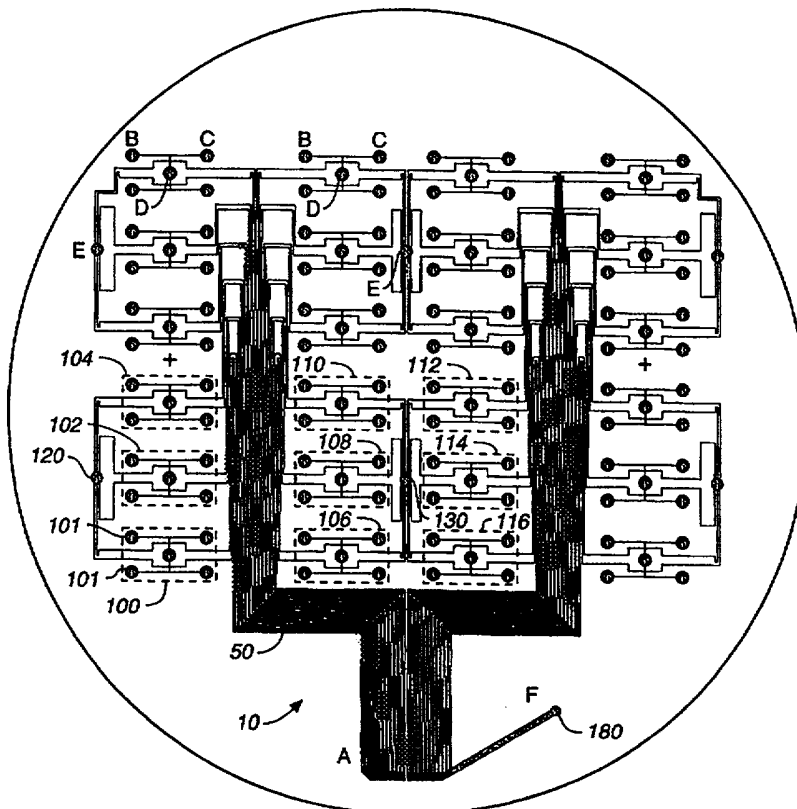

FOR THE PURPOSES OF INFORMATION ONLY

Codes used to identify States party to the PCT on the front pages of pamphlets publishing international applications under the PCT.

AL	Albania	ES	Spain	LS	Lesotho	SI	Slovenia
AM	Armenia	FI	Finland	LT	Lithuania	SK	Slovakia
AT	Austria	FR	France	LU	Luxembourg	SN	Senegal
AU	Australia	GA	Gabon	LV	Latvia	SZ	Swaziland
AZ	Azerbaijan	GB	United Kingdom	MC	Monaco	TD	Chad
BA	Bosnia and Herzegovina	GE	Georgia	MD	Republic of Moldova	TG	Togo
BB	Barbados	GH	Ghana	MG	Madagascar	TJ	Tajikistan
BE	Belgium	GN	Guinea	MK	The former Yugoslav Republic of Macedonia	TM	Turkmenistan
BF	Burkina Faso	GR	Greece	ML	Mali	TR	Turkey
BG	Bulgaria	HU	Hungary	MN	Mongolia	TT	Trinidad and Tobago
BJ	Benin	IE	Ireland	MR	Mauritania	UA	Ukraine
BR	Brazil	IL	Israel	MW	Malawi	UG	Uganda
BY	Belarus	IS	Iceland	MX	Mexico	US	United States of America
CA	Canada	IT	Italy	NE	Niger	UZ	Uzbekistan
CF	Central African Republic	JP	Japan	NL	Netherlands	VN	Viet Nam
CG	Congo	KE	Kenya	NO	Norway	YU	Yugoslavia
CH	Switzerland	KG	Kyrgyzstan	NZ	New Zealand	ZW	Zimbabwe
CI	Côte d'Ivoire	KP	Democratic People's Republic of Korea	PL	Poland		
CM	Cameroon	KR	Republic of Korea	PT	Portugal		
CN	China	KZ	Kazakstan	RO	Romania		
CU	Cuba	LC	Saint Lucia	RU	Russian Federation		
CZ	Czech Republic	LI	Liechtenstein	SD	Sudan		
DE	Germany	LK	Sri Lanka	SE	Sweden		
DK	Denmark	LR	Liberia	SG	Singapore		
EE	Estonia						

MICROFABRICATED CAPILLARY ARRAY ELECTROPHORESIS DEVICE AND METHOD

Statement as to Federally Sponsored Research

5 This invention was made with Government support under Grant No. DE-FG-91ER61125, awarded by the U.S. Department of Energy, and Grant No. HG01399, awarded by the National Institutes of Health. The Government has certain rights in the invention.

Background of the Invention

10 This invention relates to electrophoresis generally, and more particularly, to an apparatus and method for performing capillary array electrophoresis on microfabricated structures.

 In many diagnostic and gene identification procedures such as gene mapping, gene sequencing and disease diagnosis, deoxyribonucleic acid (DNA), ribonucleic acid (RNA) or proteins are separated according to their physical and chemical
15 properties. In addition to DNA, RNA or proteins, other small molecule analytes may also need to be separated.

 One electrochemical separation process is known as electrophoresis. In this process, molecules are transported in a capillary or a channel which is connected to a
20 buffer-filled reservoir. An electric field in the range of kilovolts is applied across both ends of the channel to cause the molecules to migrate. Samples are typically introduced at a high potential end and, under the influence of the electric field, move toward a low potential end of the channel. After migrating through the channel, the separated samples are detected by a suitable detector.

25 Typically, electrophoretic separation of nucleic acids and proteins is carried out in a gel separation medium. Although slab gels have played a major role in electrophoresis, difficulties exist in preparing uniform gels over a large area, in maintaining reproducibility of the different gels, in loading sample wells, in uniformly cooling the gels, in using large amounts of media, buffers, and samples, and in
30 requiring long run times for extended reading of nucleotides. Moreover, slab gels are not readily amenable to a high degree of multiplexing and automation. Recently,

micro-fabricated capillary electrophoresis (CE) devices have been used to separate fluorescent dyes and fluorescently labeled amino acids. Additionally, DNA restriction fragments, polymerase chain reaction (PCR) products, short oligonucleotides and even DNA sequencing fragments have been effectively separated with CE devices. Also, integrated micro-devices have been developed that can perform polymerase chain reaction amplification immediately followed by amplicon sizing, DNA restriction/digestion and subsequent size-based separation, and cells sorting and membrane lysis of selected cells. However, these micro-fabricated devices only perform analysis on one channel at a time. For applications such as population screening or DNA sequencing, such a single channel observation and analysis results in an unacceptable delay for screening many members of a population.

Summary of the Invention

The invention provides a capillary array electrophoresis (CAE) micro-plate. The micro-plate has an array of separation channels connected to an array of sample reservoirs on the plate. The sample reservoirs are organized into one or more sample injectors. A waste reservoir is provided to collect wastes from sample reservoirs in each of the sample injectors. Additionally, a cathode reservoir is multiplexed with one or more separation channels. An anode reservoir which is common to some or all separation channels is also provided on the micro-plate. Moreover, the distance from the anode to each of the cathodes is kept constant by deploying folded channels. The corners on these turns may be right angle turns or more preferably, smooth curves to improve electrophoretic resolution.

In one aspect, the reservoir layout on the substrate separates the sample reservoirs by a predetermined spacing to facilitate the simultaneous loading of multiple samples.

In another aspect, cathode, anode and injection waste reservoirs are combined to reduce the number of holes N in the substrate to about $5/4N$ where N is the number of samples analyzed.

In another aspect, the separation channels are formed from linear segments.

In another aspect, the separation channels are formed from curvilinear

segments, which may include radial segments.

In yet another aspect, the separation channels span from the perimeter of the plate to the central region of the plate. The separation channels may span the plate in a linear or a radial fashion.

5 In yet another aspect, a CAE micro-plate assembly is formed using a micro-plate, a reservoir array layer, and an electrode array. The assembly simplifies sample handling, electrode introduction and allows an increased volume of buffer to be present in the cathode and anode reservoirs.

Advantages of the invention include the following. The micro-plate of the present invention permits analysis of a large number of samples to be performed at once on a small device. Moreover, the micro-plate allows samples to be easily loaded while minimizing the risk of contamination. Additionally, the micro-plate is easy to electrically address. Further, the micro-plate supports a wide variety of formats that can provide higher resolution separation and detection of samples, faster separation and detection of samples, or separation and detection of more samples.

15

Other features and advantages will be apparent from the following description and the claims.

Brief Description of the Drawings

20

The accompanying drawings, which are incorporated in and constitute a part of the specification, schematically illustrate the present invention and, together with the general description given above and the detailed description given below, serve to explain the principles of the invention.

Fig. 1 is a capillary array electrophoresis (CAE) micro-plate layout.

25

Fig. 2 is a schematic illustration of the sample injector of Figure 1.

Figs. 3A-3D are illustrations of the operation of the sample injector of Figure

2.

Fig. 4A is an exploded perspective view of a CAE micro-plate assembly.

Fig. 4B is a cross-sectional side view of the CAE micro-plate assembly of Fig.

30

4A.

Fig. 5 is an illustration of a laser excited galvo-scanner in conjunction with a CAE micro-plate.

Figs. 6A and 6B are images of separations of genetic markers for hereditary hemochromatosis.

Fig. 7 is a plot of electropherograms generated from the images of Figs. 6A and 6B.

5 Fig. 8 is a second CAE micro-plate layout.

Fig. 9 is a third CAE micro-plate layout.

Fig. 10 is a schematic illustration of a sample injector of Figure 9.

Fig. 11 is an enlarged view of a perimeter portion of the CAE micro-plate layout of Figure 9.

10 Fig. 12 is an enlarged view of a center portion of the CAE micro-plate layout of Figure 9.

Description

Referring now to Figure 1, a capillary array electrophoresis (CAE) micro-plate
15 10 is shown. The micro-plate 10 has an array of capillaries or separation channels 50 etched thereon. In one embodiment of Figure 1, 48 individual separation channels are etched in a 150 micron (μm) periodic array. In this embodiment, the separation channels 50 branch out to an 8x12 array of sample reservoirs 101, each of which is spaced a predetermined distance apart to facilitate loading with an 8-tipped pipetter.
20 In this case, each sample reservoir 101 is spaced in one dimension nine millimeters apart from another sample reservoir. The separation channels 50 extend by a first predetermined distance from an injection region to an anode reservoir 180 and by a second predetermined distance from an injector group 100 to a cathode reservoir 120. The first predetermined distance may be about 10 centimeters, while the second
25 predetermined distance may be about 1.8 centimeters.

Each of the sample reservoirs 101 belongs to an injector group such as one of injector groups 100-116. Additionally, injector groups 100, 102 and 104 are connected to a cathode reservoir 120. Although the cathode reservoir 120 is connected to three sample injectors 100, 102 and 104, other cathode injectors may be
30 connected to more than three sample injectors. For instance, a cathode injector 130 is connected to sample injectors 106, 108, 110, 112, 114 and 116.

The anode reservoir 180 is placed in a non-symmetrical manner in this case to

avoid a conflict with a scanning system. Moreover, the distance for paths from the anode reservoir 180 to any one of cathodes 120 or 130 is identical for all separation channels. The equal distance is achieved by providing folded paths connecting certain sample reservoirs that are close to the anode 180 to increase the path length and to achieve a uniform distance between the anode reservoir 180 and the cathode reservoirs 120 and 130 for all sample reservoirs.

In the embodiment of Figure 1, the number of holes H in the micro-plate 10 is about $5N/4$, and more exactly, $5N/4+7$, where N is a number of samples. As the embodiment of Figure 1 addresses 96 samples in parallel, 127 holes are required to be drilled. This number of holes is close to a theoretical minimum number of holes of $N+3$. The reduction in hole counts is advantageous as fewer holes need to be drilled into the micro-plate 10, thereby increasing manufacturing efficiency as well as decreasing the potential for defects in the production of micro-plates, as caused by mechanical stress associated with the drilling process.

Another reason for multiplexing the cathode, anode and waste reservoirs is to make it more feasible to fit 96 separation system on a single substrate. The above advantages are also applicable in the event that the holes are formed by a molding process or a bonding process in lieu of the drilling process.

Turning now to Figure 2, details of the sample injector 100 of Figure 1 are shown. The sample injector 100 has a plurality of sample reservoirs 200, 204, 220 and 224. Sample reservoirs 200 and 220 contain a first sample, while sample reservoirs 204 and 224 contain a second sample.

The sample injector 100 also has a first separation channel 202 and a second separation channel 222. The sample injector 100 thus permits a serial analysis of two different samples on each separation channel. The first and second separation channels 202 and 222 are connected to a waste reservoir 208 by a cross channel 207. The sample injector 100 also has a cathode end 210 as well as an anode end 212. The cathode and anode ends 210 and 212 are at opposite ends of the first separation channel 202. Similarly, a second cathode end 214 is connected to a second anode end 216 by a separation channel 222 that is connected to the waste reservoir 208. As illustrated below, by a proper biasing of the anode reservoirs 211 and 212, cathode reservoirs 200 and 214, sample reservoirs 200, 204, 220, 224, and waste reservoir

208, samples may be moved from their respective sample reservoirs 200, 204, 220 and 224 through the cross channel to the waste reservoir thereby facilitating an insertion into the separation channel.

Referring now to Figures 3A, 3B, 3C and 3D, a process for loading a sample
5 from its respective sample reservoir into the cross channel and then performing a separation is shown. In Figure 3A, an injection voltage, preferably about 300 volts (3.0 V/cm), is applied between the sample reservoir 200 and the injection waste reservoir 208 to draw a sample through a channel that passes from the sample reservoir to the waste reservoir and crosses the separation channel.

10 In Figure 3B, a separation voltage of about 3700 volts (300 V/cm), for example, is applied between the cathode end 210 and the anode end 212. This causes the electrophoretic separation of the sample. In addition, a back-bias of the potential between the sample reservoir 200 and the injection waste reservoir 208 is applied.

15 Preferably, the back biasing voltage is about 720 volts. The back-biasing operation clears excess samples from the injection cross-channel 213. As illustrated in Figure 3B, a 100 μ m sample plug is injected and any residual sample is pulled away from the injection region to avoid tailing side-effects. Figures 3C and 3D represents analogous injections from the second sample reservoir 204. Although the embodiment of
20 Figures 2 and 3A-3D operates on two samples, four samples may be injected onto a single capillary without any significant cross-contamination.

The process of etching patterns into a representative micro-plate is discussed next. In one microfabricated embodiment, Borofloat glass wafers available from Schott Corporation of Yonkers, NY are pre-etched in 49% HF for 15 sec and cleaned before deposition of an amorphous silicon sacrificial layer of about 1500 \AA in a plasma
25 enhanced chemical vapor deposition (PECVD) system. The wafers are primed with hexamethyldisilazane, spin coated at 5000 rpm with a photoresist such as a 1818 photoresist available from Shipley Corp. of Marlborough, MA. The photoresist is developed in a 1:1 mixture of Microposit developer concentrate available from Shipley and water. The wafers are then soft-baked at 90 $^{\circ}$ C for 30 minutes. The
30 mask pattern is transferred to the substrate by exposing the photoresist to ultraviolet radiation in a Quintel contact mask aligner. The mask pattern is transferred to the amorphous silicon by a CF₄ plasma etch performed in the PECVD reactor. The

wafers are etched in a 49% HF solution for about 3 minutes at an etch rate of 7 $\mu\text{m}/\text{min}$ to form a final etch depth of 21 μm and channel width of $\sim 60 \mu\text{m}$ at the bonded surface. The photoresist is stripped and the remaining amorphous silicon is removed in a CF_4 plasma etch. Holes are drilled into the etched plate using a 1.25 mm diameter diamond-tipped drill bit, available from Crystalite Corporation of Westerville, OH. The etched and drilled plate is thermally bonded to a flat wafer of similar size and type in a programmable vacuum furnace. After bonding, the channel surfaces are coated using a coating protocol.

Turning now to Figures 4A and 4B, an exploded view and a cross-sectional side view of a CAE micro plate are shown. In Figure 4A, a CAE micro-plate 302 with etched separation channels 301 and a plurality of reservoirs 303 formed thereon is provided. A reservoir array layer 304 is mounted above the CAE micro-plate 302 to provide additional reservoir space above the reservoirs formed on the micro-plate 302. The presence of the reservoir array layer 304 increases the volume of buffers in the cathode and anode reservoirs and simplifies sample handling and electrode introduction. Preferably, the reservoir array layer 304 is a one millimeter thick elastomer sheet which makes a watertight seal when it is in contact with the glass micro-plate 302. The reservoir array layer 304 may be an elastomer such as Sylgard 184, available from Dow Corning of Midland, Michigan.

The reservoir array layer 304 is placed onto the micro-plate 302 before the channels are filled with a separation medium. Preferably, the separation medium is 0.75 percent weight/volume hydroxyethylcellulose (HEC) in a 1X TBE buffer with $1 \mu\text{M}$ ethidium bromide. Additionally, the reservoir array 304 fully isolates the reservoirs from each other. The separation channels are pressure filled with a sieving matrix from the anode reservoir 180 until all channels have been filled. The anode and cathode reservoirs 180 and 120 are then filled with a 10X TBE buffer to reduce ion depletion during electrophoresis. The sample reservoirs are rinsed with deionized water. Samples are then loaded from a micro-titer plate using an 8-tipped pipetter.

After the reservoir array layer 304 is positioned on the micro-plate 302, an electrode array 306 is placed above the reservoir array 304. The electrode array 306 is fabricated by placing an array of conductors such as platinum wires through a printed circuit board. Each conductor is adapted to engage a reservoir on the micro-

plate 302. Moreover, the wires are electrically connected with metal strips on the circuit board to allow individual reservoirs of a common type to be electrically addressed in parallel. The electrode array 306 also reduces the possibility of buffer evaporation. The electrode array 306 in turn is connected to one or more computer
5 controlled power supplies.

As shown in Figure 4B, the reservoir array layer 304, when used in conjunction with the micro-plate 302, enlarges the effective volume of the reservoirs originally formed on the micro-plate 302. Moreover, electrodes from the electrode array 306 are adapted to probe the reservoirs on the micro-plate 302 and the reservoir
10 array layer 306. The solutions are placed in the reservoirs by a pipetter 308.

After assembly, the CAE micro-plate 302 is probed with a galvo-scanner system 400, as shown in Figure 5. The system 400 measures fluorescence using a detector at a detection zone of the channels. During the process of electrophoresis, as a fluorescent species traverses a detection zone, it is excited by an incident laser
15 beam. In a direct fluorescence detection system, either the target species is fluorescent, or it is transformed into a fluorescent species by tagging it with a fluorophore. The passing of the fluorescent species across the detection zone results in a change, typically an increase in fluorescence that is detectable by the system 400.

Turning now to the analysis system, the galvo-scanner 400 has a frequency-
20 doubled YAG laser such as YAG laser available from Uniphase Corporation of San Jose, California. The YAG laser generates a beam which may be a 30 mW, 532 nm beam. The beam generated by the laser 402 travels through an excitation filter 404 and is redirected by a mirror 406. From the mirror 406, the beam travels through a beam expander 408. After expansion, the beam is directed to a dichroic beam splitter
25 410. The laser beam is directed to a galvanometer 420 which directs the beam to a final lens assembly 422. In this manner, the beam is focused on a spot of about 5 μm where it excited fluorescence from the molecules in the channels and is scanned across the channels at 40 Hz. The resulting fluorescence is gathered by the final lens and passed through the galvomirror and the dichroic beam splitter 410 to an emission
30 filter 412 which operates in the range of about 545-620 nm. After passing through the emission filter 412, the beam is focused by a lens 414. Next, the beam is directed through a pinhole 416 such as a 400 μm pinhole for delivery to a photomultiplier

(PMT) 418.

The electrode array 306 is connected to one or more power supplies 428 such as a series PS300, available from Stanford Research Systems of Sunnyvale, California. The power supplies are connected to a computer and software controlled to automatically time and switch the appropriate voltages into the electrode array 306. The software may be written in a conventional computer language, or may be specified in a data acquisition software such as LabVIEW, available from National Instruments of Austin, Texas. Data corresponding to spatially distinct fluorescent emission may then be acquired at about 77 kHz using a 16 bit A/D converter from Burr-Brown Corporation of Tucson, Arizona. Logarithmic data compression is then applied to generate five linear orders of dynamic measurement range. The data is obtained as a 16 bit image, and electropherograms are then generated using a suitable software such as IPLab, available from Signal Analytics, Vienna, Virginia, to sum data points across each channel. A detection of all lanes with a 0.09 second temporal resolution has been achieved by the system 400.

EXPERIMENTS

An electrophoretic separation and fluorescence detection of HFE, a marker gene for hereditary hemochromatosis, was performed to demonstrate the high-throughput analysis of biologically relevant samples using the CAE micro-plates of the present invention. HFE is a genetic disorder that causes a buildup of iron in tissues resulting over time in disease. The buildup primarily affects the liver. Between 0.1 and 0.5% of the Caucasian population are homozygous for an HFE C282Y variant responsible for this disease. If detected early, treatment can be initiated and long term effects avoided. To screen the population for this marker gene, a high throughput screening system is needed.

In this experiment, samples were prepared using PCR amplification and digestion to assay the C282Y mutation in the HFE gene. This G A mutation at nucleotide 845 creates a *Rsa* I restriction site in the HFE gene. DNA materials were isolated from peripheral blood leukocytes using standard methods. A segment of an HFE exon containing the variant site was amplified with the following primers:

HH-E4B: 5'GACCTCTTCAGTGACCACTC3'

HC282R: 5'CTCAGGCACTCCTCTCAACC3'

The HC282R primer is a primer discussed in Feder et al., Nature Genet. 13, 399-408 (1996), hereby incorporated by reference. The HH-E4B primer contains a 5' biotin tag. The 25 μ l amplification reaction contained 10 mM Tris-HCl (pH = 8.8),
5 50 mM KCl, 0.75 mM MgCl₂, 0.2 mM dNTPs, 7.5 pM of each primer and 1.5 U AmpliTaq DNA, available from Perkin Elmer, Branchburg, NJ. The PCR was carried out under three consecutive conditions: 5 cycles (95° C for 1 min, 64° C for 1 min, 72° C for 1 min), 5 cycles (95° C for 1 min, 60° C for 1 min, 72° C for 1 min), and 25 cycles (95° C for 1 min, 56° C for 1 min, 72° C for 1 min). The restriction
10 digestion of amplified product was carried out by adding 4 μ l of each amplified sample to 6 μ l buffer containing 2 U *Rsa* I (Sigma, St. Louis, MO) and digesting for 90 minutes at 37° C. Samples were dialyzed against DI water on a 96 sample dialysis plate, available from Millipore, Bedford, MA. Sample types were initially established by separation of restriction fragments on 1% Agarose-3% SeaPlaque gel, available
15 from FMC Bioproducts, Rockland, ME, in 0.5x TBE. Gels were stained in 0.5 μ g/ml ethidium bromide for 30 minutes and visualized on a UV transilluminator, a Spectroline model TR-302, using a 123-bp ladder, available from Life Technologies Inc., Gaithersburg, MD, to determine fragment sizes.

Figure 6A and 6B present images of separations of 96 HFE samples on a CAE
20 micro-plate. The 96 samples were separated in two runs of 48 samples, corresponding to two injection reservoirs per channel. In this experiment, nineteen different samples were dispersed among the 96 sample wells, giving a 5-fold redundancy in sample analysis. An original image 500 was obtained for the first injection, while an original image 504 was obtained for the second injection.
25 Additionally, expanded images 502 and 506, corresponding to original images 500 and 504 are shown. The width of the electrophoretic image shown is 7.4 mm for 48 lanes and the complete analysis of 96 samples was performed in under 8 minutes. The expanded images show that the bands are of high intensity and resolution. The image exhibits a smile with the right lanes about 20 seconds faster than the left. This
30 is caused by a gradient in the electrophoresis voltages caused by the placement of the anode to the side of the injection region to ensure adequate clearance from the scanning lens.

Figure 7 presents the 96 electropherograms obtained from the images in Figures 6A and 6B. All electropherograms have been shifted to align a 167-bp doublet in order to compare the separations. The 167-bp fragment appears as a doublet due to a partial biotinylation of the HH-E4B primer, as the biotinylated form accounts for the slower migrating fragment in the doublet. The 167-bp doublet provides a useful reference point for the alignment of electropherograms to compare separations and allows an accurate genotyping without requiring a sizing ladder. As shown in Figure 7, an average distance between the 111 and 140-bp bands is 7.3 seconds with a standard deviation (SD) of 0.8 second and 0.6 second, respectively, for the first injection and 6.6 sec with a SD of 1.1 second and 0.5 second, respectively, for the second injection. Using a t-test, the typings for both injections are determined to be at about a 99.9% confidence level.

Referring to Figure 8, a second embodiment of the CAE micro-plate 600 is shown. In Figure 8, the micro-plate 600 is an array of injectors, each of which includes waste reservoirs 602 and 608, sample reservoirs 604, 606, 610 and 612. Each injector unit is connected to one of two cathode reservoirs 614 or 616, respectively. Additionally, each injector unit is connected to one capillary in an array of capillaries or channels 620. The capillaries or channels 620 are connected to an anode 630. In this design, 96 samples can be analyzed by injecting four samples serially on a single capillary. Further, 24 separation capillaries or channels are used to analyze the material in 96 sample reservoirs. Moreover, each of the injector units has two waste reservoirs. In total, the embodiment of Figure 8 has a hole count of $3N/2 + 3$.

Referring now to Figure 9, a third embodiment of the CAE micro-plate 650 is disclosed. In the CAE micro-plate 650 of Figure 9, cathode reservoirs 652 are positioned on a perimeter of the CAE micro-plate 650. Additionally, an anode reservoir 660 is positioned in the center of the CAE micro-plate 650. Separation channels or capillaries may emanate from an outer perimeter of the micro-plate 650 toward the center of the micro-plate 650 in a spiral pattern if longer separation channels are desired. Alternatively, if short paths are desired, the separation channels or capillaries may simply be a straight line connecting the perimeter of the micro-plate 650 to the center 660 of the CAE micro-plate 650.

Turning now to Figures 10 and 11, an injector unit of the CAE micro-plate of Figure 9 and its position on a perimeter of the micro-plate of Figure 9 are illustrated in detail. In Figure 10, two separation channels or capillaries 670 and 671 are connected to a common waste reservoir 672 and a common cathode reservoir 674. Additionally, the separation channels 670 and 671 are connected to sample reservoirs 676 and 678. As shown in Figures 10 and 11, the connections between the sample and waste reservoirs may intersect in an off-set manner.

Referring now to Figure 12, the common anode 660 of Figure 9 is illustrated in detail. As shown in Figure 11, a plurality of separation channels or capillaries 800-810 form a curvilinear pattern, which may be a radial pattern, converging on a central region 820. From the central region 820, the separation channels or capillaries form a passageway from the perimeter of the central region 820 to the common anode reservoir 660 at the center of the CAE micro-plate. The center area 820 is the area where a rotating scanner may be used for detection purposes.

Samples may be loaded manually or automatically. Serial injections may be used to increase the sample throughput with a predetermined number of capillaries. Moreover, while one embodiment of the present invention injects two samples per channel, an injection of four samples per channel may be used to analyze 192 samples per plate. Further, an increase in the number of capillaries on the CAE micro-plate would increase the throughput correspondingly without introducing any sample contamination. Moreover, the plate may be made of glass or plastic.

In addition, the scanning detection system may be altered by inverting its objective lens and scanning from below. Placing of the optics below the plate would permit facile manipulation and introduction of samples. The inverted scanning would also avoid spatial conflict with the anode reservoir, thereby permitting a central placement of the anode. Moreover, an array of PCR reaction chambers may be used with the micro-plate of the invention to allow for integrated amplification of low volume samples, eliminate sample handling and manual transfer, and reduce cost. Furthermore, the present invention contemplates that electronic heaters, thermocouples and detection systems may be used with an array of microfluidic capillaries to enhance the CAE electrophoresis process.

While the invention has been shown and described with reference to an

embodiment thereof, those skilled in the art will understand that the above and other changes in form and detail may be made without departing from the spirit and scope of the following claims.

WHAT IS CLAIMED IS:

1. A capillary array electrophoresis plate, comprising:
an array of separation channels formed on said plate; and
5 an array of sample reservoirs formed on said plate and coupled to said
separation channels.
2. The plate of claim 1, wherein said array of sample reservoirs are
organized into one or more sample injectors.
- 10 3. The plate of claim 2, further comprising a waste reservoir positioned in
each sample injector.
4. The plate of claim 3, wherein one of said waste reservoirs is coupled to
15 one or more sample reservoirs in each sample injector.
5. The plate of claim 1, further comprising a cathode reservoir, said
cathode reservoir being connected to one or more separation channels.
- 20 6. The plate of claim 1, further comprising an anode reservoir common to
one or more separation channels.
7. The plate of claim 1, wherein the plate has one set of reservoirs
positioned near an outer perimeter, and one set of reservoirs positioned near a center
25 and the separation channels connect the reservoirs near the outer perimeter to
reservoirs near the center.
8. The plate of claim 7, wherein the separation channels radially connect
the outer perimeter to the center.
- 30 9. The plate of claim 1, further comprising an electrode array coupleable
to said reservoir array.

10. The plate of claim 9, further comprising a reservoir array layer having an array of openings coupleable to said reservoir array.

5 11. The plate of claim 1, wherein said reservoir array is regularly spaced in one or two dimensions on said plate and adapted to engage a multi-headed pipetter.

12. A capillary array electrophoresis plate, comprising: a plurality of separation channels formed at a surface of said plate;
one or more anode reservoirs formed at a surface of said plate; and
10 one or more injectors formed at a surface of said plate, said injector having:
a plurality of sample reservoirs formed on said plate and coupled to said separation channels;
a plurality of waste reservoirs formed on said plate and coupled to said separation channels; and
15 at least one cathode reservoir multiplexed with a plurality of said separation channels.

13. The plate of claim 12, further comprising an electrode array coupleable to said reservoirs.

20

14. The plate of claim 12, wherein the plate has an outer perimeter and a center and the separation channels connect the outer perimeter to the center.

15. A capillary array electrophoresis plate comprising:
25 an array of microfabricated separation channels formed at a surface of a first microfabricated substrate and a corresponding surface of a second substrate bonded to said first and second substrates, each of said channels having first and second ends;
an array of sample reservoirs formed at a surface of said plate;
an array of waste reservoirs formed at a surface of said plate;
30 an array of cathode reservoirs coupled to the first end of each of the separation channels;
an array of anode reservoirs coupled to the second end of each of the

separation channels; and

an injector formed by an injection channel connected to one or more sample reservoirs that crosses a separation channel and connects to a waste reservoir.

5 16. The capillary array electrophoresis plate of claim 15, wherein both substrates are microfabricated.

 17. The capillary array electrophoresis plate of claim 15, wherein the substrates are made of glass.

10

 18. The capillary array electrophoresis plate of claim 15, wherein the substrates are made of plastic.

 19. The capillary array electrophoresis plate of claim 15, wherein one or
15 more separation channels are connected to a common cathode reservoir.

 20. The capillary array electrophoresis plate of claim 15, wherein one or more separation channels are connected to a common waste reservoir.

20 21. The capillary array electrophoresis plate of claim 15, wherein one or more separation channels are connected to a common anode reservoir.

 22. The capillary array electrophoresis plate of claim 15, wherein one or more sample reservoirs are connected to one separation channel and one or more
25 waste reservoirs.

 23. The capillary array electrophoresis plate of claim 15, further comprising a reservoir array layer mounted above the plate, the reservoir array layer having openings positioned to couple to the sample reservoirs, the waste reservoirs,
30 the cathode reservoirs, and the anode reservoirs.

 24. The plate of claim 15, further comprising an electrode array coupleable

to said reservoir array layer.

25. The capillary array electrophoresis plate of claim 15, wherein the first substrate has an array of electrodes aligned with the sample reservoirs, the waste
5 reservoirs, the cathode reservoirs, and the anode reservoirs to make electrical contacts with the solutions in the reservoirs.

26. The capillary array electrophoresis plate of claim 24 wherein said electrode array is integral with the two substrates.

10

27. The capillary array electrophoresis plate of claim 26, wherein the sample reservoirs are regularly spaced on the plate to receive solutions from a multi-headed pipetter system.

15 28. The capillary array electrophoresis plate of claim 15, wherein the plate has H holes, and wherein H is approximately equal to $5N/4$, with N being the number of samples to be processed.

20 29. The capillary array electrophoresis plate of claim 15, wherein the distance from each cathode reservoir to a corresponding injector is approximately equal and where the distance from each injector to its corresponding anode reservoir for each separation channel is approximately equal.

25 30. The capillary array electrophoresis plate of claim 15, wherein the plate is made of glass or plastic.

31. A method of forming a capillary array electrophoresis plate,
comprising:
forming an array of microfabricated separation channels at a surface of the
30 plate;
forming an array of microfabricated sample reservoirs at a surface of the plate;
and

connecting the array of microfabricated sample reservoirs to the array of microfabricated separation channels.

5 32. The method of claim 31, further comprising grouping the array of sample reservoirs into one or more injectors.

 33. The method of claim 32, further comprising forming a waste reservoir in each sample injector.

10 34. The method of claim 33, further comprising multiplexing a cathode reservoir with the sample reservoirs.

 35. The method of claim 34, further comprising multiplexing an anode reservoir to all sample reservoirs on the plate, wherein a distance from each cathode reservoir to a corresponding injector is approximately equal and where the distance from each injector to its corresponding anode reservoir for each separation channel is approximately equal.

 36. A method for injecting a sample through a capillary array electrophoresis plate with microfabricated separation channels connected to sample reservoirs, waste reservoirs, cathode reservoirs, and anode reservoirs, the method comprising:

 applying an injection voltage between a first reservoir and a waste reservoir to draw the sample into a cross channel region while applying a bias voltage to the cathode and anode reservoirs to control injection plug width;

 applying a running voltage between the cathode and anode reservoirs; and
 applying a biasing voltage to the waste and injector reservoirs to pull away residuals of the sample.

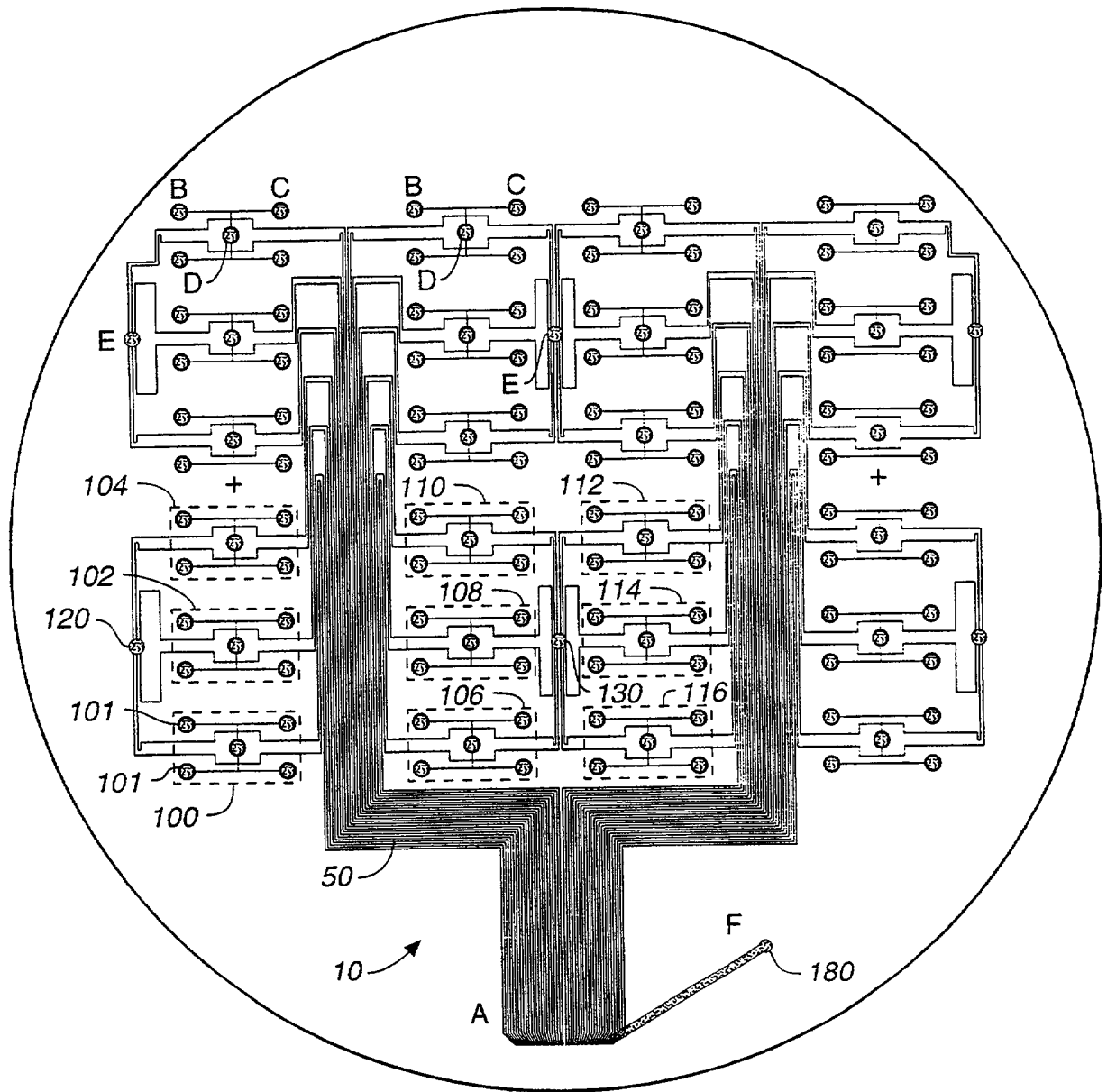
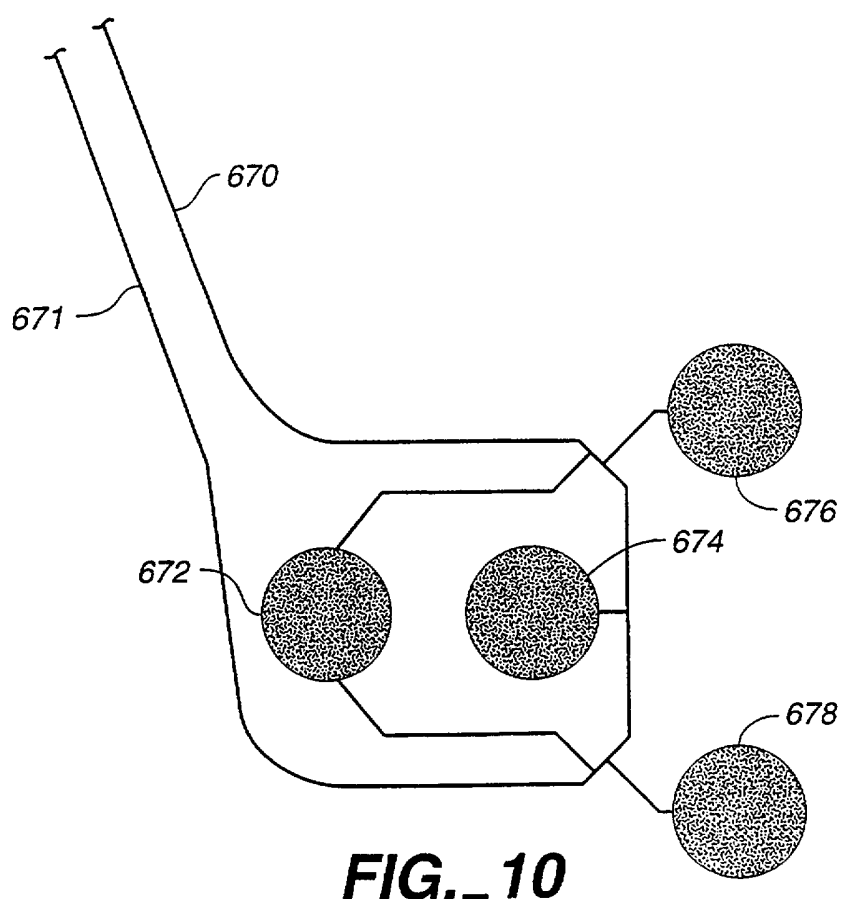
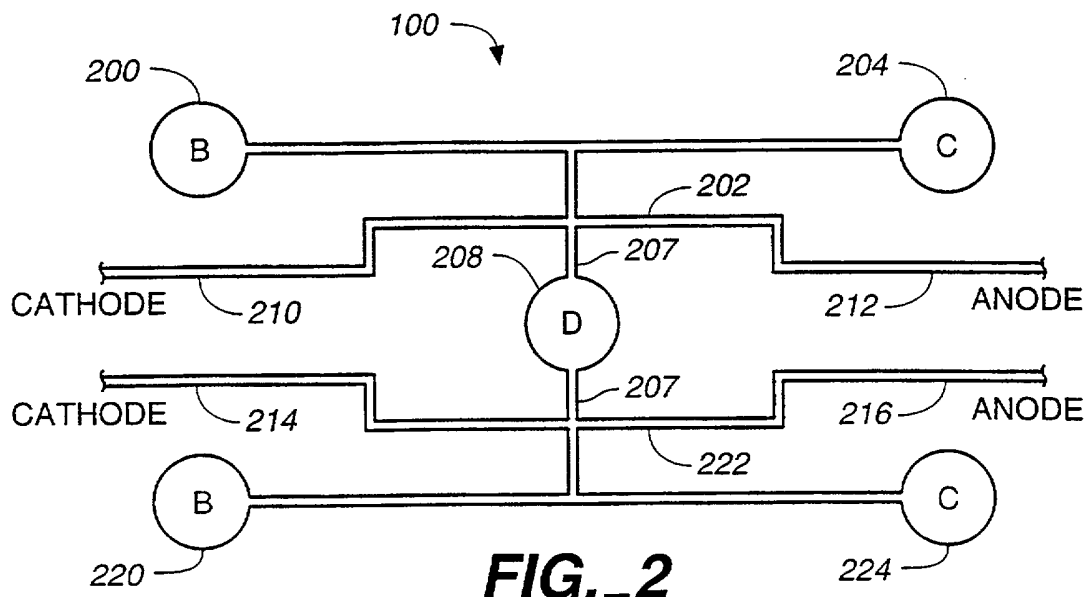

FIG. 1



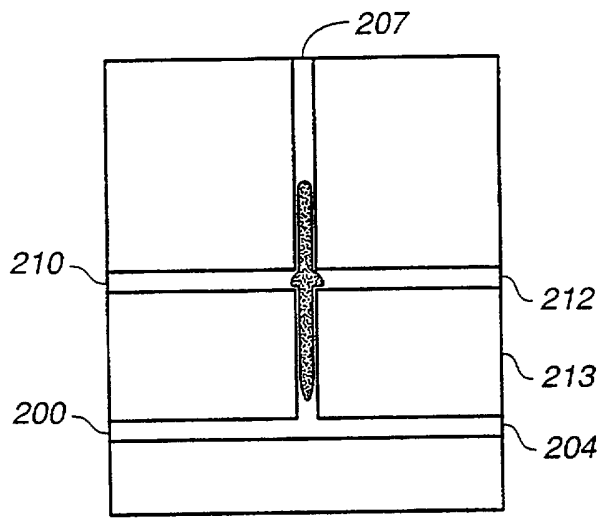

FIG._3A

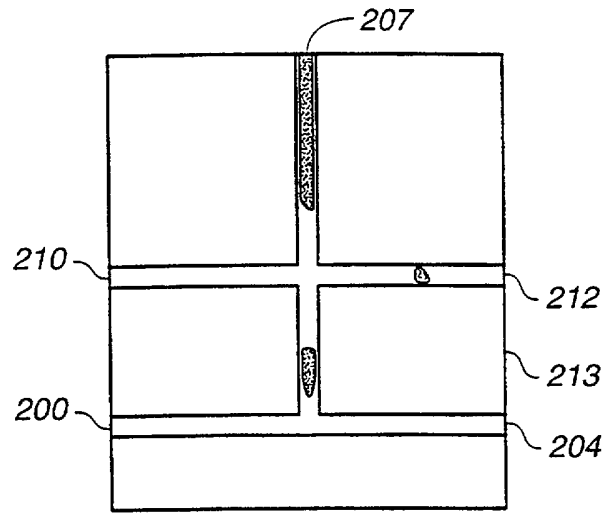

FIG._3B

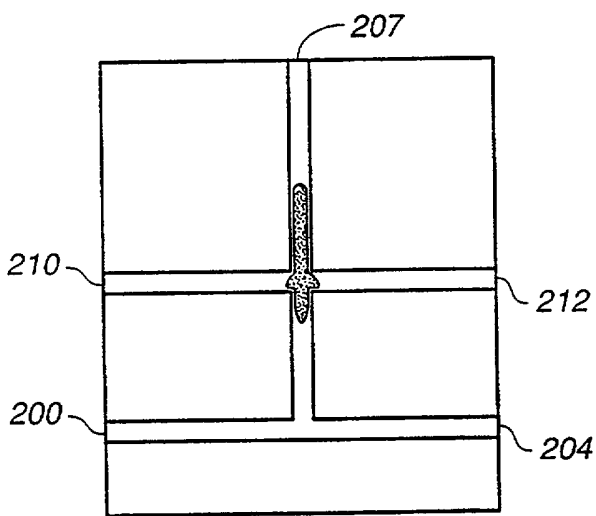

FIG._3C

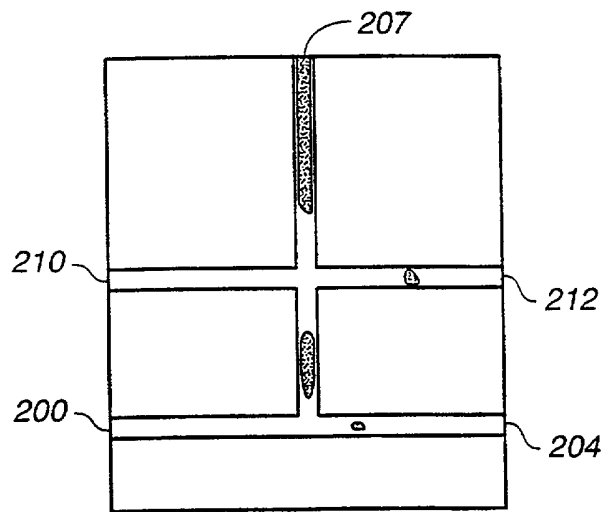

FIG._3D

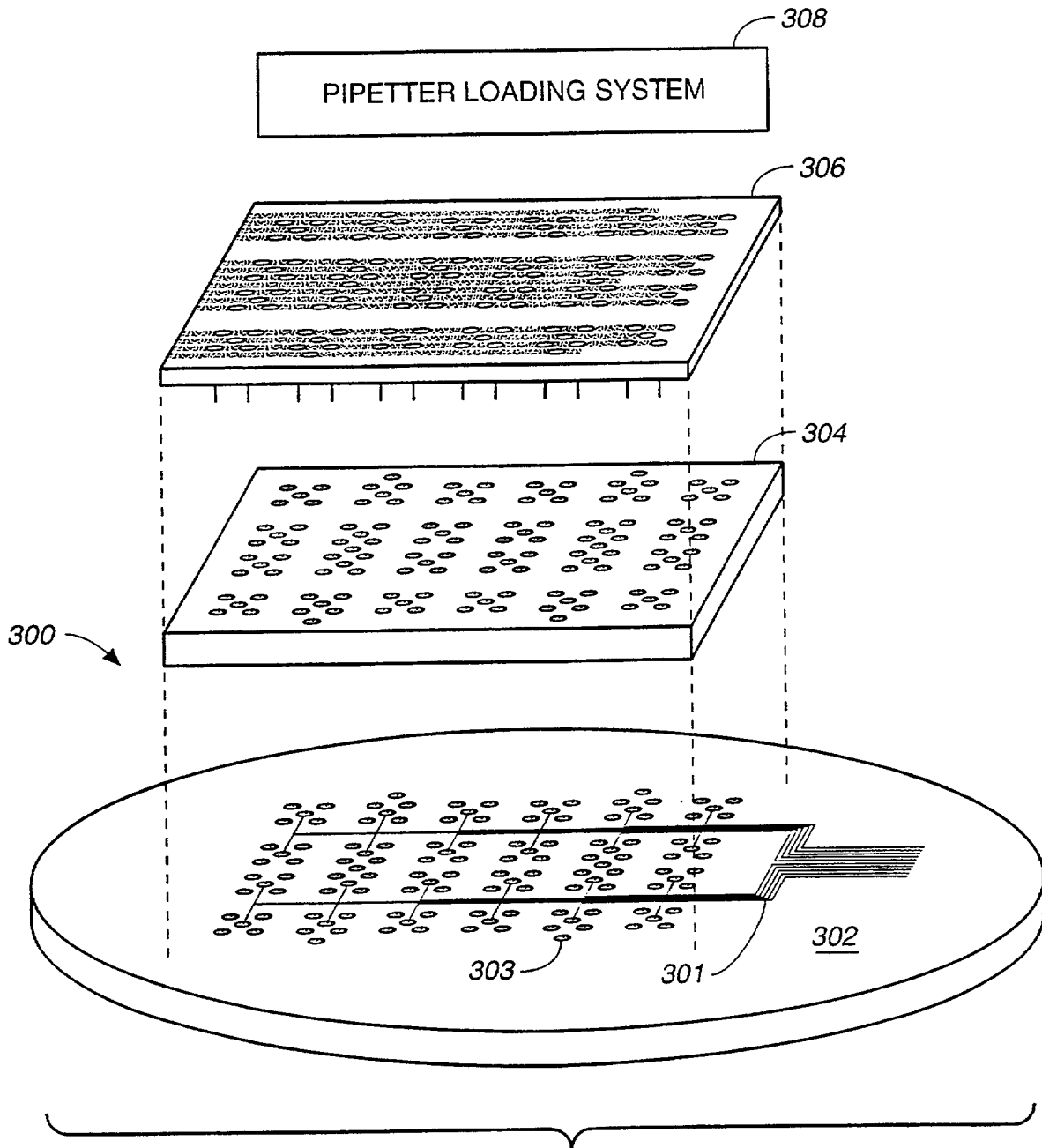

FIG. 4A

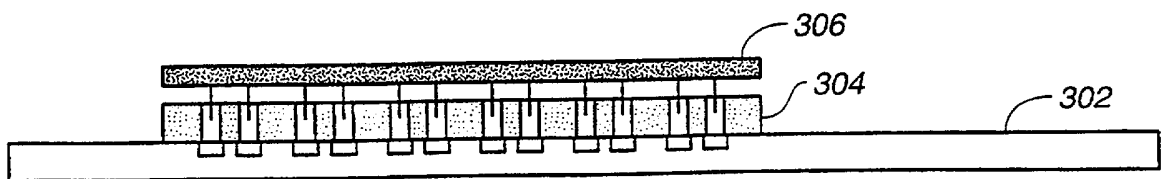

FIG. 4B

5/11

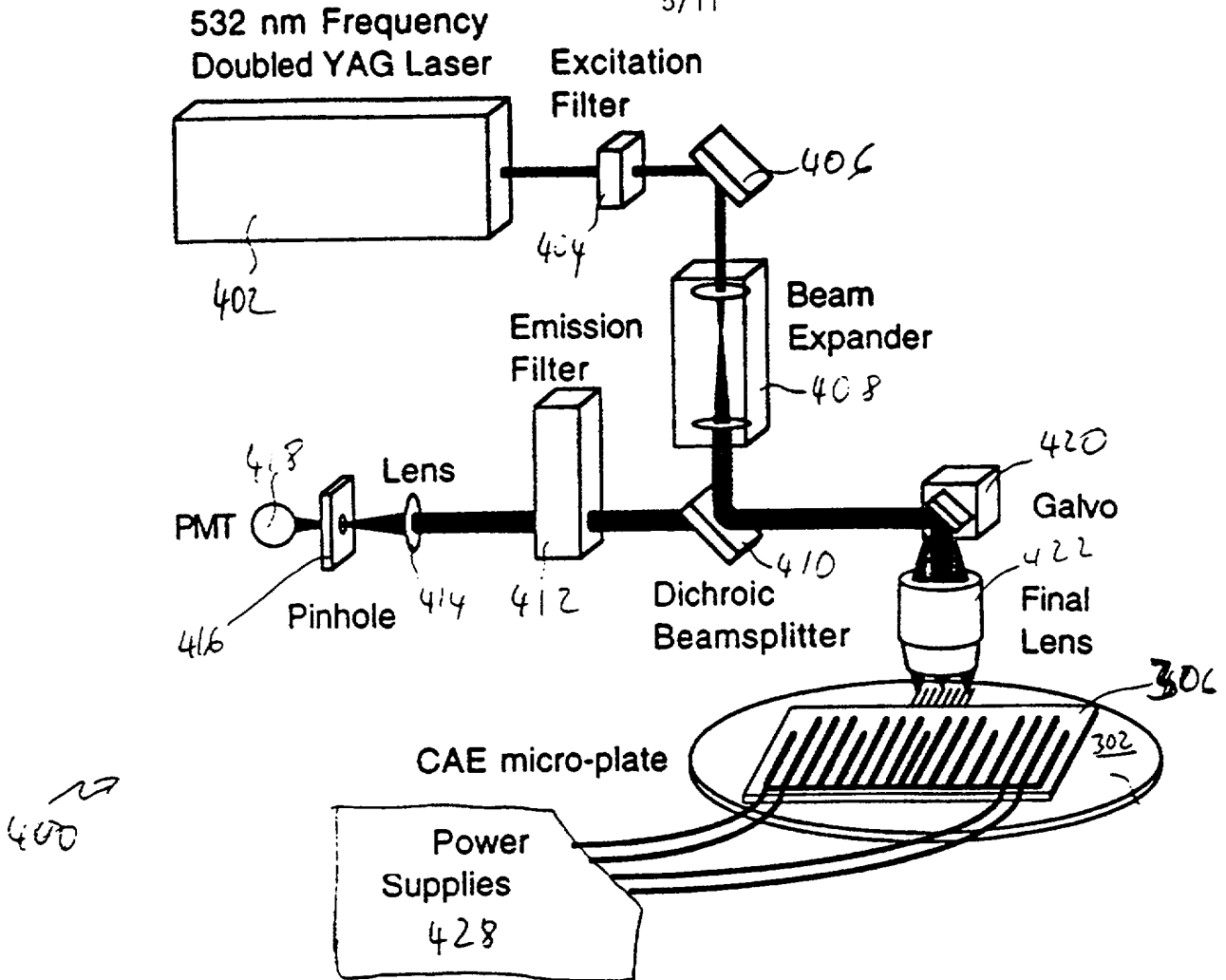
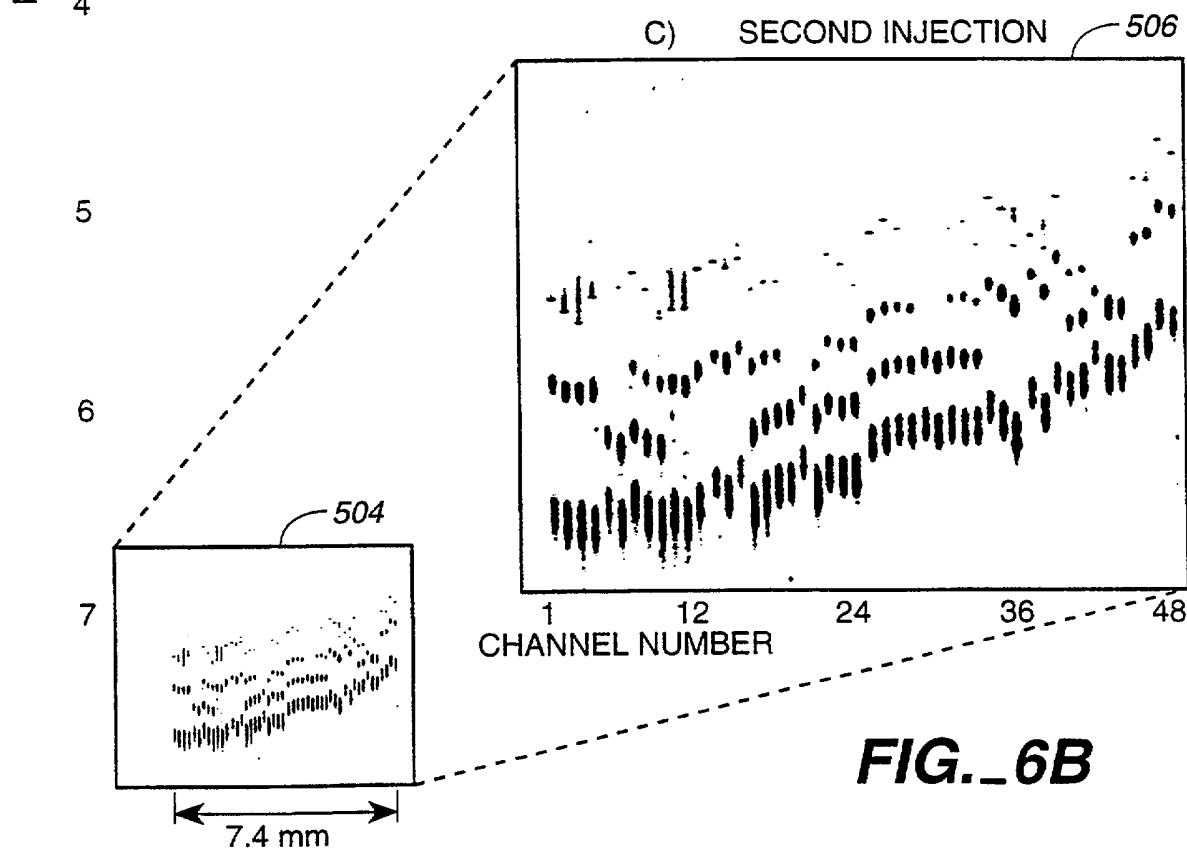
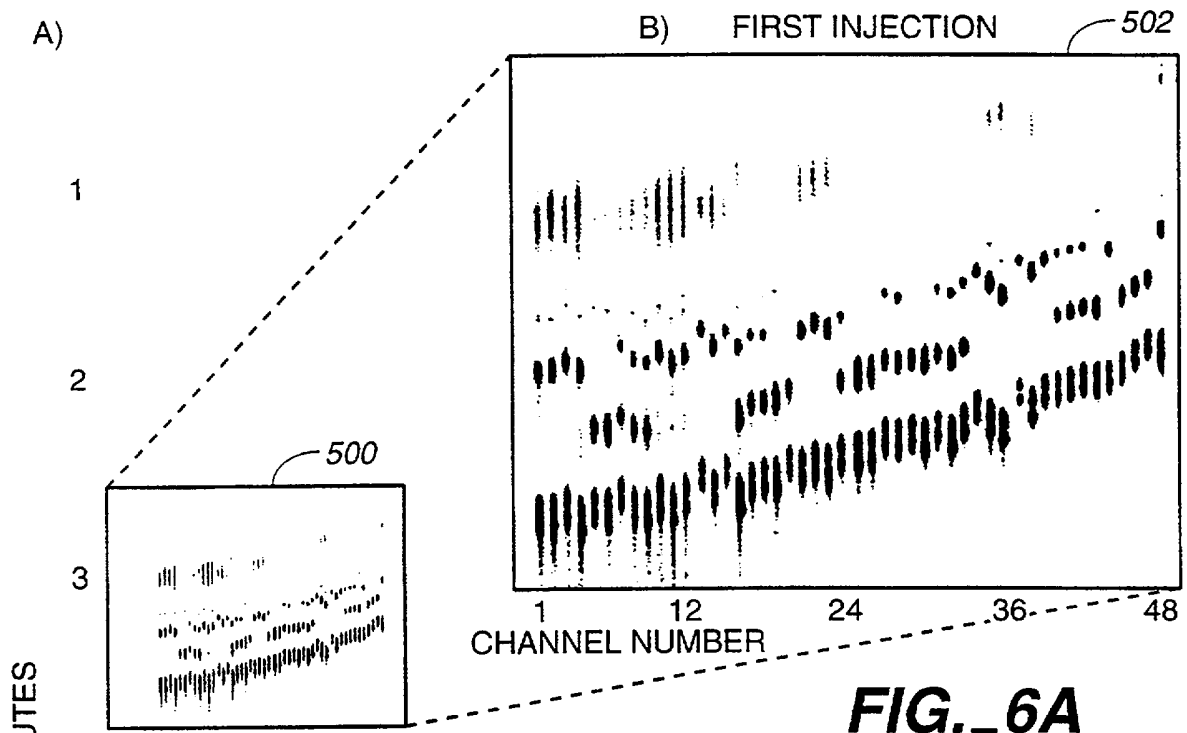

FIG. 5



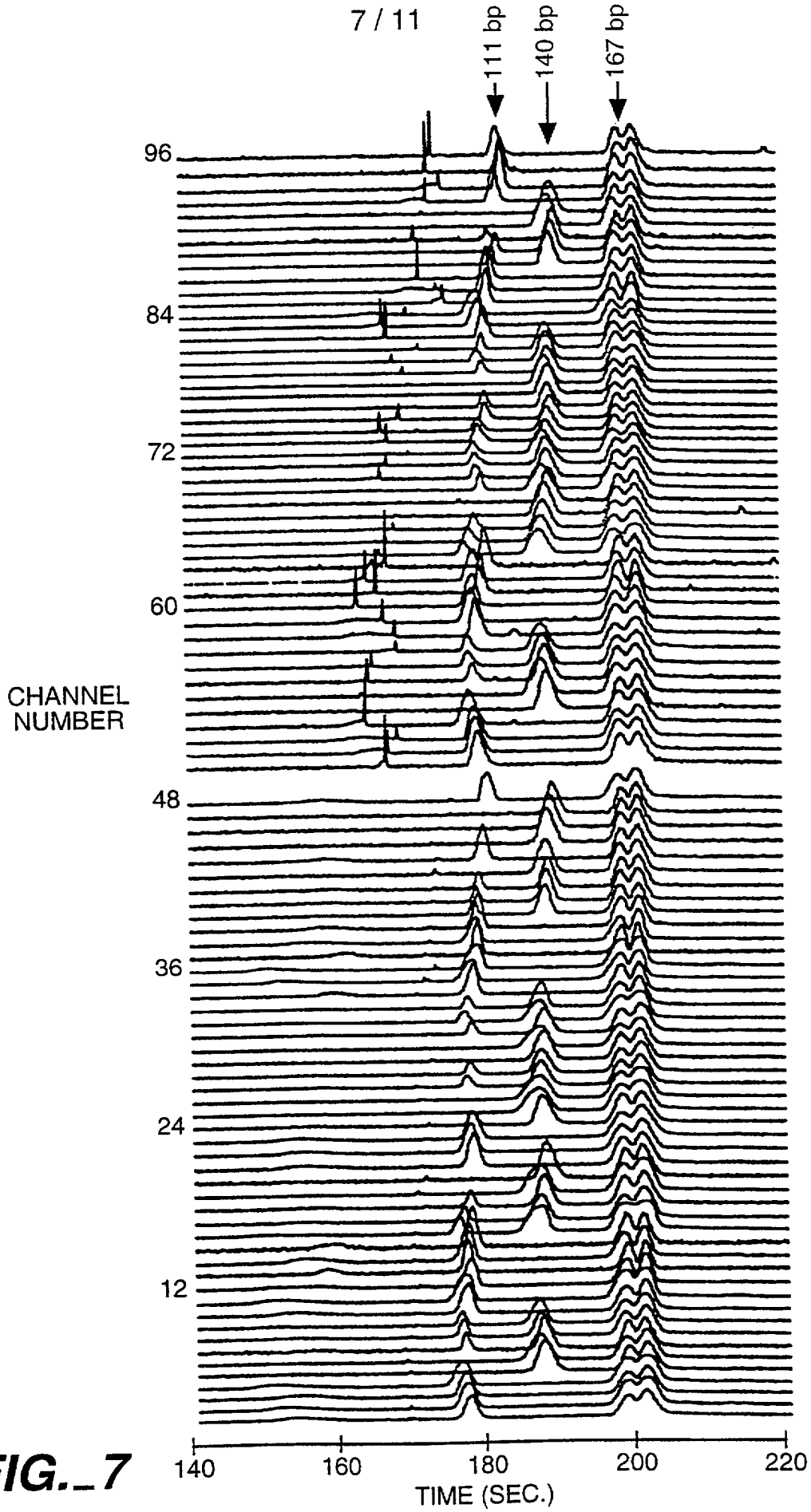

FIG. 7

SUBSTITUTE SHEET (RULE 26)

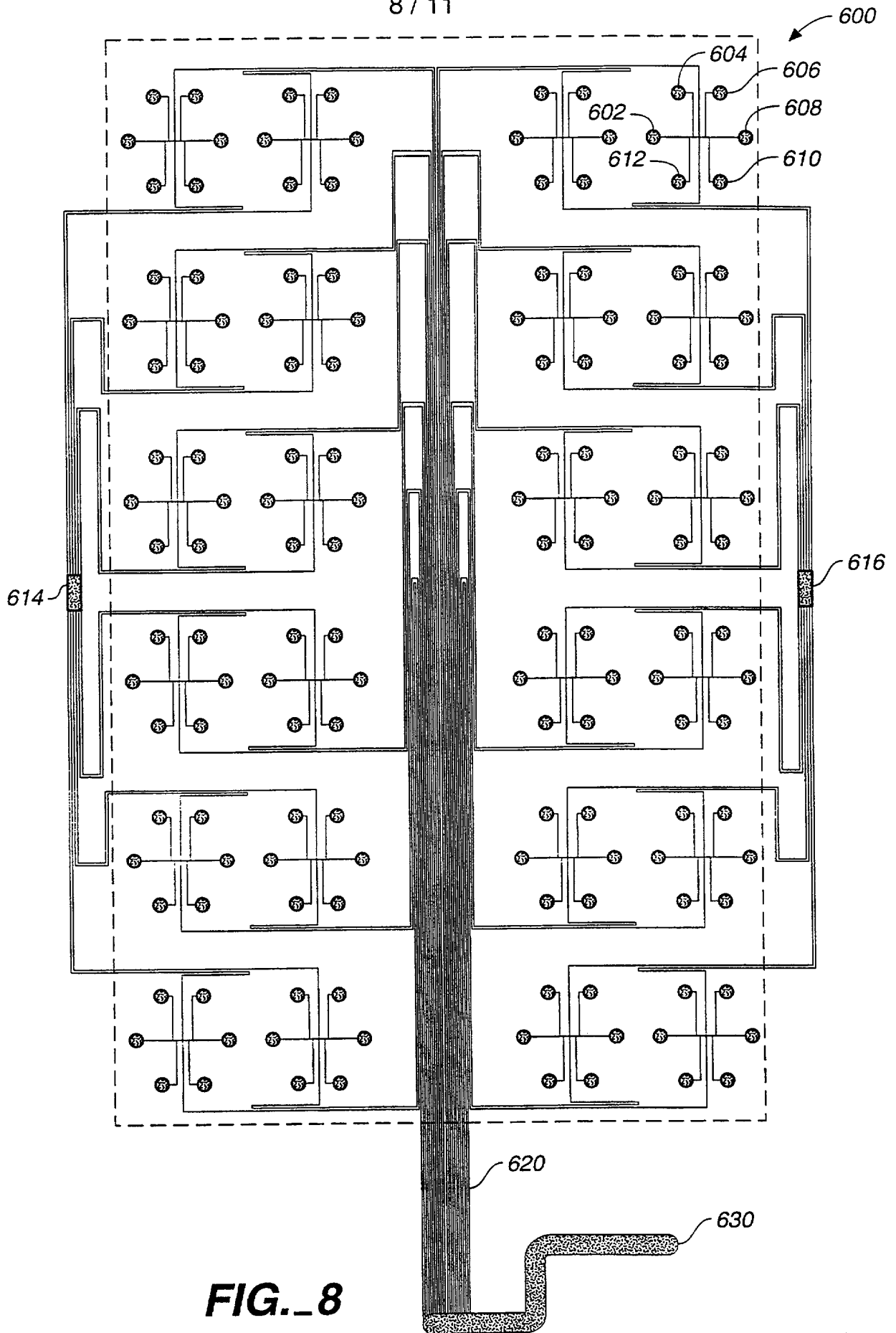

FIG. 8

SUBSTITUTE SHEET (RULE 26)

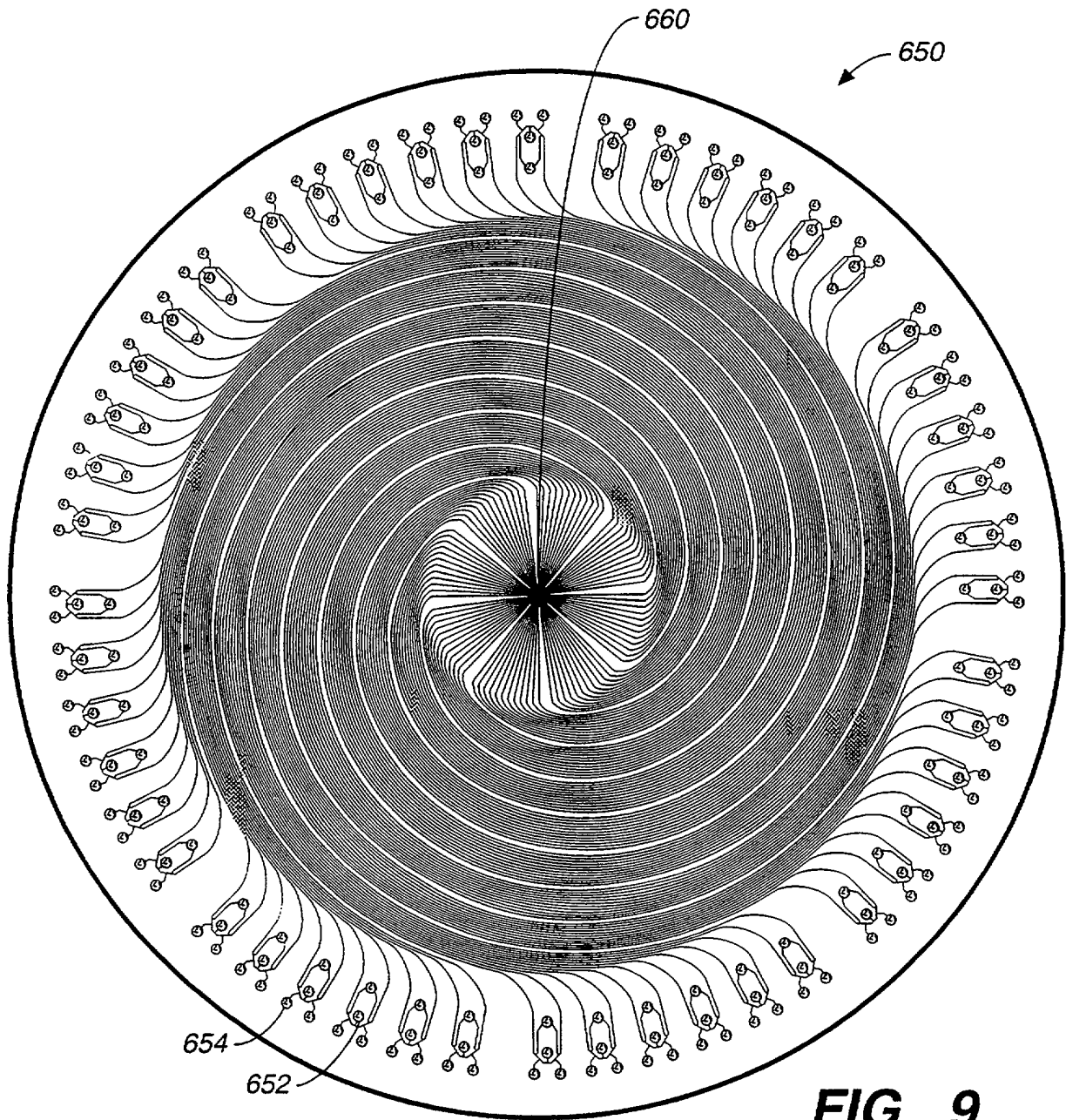

FIG. 9

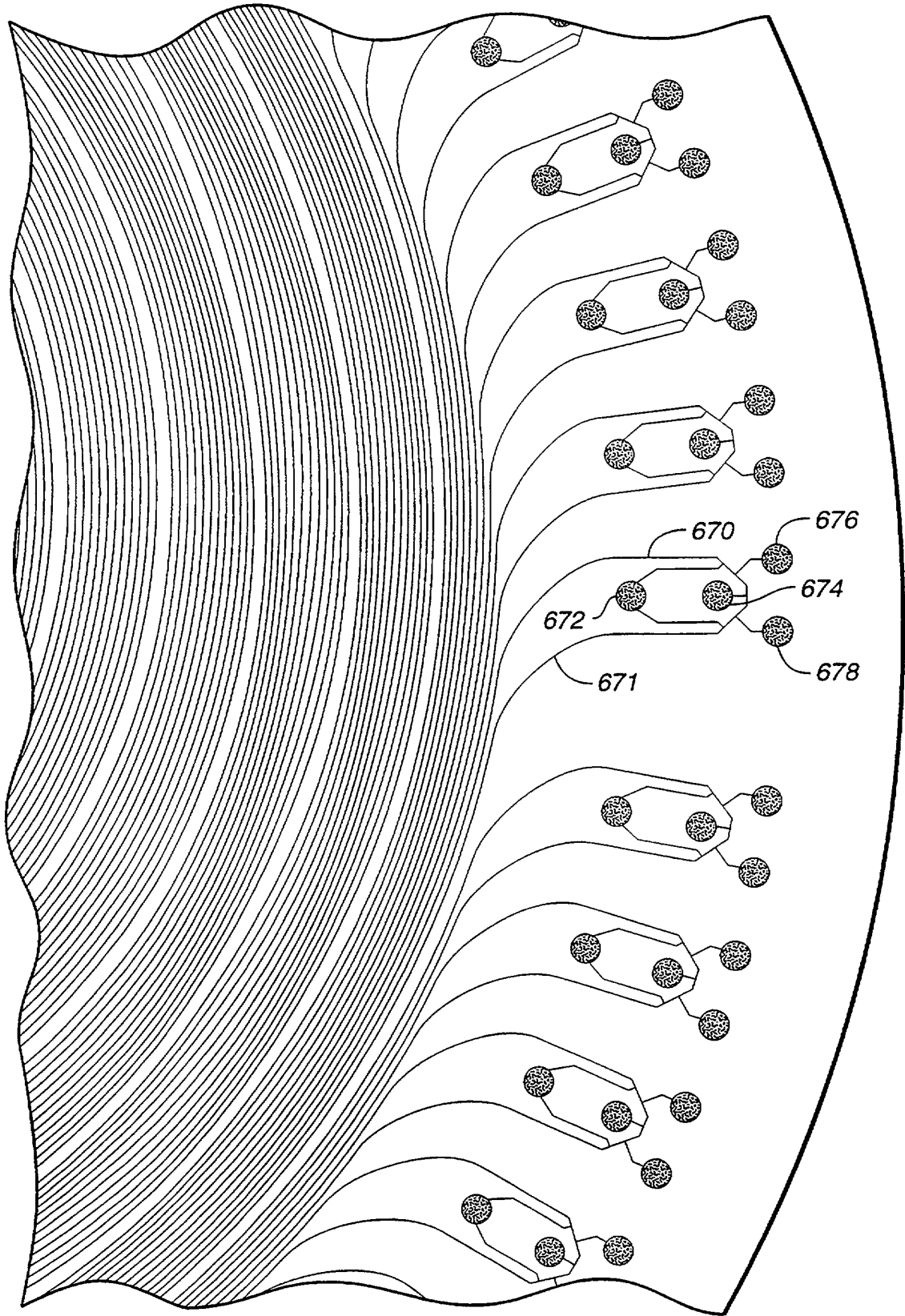

FIG. 11

SUBSTITUTE SHEET (RULE 26)

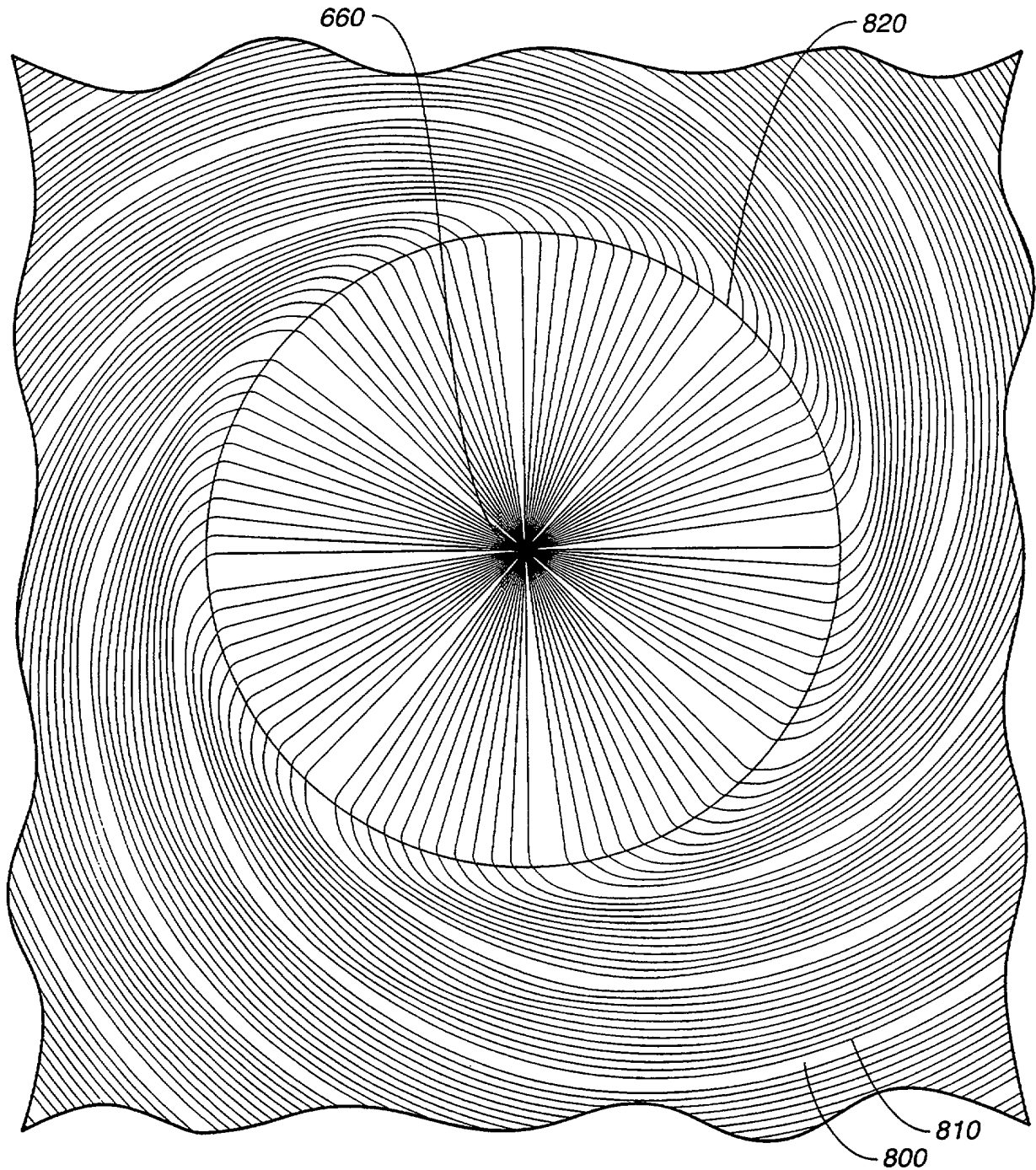

FIG. 12

INTERNATIONAL SEARCH REPORT

In. tional Application No

PCT/US 98/23661

A. CLASSIFICATION OF SUBJECT MATTER
IPC 6 G01N27/447

According to International Patent Classification (IPC) or to both national classification and IPC

B. FIELDS SEARCHED

Minimum documentation searched (classification system followed by classification symbols)

IPC 6 G01N

Documentation searched other than minimum documentation to the extent that such documents are included in the fields searched

Electronic data base consulted during the international search (name of data base and, where practical, search terms used)

C. DOCUMENTS CONSIDERED TO BE RELEVANT

Category	Citation of document, with indication, where appropriate, of the relevant passages	Relevant to claim No.
Y	WOOLLEY A T ET AL: "HIGH-SPEED DNA GENOTYPING USING MICROFABRICATED CAPILLARY ARRAY ELECTROPHORESIS CHIPS" ANALYTICAL CHEMISTRY, vol. 69, no. 11, 1 June 1997, pages 2181-2186, XP000696550 see figure 1	1, 12, 15, 31, 36
Y	WOOLLEY A T ET AL: "ULTRA-HIGH-SPEED DNA FRAGMENT SEPARATIONS USING MICROFABRICATED CAPILLARY ARRAY ELECTROPHORESIS CHIPS" PROCEEDINGS OF THE NATIONAL ACADEMY OF SCIENCES OF USA, vol. 91, November 1994, pages 11348-11352, XP002910134 see figure 1	1, 12, 15, 31, 36

Further documents are listed in the continuation of box C.

Patent family members are listed in annex.

Special categories of cited documents :

- "A" document defining the general state of the art which is not considered to be of particular relevance
- "E" earlier document but published on or after the international filing date
- "L" document which may throw doubts on priority claim(s) or which is cited to establish the publication date of another citation or other special reason (as specified)
- "O" document referring to an oral disclosure, use, exhibition or other means
- "P" document published prior to the international filing date but later than the priority date claimed

- "T" later document published after the international filing date or priority date and not in conflict with the application but cited to understand the principle or theory underlying the invention
- "X" document of particular relevance; the claimed invention cannot be considered novel or cannot be considered to involve an inventive step when the document is taken alone
- "Y" document of particular relevance; the claimed invention cannot be considered to involve an inventive step when the document is combined with one or more other such documents, such combination being obvious to a person skilled in the art.
- "&" document member of the same patent family

Date of the actual completion of the international search

8 February 1999

Date of mailing of the international search report

15/02/1999

Name and mailing address of the ISA

European Patent Office, P.B. 5818 Patentlaan 2
NL - 2280 HV Rijswijk
Tel. (+31-70) 340-2040, Tx. 31 651 epo nl.
Fax: (+31-70) 340-3016

Authorized officer

Duchatellier, M

INTERNATIONAL SEARCH REPORT

International Application No
PCT/US 98/23661

C.(Continuation) DOCUMENTS CONSIDERED TO BE RELEVANT		
Category	Citation of document, with indication, where appropriate, of the relevant passages	Relevant to claim No.
A	WO 96 35810 A (CURAGEN CORP) 14 November 1996 see abstract; figure 1 -----	1
A	WO 96 04547 A (LOCKHEED MARTIN ENERGY SYS INC ;RAMSEY J MICHAEL (US)) 15 February 1996 see abstract; figure 1 -----	1
A	WO 96 42013 A (VISIBLE GENETICS INC.) 27 December 1996 see abstract; figure 2A -----	1

INTERNATIONAL SEARCH REPORT

Information on patent family members

International Application No

PCT/US 98/23661

Patent document cited in search report	Publication date	Patent family member(s)	Publication date
WO 9635810 A	14-11-1996	AU 5855696 A	29-11-1996
		CA 2221582 A	14-11-1996
		EP 0840800 A	13-05-1998

WO 9604547 A	15-02-1996	AU 3150895 A	04-03-1996
		CA 2196429 A	15-02-1996
		CN 1168720 A	24-12-1997
		EP 0775306 A	28-05-1997
		JP 10507516 T	21-07-1998
		US 5858195 A	12-01-1999

WO 9642013 A	27-12-1996	AU 698921 B	12-11-1998
		AU 6271896 A	09-01-1997
		AU 6274696 A	09-01-1997
		CA 2222628 A	27-12-1996
		CA 2226405 A	27-12-1996
		EP 0830594 A	25-03-1998
		EP 0830595 A	25-03-1998
		WO 9642012 A	27-12-1996
