

(No Model.)

B. McHUGH.

DEVICE FOR CUTTING CARDS WITH BEVELED EDGES FOR PHOTOGRAPH MOUNTS.

No. 524,726.

Patented Aug. 21, 1894.

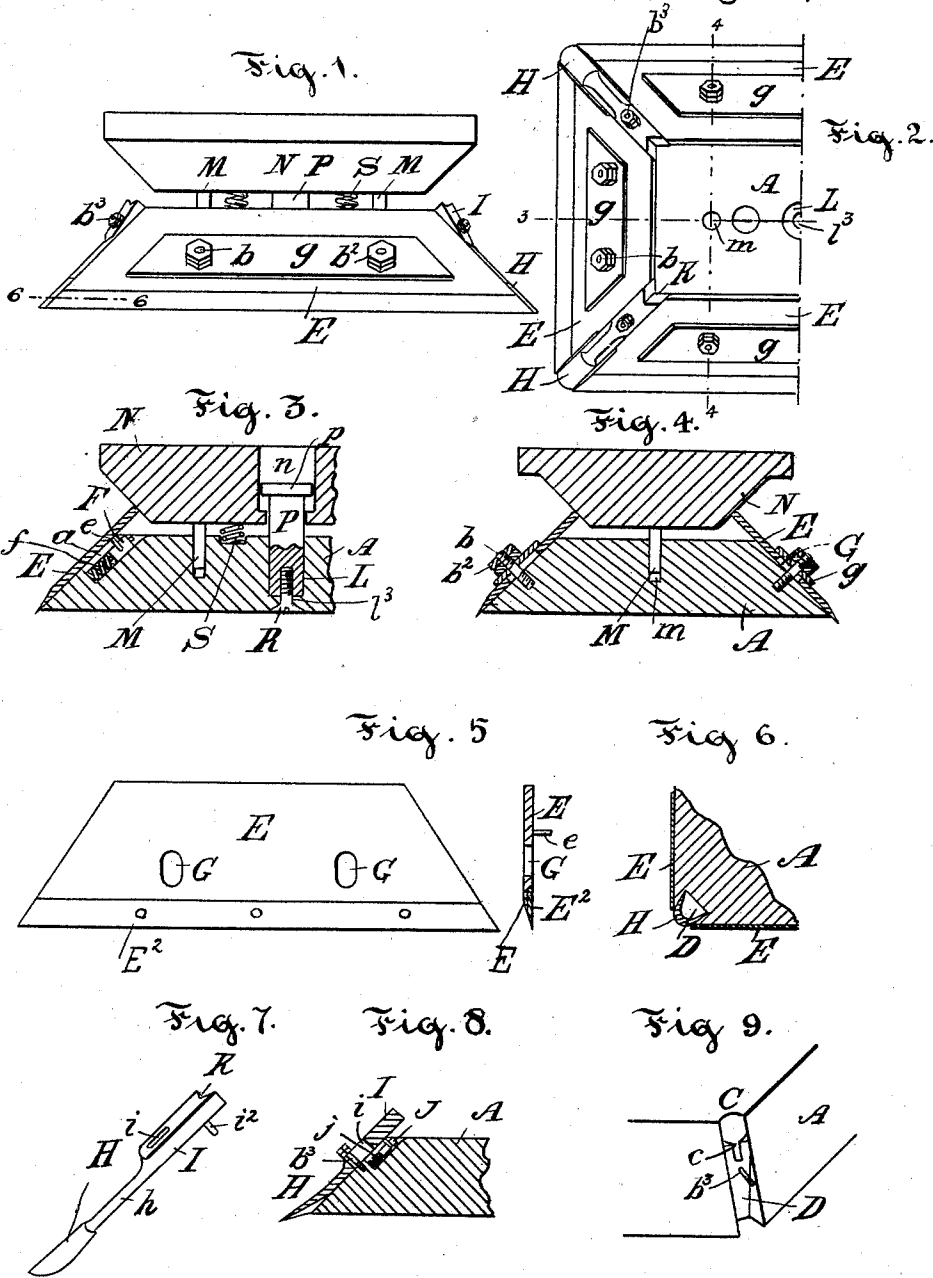

Witnesses:
 K. Foley.
 O. H. Monty.

Inventor
 Bernard M. Hugh
 Per J. Coursole
 Attorney.

UNITED STATES PATENT OFFICE.

BERNARD MCHUGH, OF OTTAWA, CANADA.

DEVICE FOR CUTTING CARDS WITH BEVELED EDGES FOR PHOTOGRAPH-MOUNTS.

SPECIFICATION forming part of Letters Patent No. 524,726, dated August 21, 1894.

Application filed December 13, 1893. Serial No. 493,526. (No model.) Patented in Canada October 25, 1893, No. 44,562.

To all whom it may concern:

Be it known that I, BERNARD MCHUGH, a subject of the Queen of Great Britain, residing at Ottawa, in the county of Carleton, in the Province of Ontario, Canada, have invented certain new and useful Improvements in Devices for Cutting Cards with Beveled Edges for Photograph-Mounts; and I do hereby declare that the following is a full, clear, and exact description of the same, reference being had to the accompanying drawings, forming a part hereof.

This device is an improvement on a device for which I obtained a Canadian patent, No. 44,562, bearing date October 25, 1893.

The object of my invention is to produce a device whereby all the sides and corners of a card may be cut simultaneously, cutting the card out of a sheet of bristol or other board at one operation, instead of, as has heretofore been the case, cutting the cards first with square edges, then piling several cards thus cut one above the other, the edges to be trimmed receding as they ascend, thus forming steps, then holding the pile thus formed in a press and trimming the edges with a scraper, this operation having to be repeated as many times as there are sides of the card.

My device consists of a die of a truncated pyramidal shape having knives on its sloping sides and angles, the knives being operated simultaneously by a block carried in a press and having a vertical movement, the said block having sloping sides impinging on the upper edges of the knives.

In the drawings,—Figure 1 is an elevation of my improved cutter, the press being omitted. Fig. 2 is a top view of the die holding the cutting knives (half only being shown). Fig. 3 is a vertical section on line 3 3, Fig. 2, showing the knives down. Fig. 4 is a vertical section on line 4 4, Fig. 2. Fig. 5 is a detail view of one of the side knives. Fig. 6 is a partial section on line 6 6, Fig. 1, showing one of the angle knives. Fig. 7 is a detail view of one of the angle knives. Fig. 8 is a section showing the manner in which the corner knives are secured. Fig. 9 is a detail view of an angle of the die.

A is a die of a truncated pyramidal shape. On each of its sloping sides are formed one or more cylindrical chambers *a* open at the

top and also open to the face of the slope. Two or more pins *b* are cast in the die projecting at right angles to the sloping sides, and are threaded on their outer ends to receive the nuts *b*².

The angles *C* formed by the junction of the sloping sides of the die are provided at their upper ends with chambers *c*, similar to though smaller than the chambers *a*, pins *b*³ are secured in the die below the chambers, the lower portions of the angles *C* are formed with a dovetailed groove *D* deep at the base of the die and running shallower as it ascends as shown in Fig. 9.

The side knives *E* lie flat against the sloping sides, their upper edges projecting above the top of the die, the outer edges of the top of the knives being slightly rounded; each of these knives is provided with one or more pins *e*, these pins are received in apertures formed in cylindrical bosses *F*, which are adapted to slide in the chambers *a*, spiral springs *f* being inserted in the bottom of the chambers, exerting an upward pressure on the pieces *F*, and so raise the knives; two or more elongated slots *G* are formed in the knife *E* for the pins *b*, and plates *g* are secured over the knives, the lock nuts *b*² holding the said plates firmly in position, leaving the knives free to slide. The cutting edge of the knives *E* may be formed of a separate piece *E*² and riveted to the main body, so as to be renewed when worn. The upper portions of the inner edges of the sides of the knives *E* are beveled to allow room for the shanks of the corner knives.

H are corner knives, the cutting edges are rounded and they are so arranged that the edges are overlapped by the side knives, the lower edges of these knives slide and fit in the dovetailed grooves *D*, a rather slender shank *h* (to facilitate placing the knife in the groove) connects the cutting portions with the head *I*, which is provided with a slot *i*, through which the pins *b*³ pass and is secured with washer and lock nuts; a pin *i*² is secured in the head which passes into an aperture in a sliding piece *J*, sliding in the chamber *c*, and provided with spiral springs *j* similar to *f*; the tops of the heads of these knives have a V-shaped groove *K*, as shown in the detail.

In the center of the die *A* is formed an ap-

erture L, open at the top and reaching nearly to the bottom, an aperture l^s of smaller dimensions connecting with the larger aperture, is reamed out at the bottom; two smaller apertures m are formed one on either side of the central aperture.

N is a block in the shape of an inverted truncated pyramid, having on its under side pins M adapted to enter the apertures m . In the center of this block is an aperture n of a diameter large enough to receive the head p of the pin P, this aperture is open at both ends, that is it passes entirely through the block but at the under side is only large enough to admit the body of the pin P, this pin passes down into the aperture L in the die A where it is secured by means of the screw R.

Spiral springs S may be inserted between the die A and block N. The block N is secured in any suitable manner to a press having a vertical movement.

The operation of my device is as follows: The knives when in their normal positions, are held by the springs so that their cutting edges are on a level with the lower edge of the die, the die being held to the block N by the pin P, when the die touches the card the block continues to descend, the sloping sides impinging on the upper edges of the side knives, and the angles engaging the V-shaped grooves on the corner knives, thus pressing the knives through the card, the head of the pin sliding up in the aperture n . The top outer edge of the side knives being rounded the pressure is on the inner side, directly over the cutting edge.

Having now fully described my invention, what I claim is—

1. A device for cutting cards with beveled edges, consisting of a die of a truncated pyramidal shape, carrying slidingly on its sloping faces, spring retracted knives, and on the angles formed by the junction of the sloping faces, spring retracted knives sliding in dovetailed grooves, the upper edges of all the said knives projecting above the upper face of the said die, a block secured loosely to the said die and adapted to be held in a press, the sloping edges of the said block impinging on

and pressing down the said knives, when pressure is applied, substantially as set forth.

2. A device for cutting cards with beveled edges, consisting of a die of a truncated pyramidal shape carrying slidingly, on its sloping faces spring retracted knives the upper edges of the said knives projecting above the upper face of the said die, a block shaped like an inverted truncated pyramid, secured loosely by means of a pin to the said die, the head of the said pin being free to slide in the said block, the sloping edges of the said block impinging on and pressing down the said knives when pressure is applied to the said block, substantially as set forth.

3. In a device for cutting cards with beveled edges, the combination with a die of a truncated pyramidal shape having chambers formed on its sloping sides to receive spiral springs of the spiral springs in said chambers, bosses sliding in the said chambers, knives carried slidingly on the said sloping sides, pins secured in the said knives and the said pins passing into apertures in the said bosses, substantially as set forth.

4. In a device for cutting cards with beveled edges, the combination with the die A carrying spring retracted knives on its sloping sides and on the angles made by the junction of the said sloping sides; of the block N having guide pins M and P adapted to enter apertures in the said die A, the head of the said pin P sliding in the aperture n in the said block the said aperture being smaller at its lower end, substantially as set forth.

5. In a device for cutting cards with beveled edges, the combination, with a die of a truncated pyramidal shape, carrying spring retracted knives on its sloping sides, of the corner knives H, sliding in dovetailed grooves D, the top of these knives having V-shaped grooves K, and means for retracting the said knives, substantially as set forth.

Signed at Ottawa this 13th day of November, 1893.

BERNARD MCHUGH.

In presence of—
K. FOLEY,
E. H. MONTY.