

J. STROBEL.  
 LIFE PRESERVER.  
 APPLICATION FILED AUG. 13, 1910.

1,001,476.

Patented Aug. 22, 1911.

2 SHEETS—SHEET 1.

*Fig. 1.*

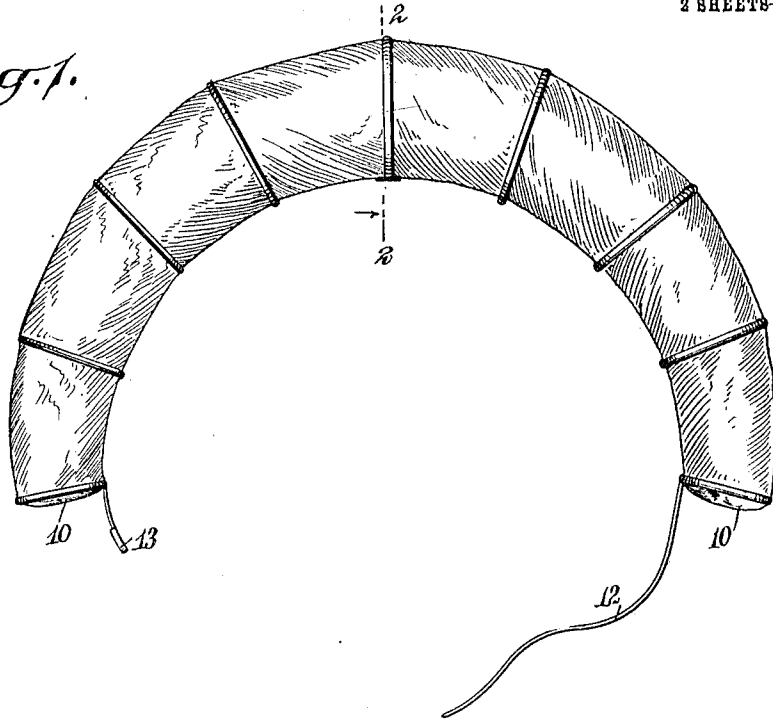

*Fig. 2.*

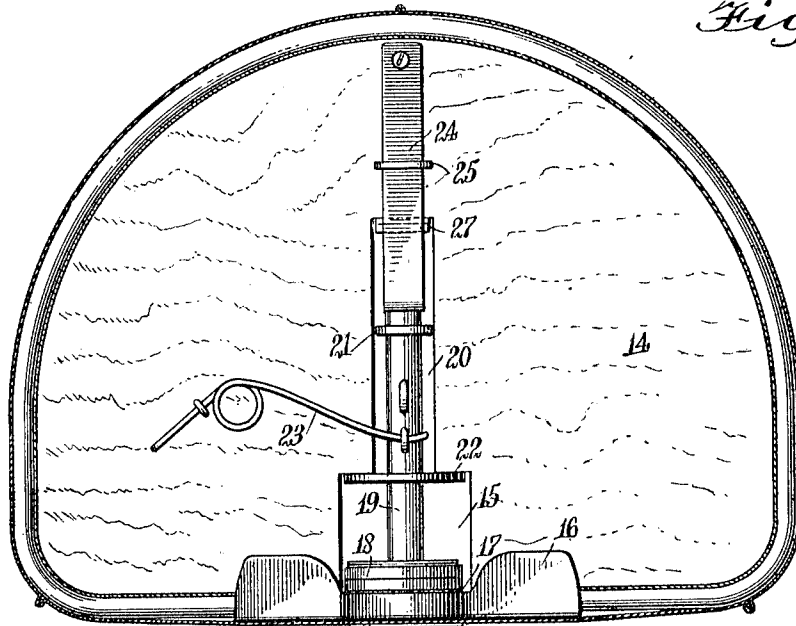

WITNESSES:

*Geo W. Maylor*  
*C. M. Fairbank*

INVENTOR  
*Jacob Strobel*  
 BY *Mumford*  
 ATTORNEYS

J. STROBEL.  
 LIFE PRESERVER.  
 APPLICATION FILED AUG. 13, 1910.

1,001,476.

Patented Aug. 22, 1911.

2 SHEETS—SHEET 2.

*Fig. 3.*

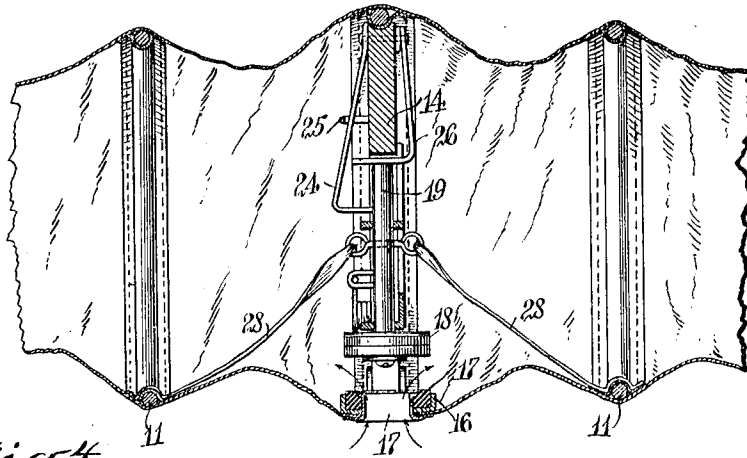

*Fig. 4.*

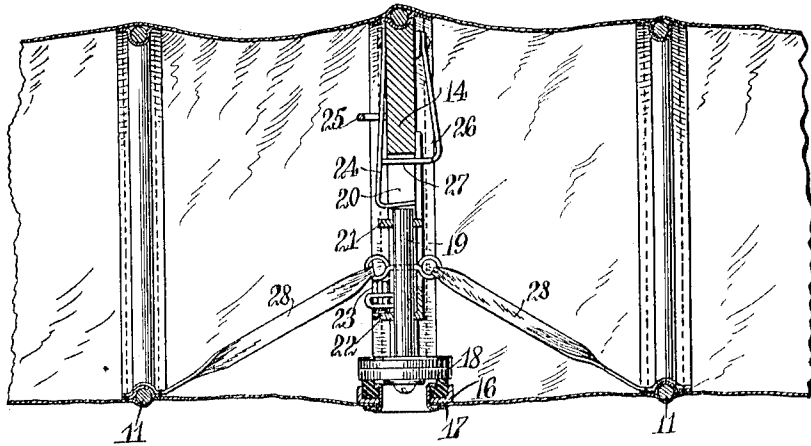

*Fig. 5.*

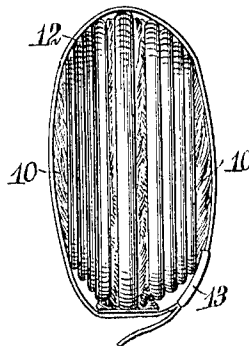

WITNESSES:

*J. W. Taylor*  
*C. W. Fairbanks*

INVENTOR  
*Jacob Strobel*  
 BY *Munn Co.*  
 ATTORNEYS

# UNITED STATES PATENT OFFICE.

JACOB STROBEL, OF NEW YORK, N. Y.

LIFE-PRESERVER.

1,001,476.

Specification of Letters Patent. Patented Aug. 22, 1911.

Application filed August 13, 1910. Serial No. 576,950.

To all whom it may concern:

Be it known that I, JACOB STROBEL, a citizen of the United States, and a resident of the city of New York, borough of Manhattan, in the county and State of New York, have invented a new and Improved Life-Preserver, of which the following is a full, clear, and exact description.

This invention relates to certain improvements in life preservers, and more particularly to that type which includes an air chamber normally deflated but adapted to be inflated and closed prior to the time of use.

My invention is particularly applicable to life belts, and the main feature of the invention involves the automatic closing of a normally open air inlet valve by the securing of the life belt in position upon the person. In my improved construction, the life belt is mechanically distended when being strapped on, and this mechanical distension draws air into the air chamber, and then automatically closes the air inlet valve, to prevent the escape of the air or the entrance of water.

Reference is to be had to the accompanying drawings forming a part of this specification, in which similar characters of reference indicate corresponding parts in all the views, and in which—

Figure 1 is a plan view of a life belt constructed in accordance with my invention; Fig. 2 is a transverse enlarged section on the line 2—2 of Fig. 1; Fig. 3 is a longitudinal section through a portion of the life belt during the first stages of the distending of the latter; Fig. 4 is a section similar to Fig. 3, but showing the parts fully distended and the valve closed; and Fig. 5 is a side elevation showing the parts completely collapsed.

My invention is applicable to various different types of life preservers which support the person by means of an air chamber, but it is particularly applicable to life belts.

In the specific form illustrated, I provide a tubular belt formed of any suitable waterproof material. The air chamber within the belt is closed at its ends by suitable end walls 10, and along the length of the belt are a plurality of separate and independent reinforcing braces 11. Each brace extends circumferentially of the tube forming the belt, and each holds its adjacent portion of the belt distended. In collapsing the belt,

the several reinforcing braces are brought together, as the material between each brace and the next successive one is freely folded or bent.

The belt may be secured to the person in any suitable manner, but as illustrated, one end has a strap 12, which may be secured to a suitable buckle or loop 13 at the opposite end of the belt. Preferably, the sections of the material between successive reinforcing braces is so formed that when the belt is fully distended, it will assume a position in the arc of a circle, as illustrated in Fig. 1. Each reinforcing brace may be substantially semi-circular; that is, it may have one flat side, which comes at the inner peripheral side of the belt, as is indicated in Fig. 2. This permits the belt to better adapt itself to the form of the wearer when it is strapped in place. The same strap which holds the belt in place may be employed for holding the belt in collapsed position, as indicated in Fig. 5.

Intermediate the ends of the belt, there is provided a reinforcing brace in the form of a partition 14, of wood or other similar material, which serves to support the construction embodying the main important feature of my invention. This partition is provided with an aperture 15 therethrough adjacent the inner edge, and below this aperture is a transverse member 16 rigidly secured to the edge of the brace, and provided with a central aperture, constituting an air inlet port 17. At the inner edge of this member and surrounding the port, there is mounted a gasket constituting a valve seat. For closing this port, I provide a valve 18, mounted on a valve stem 19, which latter is movable outward radially within a slot 20 in the frame or partition 14.

The valve stem is guided in two transverse braces 21 and 22, and is normally held upwardly in open position by a suitable spring 23 mounted on the frame or partition 14. At the upper end of the valve stem, there is a retainer 24 in the form of a spring, secured at the upper edge of the partition and held within a suitable guide 25. The lower end of this retainer is bent to extend transversely through the slot 20, and is so positioned as to enter the slot above the end of the valve stem when the latter is moved downwardly to close the valve. When in this position, as illustrated in Figs. 2 and 4, the valve will be held against its seat and

against the tension of the spring 23. On the opposite side of the frame or partition 14 is a device for moving the retainer to inoperative position and permitting the valve to open. This device is in the form of a plate 26 secured adjacent the outer edge of the partition and having a depending lower end 27 adapted to enter the slot 20 and press the retainer outwardly to inoperative position. This device may be of spring metal, or it may merely operate against the tension of the spring member 24. For closing the valve, I provide two flexible connecting members 28, 28, which may be in the form of tape, and each of which has one end connected to the valve stem and the other end connected to an adjacent reinforcing brace 11. The length of these members is such that when the life belt is distended by the pulling apart of the braces, the tension of the members 28 will pull the valve downwardly to its seat, and the retainer 24 will hold it there.

My improved device may normally remain in the collapsed position indicated in Fig. 5, and the valve will normally be open. When it is desired to put on the life belt, it is only necessary to distend the belt to the position indicated in Fig. 1, and secure the strap to hold the belt in position. During the distending operation, the air inlet valve will be open, and air will freely enter the interior of the belt. The annular reinforcing braces hold the parts of the belt in extended position, so that the air will be compelled to enter. During the final portion of the distending movement, the two reinforcing braces, 11, 11, upon opposite sides of the central brace or partition 14, will draw upon the two members 28, 28, and pull the valve down to its closed position, thus entrapping the air within the air chamber. As the valve reaches its seat, the retainer 24 will swing into position in the rear of the valve stem and lock the valve closed, so that the air within the belt cannot escape and water cannot enter.

The device is entirely automatic in its operation, as the valve does not have to be opened or closed mechanically, nor are there any other parts which require manipulation. The entire operation results from the simple act of buckling the life preserver in position. When it is desired to deflate the life preserver, it is only necessary to grasp the central partition 14 between the thumb and finger, one of them coming against the member 26, and the other against the guide 25. Upon applying sufficient pressure, the member 26 will force the retaining member 24

outwardly, and the spring 23 will open the valve, so that the air may escape while the device is being folded up.

Having thus described my invention, I claim as new and desire to secure by Letters Patent:—

1. A life preserver, having an air chamber provided with an inlet port, a valve controlling said port, a retainer for holding said valve in closed position, and means within said air chamber and operable from the exterior thereof, for moving said retainer to inoperative position.

2. A life preserver, having an air chamber provided with an inlet port, a valve controlling said port, a retainer for holding said valve in closed position, means within said air chamber and operable from the exterior thereof for moving said retainer to inoperative position, and means controlled by the distending of the preserver, for closing said valve.

3. A life preserver, having an air chamber, a transverse partition therein, an air inlet valve, a member upon one side of said partition for retaining a valve in a predetermined position, and a member upon the opposite side of the partition for moving said retainer to inoperative position.

4. A life preserver, having an air chamber, a transverse partition therein, an air inlet valve, a member upon one side of said partition for retaining a valve in a predetermined position, a member upon the opposite side of the partition for moving said retainer to inoperative position, and a spring for moving said valve to a second predetermined position.

5. In a life belt, an air chamber having an inlet port, a transverse partition in said chamber, a valve within said belt seated in said partition and closing said port, and mechanism on said partition locking said valve in place.

6. In a life belt, an air chamber having an inlet port, a partition in said chamber, a valve seated in said partition and closing said port, mechanisms on said partition locking said valve in place, and means within the belt operable externally of said belt to place said mechanisms in non-operable position.

In testimony whereof I have signed my name to this specification in the presence of two subscribing witnesses.

JACOB STROBEL.

Witnesses:

MAX HAHN,  
CHARLES HERMANN.