



US00D779309S

(12) **United States Design Patent**
Morris

(10) **Patent No.:** **US D779,309 S**

(45) **Date of Patent:** **** Feb. 21, 2017**

(54) **GASOLINE FLOW CONTROL DEVICE**

(71) Applicant: **Donald A. Morris**, Crawfordsville, IN (US)

(72) Inventor: **Donald A. Morris**, Crawfordsville, IN (US)

(**) Term: **15 Years**

(21) Appl. No.: **29/549,290**

(22) Filed: **Dec. 21, 2015**

Related U.S. Application Data

(62) Division of application No. 29/493,358, filed on Jun. 9, 2014, now Pat. No. Des. 751,884.

(51) **LOC (10) Cl.** **08-08**

(52) **U.S. Cl.**

USPC **D8/349**; D3/210; D8/354

(58) **Field of Classification Search**

USPC D11/1-2, 14, 26-29, 89-92, 44, 48, 81, D11/99; 63/26-28, 32; D3/207-212; D8/16, 38, 347, 348, 349, 354, 395; 70/456 B, 457, 458, 456 R; 206/37.1, 37; D14/434, 435, 435.1, 436, 439, 480.3, D14/480.1, 480.5, 480.7; D24/174, 173, D24/480.3; 141/392

CPC A45C 11/32; A47G 29/10; B65B 1/04; B65B 3/04

See application file for complete search history.

(56) **References Cited**

U.S. PATENT DOCUMENTS

3,360,229 A * 12/1967 Beyer A47G 1/20
248/339
4,095,629 A 6/1978 Jordan
4,175,595 A 11/1979 Noe
D254,050 S * 1/1980 Fitzgerald 141/392
4,200,128 A * 4/1980 Pokrzywa B67D 7/50
141/392

D255,321 S * 6/1980 Stelman 141/392
4,206,791 A 6/1980 Bower
D258,114 S * 2/1981 Maynor, Jr. D15/9.1
D266,905 S * 11/1982 Wallis D32/40
4,487,238 A 12/1984 Carder, Sr.
D282,048 S * 1/1986 Scanlon D8/349
D282,240 S * 1/1986 Gilford D8/349
4,683,923 A 8/1987 Harris
4,690,182 A 9/1987 Knaus
4,722,375 A * 2/1988 Fox B67D 7/50
141/392
D297,110 S * 8/1988 Zagorski 141/392

(Continued)

Primary Examiner — Ralf Seifert

(74) *Attorney, Agent, or Firm* — Woodard Emhardt
Moriarty McNett & Henry LLP

(57) **CLAIM**

The ornamental design for a gasoline flow control device, as shown and described.

DESCRIPTION

FIG. 1 is a perspective view of the gasoline flow control device showing my new design;
FIG. 2 is a front elevational view thereof;
FIG. 3 is a rear elevational view thereof;
FIG. 4 is a right side elevational view thereof;
FIG. 5 is a left side elevational view thereof;
FIG. 6 is a top plan view thereof; and
FIG. 7 is a bottom plan view thereof.
FIG. 8 is a perspective view of the gasoline flow control device showing the second embodiment of my new design;
FIG. 9 is a front elevational view of FIG. 8;
FIG. 10 is a rear elevational view of FIG. 8;
FIG. 11 is a right side elevational view of FIG. 8;
FIG. 12 is a left side elevational view of FIG. 8;
FIG. 13 is a top plan view of FIG. 8; and,
FIG. 14 is a bottom plan view of FIG. 8.

The broken lines are for illustrative purposes only and form no part of the claimed design.

1 Claim, 6 Drawing Sheets

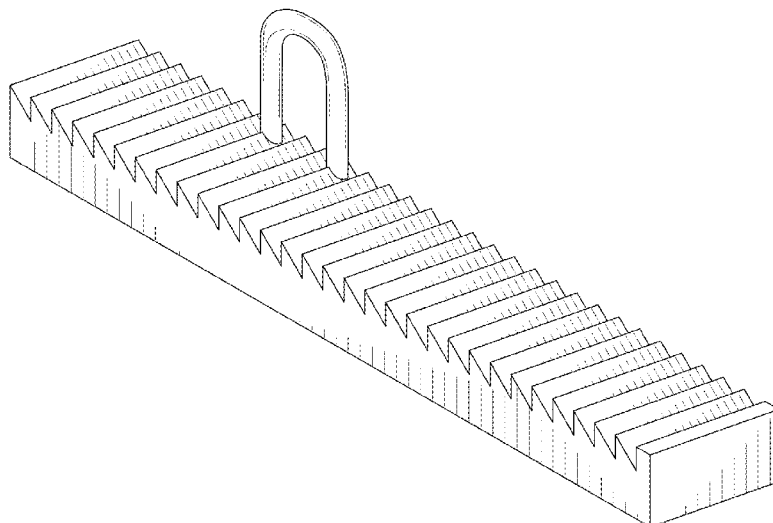

(56)

References Cited

U.S. PATENT DOCUMENTS

D298,212	S *	10/1988	Gross	D15/9.1
D298,213	S *	10/1988	Iati	141/392
D301,973	S *	7/1989	Parella	141/292
4,917,308	A	4/1990	Manhardt et al.	
D312,172	S *	11/1990	Ambrosio	D3/210
4,986,321	A	1/1991	Nitzberg et al.	
5,067,533	A	11/1991	Carder, Sr. et al.	
5,199,474	A	4/1993	D'Angelo	
5,273,087	A	12/1993	Koch et al.	
5,289,856	A	3/1994	Strock et al.	
D370,170	S *	5/1996	Lambourne	D8/349
6,167,903	B1	1/2001	Newman	
6,279,621	B1 *	8/2001	Gelsomino	B67D 7/50
				141/1
6,418,988	B1 *	7/2002	Palumbo	B67D 7/50
				141/392
D495,239	S *	8/2004	Neal, III	D8/349
6,830,086	B2 *	12/2004	Smith	B67D 7/50
				141/392
D508,841	S *	8/2005	Jordan, Jr.	D8/395
D514,923	S *	2/2006	Brown	D8/354
7,040,361	B2 *	5/2006	Soussan	B67D 7/50
				141/392
7,159,625	B1	1/2007	Klutts	
D569,241	S *	5/2008	O'Neill	D8/395
7,909,304	B1 *	3/2011	Lombardo	F16K 35/06
				141/392
2002/0185622	A1	12/2002	Bruns	

* cited by examiner

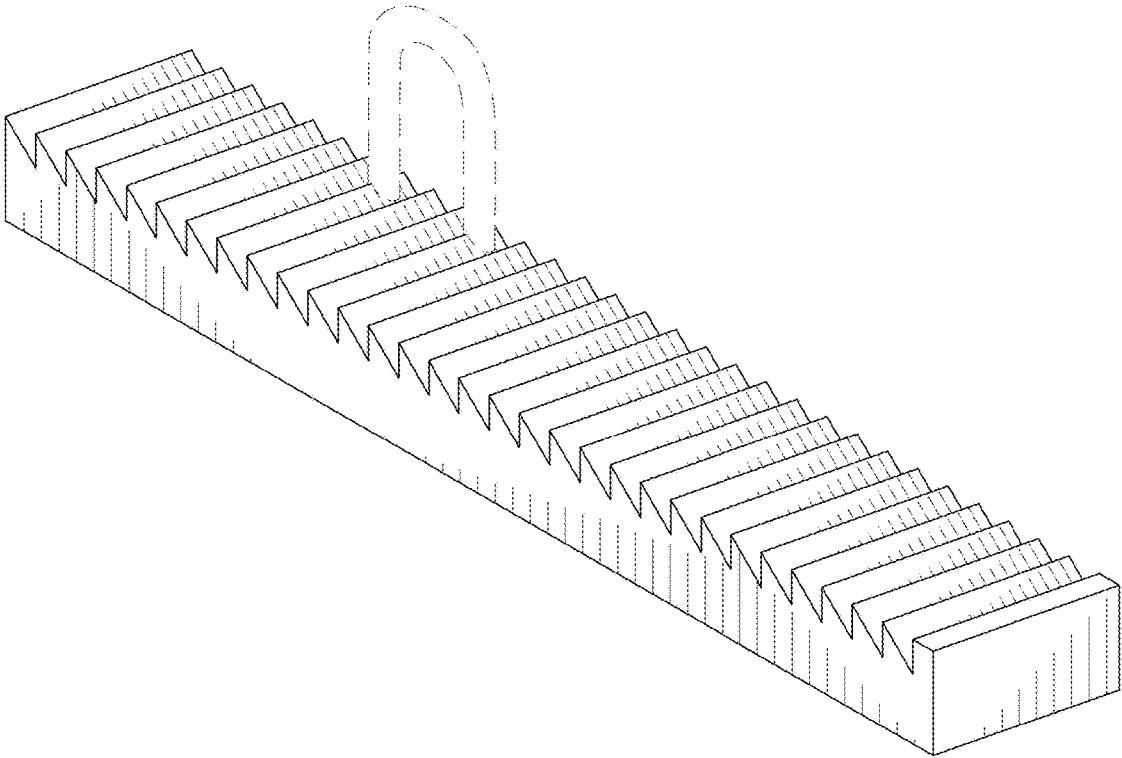

FIG. 1

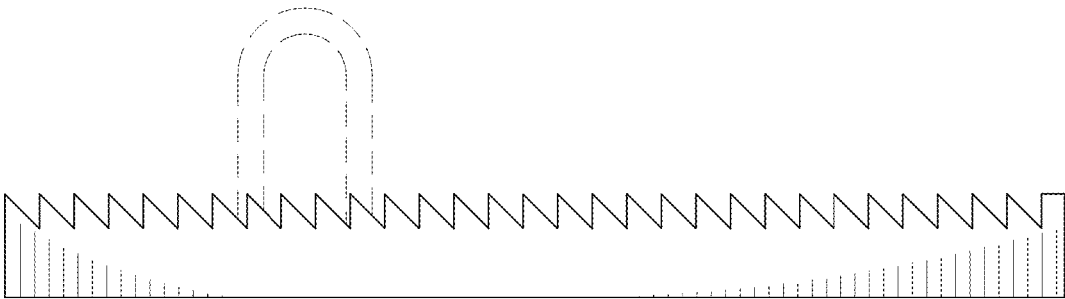

FIG. 2

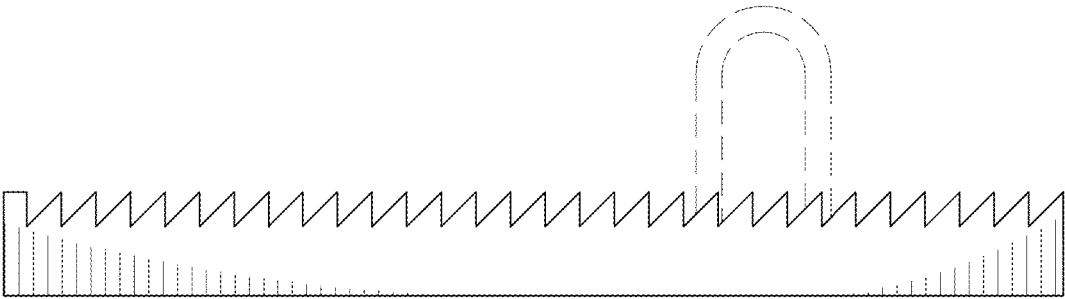

FIG. 3

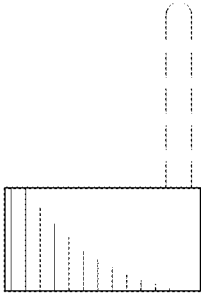

FIG. 4

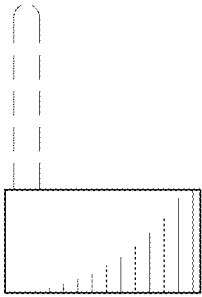

FIG. 5

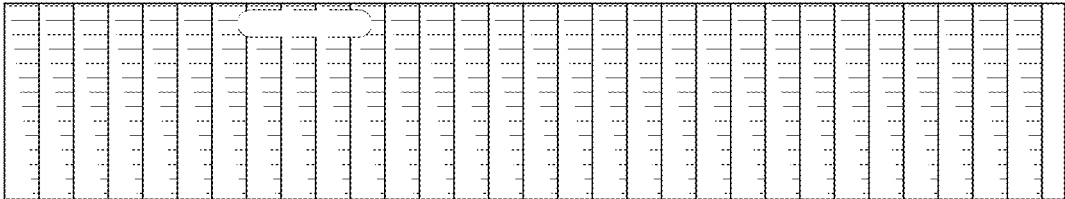

FIG. 6

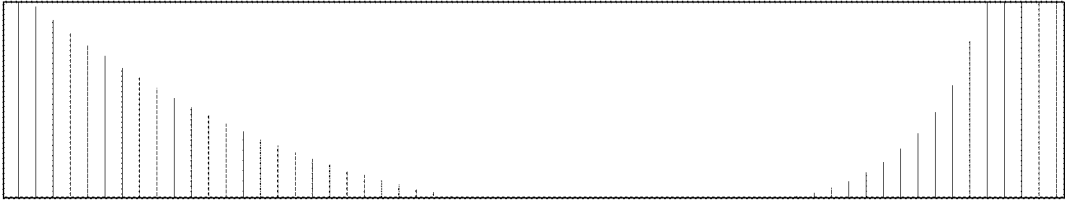

FIG. 7

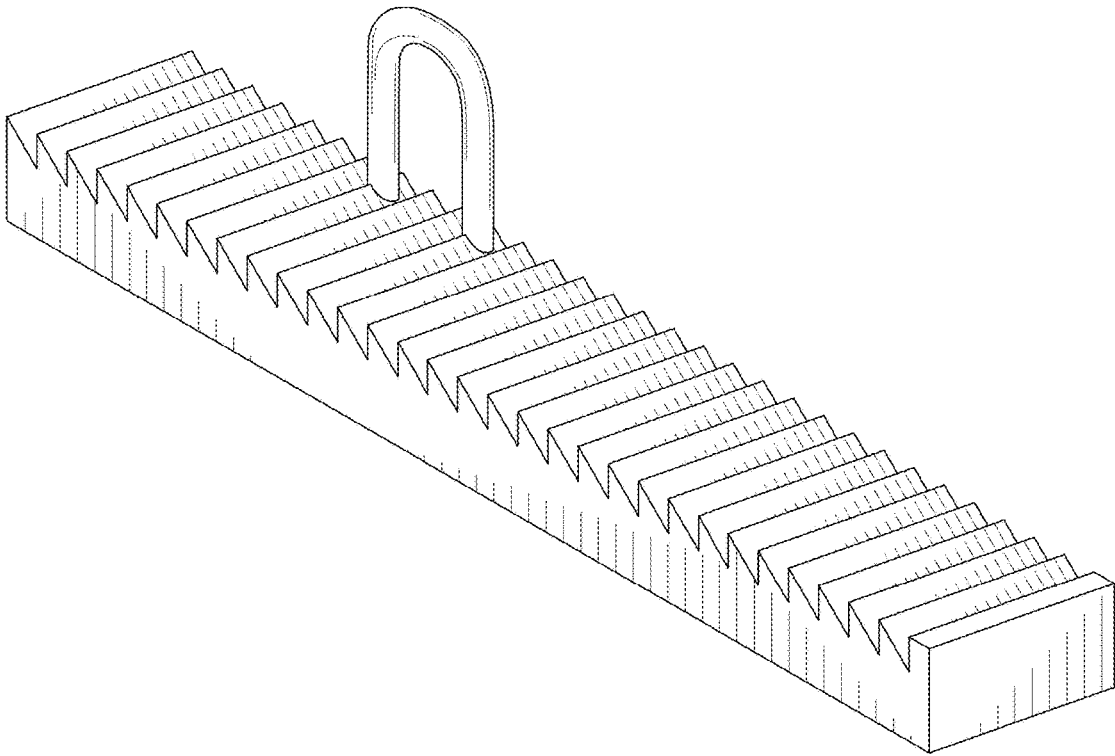

FIG. 8

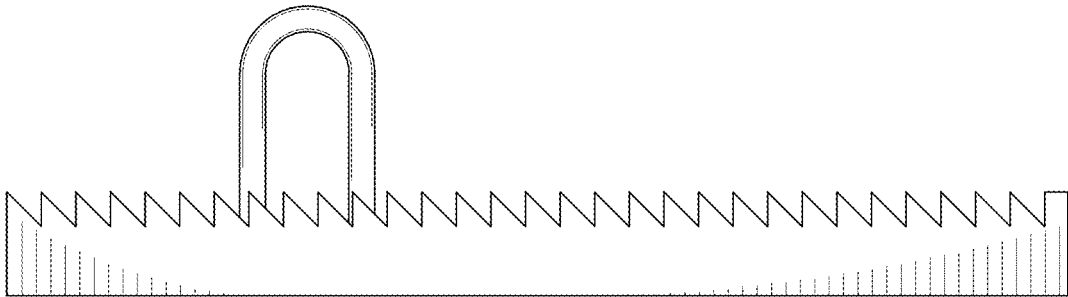

FIG. 9

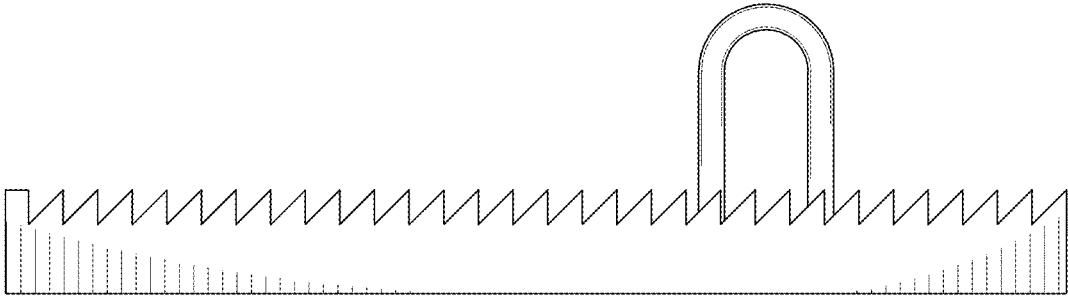

FIG. 10

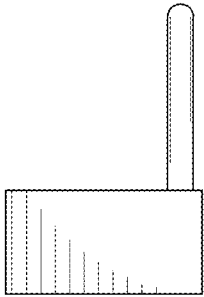

FIG. 11

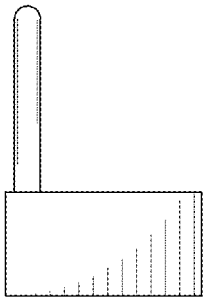

FIG. 12

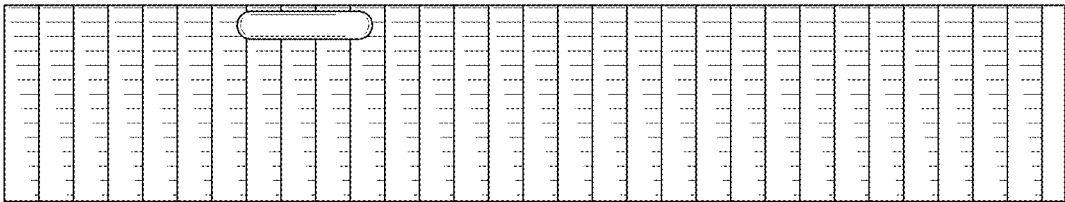

FIG. 13



FIG. 14