



INTERNATIONAL APPLICATION PUBLISHED UNDER THE PATENT COOPERATION TREATY (PCT)

<p>(51) International Patent Classification <sup>6</sup> : <b>G11B 7/007, 27/36</b></p>	<p><b>A1</b></p>	<p>(11) International Publication Number: <b>WO 97/50081</b> (43) International Publication Date: 31 December 1997 (31.12.97)</p>
<p>(21) International Application Number: PCT/IB97/00660 (22) International Filing Date: 9 June 1997 (09.06.97)</p> <p>(30) Priority Data: 96201760.4 27 June 1996 (27.06.96) EP (34) Countries for which the regional or international application was filed: NL et al. 96203289.2 22 November 1996 (22.11.96) EP (34) Countries for which the regional or international application was filed: NL et al.</p> <p>(71) Applicant: PHILIPS ELECTRONICS N.V. [NL/NL]; Groenewoudseweg 1, NL-5621 BA Eindhoven (NL). (71) Applicant (for SE only): PHILIPS NORDEN AB [SE/SE]; Kottbygatan 7, Kista, S-164 85 Stockholm (SE). (72) Inventor: HEEMSKERK, Jacobus, Petrus, Josephus; Prof. Holstlaan 6, NL-5656 AA Eindhoven (NL). (74) Agent: FAESSEN, Louis, M., H.; Internationaal Octrooibureau B.V., P.O. Box 220, NL-5600 AE Eindhoven (NL).</p>		<p>(81) Designated States: CN, HU, JP, KR, RU, European patent (AT, BE, CH, DE, DK, ES, FI, FR, GB, GR, IE, IT, LU, MC, NL, PT, SE).</p> <p><b>Published</b> <i>With international search report. Before the expiration of the time limit for amending the claims and to be republished in the event of the receipt of amendments.</i></p>

(54) Title: INFORMATION CARRIER CONTAINING AUXILIARY INFORMATION, READING DEVICE AND METHOD OF MANUFACTURING SUCH AN INFORMATION CARRIER

(57) Abstract

A system for controlled reproduction of information according to the invention comprises an information carrier and a reading device. The information carrier contains information in blocks written in a track. The information carrier has reference patterns which divide the track into sectors for writing the information blocks, and auxiliary information written in the reference patterns. The auxiliary information is related to the information, for example, a decoding key, access code or digital signature. The reading device comprises a demodulation means for recovering both the information and the auxiliary information. The device may include means for processing the information and/or auxiliary information in dependence on the auxiliary information. Since the auxiliary information cannot be transferred to an illegal copy, this copy is unusable.

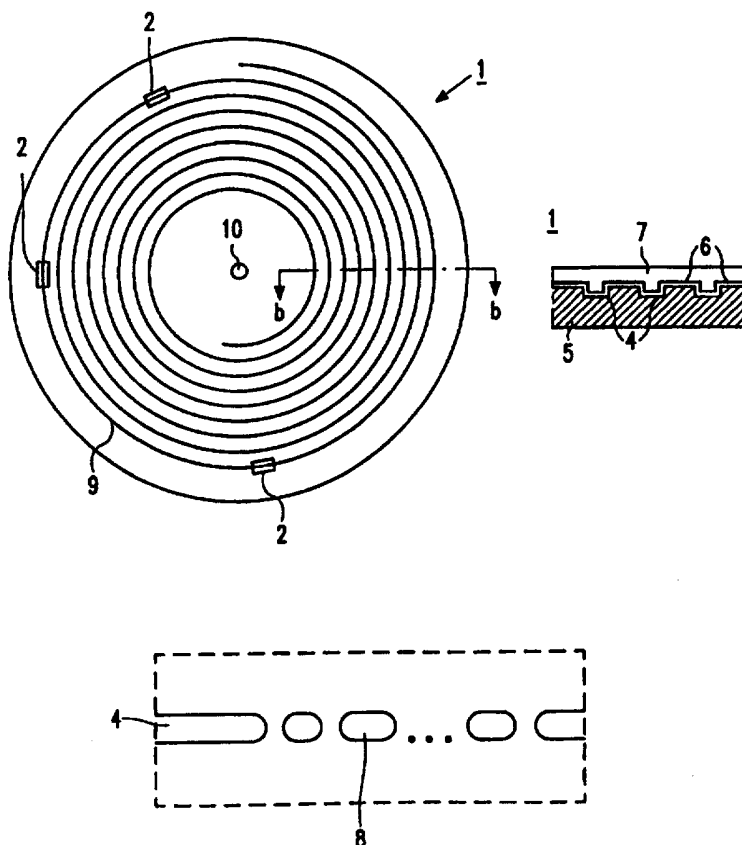

*FOR THE PURPOSES OF INFORMATION ONLY*

Codes used to identify States party to the PCT on the front pages of pamphlets publishing international applications under the PCT.

AL	Albania	ES	Spain	LS	Lesotho	SI	Slovenia
AM	Armenia	FI	Finland	LT	Lithuania	SK	Slovakia
AT	Austria	FR	France	LU	Luxembourg	SN	Senegal
AU	Australia	GA	Gabon	LV	Latvia	SZ	Swaziland
AZ	Azerbaijan	GB	United Kingdom	MC	Monaco	TD	Chad
BA	Bosnia and Herzegovina	GE	Georgia	MD	Republic of Moldova	TG	Togo
BB	Barbados	GH	Ghana	MG	Madagascar	TJ	Tajikistan
BE	Belgium	GN	Guinea	MK	The former Yugoslav Republic of Macedonia	TM	Turkmenistan
BF	Burkina Faso	GR	Greece			TR	Turkey
BG	Bulgaria	HU	Hungary	ML	Mali	TT	Trinidad and Tobago
BJ	Benin	IE	Ireland	MN	Mongolia	UA	Ukraine
BR	Brazil	IL	Israel	MR	Mauritania	UG	Uganda
BY	Belarus	IS	Iceland	MW	Malawi	US	United States of America
CA	Canada	IT	Italy	MX	Mexico	UZ	Uzbekistan
CF	Central African Republic	JP	Japan	NE	Niger	VN	Viet Nam
CG	Congo	KE	Kenya	NL	Netherlands	YU	Yugoslavia
CH	Switzerland	KG	Kyrgyzstan	NO	Norway	ZW	Zimbabwe
CI	Côte d'Ivoire	KP	Democratic People's Republic of Korea	NZ	New Zealand		
CM	Cameroon		Republic of Korea	PL	Poland		
CN	China	KR	Republic of Korea	PT	Portugal		
CU	Cuba	KZ	Kazakstan	RO	Romania		
CZ	Czech Republic	LC	Saint Lucia	RU	Russian Federation		
DE	Germany	LI	Liechtenstein	SD	Sudan		
DK	Denmark	LK	Sri Lanka	SE	Sweden		
EE	Estonia	LR	Liberia	SG	Singapore		

Information carrier containing auxiliary information, reading device and method of manufacturing such an information carrier.

The invention relates to an information carrier which comprises a track for writing patterns which represent information in a predefined manner and for writing related auxiliary information.

5 The invention further relates to a reading device for reproducing information from an information carrier, the information carrier comprising a track for writing patterns which represent information in a predefined manner and for writing related auxiliary information. the device comprising reading means for reading the patterns, and a demodulation means for recovering the information from the read signal in a predefined manner, and means for recovering the auxiliary information.

10 The invention further relates to a method of manufacturing an information carrier which comprises a track for writing patterns which represent information in a predefined manner and for writing related auxiliary information, the auxiliary information being determined in dependence on the information.

15 Such an information carrier and reading device are known from EP-0545472. The known information carrier comprises a prearranged guiding track, a so-called pregroove. In the track determined by the pregroove, information which is written in a predefined manner is represented in optically readable patterns which are formed by variation  
20 of a first physical parameter, such as the height of the scanned surface. The pregroove has variations in a second physical parameter, such as an excursion in transverse direction, also denoted as wobble. Pregroove wobble is FM modulated and this modulation represents auxiliary information which is related to the information such as, for example, a descramble code for recovering information stored as scrambled information. The known device  
25 comprises reading means for reading the patterns and recovering means for recovering the auxiliary information. The known device and information carrier form a system for controlled information reproduction. For this purpose, the device comprises means for reproducing the information in dependence on the auxiliary information. If the information is copied on a writable information carrier, the information of this copy will not be reproduced,

because during the writing process only the patterns are written and the copy itself does not contain any auxiliary information.

A problem in the known device is that auxiliary information is to be recovered from variations in a second physical parameter, which parameter represents auxiliary information in a manner different from the written patterns. As a result, the means for recovering the auxiliary information are complex.

It is an object of the invention to provide means for reproducing information in a controlled manner, in which auxiliary information can be recovered in a simple and cost-effective manner. For this purpose, the information carrier according to the invention is characterized in that the information carrier comprises reference patterns which divide the track into areas for writing the information in blocks, which reference patterns represent the auxiliary information in the predefined manner. For this purpose, the reading device according to the invention is characterized in that the demodulation means comprises the means for recovering the auxiliary information from reference patterns available on the information carrier, which reference patterns divide the track into areas for writing the information in blocks. For this purpose, a method according to the invention is characterized in that the information carrier is provided with reference patterns which divide the track into areas for writing the information in blocks, which reference patterns represent the auxiliary information in the predefined manner.

The measures according to the invention may lead to recovering the auxiliary information from the information carrier via the demodulation means, because both the information and the auxiliary information is represented in the predefined manner. This is advantageous in that the means for recovering the auxiliary information may be simple.

A further embodiment of the information carrier according to the invention is characterized in that the auxiliary information comprises check information related to a function of the information, which check information is to be applied when the information is processed for the function to be executed. This is advantageous in that the use of the information, such as video information, or a computer program, depends on the auxiliary information. As a result, a copy of the information carrier without the auxiliary information is unusable.

A further embodiment of the information carrier according to the invention is characterized in that the information carrier is of a writable type on which the

information can be written via a writing process, while the reference patterns are not erasable. The information carrier may, for example, be one of an optically readable type for which the reference patterns are to be written once or are written in a non-erasable manner during the manufacturing process. This is advantageous in that the auxiliary information  
5 cannot be changed any more.

A further embodiment of the information carrier according to the invention is characterized in that the reference patterns contain marks whose centers are shifted relative to the middle of the track. A standard writing device will not be designed for introducing marks on shifted positions. This is advantageous in that a copy which includes  
10 auxiliary information cannot be made on such a standard writing device.

A further embodiment of the information carrier according to the invention is characterized in that the reference patterns are present only in a predetermined part of the track. This is advantageous in that the part of the track not comprising reference patterns may be formatted according to an existing information recording standard, such as  
15 DVD-ROM. The predetermined part, e.g. located in a lead-in area, comprising the auxiliary information will be read only by a reading device according to the invention, while undisturbed reading of information according to the standard by a standard reading device is possible.

An embodiment of the reading device according to the invention is  
20 characterized in that the device comprises means for processing the information and/or the auxiliary information in dependence on the auxiliary information. The information may then be coded (scrambled or encrypted), and the auxiliary information may comprise a decoding key. This is advantageous in that the reading device is capable of decoding the information and/or auxiliary information, whereas a standard reading device does not have access to the  
25 information. Moreover, the reading device according to the invention may read and process the auxiliary information, while not making the auxiliary information as such available to the user on an output of the device. This is advantageous in that the auxiliary information cannot be accessed by a user for creating illegal copies.

A further embodiment of the reading device according to the invention is  
30 characterized in that the auxiliary information contains check information related to a function of the information, and in that the information processing means are arranged for executing the function in dependence on the check information. This is advantageous in that the processing of the information, such as video information, or a computer program, is dependent on the auxiliary information. As a result, a copy of the information carrier without

the auxiliary information is unusable, which provides a protection against illegal copies.

A further embodiment of the reading device according to the invention is characterized in that the device comprises means for detecting the position of the reference patterns relative to the track or other reference patterns. This is advantageous in that an  
5 illegal copy of controlled information comprising the reference patterns can be detected if the reference patterns are not positioned correctly, e.g. not shifted transversely, or not aligned in adjacent windings of the track.

These and other aspects of the invention will be apparent from and elucidated with reference to the embodiments described hereinafter.

10

In the drawings:

Fig. 1 shows an information carrier of a writable type,

Fig. 2 diagrammatically shows a reference pattern,

15

Fig. 3 shows a reading device for reproducing information,

Fig. 4 shows a reading device for reproducing and processing

information, and

Fig. 5 shows an arrangement for reproducing and processing a computer program.

20

In the drawing Figures, like elements which have already been described carry like reference characters.

Fig. 1a shows a disc-shaped information carrier 1 of an optically readable  
25 type. The information carrier comprises a track 9 intended for writing, which track is arranged in a helical pattern of windings. The windings may also be arranged concentrically in lieu of helically. The track 9 is indicated on the information carrier by a servopattern for enabling a read/write head to follow the track 9 during the scanning operation, which servopattern, for example, may be formed by a pregroove. A servopattern may also  
30 comprise, for example, regularly divided sub-patterns which periodically cause signals to occur in a tracking servo. Fig. 1b shows a section along line b-b of the information carrier 1, in which a transparent substrate 5 is covered by a recording layer 6 and a protective layer 7. The pregroove 4 may also be arranged as a raised part or have a material property different from its surroundings. Furthermore, it is possible to write the information

alternately in a lowered or in a raised portion, a so-called Groove and Land servopattern. In that case, the lowered pregroove 4 (Groove) is as wide as the raised portion (Land) lying in between, and in the servopattern there is a change from land to groove or vice versa usually once per winding. Information on the information carrier is represented by patterns of optically readable marks. For example, the position and/or the length of the marks then represent a binary information signal. The marks may be introduced by presses, as is customary for read-only CDs, such as CD-ROM on which the pressed marks represent the information and provide the servopattern. In the case of a writable information carrier 1, the recording layer 6 can be optically or magneto-optically written by a device for writing information blocks. For forming patterns in the track 9, each mark is formed by one or more write pulses of a constant or a varying writing power which depends on, for example, the length of the mark. An example of a writable information carrier is the CD erasable which has a layer of phase-change material.

Reference patterns 2, which divide the track into areas, so-called sectors, for writing the information in blocks, are uniformly spaced in the servopattern. The sectors between the reference patterns 2 may be selected so short that a practicably usable amount of information fits into a sector as a block, for example, 512 byte or 2 Kbytes. A larger unit may also comprise a number of such units of e.g. 2 kByte and have a total length of e.g. 16 or 32 Kbyte. The larger unit may contain additional symbols for error correction, which error correction operates over the total length which is large relative to the errors to be expected. As a result, it is impossible to select a error-correctable unit arbitrarily small. In practice, a number of reference patterns per winding will be used. Fig. 1 shows only a few reference patterns 2.

Fig. 1c shows a reference pattern 2. The reference pattern 2 contains address information related to the location on the information carrier. The address information, gives, for example, the address of the sector situated behind the reference pattern and is represented by a series of marks 8. The address information is structured in a customary fashion, for example, first a synchronization component after which an address and error detection symbols follow. The position of a read/write head may be checked with this address information, so that information can be written in the desired sector.

Fig. 2 diagrammatically shows an embodiment of reference patterns 2 in several parallel tracks of a land/groove servopattern. The upper track 21 is a groove which is continued as groove 26 after the sectorheader 20 of the reference pattern. The second track 22 is a land and is continued after a sectorheader as a land 27. At least at one reference

pattern per winding the land/groove will be alternated at a sectorheader, in that event the upper groove 21 is continued as a land 26 and the second track 22 is continued as a groove. The reference pattern at an alternation must therefore be aligned in adjacent tracks, further reference patterns per winding need not be aligned. The information in the reference pattern may be written in fields whose center is shifted relative to the middle of the track 9. In the case of shifted fields a less strong reading signal will be available, but this is still sufficient for recovering the address information written in the fields. In the case of aligned patterns, a 50% shift of the track pitch 28 can be utilized to advantage. A clearly different reading signal will then develop compared to non-shifted patterns and the shifted fields are equally well readable from the two adjacent tracks. The reference pattern shown in Fig. 2 is formed by 2 fields 23 shifted upwards, two fields 24 shifted downwards and an unwritten area 25. In the case of non-aligned reference patterns, a smaller shift or no shift at all should be used. According to the invention, auxiliary information is included in the reference patterns, for example, one of the shifted fields 23 or 24 may be used as auxiliary information. The auxiliary information is then represented by optically readable marks in like manner to which the information is represented in the sectors. The information is represented, for example, by the position and/or length of the marks like for the CD. Since the auxiliary information is represented in the same manner, both the information and the auxiliary information can be recovered by the same demodulator. The auxiliary information may contain, for example, a decoding key, a serial number, or access codes. In an embodiment, wherein address information is written successively or recurrently in the reference patterns, one of the recurrences may then be replaced by auxiliary information. In an embodiment of the information carrier according to the invention, the auxiliary information contains check information necessary for the use of the information. The check information is coupled to the ultimate function of the information in the intended application. This is advantageous in that the information reproduction and processing can be checked by the user in the device suitable for this purpose, since the check function of the information can only be realized in this device. For example, in the case of compressed video information, decompressing and reconstructing the video signal is the final function of the information. By coupling the check information to at least one of these functions, a proper protection against illegal copying is possible. Indeed, in that case there is no simple link between the auxiliary information and the other information. This is contrary to prior-art systems, such as, for example, a copy bit which denotes that the information must not be copied and is written on a fixed position on the information carrier, because in that case illegal modification is simple. In another



embodiment, the information comprises a computer program and additional information is necessary when this program is run in the computer. During operation, the program then calls additional information when certain functions are executed. The check information is highly suitable as additional information. The computer program may then be installed on a computer system (on the hard disk), it is true, but for running the program (or parts thereof), the original information carrier is to be present.

A system for controlled reproduction of information according to the invention comprises an information carrier of the read-only type which contains information and reference patterns comprising auxiliary information, and a reading device. This read-only information carrier may be produced in a customary fashion, for example pressed like a CD, during which production the auxiliary information is included in the reference patterns. An information carrier of the read-only type according to the invention comprises the auxiliary information included in the reference patterns. This is an advantage, because on playback, this information is not freely available on the output of the device and is therefore not readily available for copying. If, for example, a video CD is read on a PC through a CD-ROM player, the auxiliary information is not accessible to the PC. In addition, there are information carriers of a writable type and devices for writing them, which information carriers, after being written, can basically be played back in a reading device, because information is written in similar manner, such as, for example, a CD-WO (Write Once).

Such a writing device is generally not capable of writing arbitrary reference patterns. In an embodiment of a writable information carrier according to the invention, the reference patterns are not erasable. Such reference patterns may be produced by the manufacturer of a blank writable type of information carrier. This is advantageous in that, although a writing device may be capable of writing any arbitrary pattern, there is still no possibility of erasing the reference patterns and introducing them anew including the auxiliary information. An embodiment is an information carrier which comprises a pick-up layer of phase-change material and reference patterns via embossing. Another embodiment is an information carrier which comprises a write once pick-up layer in which reference patterns are already written on manufacturing. In another embodiment of the information carrier, the reference patterns containing the auxiliary information deviate from the further reference patterns, whereas a standard writing device cannot produce this deviation. A first example of deviation is that (some) reference patterns are shifted transversely to the track as described above. In another example, in a system in which rotation of the information carrier during reading and writing is controlled in a standard fashion at a Constant Linear Velocity (CLV), reference patterns

on the information carrier are written in a Constant Angular Velocity (CAV) mode. In CLV mode, the disk rotation speed is adapted, so that the speed of the track relative to the recording position is constant, whereas in CAV the rotation speed is constant. In the case where a standard CLV writing device is capable of writing reference patterns, this device  
5 will still not be capable of writing CAV patterns as the rotation speed is controlled in CLV mode. An embodiment of the information carrier comprises said deviating reference patterns in a predetermined part of the track only. This predetermined part may be a lead-in or lead-out area, or a specific annularly shaped portion of the writable area on the information carrier. The reference patterns in this part comprising the auxiliary information will be read  
10 by a reading device according to the invention, while undisturbed reading of information in the further track by a standard reading device is possible. The part of the track not comprising reference patterns may be formatted differently, e.g. according to an existing information recording standard, such as DVD-ROM. If CAV mode reference patterns are used, the position of the reference patterns is known in adjacent windings. To detect illegal  
15 copies, the reading device should check whether the patterns are written in CAV mode, e.g. if they are positioned, as required, from track to track by skipping a few tracks and comparing the timing of the reference patterns in relation to the timing of the rotation of the information carrier. If shifted transversely, reference patterns are used, CAV reference patterns should be exactly aligned from winding to winding of the track. This is important  
20 for reliably reading a shifted pattern or adjacent main data, as non-aligned shifted patterns would cause radial crosstalk when read. To detect illegal copies, a reading device according to the invention checks the transverse shifting of the patterns, e.g. by analysing signals of subdetectors, to detect differences in reflected radiation caused by shifted patterns compared to non-shifted patterns. As a result of the need to write the reference patterns comprising the  
25 auxiliary information and deviating from standard reference patterns, generating an illegal copy on a standard writing device will be impossible. As an example, a write-once system according to the CD standard, which is known as CD-R, is able to record any desired information in blocks in CLV mode anywhere on a writable CD, including headers and synchronisation information as prescribed by the CD standards. However a CD-R writer  
30 cannot operate in CAV mode, as the speed of rotation and the location of recording the information blocks is determined by the pregroove servopattern. Therefore, a CD-R writer cannot align reference patterns, i.e. headers, in adjacent tracks. In addition, a CD-R writer cannot write any transversely shifted pattern. An embodiment of the information carrier of a writable type having such shifted reference patterns also comprises user data in a format as

defined in a standard for Read-Only discs, a so called partial ROM disc. The writable format might comprise rules for this ROM part. Usually, the ROM part will comprise non-shifted reference patterns - like headers in groove-only ROM standards - in the usual track formed by pits.

5                    Fig. 3 shows a device according to the invention for reading the disc-shaped information carrier 1. The device comprises a reading unit 31 for reading information blocks from the information carrier 1. The reading unit 31 scans the track 9 by a radiation beam 30. During the scanning operation, the reading unit 31 is positioned over the track 9 by a servosystem of a customary type (not shown). The information carrier 1 rotates, driven by  
10 driving means, while the reading unit 31 reads the track 9 by the beam 30 and converts the optically readable marks representing the information into an electric signal. The device further includes a demodulation means 32 for recovering the information. According to the invention, the auxiliary information is included in the reference patterns and the demodulation means 32 recovers information and auxiliary information in the same manner.  
15 The demodulation means 32 is arranged for distinguishing the type of information read out: information blocks, address information and auxiliary information. The information blocks are presented on the output 33 monitored by a system controller of a customary type (not shown). The address information is applied to the system controller for positioning the reading unit 31. The auxiliary information may be applied to the system controller and used  
20 for releasing the information blocks. For example, the system controller can check the auxiliary information based on predefined check numbers or check information can be derived from the information blocks. If there is no match, the output 33 will be blocked. In another embodiment of the device, the auxiliary information is also presented on the output 33 and is available to the user.

25                    Fig. 4 shows a device according to the invention for reading the disc-shaped information carrier 1 and processing the information. The device corresponds to the device described above with reference to Fig. 3 including a reading unit 31 and a demodulation means 32 for recovering the information. According to the invention, the device comprises a processor 43 for processing the information and a processor means 44 for  
30 processing the auxiliary information, the two being coupled to the demodulation means 32. In a first embodiment, the processing means 44 is arranged for information block decoding for which a decoding key is derived from the auxiliary information by the processing means 44. The processor 43 is then arranged for descrambling or decrypting the information blocks in dependence on the decoding key. In a second embodiment, the processor 43 is arranged for

executing a function of the information, for example, if the information blocks contain compressed MPEG2 video information, the recovery of the video signal. The auxiliary information contains check information necessary for the recovery. Without the auxiliary information, the video signal cannot be reconstructed. No auxiliary information or different auxiliary information is present on an illegal copy of the information carrier, so that the video signal cannot be reconstructed. In another embodiment, the video signal contains a so-called 'watermark' which marks a video signal. Video programs preferably have ever different watermarks for their identification, possibly including manufacturer or time of creation. The watermark may also be formed by specific compression parameter combinations which do not occur in video signals without a watermark. Such a watermark can be simply introduced upon encoding, but is well-nigh impossible to be added or changed later on in a video signal already compressed. The processor 43 is arranged for establishing a watermark in the video signal and, if available, checking the watermark against check information derived from the auxiliary information. Illegally copied video information can be blocked if there is no match between the check information and the watermark. It is then an advantage that the detection of the watermark and the matching against the check information takes place directly upon reading. The watermark is preferably detectable without decompressing the video information completely, so that the processor 43 may be of a simpler type.

Fig. 5 shows a device according to the invention for reading the disc-shaped information carrier 1 and processing the information. The device corresponding to the device described above with reference to Fig. 4 comprises a reading unit 31, a demodulation means 32 for recovering the information, a processor 43 for processing the information and a processing means 44 for processing the auxiliary information. The device further comprises a processing unit 50 for processing computer programs, which unit is coupled to the output of the processor 43 and to the system controller (not shown) via an interface. The information carrier contains a computer program in which a number of essential data are included just in the auxiliary information. They may be, for example, a decoding key, a serial number or access code or, possibly, a small part of the program code (a subroutine, object or module). Needing these essential data, the program can only function well if both the information blocks and the auxiliary information are available. In another embodiment, the processor 43 is arranged for selectively transferring part of the auxiliary information to the user. This is attractive, for example, when information reproduction is used in a computer system. Not transferring all the auxiliary information to the user provides a better protection of the

information. When an illegal copy is then manufactured, it is impossible with a search routine to call all the auxiliary information of the information carrier and produce an auxiliary file on the illegal copy, by which file the auxiliary information can be rendered available when the illegal copy is used in a system. The part of the auxiliary information that  
5 can be transferred freely can relate, for example, to a fixed part of the information carrier or be included in the auxiliary information itself. The information comprises a computer program and the auxiliary information comprises codes which are fetched by the computer program at arbitrary instants during execution. If no codes or incorrect codes are reproduced when fetched, because an illegal copy of the software is used, the program will stop and thus  
10 be rendered useless.

The invention may also be applied to non-disc shaped information carriers, such as optical tapes or optical cards, which contain a servopattern of reference patterns. Alternatively, the invention may be applied to magnetic and other information carriers, provided they contain a servopattern of reference patterns in which auxiliary  
15 information can be accommodated in the reference patterns.

CLAIMS:

1. An information carrier which comprises a track for writing patterns which represent information in a predefined manner and for writing related auxiliary information, characterized in that the information carrier comprises reference patterns which divide the track into areas for writing the information in blocks, which reference patterns represent the auxiliary information in the predefined manner.
2. An information carrier as claimed in Claim 1, characterized in that the auxiliary information comprises check information related to a function of the information, which check information is to be applied when the information is processed for the function to be executed.
3. An information carrier as claimed in Claim 2, characterized in that the information comprises video information, which video information contains a check code, and the video information processing is dependent on the check code and the check information.
4. An information carrier as claimed in Claim 2, characterized in that the information comprises a computer program for which the running of the computer program depends on the check information.
5. An information carrier as claimed in Claim 1, characterized in that the information carrier is of an optically readable type in which the predefined manner comprises representing a binary information signal by optically readable patterns.
6. An information carrier as claimed in Claim 1 or 5, characterized in that the information carrier is of a writable type on which the information can be written by a writing process, while the reference patterns are non-erasable.
7. An information carrier as claimed in Claim 1 or 5, characterized in that the reference patterns comprise marks whose center is shifted relative to the middle of the track.
8. An information carrier as claimed in Claim 1 or 5, characterized in that the reference patterns are present only in a predetermined part of the track.
9. An information carrier as claimed in Claim 1, 5 or 8, characterized in that the reference patterns are aligned in adjacent windings of the track.

10. A reading device for reproducing information from an information carrier, the information carrier comprising a track for writing patterns which represent information in a predefined manner and for writing related auxiliary information, the device comprising reading means for reading the patterns, and a demodulation means for recovering the information from the read signal in a predefined manner, and means for recovering the auxiliary information, characterized in that the demodulation means comprises means for recovering the auxiliary information from reference patterns present on the information carrier, which reference patterns divide the track into areas for writing the information in blocks.
- 10 11. A reading device as claimed in Claim 10, characterized in that the device comprises means for information processing and/or auxiliary information processing in dependence on the auxiliary information.
12. A reading device as claimed in Claim 11, characterized in that the auxiliary information comprises check information related to a function of the information, and in that the information processing means are arranged for executing the function in dependence on the check information.
- 15 13. A reading device as claimed in Claim 11, characterized in that the information comprises video information which contains a check code, and in that the information processing means are arranged for processing the video information in dependence on the check code and the check information.
- 20 14. A reading device as claimed in Claim 11, characterized in that the information comprises a computer program, and in that the information processing means are arranged for running the computer program in dependence on the check information.
- 25 15. A reading device as claimed in Claim 11 or 12, characterized in that the information comprises a computer program, and in that the means for processing the auxiliary information are arranged for transferring the auxiliary information to the computer program while a predefined part of the auxiliary information is blocked.
16. A reading device as claimed in Claim 10, characterized in that the device comprises means for detecting the position of the reference patterns relative to the track or other reference patterns.
- 30 17. A method of manufacturing an information carrier which comprises a track for writing patterns which represent information in a predefined manner and for writing related auxiliary information, the auxiliary information being determined in dependence on the information, characterized in that the information carrier is provided with reference

patterns which divide the track into areas for writing the information in blocks, while the reference patterns represent the auxiliary information in the predefined manner.



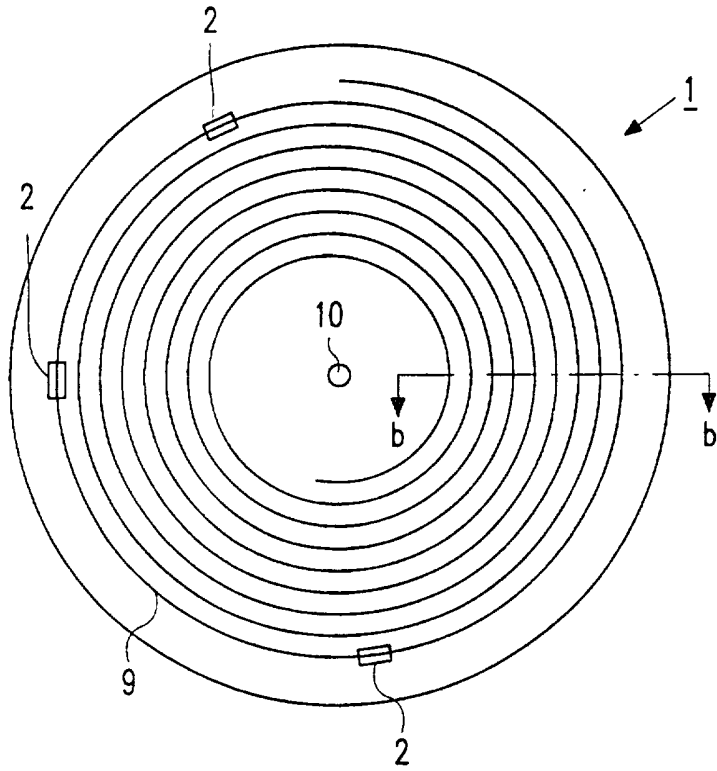

FIG. 1a

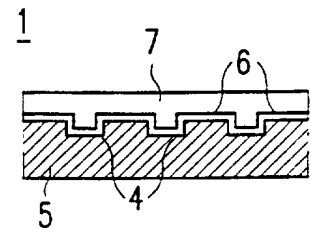

FIG. 1b

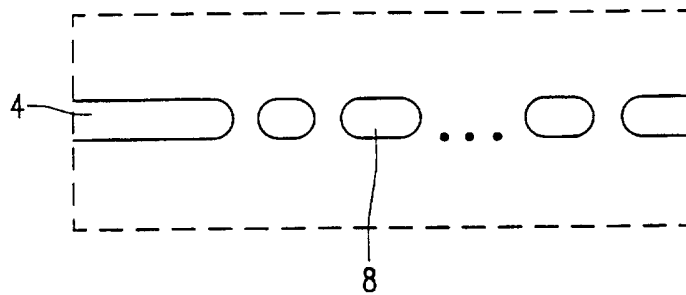

FIG. 1c

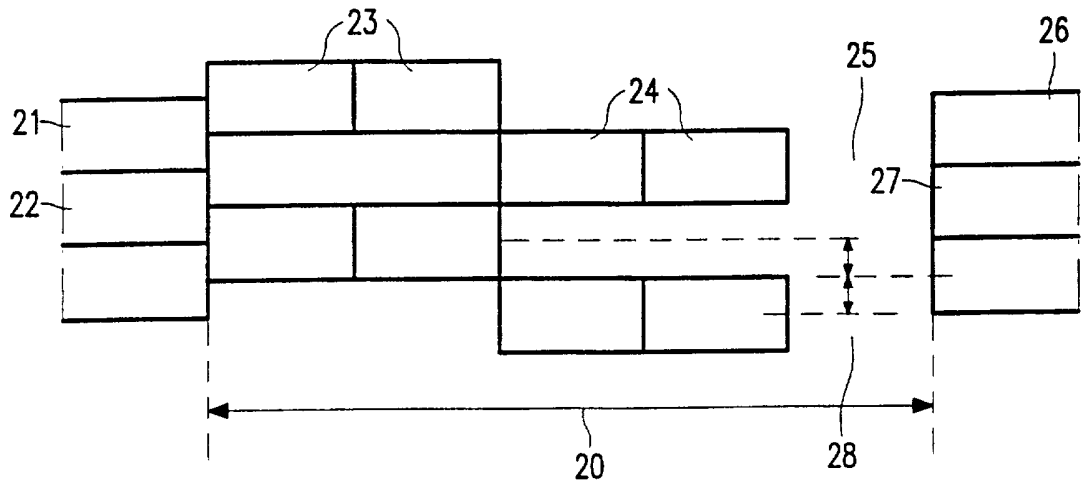

FIG. 2

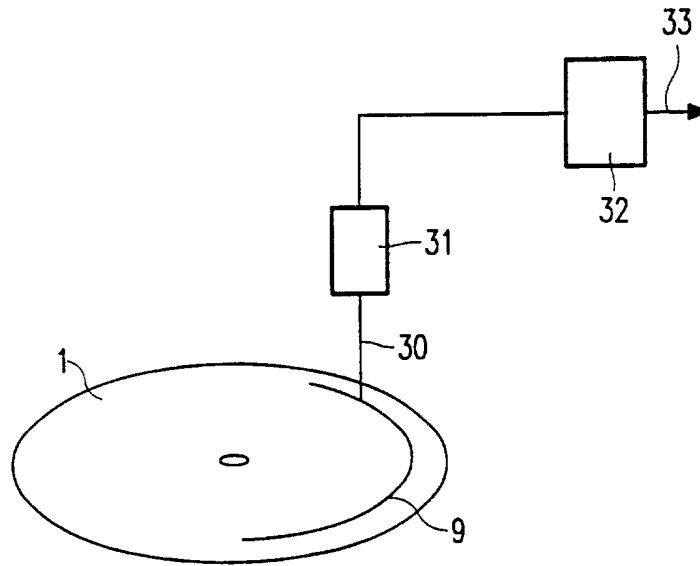

FIG. 3

3/3

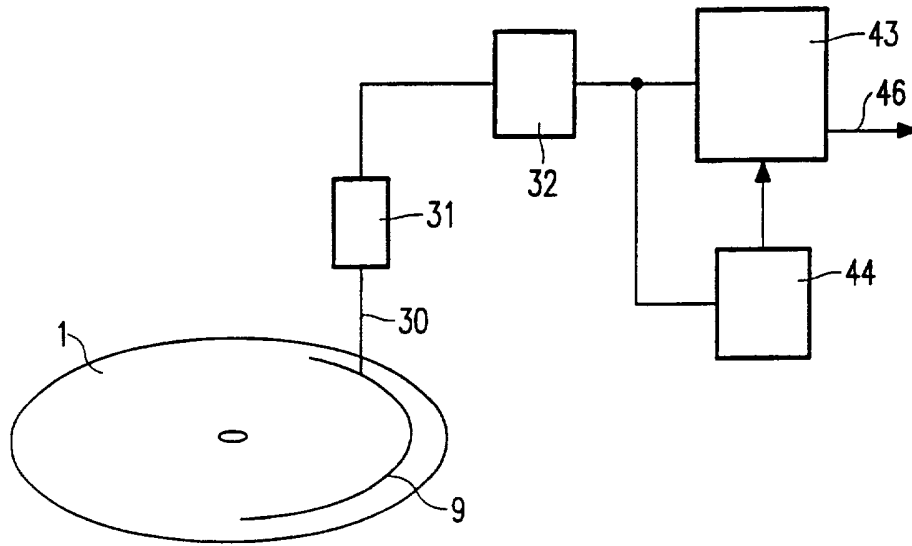

FIG. 4

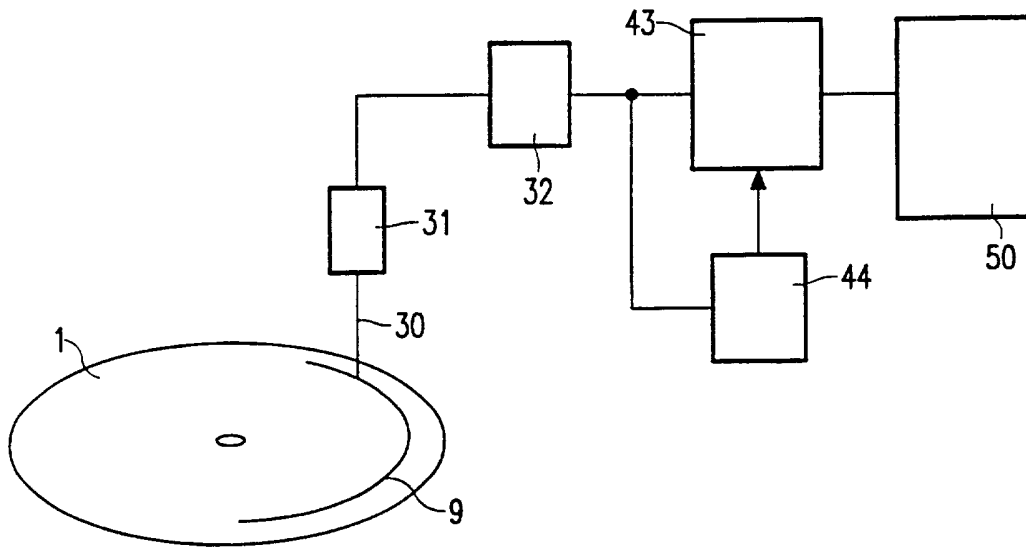

FIG. 5

## INTERNATIONAL SEARCH REPORT

International application No.  
PCT/IB 97/00660

## A. CLASSIFICATION OF SUBJECT MATTER

IPC6: G11B 7/007, G11B 27/36  
According to International Patent Classification (IPC) or to both national classification and IPC

## B. FIELDS SEARCHED

Minimum documentation searched (classification system followed by classification symbols)

IPC6: G11B

Documentation searched other than minimum documentation to the extent that such documents are included in the fields searched

SE,DK,FI,NO classes as above

Electronic data base consulted during the international search (name of data base and, where practicable, search terms used)

EPAT, WPI, JAPIO

## C. DOCUMENTS CONSIDERED TO BE RELEVANT

Category*	Citation of document, with indication, where appropriate, of the relevant passages	Relevant to claim No.
X	US 5253131 A (CHEVALIER), 12 October 1993 (12.10.93), column 4, line 4 - line 51, abstract	1-2,6,8-11, 16-17
A	--	3-5,7,12-15
X	US 5321675 A (ITO ET AL), 14 June 1994 (14.06.94), column 6, line 1 - line 15, abstract	1-2,5-11, 16-17
A	--	3-4,12-15

Further documents are listed in the continuation of Box C.

See patent family annex.

\* Special categories of cited documents:

- "A" document defining the general state of the art which is not considered to be of particular relevance  
 "E" earlier document but published on or after the international filing date  
 "L" document which may throw doubts on priority claim(s) or which is cited to establish the publication date of another citation or other special reason (as specified)  
 "O" document referring to an oral disclosure, use, exhibition or other means  
 "P" document published prior to the international filing date but later than the priority date claimed

- "T" later document published after the international filing date or priority date and not in conflict with the application but cited to understand the principle or theory underlying the invention  
 "X" document of particular relevance: the claimed invention cannot be considered novel or cannot be considered to involve an inventive step when the document is taken alone  
 "Y" document of particular relevance: the claimed invention cannot be considered to involve an inventive step when the document is combined with one or more other such documents, such combination being obvious to a person skilled in the art  
 "&" document member of the same patent family

Date of the actual completion of the international search

2 December 1997

Date of mailing of the international search report

04.12.97

Name and mailing address of the ISA/  
Swedish Patent Office  
Box 5055, S-102 42 STOCKHOLM  
Facsimile No. +46 8 666 02 86

Authorized officer

Benny Andersson  
Telephone No. +46 8 782 25 00

## INTERNATIONAL SEARCH REPORT

International application No.

PCT/IB 97/00660

C (Continuation). DOCUMENTS CONSIDERED TO BE RELEVANT		
Category*	Citation of document, with indication, where appropriate, of the relevant passages	Relevant to claim No.
X	EP 0522750 A2 (INTERNATIONAL BUSINESS MACHINES CORPORATION), 13 January 1993 (13.01.93), column 7, line 6 - line 38, abstract	1-2,5-11, 16-17
A	--	3-4,12-15
X	US 5452285 A (MONEN), 19 Sept 1995 (19.09.95), column 4, line 39 - line 57; column 6, line 18 - line 37	1-2,5-11, 16-17
A	--	3-4,12-15
X	EP 0397238 A1 (N.V. PHILIPS' GLOEILAMPENFABRIEKEN), 14 November 1990 (14.11.90), figure 1, abstract	1-2,5-11, 16-17
A	--	3-4,12-15
X	EP 0545472 A1 (N.V. PHILIPS' GLOEILAMPENFABRIEKEN), 9 June 1993 (09.06.93), abstract	1-2,5-11, 16-17
A	-- -----	3-4,12-15

**INTERNATIONAL SEARCH REPORT**  
Information on patent family members

01/10/97

International application No.  
PCT/IB 97/00660

Patent document cited in search report	Publication date	Patent family member(s)	Publication date
US 5253131 A	12/10/93	NONE	
US 5321675 A	14/06/94	JP 1223635 A JP 1243240 A JP 1243241 A JP 2606265 B	06/09/89 27/09/89 27/09/89 30/04/97
EP 0522750 A2	13/01/93	JP 5174498 A US 5438559 A US 5500848 A US 5615190 A	13/07/93 01/08/95 19/03/96 25/03/97
US 5452285 A	19/09/95	NONE	
EP 0397238 A1	14/11/90	SE 0397238 T3 AT 130695 T AU 640646 B AU 5471890 A CA 2016055 A CN 1024603 B CN 1047159 A DE 69023692 D,T ES 2080783 T HK 169696 A JP 3003168 A US 5418764 A US 5654947 A	15/12/95 02/09/93 08/11/90 08/11/90 18/05/94 21/11/90 27/06/96 16/02/96 20/09/96 09/01/91 23/05/95 05/08/97
EP 0545472 A1	09/06/93	JP 5325193 A	10/12/93