



US008878373B2

(12) **United States Patent**
Thoresen

(10) **Patent No.:** **US 8,878,373 B2**
(45) **Date of Patent:** **Nov. 4, 2014**

(54) **VARIABLE ELECTRICAL GENERATOR**

(75) Inventor: **Kent Thoresen**, Drammen (NO)

(73) Assignee: **Adaptive Generators AS**, Drammen (NO)

(*) Notice: Subject to any disclaimer, the term of this patent is extended or adjusted under 35 U.S.C. 154(b) by 0 days.

(21) Appl. No.: **13/636,575**

(22) PCT Filed: **Mar. 23, 2011**

(86) PCT No.: **PCT/NO2011/000099**

§ 371 (c)(1),
(2), (4) Date: **Nov. 26, 2012**

(87) PCT Pub. No.: **WO2011/119042**

PCT Pub. Date: **Sep. 29, 2011**

(65) **Prior Publication Data**

US 2013/0062889 A1 Mar. 14, 2013

(30) **Foreign Application Priority Data**

Mar. 23, 2010 (NO) 20100443

(51) **Int. Cl.**
F02B 63/04 (2006.01)
F03G 7/08 (2006.01)

(Continued)

(52) **U.S. Cl.**
CPC **H02P 25/22** (2013.01); **F05B 2220/7064**
(2013.01); **H02P 27/16** (2013.01);

(Continued)

(58) **Field of Classification Search**
USPC 310/46, 112, 156, 216, 268; 322/89;
290/1 R

See application file for complete search history.

(56) **References Cited**

U.S. PATENT DOCUMENTS

1,863,294 A * 6/1932 Bogia 310/46
2,993,159 A * 7/1961 Devol 318/400.39

(Continued)

FOREIGN PATENT DOCUMENTS

DE 102007054719 A1 1/2009
EP 0772735 A1 2/1996

(Continued)

OTHER PUBLICATIONS

International Search Report of parent Application No. PCT/2011/000099, 4 pages (dated Jul. 5, 2012).

Primary Examiner — Pedro J Cuevas

(74) *Attorney, Agent, or Firm* — Rothwell, Figg, Ernst & Manbeck PC

(57) **ABSTRACT**

A variable electrical generator (20) is operable to convert mechanical motion to electrical power. The generator (20) includes at least a stator element (60) and a rotor element (50) including coils (320) and magnets (90). The generator (20) includes a configuration of modules (80) including the coils (320) for generating wavelets (30) in response to the coils (320) interacting magnetically with the magnets (90), and a control arrangement (70) for combining the wavelets (30) for generating a composite synthesized power output (10) from the generator (20). A method of maintaining a variable generator (20) includes steps of: (a) determining operating status of modules (80) of the generator (20); (b) unplugging and replacing one or more defective modules (80) as identified in step (a). The generator (20) is susceptible to being used in renewable energy system, for example in a tidal water turbine, in a wind turbine, in association with an oscillating wind vane, in association with an ocean float, in a hydroelectric turbine, in a steam turbine.

15 Claims, 14 Drawing Sheets

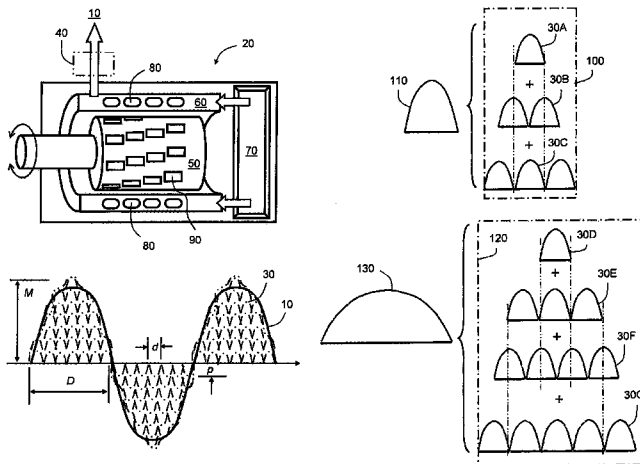

(51) **Int. Cl.**

<i>H02K 7/18</i>	(2006.01)	5,731,649 A *	3/1998	Caamano	310/216.047
<i>H02P 27/16</i>	(2006.01)	5,814,914 A *	9/1998	Caamano	310/216.047
<i>H02K 21/12</i>	(2006.01)	5,903,082 A *	5/1999	Caamano	310/216.001
<i>F03D 9/00</i>	(2006.01)	5,982,070 A *	11/1999	Caamano	310/216.047
<i>H02K 11/00</i>	(2006.01)	5,982,074 A *	11/1999	Smith et al.	310/254.1
<i>H02P 25/22</i>	(2006.01)	5,986,378 A *	11/1999	Caamano	310/216.047
<i>H02K 1/18</i>	(2006.01)	6,049,197 A *	4/2000	Caamano	322/89
<i>F03B 13/12</i>	(2006.01)	6,154,013 A *	11/2000	Caamano	322/89
<i>H02P 9/48</i>	(2006.01)	6,259,233 B1 *	7/2001	Caamano	322/89
<i>H02K 7/20</i>	(2006.01)	6,323,576 B1 *	11/2001	Applegate	310/268
<i>H02K 17/44</i>	(2006.01)	6,407,466 B2 *	6/2002	Caamano	290/52
<i>H02K 21/24</i>	(2006.01)	6,455,969 B1 *	9/2002	Chen	310/114
<i>H02K 21/22</i>	(2006.01)	6,476,511 B1	11/2002	Yemm et al.	
<i>H02P 9/00</i>	(2006.01)	6,486,640 B2 *	11/2002	Adams	322/59
<i>H02K 21/14</i>	(2006.01)	6,605,883 B2 *	8/2003	Isozaki et al.	310/49.42
		6,794,783 B2 *	9/2004	Tu et al.	310/156.32
		6,849,984 B2 *	2/2005	Gallant	310/178
		RE38,939 E *	1/2006	Kessinger et al.	310/268
		7,105,972 B2 *	9/2006	Gallant	318/400.31
		7,525,228 B2 *	4/2009	Chuang et al.	310/112
		7,710,081 B2 *	5/2010	Saban et al.	322/89
		7,777,391 B2 *	8/2010	Asano	310/268
		7,808,142 B2 *	10/2010	Wise	310/156.32
		7,888,839 B2 *	2/2011	Gabrys et al.	310/266
		7,960,948 B2 *	6/2011	Saban et al.	322/89
		8,497,612 B2 *	7/2013	Minowa et al.	310/113
		8,575,806 B2 *	11/2013	Kuo et al.	310/156.36
		8,614,529 B2 *	12/2013	Ritchey	310/78
		8,643,249 B2 *	2/2014	Post	310/309
		2001/0022511 A1 *	9/2001	Adams	322/59
		2002/0047455 A1 *	4/2002	Dhyanchand et al.	310/211
		2005/0127767 A1 *	6/2005	Gallant	310/113
		2006/0022552 A1 *	2/2006	Zhu et al.	310/268
		2008/0079400 A1	4/2008	Lacaze	
		2008/0103632 A1 *	5/2008	Saban et al.	700/286
		2010/0244599 A1 *	9/2010	Saban et al.	310/71
		2010/0253085 A1 *	10/2010	Minowa et al.	290/55
		2014/0049285 A1 *	2/2014	Rodriguez	324/765.01
		2014/0077648 A1 *	3/2014	Brauer et al.	310/152
		2014/0091661 A1 *	4/2014	Ritchey	310/114
		2014/0091663 A1 *	4/2014	Hazeyama et al.	310/156.11
		2014/0139161 A1 *	5/2014	Ueda	318/400.37
		2014/0167708 A1 *	6/2014	Ritchey	322/90

(52) **U.S. Cl.**

CPC *H02K 21/12* (2013.01); *H02K 21/24* (2013.01); *F03D 9/002* (2013.01); *H02K 11/0073* (2013.01); *Y02E 10/38* (2013.01); *H02K 21/22* (2013.01); *H02P 2009/003* (2013.01); *H02K 1/18* (2013.01); *Y02E 10/725* (2013.01); *F03B 13/12* (2013.01); *H02K 21/14* (2013.01); *H02K 2213/12* (2013.01); *H02P 2009/004* (2013.01); *H02P 9/48* (2013.01)

USPC **290/1 R**; 310/112; 310/268; 310/46; 322/89

(56) **References Cited**

U.S. PATENT DOCUMENTS

3,452,229 A *	6/1969	Pimlott, Jr. et al.	310/168
3,832,581 A *	8/1974	Hoffmann et al.	310/46
4,211,945 A *	7/1980	Tawse	310/112
4,358,693 A *	11/1982	Palmer et al.	310/46
4,360,753 A *	11/1982	Shannon	310/93
4,486,675 A *	12/1984	Albert	310/46
4,551,645 A *	11/1985	Takahashi et al.	310/46
4,578,610 A *	3/1986	Kliman et al.	310/156.35
4,605,873 A *	8/1986	Hahn	310/154.06
4,794,293 A *	12/1988	Fujisaki et al.	310/268
5,245,238 A *	9/1993	Lynch et al.	310/116
5,396,140 A *	3/1995	Goldie et al.	310/268
5,619,087 A	4/1997	Sakai	

FOREIGN PATENT DOCUMENTS

GB	2113488 A	8/1983
WO	WO 2007/016120 A2	2/2007

* cited by examiner

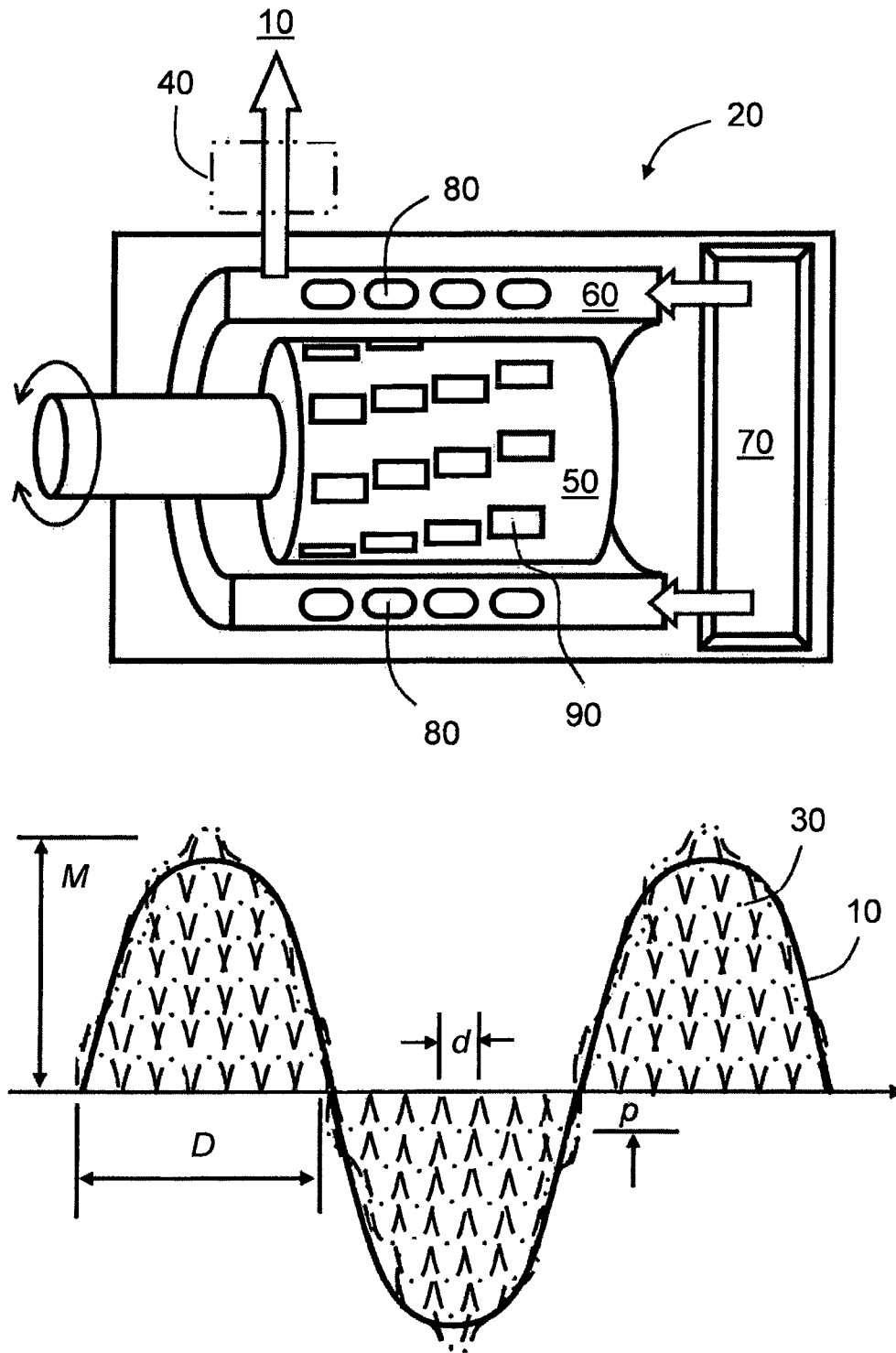

FIG. 1

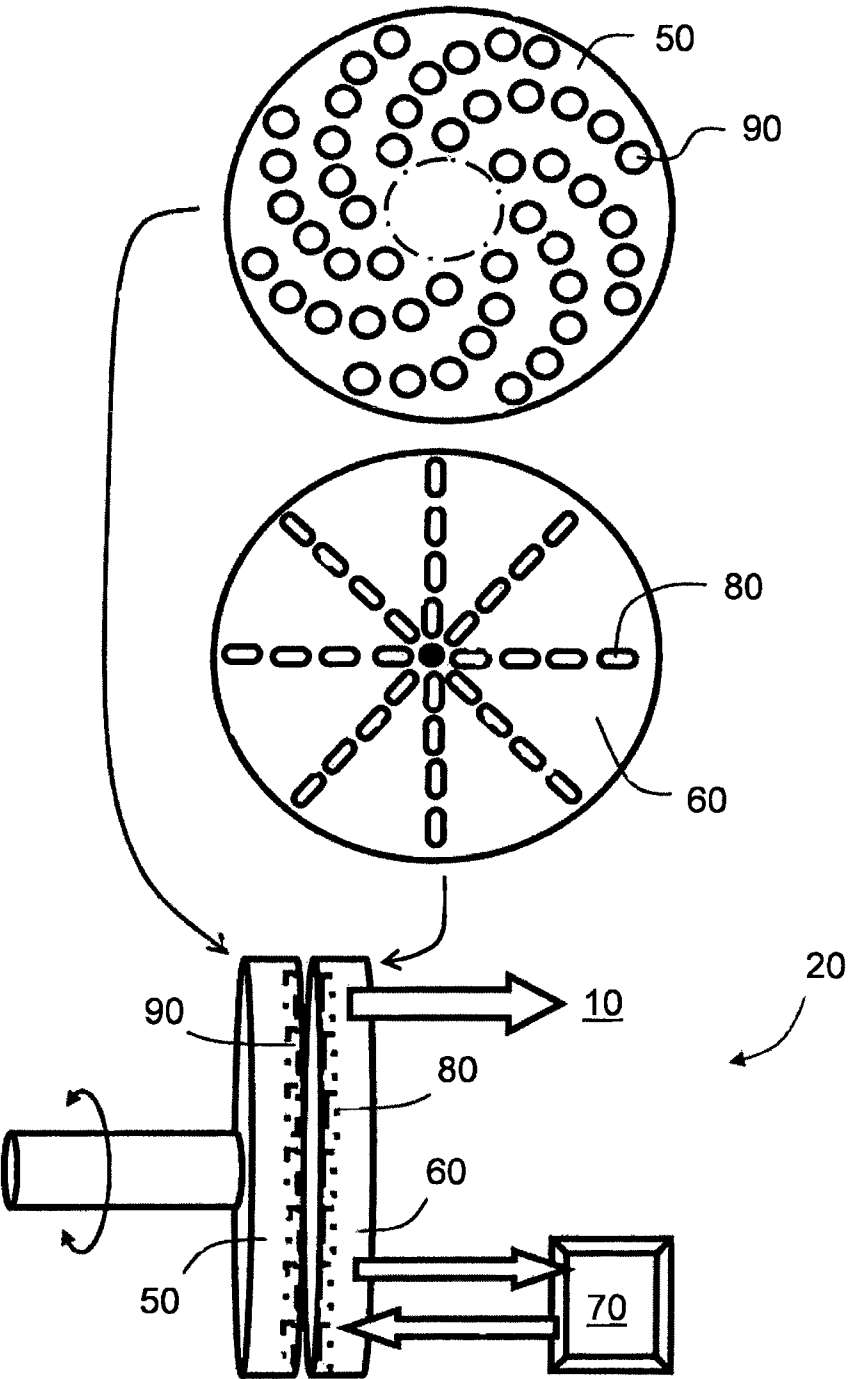

FIG. 2A

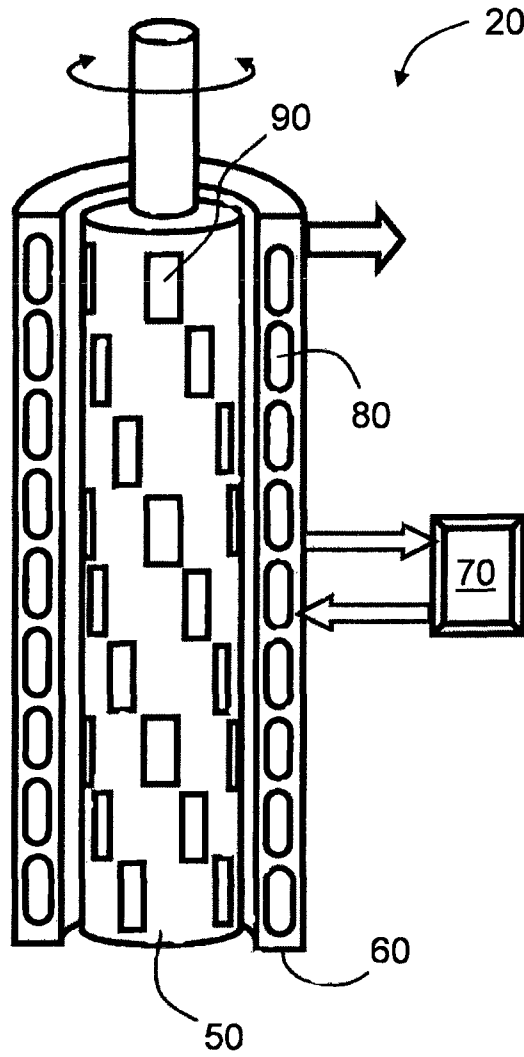

FIG. 2B

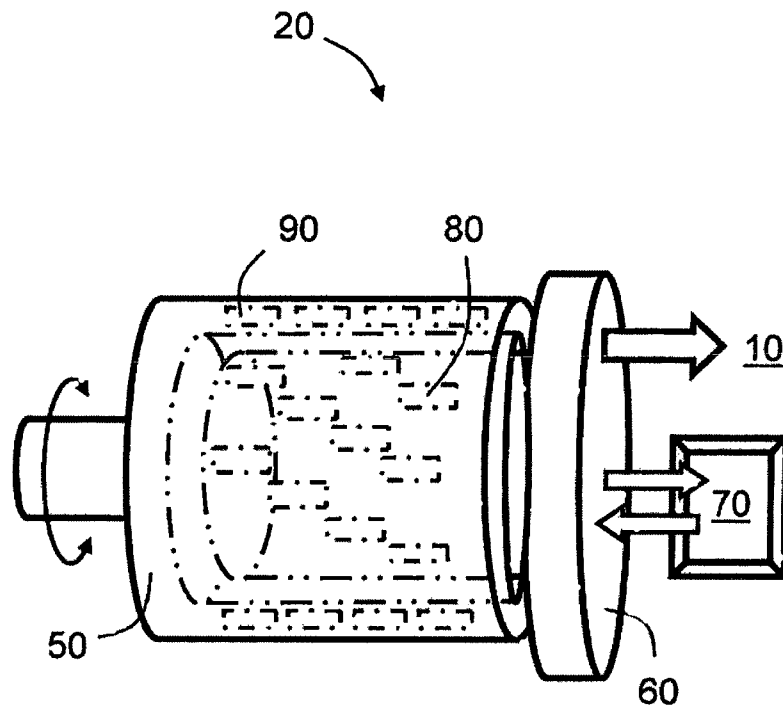

FIG. 2C

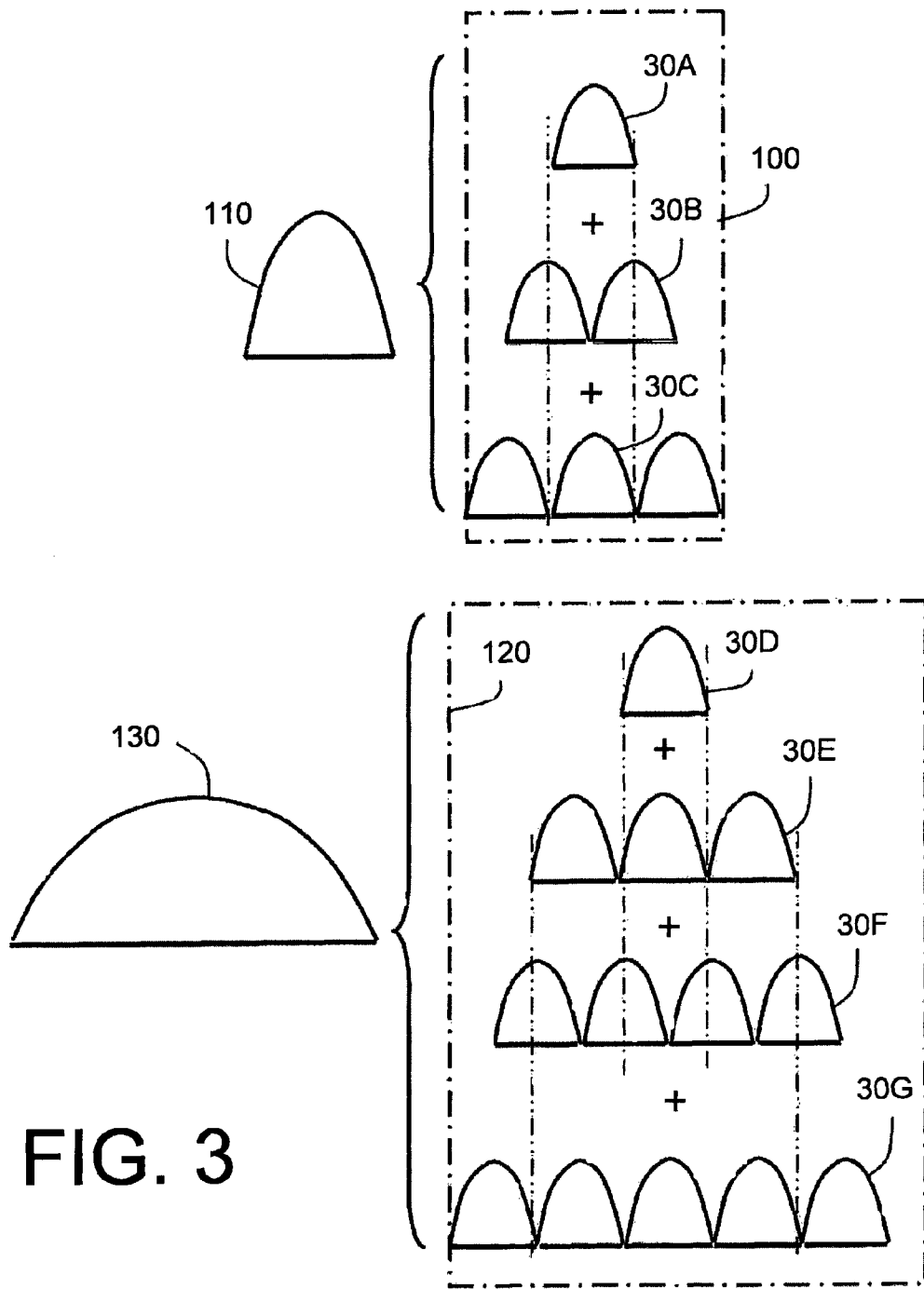

FIG. 3

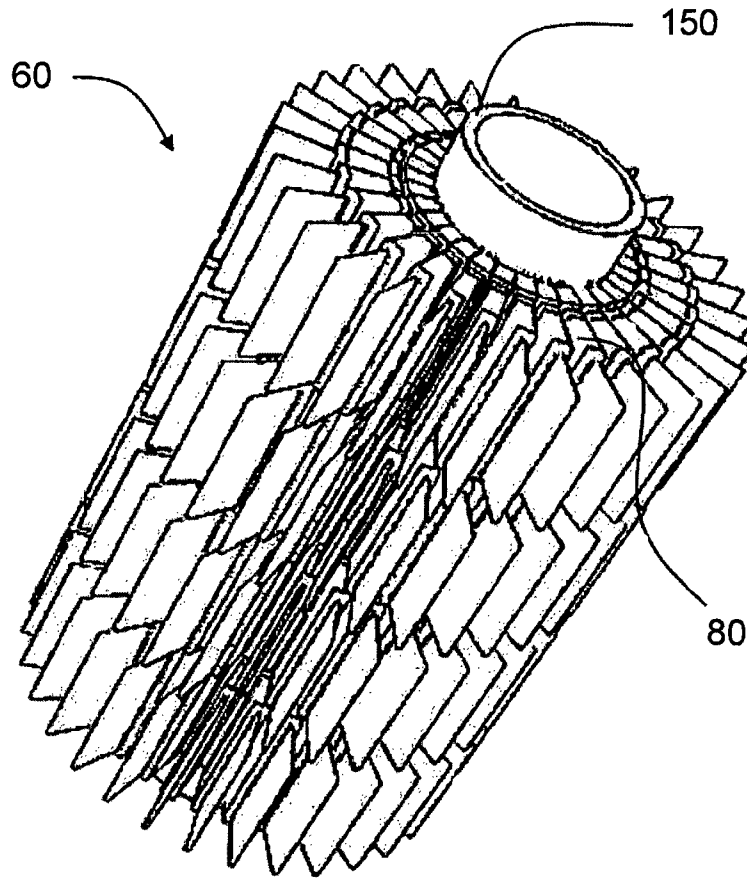

FIG. 4

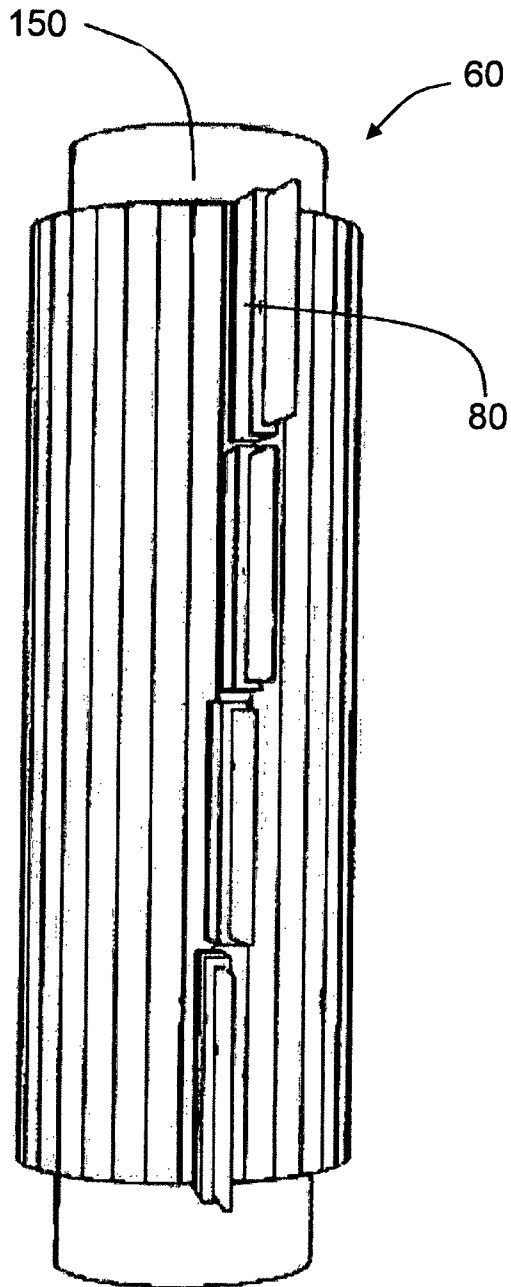

FIG. 5

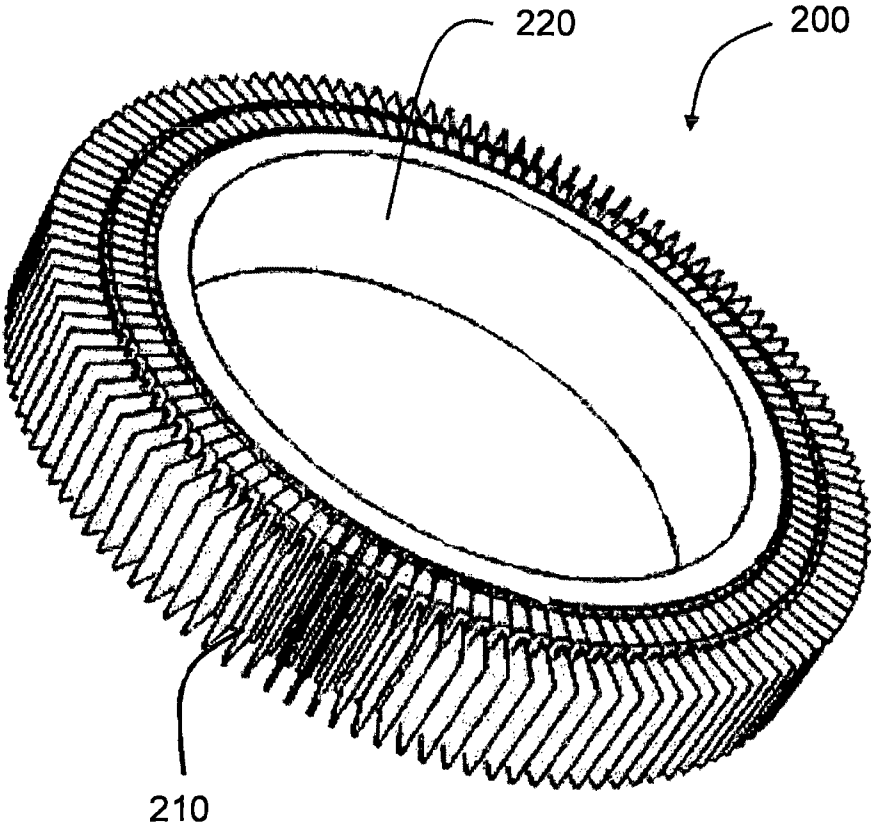

FIG. 6A

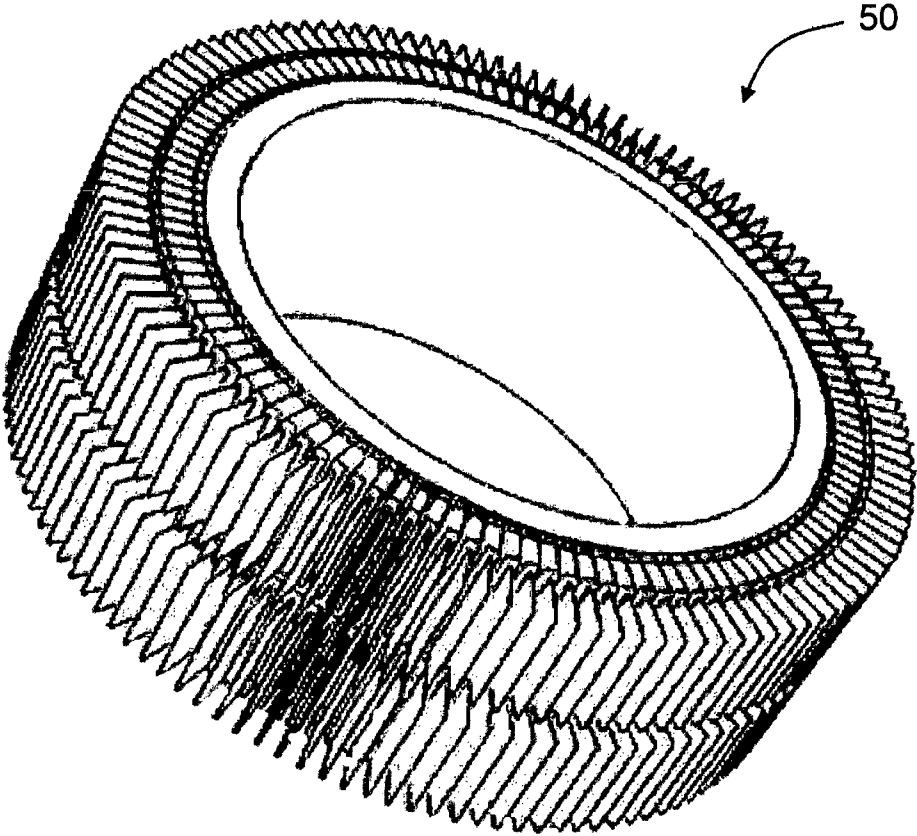

FIG. 6B

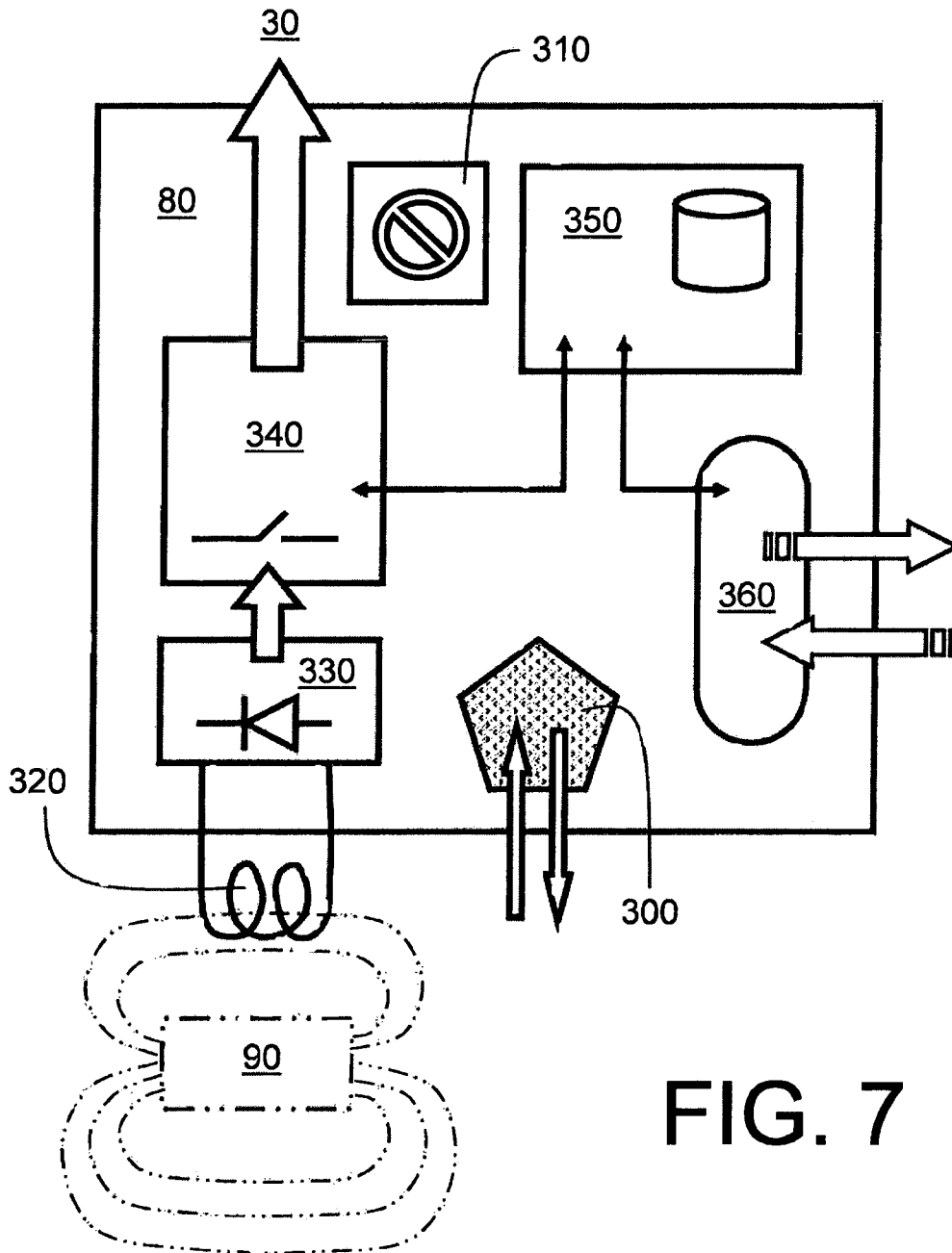

FIG. 7

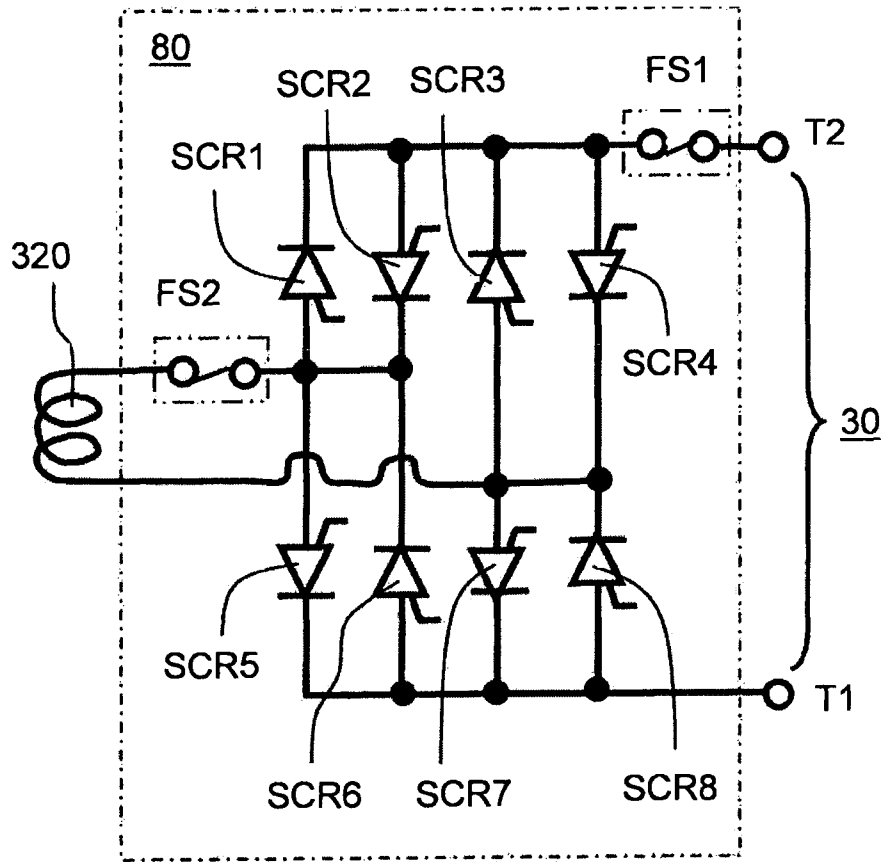

FIG. 8A

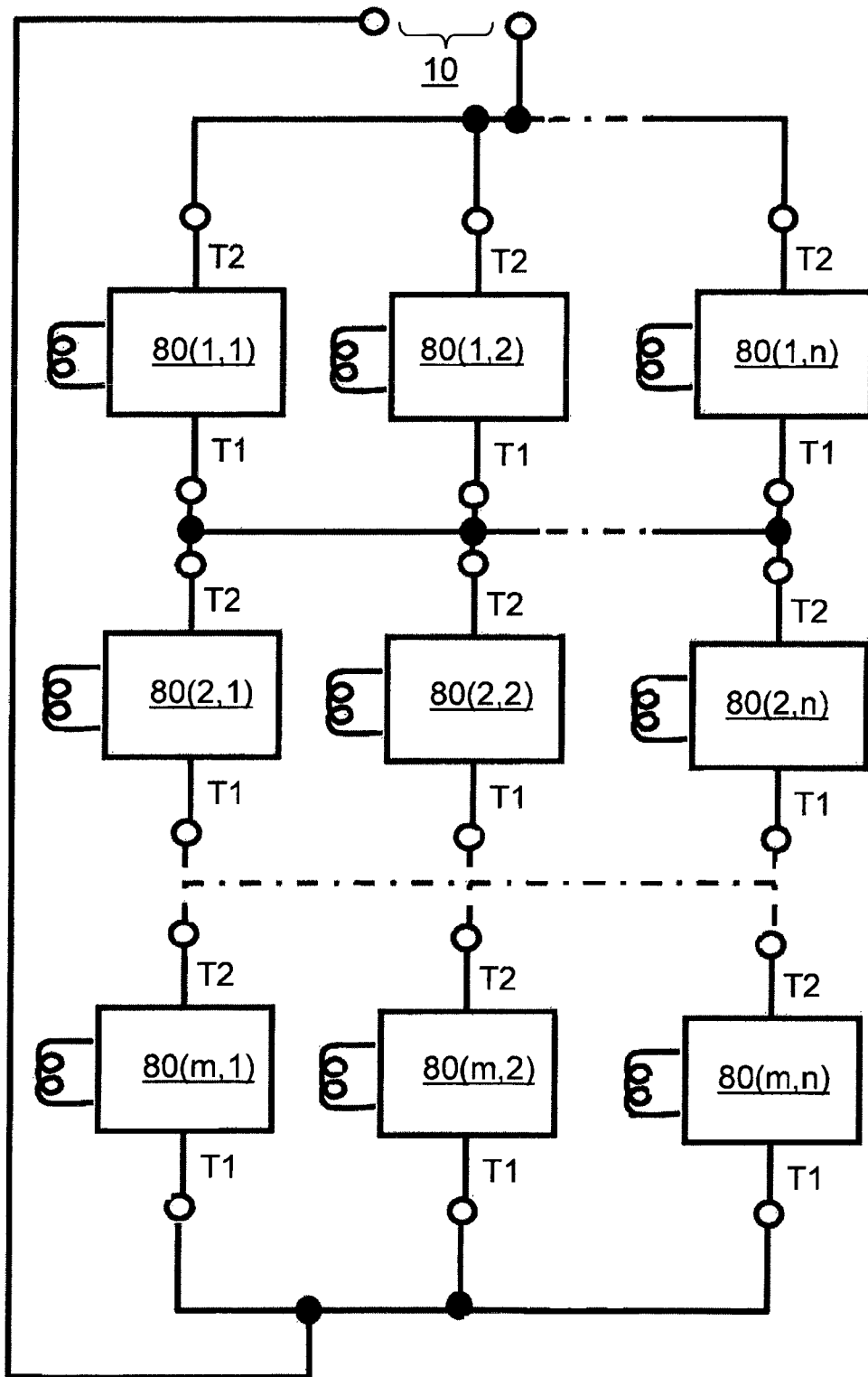

FIG. 8B

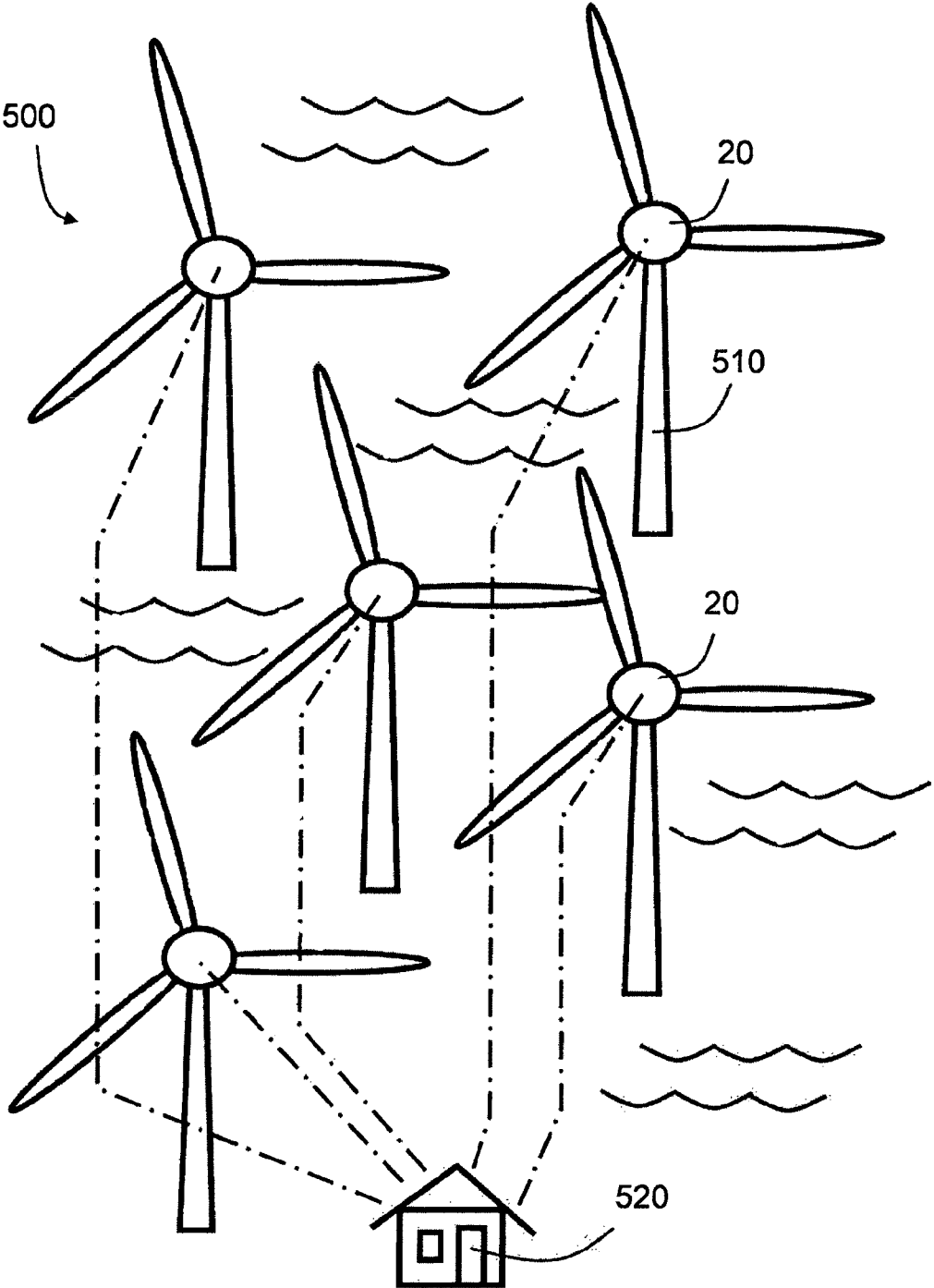
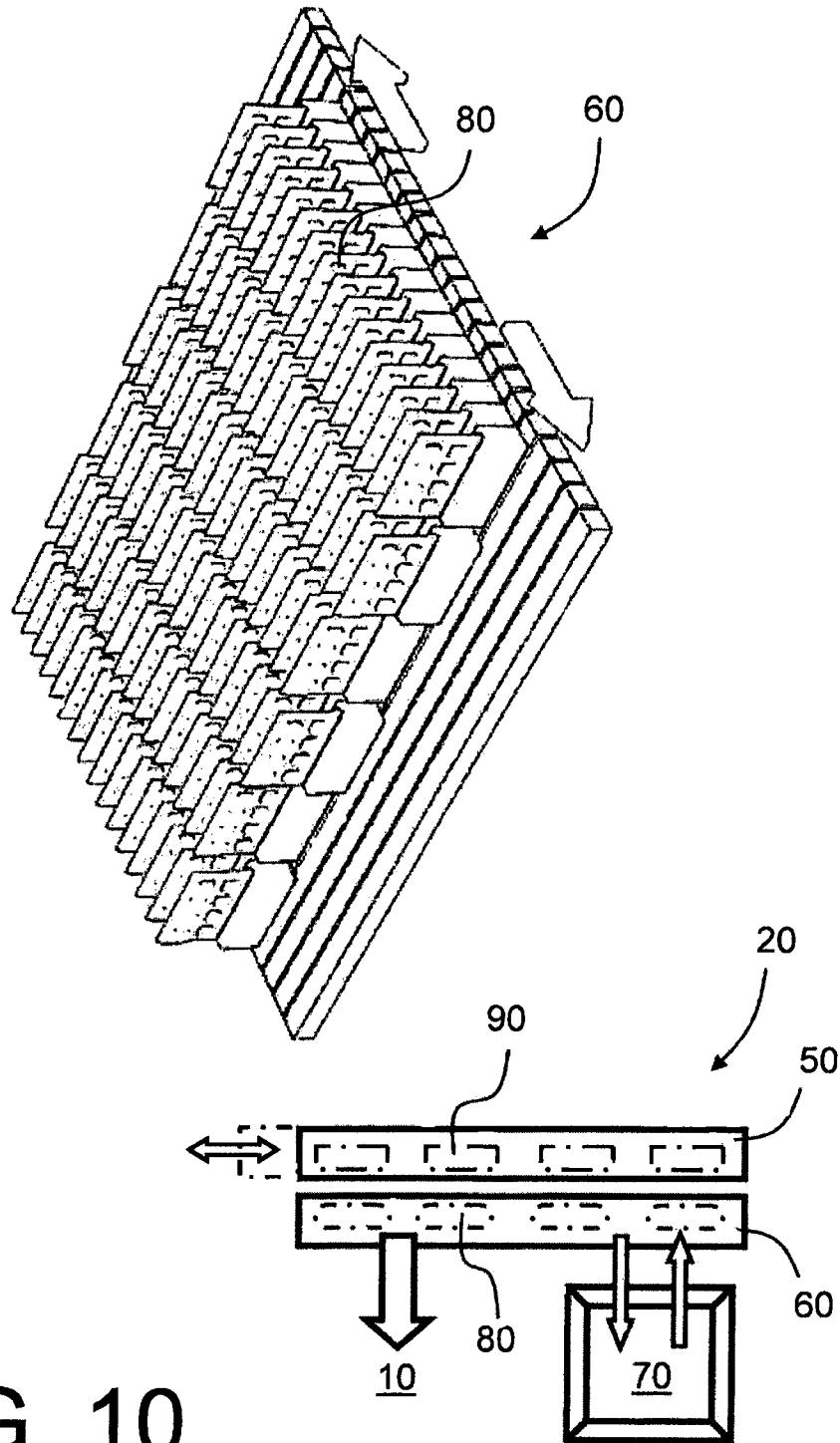

FIG. 9



VARIABLE ELECTRICAL GENERATOR

This application is a 35 U.S.C. 371 National Phase Entry Application from PCT/NO2011/000099, filed Mar. 23, 2011, which claims the benefit of Norwegian Patent Application No. 20100443 filed on Mar. 23, 2010 in the Norwegian Intellectual Property Office, the disclosures of which are incorporated herein in their entirety by reference.

FIELD OF THE INVENTION

The present invention relates to variable electrical generators for converting mechanical rotational and/or displacement energy to electrical energy, for example to a generator which is operable to vary dynamically its electrical output as well as coping with dynamically changing mechanical input rotation and/or reciprocating speeds. Moreover, the present invention also relates to methods of operating these variable electrical generators. Furthermore, the present invention concerns methods of constructing these variable electrical generators. Additionally, the present invention relates to software products executable on computing hardware for implementing methods of the present invention.

BACKGROUND OF THE INVENTION

On account of depletion of fossil fuel reserves, as well as concerns of climate change resulting from anthropogenic activities, attention has been focused in recent years on renewable energy systems. Conventional approaches the electricity generation often involve of form of reservoir, for example a hydroelectric facility includes a water dam providing a steady stream of water which can be regulated via a water valve to drive a turbine, and a hot nuclear reactor core is capable of storing considerable thermal energy for providing a steady stream of steam under high pressure which can be regulated via a steam valve to drive a turbine. In contradistinction, many renewable energy systems driven by wind, tidal flows and ocean wave motion experience a wide range of motion amplitudes, motion velocities, motion frequencies and/or motion directions. Moreover, extreme weather conditions often result in a large dynamic range of motion at various times throughout a year. In consequence, energy pickoff from these renewable energy systems is often technically difficult to implement. A conventional approach to cope with these problems of energy pickoff is to employ hydraulic apparatus, for example hydraulic piston-cylinder pump apparatus as described in U.S. Pat. No. 6,476,511 B1 (Yemm et al.), or hydraulic pump apparatus as described in international PCT patent application WO 2007/016120A2. However, hydraulic systems are prone to wear, and are relatively energy inefficient on account of viscous drag occurring in hydraulic fluids employed therein.

As an alternative to employing hydraulic power pickoff, it is feasible to employ a variable speed generator. Several types of variable speed generators are known, but they are often very rough devices which are not really ideal for applications such as wind power or tidal energy production. Large wind turbines for electricity generation rotate with a fairly low rotation rate (rpm) and current generators designed for use with these turbines utilize either:

- (i) a staged gear system between a wind turbine rotor and a generator, wherein rotational speed is controlled by adjusting wind turbine blade pitch; or
- (ii) a large diameter generator directly coupled to a wind turbine rotor, wherein the generator is designed to operate at low rotation rates.

The output power from the generator is conventionally rectified and then phase formed via power electronics operating at high switching frequencies, for example at frequencies of several kHz. These approaches (i) and (ii) are relatively expensive to implement, especially in respect of electronic apparatus required to rectify and phase form the generated electrical power provided by the generator.

SUMMARY OF THE INVENTION

The present invention seeks to provide a variable electrical generator which is better adapted for coping with variable mechanical input speeds and various input rotation directions and/or linear movement directions.

The present invention seeks to provide an advanced form of variable electrical generator which is more suited to mass production whilst also providing large power generating performance and robust operation.

According to a first aspect of the present invention, there is provided a variable electrical generator as claimed in appended claim 1: there is provided a variable electrical generator for converting mechanical motion to electrical power, wherein the generator includes at least a stator element and a rotor element including coils and magnets, characterized in that the generator includes a configuration of modules including the coils for generating wavelets (30) in response to the coils interacting magnetically with the magnets, and a control arrangement for combining the wavelets for generating a composite synthesized power output from the generator.

The invention is of advantage in that the output can be rapidly dynamically adjusted by controlling a manner in which the wavelets are combined together to synthesize the output.

Optionally, in the generator, the modules are spatially collocated with their corresponding coils to provide power signal metamorphosis at an early stage within the generator. This collocation potentially avoids a need for expensive and complex high-frequency electronic switching units later which are conventionally employed to condition outputs from conventional generators to a form suitable to feed onto an electricity distribution grid. Optionally, the variable electrical generator is beneficially implemented so that the modules are operable to generate wavelets whose duration (d) is shorter than a duration of cycle (D) of an alternating waveform of the output from the generator. Conveniently, when constructing the generator, the stator includes coils and is arranged to remain substantially stationary in operation, and the rotor includes magnets and is arranged to rotate and/or reciprocate in operation relative to the stator to induce wavelet signals in the coils. Optionally, the variable electrical generator is implemented so that the modules are electrically coupled together in a two-dimension switching matrix including at least one series path for adding potentials and at least one parallel path for current preading for generating the output. Optionally, the variable electrical generator is implemented so that the modules are operable to switch between a non-conductive state, a shorted state, a negative wavelet state and a positive wavelet state when in operation in response to control signals provided from the control arrangement. Optionally, the control arrangement is distributed between a control unit external to the modules and microcontrollers present in the modules. Optionally, when implementing the variable electrical generator, the modules are coupled in communication with the control arrangement via an optical data highway. More optionally, when implementing the variable electrical generator, the optical data highway is operable to direct data selectively between the control arrangement and

the modules by way of wavelength division multiplexing (WDM). More optionally, the variable electrical generator is implemented so that the modules are operable to communicate diagnostic signals regarding their operating status to the control arrangement, and to receive control signals from the control arrangement concerning timing information and/or polarity information in respect of their respective wavelets.

Optionally, the variable electrical generator is implemented so that the modules are arranged to be unplugged and plugged into their respective positions on the stator and/or rotor, for example for maintenance and/or repair purposes.

Optionally, the variable electrical generator is implemented so that the modules include solid state switching devices for switching at least half-cycles of induced electrical signals induced within the coils in operation for generating wavelets.

Optionally, the variable electrical generator is implemented so that the control arrangement includes an input for use as a reference when synchronizing and/or adjusting an amplitude and/or phase of the output during operation.

According to a second aspect of the invention, there is provided a module for use in a variable electrical generator pursuant to the first aspect of the invention, wherein the module includes a microcontroller for providing local control of the module, a coil coupled to a switching arrangement for generating wavelets under control of the microcontroller, and an optical communication interface for receiving control data for controlling the module and/or for communicating diagnostic information from the module.

According to a third aspect of the invention, there is provided a method of using a variable electrical generator for converting mechanical motion to electrical power, wherein the generator includes at least a stator element and a rotor element including coils and magnets, characterized in that the method includes:

- (a) generating wavelets in a configuration of modules including the coils for generating wavelets in response to the coils interacting magnetically with the magnets; and
- (b) using a control arrangement to combine the wavelets for generating a composite synthesized power output from the generator.

According to a fourth aspect of the invention, there is provided a renewable energy system for converting linear and/or rotating motion of mechanical apparatus into electrical energy, wherein the apparatus is operable to cause relative movement between a rotor and a stator of a variable generator pursuant to the first aspect of the invention for generating a power output from the system. Optionally, operation of the system is determined by diagnostic data generated by the variable generator. Optionally, the renewable energy system is implemented so that the mechanical apparatus includes at least one of: a tidal water turbine, a wind turbine, an oscillating wind vane, an ocean float, a hydroelectric turbine, a steam turbine.

According to a fifth aspect of the invention, there is provided a method of maintaining a variable generator, the generator being pursuant to the first aspect of the invention, the method including steps of:

- (a) determining operating status of modules of the generator;
- (b) unplugging and replacing one or more defective modules as identified in step (a).

According to a sixth aspect of the invention, there is provided a method of providing responsive load stabilization to an electrical distribution grid by using a variable electrical generator pursuant to the first aspect of the invention, the generator being coupled to the grid, characterized in that the method includes:

- (a) sensing one or more parameters indicative of a degree of electrical loading being experienced by the grid;
 - (b) adjusting wavelet selection in the generator to absorb or inject electrical power into the grid so as to assist to stabilize the grid against deviations in voltage and/or frequency of said grid resulting from said degree of electrical loading.
- It will be appreciated that features of the invention are susceptible to being combined in various combinations.

DESCRIPTION OF THE DIAGRAMS

Embodiments of the present invention will now be described, by way of example only, with reference to the following diagrams wherein:

FIG. 1 is an illustration of an embodiment of a variable electrical generator pursuant to the present invention, and a representation of synthesis of an output waveform by combining wavelets in various combinations;

FIG. 2A is an illustration of an embodiment of a variable electrical generator pursuant to the present invention, wherein the generator is implemented in a wide-diameter form;

FIG. 2B is an illustration of an embodiment of a variable electrical generator pursuant to the present invention, wherein the generator is implemented in a long narrow-diameter form;

FIG. 2C is an illustration of an embodiment of a variable electrical generator pursuant to the present invention, wherein the generator is implemented to include a central stationary stator with associated modules, and a rotatable rotor circumferentially surrounding the stator;

FIG. 3 is a further illustration of output waveform synthesis by using wavelets which are in phase and in quadrature phase for achieving an improved quality of synthesis, thereby reducing a need for output filtering to remove harmonic content present in the output from the generator;

FIG. 4 is an illustration of a central stator of an embodiment of a variable electrical generator pursuant to the present invention;

FIG. 5 is an illustration of a spiral disposition of modules along a stator of an embodiment of a variable generator pursuant to the present invention;

FIG. 6A is an illustration of a ring-type rotor element of a rotor of an embodiment of a generator pursuant to the present invention;

FIG. 6B is an illustration of a set of ring-type rotor elements arranged in a phase-offset manner, the rotor elements forming a part of a rotor of an embodiment of a generator pursuant to the present invention;

FIG. 7 is a schematic illustration of a module of a stator suitable for constructing a generator pursuant to the present invention;

FIG. 8A is a schematic illustration of an embodiment of an electrical power circuit for use in modules of the invention;

FIG. 8B is a schematic illustration of a matrix electrical connection arrangement of modules of the invention;

FIG. 9 is a schematic diagram of an offshore wind turbine system, namely a wind "farm", including a plurality of wind turbines equipped with variable generators pursuant to the present invention; and

FIG. 10 is a schematic diagram of an embodiment of a generator pursuant to the present invention for converting linear motion, for example reciprocating linear motion, to electrical energy in a variable manner.

In the accompanying diagrams, an underlined number is employed to represent an item over which the underlined number is positioned or an item to which the underlined

5

number is adjacent. A non-underlined number relates to an item identified by a line linking the non-underlined number to the item. When a number is non-underlined and accompanied by an associated arrow, the non-underlined number is used to identify a general item at which the arrow is pointing.

DESCRIPTION OF EMBODIMENTS OF THE INVENTION

The present invention is based upon a concept which is illustrated in FIG. 1, namely that an alternating power output **10** provided from an electrical generator **20** is susceptible to being synthesized by selectively switching a large number of smaller wavelets **30** which have a magnitude p and a duration d which are considerably smaller and shorter respectively than a magnitude M and a duration D of the alternating power output **10** provided from the generator **20**. If required, a filter **40**, for example implemented by a combination of inductors and capacitors, may be employed to filter high-order harmonic signal components present in the output **10** from the generator **20**. A benefit of this approach is that the wavelets **30** are capable of being switched rapidly in response to dynamically changing input rotation directions or rotation speeds of a rotor **50** of the generator **20**. Moreover, mass-produced solid state electronic modules **80** can be employed which are dedicated to switching their respective wavelets **30**. Moreover, the modules **80** are beneficially implemented to be individually controllable, for example via a general optical data bus from a control unit **70** operable to direct operation of the generator **10**. Such a manner of operation is beneficial because failure of a few of the modules **80** does not disable operation of the generator **10** in general, but merely results in potentially a more coarsely synthesized output **10**. Furthermore, the modules **80** can be mounted in a stacked arrangement along the rotor **50** and/or stator **60** for ensuring a more uniform and manageable potential gradient occurs in operation, thereby reducing any risk of electrical breakdown or flash-over. The aforementioned wavelets **30** are generated by employing relatively small magnetic poles and associated magnets **90** disposed around the rotor **50** and its associated stator **60** for generating the wavelets **30** at various different angular positions of the rotor **50** relative to the stator **60**. Electrically insulating cooling fluid, for example synthetic silicone oil or forced air, is circulated through the modules **80** to remove heat generated therein when in operation. Optionally, the rotor **50** and the stator **60** have fitted thereto an angular sensor, for example an optical encoder, for providing the control unit **70** with an indication of the rotation angle of the rotor **50** relative to the stator **60**. In operation, the generator in FIG. 1 optionally receives an external synchronization signal S , and is operable to couple wavelets generated by the modules **80** at appropriate times to generate the output **10** synchronized to the signal S . However, it will be appreciated that the wavelets can be switched in such a manner that the generator of FIG. 1 is also capable of generating a direct current (DC) output **10** as well as an alternating current (AC) output **10**.

The generator **20** is capable of being employed in a direct drive manner, for example where it is directly coupled to, or even integral with, a turbine. Alternatively, the generator **20** may be coupled via a gearbox, for example a fixed-ratio gearbox, to a turbine. Thus, the generator **20**, also referred to as a variable voltage generator "VVG", is capable of operating as a direct-drive apparatus. The generator **20** may be specifically designed for direct-drive applications where input speed and torque to the generator **20** varies considerably, for example in response to changing tidal or wind conditions. Example applications for the generator **20** can be

6

on-shore or off-shore wind turbines or underwater tidal turbines. Moreover, the generator **20** is also susceptible to being employed in free-cylinder reciprocating combustion machines devoid of a crankshaft structure. The generator **20** of FIG. 1 will now be described in greater detail.

On account of its modular form of construction and operation, the generator **20** is intrinsically capable of providing several additional benefits. For example, the generator **20** is capable of adapting its operation between:

- (a) a stand-alone mode of operation; and
- (b) a coordinated mode of operation which allows the generator **20** to function in conjuncture with other units, thereby enabling highly robust systems to be constructed which are tolerant to multiple component failures within the generator **20**. Such a degree of robustness renders the generator **20** ideal for renewable energy applications, for example in offshore wind turbine applications where high reliability is important on account of access for maintenance purposes being restricted, for example during stormy winter conditions. In operation, the generator **20** is capable of generating output at any desired frequency, overall waveform shape, voltage magnitude and phase relative to a reference signal; the generator **20** can even generate direct current (DC), thereby avoiding a need for rectification components external to the generator **20**.

Although the wavelets **30** are illustrated in FIG. 1 as being in phase and of mutually of similar size, it will be appreciated that the generator **20** may be constructed so that the wavelets **30** have mutually different polarities, mutually different relative phases and mutually different magnitudes. Beneficially, the magnets **90** and their associated modules **80** are disposed in a spiral manner as illustrated in FIG. 1 to obtain various relative phases for the wavelets **30** to enable the control unit **70** to finely control the output **10**, for example for synchronizing the output **10** to an electrical power distribution grid. The wavelets **30** can, for example, be implemented as a binary series of magnitude in a manner akin to a binary sequence 1, 2, 4, 8 . . . to enable the magnitude and form of the output **10** to be finely adjusted.

The generator **20** can be constructed to utilize a wide diameter configuration, for example in a pancake-type arrangement as illustrated in FIG. 2A. In order to be regarded as a "wide diameter" generator, the diameter of the rotor **50**, similarly the stator **60**, should be in an order of at least 1.5 times greater than its axial active length. Alternatively, the generator **20** can be implemented in a long but small diameter configuration as illustrated in FIG. 2B. In order to be regarded to be a "long rotor" generator, the rotor **50** is beneficially in an order of at least 1.5 times longer than its diameter, with the stator **60** implemented along a length of the rotor **60**. In FIG. 2C, the generator **20** is implemented such that rotor **50** encloses the stator **60**, wherein the stator **60** is stationary in operation and central to the generator **20**. The modules **80** are each beneficially implemented as an integrated subunit with one or more associated pickup coils. Moreover, the modules **80** are beneficially arranged in several rows or spirals in respect of a rotating axis of the generator **20**. The number of magnets **90** and coils of the modules **80** determines a generating power output capability of the generator **20**. Moreover, the waveform output resolution of the generator **20** is beneficially adapted in each case to an intended range of operating speeds expected for the generator **20**.

Conventional variable generator designs are operable to rectify power signals generated by generator pickup coils to generate a rectified output which is then phase-formed using power electronic components to produce a final output power signal having a desired frequency, phase and voltage magni-

tude. Such power electronic components are expensive, inflexible and cause much localized energy loss, namely “hotspots”, which can result in a single point of critical failure. The power electronic components are usually implemented as high-frequency switching devices, for example power field-effect-transistors (FETS), thyristors, Darling-
 5 ton transistors and similar, capable of chopping the rectified signal, for example in a pulse-width-modulated (PWM) manner, to synthesize an output power signal which is amplitude, frequency and phase adjusted.

In contradistinction, generators implemented pursuant to the present invention perform in quite a different manner in comparison to aforementioned conventional generator designs. Thus, conventional variable generators perform two
 15 separate operations of rectification of alternating coil signals to direct current state (DC), and then subsequent waveform generation using electronic devices to generate a synthesized output signal as conventional employed. Generators **20** (“VVS”) pursuant to the present invention included a plurality of modules **80** for generating wavelets **30** which are then selectively combined by binary switching to synthesize an output power waveform. This approach pursuant to the present invention provides the following benefits:

- (a) wavelet **30** switching can occur at a much lower frequency
 25 which reduces switching losses and thereby improves efficiency, and also enables lower-performance silicon switching devices to be utilized;
- (b) loss of supply of one wavelet **30** does not cause catastrophic failure of the generator **20**; in an event that one or
 30 more of the modules **80** become defective such that their wavelets **30** are not available for output waveform synthesis, the control unit **70** is operable to select amongst other available wavelets **30** to provide a next-best possible synthesis of the output **10**.

An adaptive control system of the control unit **70** steers power flow within the generator **20** so that outputs of the individual coils **80** are re-arranged in cooperation with all the other coils **80** in real time to produce the desired output **10**,
 40 irrespective of the input frequency as determined by a rotation rate of the rotor **50**. Since control electronic components of each module **80** only deal with their own associated pickup coil **80**, for example each pickup coil **80** having a maximum power in a range of 5 kW to 10 kW, considerable amounts of power within the generator **20** can be controlled and modulated
 45 with simple mass-produced off-the-shelf electronic switching components. Thus, generators **20** pursuant to the preset invention eliminate conventional rectification and phase forming stages of conventional generator systems, thereby providing cost savings, more efficient operation and more
 50 reliable operation.

In FIG. 3, there is shown a combination of wavelets **30** to synthesize sinusoidal output waveforms for the output **10**, namely by employing wavelets **30** which are mutually in quadrature phase. An approximate half sinusoidal signal **110**
 55 is thus generated as illustrated at the top region of FIG. 3 by combining one in-phase wavelet **30A** with two quadrature wavelets **30B** and three in-phase wavelets, wherein the wavelets are of similar polarity. It is feasible to synthesize a half sinusoidal signal of longer relative duration by combining more wavelets **30D**, **30E**, **30F**, **30G** as illustrated at a bottom
 60 region of FIG. 3. By combining these individual wavelets, almost any range of frequencies, voltages and currents can be provided at the output **10**, namely independently of the input frequency determined by rotation rate of the rotor **50**, without the need to rectify or phase-form signals generated by the coils.

In FIG. 4, a practical implementation for the stator **60** is shown, wherein the rotor **50** (not shown in FIG. 4) is disposed in a peripheral manner as illustrated in FIG. 2C; the stator **60** is thus beneficially stationary in operation, thereby rendering
 5 cable coupling to the stator **60** possible without a need to use slip-rings. It will be appreciated that the generator **20** experiences considerable mechanical stresses when designed to generate in an order of MegaWatts (MW) of electrical power such that the magnets **90** and the modules **80** need to be mechanically robust and properly mechanically supported,
 10 for example to withstand centrifugal forces. For example, the magnets **90** are beneficially fabricated from Neodymium materials and supported in a compliant polymer or rubber mount of the rotor **50** to spread forces to avoid snapping or fracture of the permanent magnets **90** in operation; for
 15 example, polyurethane bedding of the magnets **90** is optionally employed. The modules **80** are robustly mechanically supported as well as being provided with cooling. Furthermore, the modules **80** are beneficially stacked together in a manner to ensure a gradual potential gradient occurs in operation therealong; such potential distribution is especially
 20 important when the generator **20** is to provide the output **10** at a magnitude in an order of kilovolts (kV) to avoid any tendency to flash-over. The modules **80** are beneficially mounted onto an insulating central tube **150** through which forced air cooling or cooling liquid is circulated in operation; for example, electrically-insulating and substantially optically-transparent silicone oil is beneficially employed as a liquid
 25 coolant. The modules **80** are beneficially mounted onto axial vanes **160** projecting from the central tube **150**, wherein the vanes **160** are in thermal communication with the central tube **150**. Magnetic pole pieces **170**, for example fabricated from laminate silicon steel, of the modules **80** are beneficially mounted in respect of the vanes which are both robust, able
 30 to resist stress, and yet offer a degree of flexibility to cope with mechanical shocks which could otherwise damage the generator **20**. The modules **80** are beneficially mutually similar to enable the stator **60** to be fabricated from mass-produced items for reducing its cost. Moreover, when the generator **20** requires servicing, any defective modules **80** can be readily
 35 diagnosed and them subsequently unplugged from the vanes **160** and/or the central tube **150** and substituted with corresponding new functional modules **80**. Beneficially, the modules **80** are provided with a shared optical communication highway, for example implemented in a manner akin to Ethernet, for enabling control signals to be sent from the control
 40 unit **70** to the modules **80** for controlling switching of the modules **80**, and for conveying feedback signals from the modules **80** back to the control unit **70** indicative of operation of the modules **80**. If required, optical wavelength division multiplexing (WDM) can be employed for different categories of control and feedback signals exchanged between the modules **80** and the control unit **70**. Moreover, optical radiation conveyed via the optical highway can be used to provide
 45 power for control electronic components included in each of the modules **80**, for example using power-generating photo-cells included in the modules, there providing electrical isolation. Use of optical radiation is of especial benefit because:
 50 (a) it is relatively immune to electrical interference;
 (b) it provides for relatively high communication data rates to and from the modules; and
 (c) it provides an intrinsic approach to electrical isolation between modules **80** which would not be possible in an alternative configuration wherein electrical control signals were employed.

Optionally, the modules **80** are disposed in a slightly spiral manner onto the stator **60** as illustrated in FIG. 5 for enabling

improved waveform synthesis to be achieved in operation with greater phase resolution by way of providing a range of wavelets **30** with mutually slightly differing phase characteristics.

When a configuration for the generator **20** is employed as illustrated in FIG. **1**, the rotor **50** is beneficially fabricated from a series of ring elements as indicated by **300** in FIG. **6A**. Each ring element **200** includes permanent magnets **210**, for example Neodymium ceramic permanent magnets, disposed around a ring-like support **220** which can be rigidly mounted to a supporting shaft in operation. The magnets **210** are implemented in a radial vane-like manner with air gaps therebetween as illustrated. Moreover, vane-like projections from the support **220** assist to support the magnets **210** mechanically which are subject to major stress when the generator **20** is in operation providing large quantities of output power, for example in an order of several hundred kW's, or even several MW's.

Several of the ring elements **220** can be mounted axially together with an angular displacement therebetween as illustrated in FIG. **6B** for providing the control unit **70** with a greater choice of wavelets **30** which can be combined to generate the output **10**. Thus, the rotor **50** is susceptible to being constructed from a multiple of ring elements **220** which are robustly assembled together. In an event that one or more of the elements **220** become damaged, for example their magnets **90** become fractured, they can be simply replaced in their entirety during routine maintenance of the generator **20**. The ring elements **220** are beneficially constructed from one or more of: metal, carbon fiber, composite materials, plastics polymer materials, ceramic materials. The rotor **50** and the stator **60** are mounted together within a housing with an appropriate arrangement of bearings so that the rotor **50** is operable to rotate relative to the stator **60** to generate electrical power at the output **10**. Mechanical and/or magnetic bearings and/or fluid bearings can be employed, depending upon application for the generator **20** and its designed power generating capacity.

The modules **80** will now be described in greater detail with reference to FIG. **7**. Each module **80** is a self-contained wavelet **30** generator which can be mounted in a stacked configuration against other similar modules **80**, or mounted onto supports of a supporting structure of the stator **60** as aforementioned. The module **80** is provided with a cooling arrangement **300**, for example based upon circulated insulating silicone cooling oil and/or forced air cooling. Moreover, the module **80** also includes a releasable mounting arrangement **310** for enabling the module **80** to be adequately mechanically supported when exposed to various mechanical stresses when in operation; the mounting arrangement **310** beneficially includes screws, registration pins, rubber bushes and so forth. The module **80** includes a coil **320** for interacting with magnetic flux generated by magnets **90** of the rotor **50**. An output of the coil **320** is coupled to a rectifier arrangement **330** and then via a switching network **340** to the wavelet output **30**; the switching network **340** is designed to operate at relatively low switching frequencies corresponds to the duration *d* of the wavelets **30**. Such operation is very different to conventional high-frequency pulse-width-modulated (PWM) electronic power conditioning circuits which are costly and energy inefficient due to high-frequency switching losses occurring at high frequencies in an order of kHz. Moreover, the module **80** also includes a bi-directional optical interface **360** for receiving control instruction from the control unit **70** and for output diagnostic data and/or confirmatory data to the control unit **70**. The interface **360** is able to provide for rapid data rates as well as providing electrical isolation between

modules **80** in a most robust and cost-effective manner. A microcontroller **350** controls operation of the module **80** at a local level; in practice, control of the generator **20** is beneficially executed in a distributed manner between the control unit **70** and the microcontrollers **350** of the modules **80**. Moreover, the interface **360** is conveniently implemented using high-speed photodetectors and data-modulated solid-state laser devices. As aforementioned, the interface **360** is designed to receive and transmit at various different optical carrier radiation wavelengths, for example in a manner of wavelength division multiplexing (WDM), to enable a single general optical data highway to be used within the generator **20** to control operation of all the modules **80** of the generator **20**. Optionally, a plurality of optical data highways can be employed in the generator **20**, for example for emergency backup purposes in an event that a main optical data highway of the generator **20** becomes obscured for any reason. Each coil **320** and its associated electronic components are constructed as a stand alone mass-produced unit that can easily be replaced, for example even while in operation. The ability to construct the generator **20** as a large-diameter arrangement, or as a long small-diameter arrangement, also lends itself to integration into a wide range of conventional and exotic turbine designs without requiring its basic component parts to be re-designed. As aforementioned, all configurations of the generator **20** can have monopole or dipole magnetic setups with internal or external rotating magnets, for example as depicted in FIG. **2A**, FIG. **2B** and FIG. **2C**.

Referring next to FIG. **8A**, there is shown a representation of electronic switching components employed to implement the module **80**. The module **80** can be implemented using a variety of electronic switching components, for example field effect transistors (FET), bipolar transistors (BJT), triacs, silicon controlled rectifiers (SCR), Darlingtons transistors, silicon carbide transistors, silicon germanium transistors, and so forth. Most preferable, on account of low cost and robustness, the module **80** is implemented using silicon controlled rectifiers SCR1 to SCR8 as illustrated. Silicon controlled rectifiers SCR are purchasable to have up to 2 kV blocking voltage performance, a current conducting performance of several thousand amperes and be packaged in flat ceramic capsules which are easily mechanically incorporated into the module **80**. The silicon controlled rectifiers SCR include gate terminals which are triggered from the microcontroller **350** of the module **80**; triggering of the silicon controlled rectifiers SCR is beneficially achieved via optical triggering and/or via isolation ferrite pulse transformers. In operation, a silicon controlled rectifier SCR only conducts when triggered at its gate terminal. Moreover, conduction through a silicon controlled rectifier SCR ceases when a potential thereacross is smaller than a threshold magnitude or the silicon controlled rectifier SCR becomes reversed biased across its main two terminals. The module **80** in FIG. **8A** has four conducting modes, namely:

- (a) a first mode, wherein the module **80** provides effectively a short-circuit path between its terminals **T1**, **T2**;
- (b) a second mode, wherein there is an open circuit between the terminals **T1**, **T2**;
- (c) a third mode, wherein a negative wavelet **30** half-cycle is directed from the coil **320** to the terminals **T1**, **T2**; and
- (d) a fourth mode, wherein a positive wavelet **30** half-cycle is directed from the coil **320** to the terminals **T1**, **T2**.

Beneficially, the module **80** includes a first safety fuse **FS1** for isolating the entire module **80** in a situation of gross failure, and a second safety fuse **FS2** for protecting the coil **320** in a situation of gross failure. The silicon controlled rectifiers SCR1 to SCR8 are arranged in a bridge-type con-

figuration as illustrated in FIG. 8A. In the first mode, the silicon controlled rectifiers SCR3, SCR4, SCR7 and SCR8 are triggered into a conducting state, whereas the silicon controlled rectifiers SCR1, SCR2, SCR5 and SCR6 are in a non-conducting state. In the second mode, none of the silicon controlled rectifiers SCR1 to SCR8 are in a conducting state, namely they are all in an open-circuit state. In the third mode, the silicon controlled rectifiers SCR2 and SCR7 are in a conducting state, and the silicon controlled rectifiers SCR1, SCR3 to SCR6, and SCR8 are in a non-conducting state. In the fourth mode, the silicon controlled rectifiers SCR1 and SCR8 are in a conducting state, and the silicon controlled rectifiers SCR2 to SCR7 are in a non-conducting state.

As illustrated in FIG. 8B, the modules 80 are beneficially coupled electrically together in a two-dimensional matrix including $m \times n$ modules 80. Certain of the modules 80 are optionally omitted from the matrix. By such an arrangement, current load can be shared between modules 80 coupled in parallel, and large potentials can be provided at the output 10 by the modules 80 being coupled in series. For example, if required, the output 10 can be many kV's in magnitude which potentially circumvents a need to interface the generator 20 via transformers to an electrical distribution grid, thereby saving installation cost and reducing energy losses. Optionally, the matrix includes several hundred modules 80 for synthesizing the output 10 as a sinusoidal signal with relatively little harmonic content, for example less than 1% harmonic content. As aforementioned, the modules 80 of the matrix optionally provide mutually different wavelet 30 amplitudes for enabling even more accurately synthesized waveforms to be synthesized for the output 10. However, it will be appreciated that the matrix can also be controlled to provide direct current DC output which can be fed directly to long-distance submerged ocean cables for reducing long-distance power transmission losses.

The variable generator 20 ("VVG") provides many intrinsic benefits in comparison to conventional approaches to generator construction. Conceptually, the variable generator 20, for example adapted for use in an offshore wind turbine for electrical power generation, can be considered to be a spatial collocation of small power plants that can be dynamically rearranged to combine their power outputs in various combinations to absorb energy from an electrical power network or supply energy to the electrical power network; such absorption or supply can be achieved by adjusting phase of the output 10 relative to phase of an electrical grid to which the generator 20 is coupled, namely by selecting time instances when the wavelets 30 are selectively added together to generate the output 10. Alternatively, or additionally, power absorption or power supply can also be controlled by modulating a magnitude of the output 10, namely by how many wavelets 30 that the control unit 70 elects to combine to synthesize its output waveform at the output 10. Situations where power absorption is desirable arise when an electrical grid is momentarily overloaded and power needs to be extracted from the grid to be stored in rotational inertia of the rotor of the wind turbine. A situation when power supply to the electrical grid is required is when numerous consumers are extracting power from the electrical power network. The generator 20, when used in an offshore wind turbine, is thus capable of providing electrical power output as well as very rapid electrical grid network demand response stabilization with a response time potentially within one mains electricity cycle. Such demand response stabilization is vastly more prompt than any pump storage systems which are conventionally used for electrical power grid stabilization; an example of a pump storage demand response stabilization facility is

Dinorwig in Wales, United Kingdom. The generator 20 is thus highly suitable for use with smart grids (in USA, "super-grid").

In principle, various measured parameters can be used by the microcontrollers 350 and/or the control unit 70 to control the generator 20, or even a configuration of several generators 20 operating together in a coordinated manner. An example of a measured parameter is temperature within a given module 80, or number of hours a given generator 20 has been operating within a wind farm (for example, for uniformly distributing wear-and-tear amongst generators 20 to enhance overall operating reliability between servicing operations).

For example, referring to FIG. 9, a system 500 comprises several offshore wind turbines 510 equipped with variable generators 20 pursuant to the present invention. The system 500 is beneficially operated according to a method wherein a control centre 520 of the system 500 decides, by way of an independent decision, to start the wind turbines 510 in a western region 530 of the system 500, namely a wind "farm", first if the wind blows from a westerly direction; in other words, the system 500 activates those wind turbines 510 which are capable of generating energy most efficiently first. Beneficially, the control units 70 of the generators 20 employed within the system 500 are operable to maintain a temporal log of accumulative output power from the generators 20, for example for spreading wear-and-tear within the system 500 and/or for determining maintenance schedules for the system 500.

In another method of operation, the control centre 520 seeks to set in operation first a wind turbine 510 that has hitherto produced least output, for example in order to spread wear-and-tear and/or to prevent seldom-used mechanisms seizing up in corrosive offshore environments. The control centre 520 is optionally an automatic arrangement controlling the system 500 without a need for human intervention. Optionally, the control centre 520 is adaptive and refines its operating routines for the wind turbines 510 based upon feedback from monitoring the outputs 10 and from receiving information from maintenance activities.

Beneficially, control logic employed for the system 500 is based on a self-organizing neural control; this type of neural control means that the system 500 itself will at any given time decide an optimum operating scenario of a single generator 20 or a combination of generators 20 based on predetermined values set by an operator of the system 500. Any value desired by the operator can be integrated in a control algorithm employed for a single unit or the entire system 500. An example could be to operate the system 500 in such a way that it maximizes output but minimizes maintenance, and additionally minimizes temperature in the individual components of the electronic subunits, and so forth. Other measures could, for instance, be to optimize power output of a generator 20 of the system 500, or the entire system 500, but allow optimized power to be overridden by responsive load demands exhibited by an electrical power grid coupled to the system 500. Beneficially, automatic system compensation is adopted by the system 500 in an event that one or more of the generators 20 or their associated wind turbines 510 fail, experience seasonal variations, and so forth.

Methods of making decision are beneficially based on criteria which are decided and weighted by an operator of the system 500; these methods allow the system 500 to prioritize independently in real time based on whatever system operating effects are desired. The system 500 could, for example, be instructed to maintain absolute voltage and frequency control at its point of delivery at any given time, or even compensate/counteract noise on the electric power grid if this is desired.

The generators **20** are beneficially susceptible to being adapted to smart unit and smart grid scenarios.

If an individual wind turbine **510** experiences a gust of wind that could potentially create a short unwanted power boost onto an electrical distribution grid coupled to the turbine **510**, the generator **20** of the wind turbine **510** is beneficially operable to counteract an electrical power surge resulting from the boost by enabling a rotor of the wind turbine **510** to accelerate so that energy of the gust is converted to rotational kinetic energy of the rotor. This operating characteristic is capable of enabling a more stable electrical supply grid to be achieved. In a coordinated scenario, in an event that a base load in the grid suddenly drops by 100 MW, for example everyone unplugs their electric automobiles to drive to work, a wind turbine farm employing generators **20** and producing 100 MW at the time could instantaneously switch and in reality produce momentarily 100 MW of additional power by decelerating rotors of the wind turbines **510**. Such an approach reduces a need for short-term load shedding to be implemented within the electrical distribution grid. The system **500** beneficially continually adjusts itself and failure in any individual component or unit therein will have a negligible effect on the overall performance of the system **500**. If a component fails in the system **500**, the only negative effect would be a power loss equal to the failed component. This is a very useful feature, especially if the production unit is placed in a remote area, offshore or underwater and the next planned maintenance interval is a long time off. Not only can the generator **20** adapt in real time to noise or unbalanced loads, but it can also act as an instantaneous load shedder equal at any given time to the instantaneous power produced by the system **500** either in an individual production unit or distributed across a number of independent production units.

The generator **20** is optionally susceptible to being modified to function as a component part of a linear generator for converting reciprocating linear motion resulting from combustion processes to electrical energy, for example as a component part of an apparatus as described in granted European patent EP0772735B1. In renewable energy systems, reciprocating linear motion also arises as a consequence of floats bobbing up and down on ocean waves, and in oscillating-vane wind energy devices; such motion is also beneficially converted to electrical energy using the generator **20**. In FIG. **10**, the stator **60** is shown disposed in a linear planar matrix, optionally a skewed or irregular matrix, for interfacing to a linear reciprocating "rotor" **50** equipped with a plurality of magnets **90**.

Although inclusion of the magnets **90** in the rotor **50** and coils **320** in the stator **60** are described in the foregoing, it will be appreciated that each of the stator **60** and rotor **50** optionally include both magnets **90** and coils **320** in a hybrid type of arrangement. Optionally, slip rings and/or magnetic inductive couplings can be used for transferring generated power.

Although use of the generator **20** in renewable energy systems is described most in the foregoing, it will be appreciated that the generator **20** can be adapted for use in more convention installations, for example:

- (a) in hydroelectric facilities;
- (b) in conjunction with steam turbines of coal, nuclear, gas, solar and geothermal power stations.

Modifications to embodiments of the invention described in the foregoing are possible without departing from the scope of the invention as defined by the accompanying claims. Expressions such as "including", "comprising", "incorporating", "consisting of", "have", "is" used to describe and claim the present invention are intended to be construed in a non-exclusive manner, namely allowing for items, components or

elements not explicitly described also to be present. Reference to the singular is also to be construed to relate to the plural. Numerals included within parentheses in the accompanying claims are intended to assist understanding of the claims and should not be construed in any way to limit subject matter claimed by these claims.

The invention claimed is:

1. A variable electrical generator (**20**) for converting mechanical motion to electrical power, wherein the generator (**20**) includes at least a stator element (**60**) and a rotor element (**50**) including coils (**320**) and magnets (**90**), wherein the generator (**20**) includes a configuration of modules (**80**) including the coils (**320**) for generating wavelets (**30**) in response to the coils (**320**) interacting magnetically with the magnets (**90**), and wherein the modules (**80**) are operable to generate wavelets (**30**) whose duration (d) is shorter than a duration of cycle (D) of an alternating waveform supplied in operation to the output (**10**), and a control arrangement (**70**) for selectively combining the wavelets (**30**) for generating a composite synthesized power output (**10**) from the generator (**20**).

2. A variable electrical generator (**20**) as claimed in claim 1, wherein the modules (**80**) are spatially collocated with their corresponding coils (**320**).

3. A variable electrical generator (**20**) as claimed in claim 1, wherein the stator (**60**) includes coils (**320**) and is arranged to remain substantially stationary in operation, and the rotor (**50**) includes magnets (**90**) and is arranged to rotate and/or reciprocate in operation relative to the stator (**60**).

4. A variable electrical generator (**20**) as claimed in claim 1, wherein the modules (**80**) are electrically coupled together in a two-dimension switching matrix including at least one series path for adding potentials of the wavelets (**30**), and at least one parallel path for current spreading between wavelets (**30**), for generating the output (**10**).

5. A variable electrical generator (**20**) as claimed in claim 1, wherein the modules (**80**) are operable to switch between a non-conductive state, a shorted state, a negative wavelet state and a positive wavelet state when in operation in response to control signals provided from the control arrangement (**70**, **80**).

6. A variable electrical generator (**20**) as claimed in claim 1, wherein the modules (**80**) are coupled in communication with the control arrangement (**70**, **80**) via an optical data highway (**360**) which is operable to selectively direct data between the control arrangement (**70**) and the modules (**80**) by way of wavelength division multiplexing and wherein the modules (**80**) are operable to communicate diagnostic signals regarding their operating status to the control arrangement (**70**), and to receive control signals from the control arrangement (**70**) concerning timing information and/or polarity information in respect of their respective wavelets (**30**).

7. A variable electrical generator (**20**) as claimed in claim 1, wherein said modules (**80**) are arranged to be unplugged and plugged into their respective positions on the stator (**60**) and/or rotor (**50**).

8. A variable electrical generator (**20**) as claimed in claim 1, wherein the modules (**20**) include solid state switching devices (**330**, **340**) for switching at least half-cycles of induced electrical signals induced within the coils (**320**) in operation.

9. A variable electrical generator (**20**) as claimed in claim 1, wherein the control arrangement (**70**) includes an input for use as a reference when synchronizing and/or adjusting an amplitude and/or phase of the output (**10**) during operation.

10. A module (**80**) for use in a variable generator (**20**) as claimed in claim 1, wherein the module (**80**) includes a micro-

15

controller (350) for providing local control of the module (80), a coil (320) coupled to a switching arrangement (330, 340) for generating wavelets (30) under control of the micro-controller (350), and an optical communication interface (260) for receiving control data for controlling the module (80) and/or for communicating diagnostic information from the module (80).

11. A method of using a variable electrical generator (20) for converting mechanical motion to electrical power, wherein the generator (20) includes at least a stator element (60) and a rotor element (50) including coils (320) and magnets (90), wherein the method comprises:

- (a) generating wavelets (30) whose duration (d) is shorter than a duration of cycle (D) of an alternating waveform supplied in operation to the output (10), in a configuration of modules (80) including the coils (320) for generating wavelets (30) in response to the coils (320) interacting magnetically with the magnets (90); and
- (b) using a control arrangement (70) to selectively combine the wavelets (30) for generating a composite synthesized power output (10) from the generator (20).

12. A renewable energy system (500) for converting linear and/or rotating motion of mechanical apparatus (510) into electrical energy, wherein the apparatus (500) is operable to cause relative movement between a rotor (50) and a stator

16

(60) of a variable generator (20) as claimed in claim 1 for generating a power output (10) from the system (500).

13. A renewable energy system (500) as claimed in claim 12, wherein said mechanical apparatus includes at least one of: a tidal water turbine, a wind turbine, an oscillating wind vane, an ocean float, a hydroelectric turbine, a steam turbine.

14. A method of maintaining a variable generator (20) as claimed in claim 1, comprising the steps of:

- (a) determining operating status of modules (80) of the generator (20); and
- (b) unplugging and replacing one or more defective modules (80) as identified in step (a).

15. A method of providing responsive load stabilization to an electrical distribution grid by using a variable electrical generator (20) as claimed in claim 1, the generator (20) being coupled to the grid, wherein the method comprises:

- (a) sensing one or more parameters indicative of a degree of electrical loading being experienced by the grid; and
- (b) adjusting wavelet (30) selection in the generator (20) to absorb or inject electrical power into the grid so as to assist to stabilize the grid against deviations in voltage and/or frequency of said grid resulting from said degree of electrical loading.

* * * * *