



- (51) **International Patent Classification:**  
B41F 13/00 (2006.01) B41F 31/00 (2006.01)  
B41F 9/02 (2006.01)
- (21) **International Application Number:**  
PCT/IB2010/055942
- (22) **International Filing Date:**  
20 December 2010 (20.12.2010)
- (25) **Filing Language:** English
- (26) **Publication Language:** English
- (30) **Priority Data:**  
09180318.9 22 December 2009 (22.12.2009) EP
- (71) **Applicant (for all designated States except US):** KBA-NotaSys SA [CH/CH]; 55, Avenue du Grey, PO Box 347, CH-1000 Lausanne 22 (CH).
- (72) **Inventors; and**
- (75) **Inventors/Applicants (for US only):** SCHAEDE, Johannes, Georg [DE/DE]; Max-Heim-Strasse 8, 97074 Würzburg (DE). SCHWITZKY, Volkmar, Rolf [DE/DE]; Flürleinstrasse 28, 97076 Würzburg (DE).
- (74) **Agent:** NOLL, Ronald; c/o UniConcept IP Solutions Sàrl, Au Trésy 22, CH-1125 Monnaz (CH).
- (81) **Designated States (unless otherwise indicated, for every kind of national protection available):** AE, AG, AL, AM, AO, AT, AU, AZ, BA, BB, BG, BH, BR, BW, BY, BZ, CA, CH, CL, CN, CO, CR, CU, CZ, DE, DK, DM, DO, DZ, EC, EE, EG, ES, FI, GB, GD, GE, GH, GM, GT, HN, HR, HU, ID, IL, IN, IS, JP, KE, KG, KM, KN, KP, KR, KZ, LA, LC, LK, LR, LS, LT, LU, LY, MA, MD, ME, MG, MK, MN, MW, MX, MY, MZ, NA, NG, NI, NO, NZ, OM, PE, PG, PH, PL, PT, RO, RS, RU, SC, SD, SE, SG, SK, SL, SM, ST, SV, SY, TH, TJ, TM, TN, TR, TT, TZ, UA, UG, US, UZ, VC, VN, ZA, ZM, ZW.
- (84) **Designated States (unless otherwise indicated, for every kind of regional protection available):** ARIPO (BW, GH, GM, KE, LR, LS, MW, MZ, NA, SD, SL, SZ, TZ, UG, ZM, ZW), Eurasian (AM, AZ, BY, KG, KZ, MD, RU, TJ, TM), European (AL, AT, BE, BG, CH, CY, CZ, DE, DK, EE, ES, FI, FR, GB, GR, HR, HU, IE, IS, IT, LT, LU, LV, MC, MK, MT, NL, NO, PL, PT, RO, RS, SE, SI, SK, SM, TR), OAPI (BF, BJ, CF, CG, CI, CM, GA, GN, GQ, GW, ML, MR, NE, SN, TD, TG).
- Published:**  
— with international search report (Art. 21(3))

(54) **Title:** INTAGLIO PRINTING PRESS WITH INK-COLLECTING CYLINDER

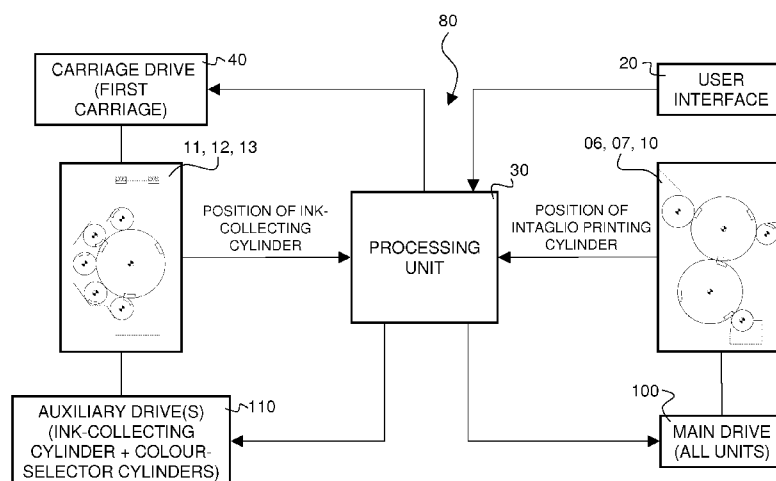

Fig. 6

(57) **Abstract:** There is described an intaglio printing press comprising (i) a stationary machine frame (01) supporting an intaglio printing cylinder (07) and an impression cylinder (06) contacting the intaglio printing cylinder (07), and (ii) an inking system (12, 13, 16) for inking the intaglio printing cylinder (07), which inking system (12, 13, 16) comprises an ink-collecting cylinder (12) designed to contact the intaglio printing cylinder (07) and at least one inking device (13, 16) for supplying ink to said ink-collecting cylinder (12). The intaglio printing press further comprises a driving system (110; 115; 116) for rotating the ink-collecting cylinder (12) independently of the intaglio printing cylinder (07) and the impression cylinder (06) at least during maintenance operations.

WO 2011/077350 A1

## INTAGLIO PRINTING PRESS WITH INK-COLLECTING CYLINDER

### PREAMBLE - TECHNICAL FIELD

The present invention generally relates to intaglio printing presses. More precisely, the present invention relates to an intaglio printing press comprising :

- (i) a stationary machine frame supporting an intaglio printing cylinder and an impression cylinder contacting the intaglio printing cylinder ; and
- 5 (ii) an inking system for inking the intaglio printing cylinder, which inking system comprises an ink-collecting cylinder designed to contact the intaglio printing cylinder and at least one inking device for supplying ink to the ink-collecting cylinder.

Preferably, the intaglio printing press is of a type further comprising at  
10 least a first mobile carriage supporting the ink-collecting cylinder, which first mobile carriage is adapted to be moved with respect to the stationary machine frame between a working position where the ink-collecting cylinder contacts the intaglio printing cylinder and a retracted position where the ink-collecting cylinder is retracted away from the intaglio printing cylinder.

15 The present invention further relates to a mobile carriage for an intaglio printing press, which mobile carriage supports an ink-collecting cylinder designed to contact an intaglio printing cylinder which is supported in a stationary machine frame of the intaglio printing machine.

### BACKGROUND OF THE INVENTION

An intaglio printing press and mobile carriage of the above-mentioned  
20 types are disclosed in International Application No. WO 03/047862 A1 (which corresponds to US Patent No. 7,011,020 B2 in the name of the present Applicant) which intaglio printing press is reproduced in Figures 1A and 1B hereof. The intaglio printing press disclosed in this document comprises a first mobile carriage 11 supporting the ink-collecting cylinder 12 (also referred to as  
25 "Orlof cylinder"), as well as four colour-selector cylinders 13 (also referred to as "chablon cylinders") and a second mobile carriage 14 supporting four inking units 16 associated to the colour-selector cylinders 13. On the other hand, the plate cylinder 07 (or "intaglio printing cylinder") and the impression cylinder 06

(with its sheet grippers 08) are supported in a stationary machine frame 01 of the press. According to International Application No. WO 03/047862 A1, the two mobile carriages 11, 14 are suspended under suspension rails 04 below the endless chain gripper system 09 that takes the printed sheets away from the impression cylinder 06 so as to free the floor 02 onto which the printing press is installed from any supporting rails, the suspension rails 04 being supported at one end by the stationary machine frame 01 and at the other end by a supporting upright 03. The axes of rotation of the ink-collecting cylinder 12 and of the plate cylinder 07 are located in the same horizontal plane and movement of the mobile carriages 11, 14 takes place along this horizontal plane. As illustrated in Figure 1A, thanks to this arrangement, a working space 17 big enough for a human operator can be formed between the first and second mobile carriages 11, 14 by moving the second mobile carriage 14 away from the first mobile carriage 11. As shown in Figure 1B, a similarly big working space 18 can be formed between the first mobile carriage 11 and the stationary machine frame 01 by further moving the first mobile carriage 11 away from the stationary machine frame 01.

Swiss Patent No. CH 685 380 A5 and European Patent Application No. EP 0 563 007 A1 (which corresponds to US Patent No. 5,282,417) also disclose an intaglio printing press with first and second mobile carriages. In contrast to the previously-mentioned intaglio printing press, the first mobile carriage exclusively supports the ink-collecting cylinder, the colour-selector cylinders being located in the second mobile carriage together with the associated inking units. This is necessitated by the fact that, according to Swiss Patent No. CH 685 380 A5 and European Patent Application No. EP 0 563 007 A1, the ink-collecting cylinder is adapted to be removed from the press so as to convert the intaglio printing press from a press with indirect inking system to a press with direct inking system, and vice versa. The axes of rotation of the ink-collecting cylinder and of the intaglio printing cylinder are still located in the same horizontal plane and movement of the mobile carriages also takes place along this horizontal plane.

In the above-discussed intaglio printing presses, the ink-collecting cylinder is conventionally driven into rotation by a main drive of the printing press together with the intaglio printing cylinder and impression cylinder, the cylinders being coupled to one another by way of gears. Gears between the ink-collecting cylinder and the intaglio printing cylinder are designed so as to be disconnectable to allow the ink-collecting cylinder to be moved to a retracted position.

A problem with the above-mentioned intaglio printing presses resides in the fact that, upon decoupling of the ink-collecting cylinder from the other cylinders during maintenance operations, the connection to the main drive is also interrupted, which means that the ink-collecting cylinder must be rotated by hand by an operator during the maintenance operations.

Coupling of the ink-collecting cylinder to the main drive of the intaglio printing press via gears as discussed above can furthermore be problematic as disconnectable gears are a mandatory feature. Such disconnectable gears are costly to manufacture and rather complex to use in practice as this requires special systems to ensure proper coupling/uncoupling operations and avoid damaging the gears as a result of interference between the gear teeth. Such disconnectable gears are also problematic in that portions of the gears are exposed as a result of an uncoupling operation, leading to possible lubrication problems and dirtiness issues as lubrication grease may fall out of the exposed gears.

Intaglio printing presses wherein the ink-collecting cylinder is located in the stationary machine frame – rather than in a mobile carriage as discussed above – are also known, for instance from European Patent Applications Nos. EP 0 406 157 A1 and EP 0 873 866 A1. In such intaglio printing presses, the ink-collecting cylinder is likewise conventionally driven into rotation by a main drive of the printing press together with the intaglio printing cylinder and impression cylinder, the cylinders being coupled to one another by way of gears.

A problem with the above-mentioned intaglio printing presses where the ink-collecting cylinder is supported in the stationary machine frame resides in

the fact that the ink-collecting cylinder can only be driven into rotation by the main drive, which means that the impression cylinder and intaglio printing cylinder are also driven into rotation during maintenance operations.

It has therefore become apparent that there was a need for an improved  
5 intaglio printing press of the type comprising an ink-collecting cylinder.

#### SUMMARY OF THE INVENTION

A general aim of the invention is therefore to provide an improved intaglio printing press of the above-mentioned type comprising an ink-collecting cylinder.

A further aim of the invention is to provide such an intaglio printing press  
10 where maintenance operations are facilitated.

These aims are achieved thanks to the intaglio printing press defined in the claims.

There is accordingly provided an intaglio printing press as mentioned in the preamble hereof further comprising a drive system for rotating the ink-  
15 collecting cylinder independently of the intaglio printing cylinder and the impression cylinder at least during maintenance operations.

According to one aspect of the invention, the intaglio printing press comprises a main drive which, during printing operations, drives the intaglio printing cylinder, the impression cylinder and the ink-collecting cylinder into  
20 rotation via gears, and the drive system comprises an auxiliary drive for rotating the ink-collecting cylinder during maintenance operations. Such auxiliary drive is advantageously adapted to rotate the ink-collecting cylinder at low speed and can especially be a servo motor or the like.

According to a second aspect of the invention, the drive system  
25 comprises an independent drive for rotating the ink-collecting cylinder both during printing operations and during maintenance operations. Such independent drive is adapted to rotate the ink-collecting cylinder at high speed and in phase synchronism with the intaglio printing cylinder during printing operations and can especially be a torque motor or the like.

30 According to a preferred embodiment of the invention, the intaglio printing press further comprises at least a first mobile carriage supporting the

ink-collecting cylinder, which first mobile carriage is adapted to be moved with respect to the stationary machine frame between a working position where the ink-collecting cylinder contacts the intaglio printing cylinder and a retracted position where the ink-collecting cylinder is retracted away from the intaglio printing cylinder.

In that respect, it has become apparent that the location of the ink-collecting cylinder in a mobile carriage could be problematic in that one loses the necessary circumferential register between the ink-collecting cylinder and the intaglio printing cylinder as a result of rotating the ink-collecting cylinder during maintenance operations. Indeed, perfect circumferential register between the ink-collecting cylinder and the intaglio printing cylinder is critical in that this circumferential register determines the preciseness of the inking on the intaglio printing cylinder and therefore affects the printing quality.

In addition, as disclosed in International Application No. WO 03/047862 A1, Swiss Patent No. CH 685 380 A5, and European Patent Application No. EP 0 563 007 A1, it had previously been considered necessary to ensure that the axes of rotation the ink-collecting cylinder and of the intaglio printing cylinder should be aligned with the direction of displacement of the mobile carriage supporting the ink-collecting cylinder (i.e. in a horizontal plane) so as to avoid as much as possible occurrence of such circumferential register issues upon separation or joining of the ink-collecting cylinder and of the intaglio printing cylinder. Such horizontal arrangement of the ink-collecting cylinder and of the intaglio printing cylinder however has a negative effect on the machine footprint.

Therefore, according to an advantageous variant of the preferred embodiment of the invention, the intaglio printing press further comprises a correcting and adjusting system for correcting and adjusting a rotational position of the ink-collecting cylinder with respect to a rotational position of the intaglio printing cylinder following maintenance operations to ensure proper circumferential register between the ink-collecting cylinder and the intaglio printing cylinder in the working position of the first mobile carriage, and the drive

system is further used for correcting/adjusting the rotational position of the ink-collecting cylinder.

There is further provided a mobile carriage for an intaglio printing press as mentioned in the preamble hereof comprising a drive system for rotating the  
5 ink-collecting cylinder independently of the intaglio printing cylinder of the intaglio printing press at least during maintenance operations.

Further advantageous embodiments of the invention form the subject-matter of the dependent claims and are discussed below.

According to an additional aspect of the invention, the machine footprint  
10 of the intaglio printing press is reduced and space is optimised thanks to an advantageous arrangement and configuration of the impression cylinder, intaglio printing cylinder and ink-collecting cylinder.

#### BRIEF DESCRIPTION OF THE DRAWINGS

Features and advantages of the present invention will appear more  
15 clearly from reading the following detailed description of embodiments of the invention which are presented solely by way of non-restrictive examples and are illustrated by the attached drawings in which:

Figures 1A and 1B are side views of a known intaglio printing press ;

Figures 2A to 2F are side views of a preferred embodiment of an intaglio  
20 printing press according to the invention ;

Figure 3 is a block diagram schematically illustrating a first embodiment of a driving principle of the intaglio printing press of Figures 2A to 2F ;

Figure 4 is a block diagram schematically illustrating a second  
25 embodiment of a driving principle of the intaglio printing press of Figures 2A to 2F ;

Figure 5 is a block diagram schematically illustrating a third embodiment of a driving principle of the intaglio printing press of Figures 2A to 2F ;

Figure 6 is a block diagram schematically illustrating a first embodiment  
30 of a correcting and adjusting system for the intaglio printing press of Figures 2A to 2F ; and

Figure 7 is a block diagram schematically illustrating a second embodiment of a correcting and adjusting system for the intaglio printing press of Figures 2A to 2F.

#### DETAILED DESCRIPTION OF EMBODIMENTS OF THE INVENTION

Within the scope of the present invention, the expression “intaglio printing  
5 cylinder” shall be understood to be designating a cylinder used for intaglio printing (especially for printing security documents such as banknotes) with at least one intaglio printing medium on its circumference. This encompasses either a cylinder with engraved intaglio patterns on its circumference or a plate cylinder carrying at least one intaglio printing plate on its circumference. In the  
10 following description, the intaglio printing cylinder is a plate cylinder carrying several intaglio printing plates on its circumference.

Similarly the expression “ink-collecting cylinder” shall be understood as being interchangeable with the expression “Orlof cylinder”, which expression is typically used in the art of intaglio printing. The same applies to the expression  
15 “colour-selector cylinder” which shall be understood as being interchangeable with the expression “chablon cylinder”, which latter expression is also used in the art of intaglio printing.

The invention will be described hereinafter with reference to a preferred embodiment where the intaglio printing press comprises at least a first mobile  
20 carriage supporting the ink-collecting cylinder. It is however to be understood that the invention is equally applicable in the case where the ink-collecting cylinder is located in the stationary machine frame.

Figure 2A illustrates a preferred embodiment of an intaglio printing press according to the invention. The various components of the press are shown  
25 here in their working positions, i.e. for carrying out printing operations. As shown, the intaglio printing press comprises a stationary machine frame 01 supporting an intaglio printing cylinder 07 and an impression cylinder 06 which contacts the intaglio printing cylinder 07. In this example, during printing operations, individual sheets are typically fed to the circumference of the  
30 impression cylinder 06 which then carries the sheets one after the other to the printing nip between the impression cylinder 06 and the intaglio printing cylinder

07 where the sheets are printed. Once printed, the sheets are then taken away from the circumference of the impression cylinder 06 by a suitable sheet delivery system which may typically comprise an endless chain gripper system 09 cooperating with the impression cylinder 06 downstream of the printing nip as schematically illustrated.

As illustrated, the stationary machine frame 01 further supports a wiping system for wiping the inked surface of the intaglio printing cylinder 07 prior to printing as is typical in the art. In the illustrated example, such wiping system comprises a wiping roller assembly 10 contacting the surface of the intaglio printing cylinder 07, which assembly includes a wiping roller that is caused to rotate in the same direction as the intaglio printing cylinder 07 (i.e. in the counter-clockwise direction in Figure 2A). The direction of rotation of each cylinder or drum of the intaglio printing press is indicated in Figure 2A by corresponding arrows.

The intaglio printing press is of the type comprising an inking system having an ink-collecting cylinder 12 (or "Orlof cylinder") which contacts the intaglio printing cylinder 07 and collects the inks of different colours provided by a plurality of associated inking devices 13, 16 before transferring the resulting multicolour pattern of inks to the circumference of the intaglio printing cylinder 07.

In this preferred example, the intaglio printing press comprises two mobile carriages 11, 14. The first mobile carriage 11 supports the ink-collecting cylinder 12 and a plurality of (at least four, preferably five as illustrated) colour-selector cylinders 13. The second mobile carriage 14 supports a corresponding number of (i.e. five in this example) inking units 16 each cooperating with a corresponding one of the colour-selector cylinders 13 that are supported in the first mobile carriage 11. Both mobile carriages can be moved horizontally and are suspended under suspension rails 04. In this way, both mobile carriages 11, 14 can be moved above the floor part 02 onto which the printing press is installed along a direction indicated by arrow A in Figure 2A.

While the preferred embodiment includes two mobile carriages, it should be understood that the present invention is also applicable in the case where

the printing press would only comprise one mobile carriage supporting the ink-collecting cylinder 12 and the associated inking devices 13, 16. More than two mobile carriages may also be envisaged.

Figures 2B to 2F illustrate various positions in which the mobile carriages  
5 11, 14 may be brought during maintenance operations of the above-described intaglio printing press.

As mentioned, and illustrated in Figure 2B, both mobile carriages 11, 14  
may be retracted along a horizontal direction indicated by arrow A away from  
the stationary machine frame 01. The first and second mobile carriages 11, 14  
10 can be moved independently of one another by means of corresponding  
carriage drives 40, 45 (not illustrated in Figures 2A to 2F – see Figures 3 to 5).  
If one only needs to carry out maintenance operations on the inking units 16  
and the colour-selector cylinders 13, one may simply retract the second mobile  
carriage 14 away from the first mobile carriage 11 to create sufficient space for  
15 a human operator between the two mobile carriages 11, 14.

In the position illustrated in Figure 2B, the second mobile carriage 14 has  
been moved to its retracted position, while the first mobile carriage 11 that  
supports the ink-collecting cylinder 12 and the colour-selector cylinders 13 is in  
the process of being retracted away from the stationary machine frame 01. In  
20 this position, the ink-collecting cylinder 12 does not contact the intaglio printing  
cylinder 07 anymore.

Once the first mobile carriage 11 is moved to its retracted position (which  
could be a position as illustrated in Figure 2C or a position closer to – or even  
contacting – the second mobile carriage 14), the ink-collecting cylinder 12 may  
25 be rotated by the human operator (as illustrated by the arrow B in Figure 2C).  
Such rotation of the ink-collecting cylinder 12 would in particular be carried out  
in case one needs to replace the blankets that are typically mounted on the ink-  
collecting cylinder 12.

Once the maintenance operations have been carried out, the first mobile  
30 carriage 11 may be moved back towards the stationary machine frame 01 as  
illustrated by arrow C in Figure 2D. In this Figure, it may be appreciated that the  
ink-collecting cylinder 12 is still in the same rotational position as in Figure 2C,

which rotational position is distinct from the one illustrated in Figures 2A and 2B. This rotational position of the ink-collecting cylinder 12 would be improper as it does not match with the position illustrated in Figures 2A and 2B that is necessary to properly cooperate with the intaglio printing cylinder 07.

5 Therefore, before coupling the first mobile carriage 11 with the stationary machine frame 01 (or upon coupling of the first mobile carriage 11 with the stationary machine frame 01), the rotational position of the ink-collecting cylinder 12 is corrected and adjusted with respect to the rotational position of the intaglio printing cylinder 07 to ensure proper circumferential register  
10 between the ink-collecting cylinder 12 and the intaglio printing cylinder 07. This is carried out by means of an adequate correcting and adjusting system that will be described hereafter, which system enables the ink-collecting cylinder 12 to be rotated to the appropriate position as illustrated by arrow D in Figure 2E.

Once these corrections and adjustments have been carried out, the first  
15 mobile carriage 11 can be coupled to the machine frame 01 and interlocked therewith and the second mobile carriage 14 can be moved back towards the first mobile carriage 11 along arrow C as illustrated in Figure 2F.

Turning back to Figure 2A, one may further appreciate that the configuration of the intaglio printing press according to this preferred  
20 embodiment exhibits various additional features that are particularly advantageous.

Firstly, it may be appreciated that the axis of rotation of the ink-collecting cylinder 12 lies below a horizontal plane P0 intersecting the axis of rotation of the intaglio printing cylinder 07, which configuration allows to reduce the  
25 machine footprint as compared for instance to the known configuration disclosed in International Application No. WO 03/047862 A1. More precisely, the first mobile carriage 11 is moveable along the horizontal plane P0 and a plane P2 intersecting the axis of rotation of the ink-collecting cylinder 12 and the axis of rotation of the intaglio printing cylinder 07 forms, in the working position,  
30 an acute angle  $\beta$  with respect to the horizontal plane P0.

In the illustrated example, the intaglio printing cylinder 07 is a three-segment plate cylinder carrying three intaglio printing plates. The corresponding

cylinder pits on the intaglio printing cylinder (shown in Figure 2A but not designated by any reference numeral) are accordingly distributed at angular intervals of  $120^\circ$ . Advantageously, the plane P2 intersecting the axis of rotation of the ink-collecting cylinder 12 and the axis of rotation of the intaglio printing cylinder 07 forms, in the working position, an obtuse angle  $\alpha$  of  $120^\circ$  with respect to a plane P1 intersecting the axis of rotation of the impression cylinder 06 and the axis of rotation of the intaglio printing cylinder 07. One ensures in this way that the cylinder pits of the impression cylinder 06, of the intaglio printing cylinder 07 and of the ink-collecting cylinder 12 always meet at the same time, thereby preventing vibrations and shocks resulting from the meeting of the cylinder pits from having any influence on the printing and inking operations.

The wiping roller assembly 10 is preferably located in a similar way with respect to the intaglio printing cylinder 07, namely in such a way that a plane P3 intersecting the axis of rotation of the wiping roller assembly 10 and the axis of rotation of the intaglio printing cylinder 07 forms an obtuse angle  $\gamma$  of  $120^\circ$  with respect to the plane P1 intersecting the axis of rotation of the impression cylinder 06 and the axis of rotation of the intaglio printing cylinder 07.

Preferably, in this configuration, the acute angle  $\beta$  with respect to the horizontal plane P0 is selected to be lower or equal to  $30^\circ$ , even more preferably comprised between  $10^\circ$  and  $25^\circ$ .

One may further appreciate that the ink-collecting cylinder 12, the impression cylinder 06 and the intaglio printing cylinder 07 all have the same diameter (and are therefore triple-sized cylinders), meaning that the same sections of cylinders 06, 07, 12 always cooperate with one another.

One may also note that, in the preferred embodiment shown in Figures 2A to 2F, five colour-selector cylinders 13 are distributed around part of the circumference of the ink-collecting cylinder 12, one (namely the central one) being located in such a way that its axis of rotation lies substantially in the same horizontal plane as the axis of rotation of the ink-collecting cylinder 12. The remaining four colour-selector cylinders 13 are distributed substantially

symmetrically around the ink-collecting cylinder 12 with respect to the horizontal plane intersecting the axis of rotation of the ink-collecting cylinder 12.

The above configuration ensures that space is used in an optimized way to integrate as many inking devices as possible and provide suitable access to every component of the printing press without compromising ease of maintenance and machine footprint. This configuration furthermore leads to an intaglio printing press having as much as possible a compact configuration.

Figure 3 is a block diagram schematically illustrating a first embodiment of a driving principle of the intaglio printing press of figures 2A to 2F. In this example, the intaglio printing comprises a main drive 100 which, during printing operations, drives the intaglio printing cylinder 07, the impression cylinder 06 and the ink-collecting cylinder 12 into rotation via gears (as well as potentially other components, such as the wiping roller assembly 10 and the chain gripper system 09). Such gears include disconnectable gears 50 (schematically illustrated in Figure 3) between the ink-collecting cylinder 12 and the intaglio printing cylinder 07 enabling the driving connection with the ink-collecting cylinder 12 to be interrupted when the mobile carriage 11 is retracted away from the stationary machine frame 01. In this example, since the gears 50 between the ink-collecting cylinder 12 and the intaglio printing cylinder 07 are disconnected upon displacement of the first mobile carriage 11 away from the stationary machine frame 01, a drive system is provided to rotate the ink-collecting cylinder 12 during maintenance operations. As this will be appreciated hereinafter, this drive system further acts as a means for correcting and adjusting a rotational position of the ink-collecting cylinder 12 with respect to a rotational position of the intaglio printing cylinder 07 to ensure proper circumferential register between the ink-collecting cylinder 12 and the intaglio printing cylinder 07.

In the example of Figure 3, the drive system comprises an auxiliary drive 110, such as a servo motor, for rotating the ink-collecting cylinder 12 when the mobile carriage 11 is uncoupled from the stationary machine frame 01.

Assuming that the colour-selector cylinders 13 are driven into rotation together with the ink-collecting cylinder 12, rotation of the colour-selector

cylinder 13 during maintenance operations may be carried out using the same auxiliary drive 110. One may however envisage providing one or more additional auxiliary drive(s) to drive the colour-selector cylinders 13 into rotation during maintenance operations.

5           In the example of Figure 3, disconnectable gears 55 are also provided between the first and second mobile carriages 11, 14, such gears 55 being disconnected upon displacement of the second mobile carriage 14 away from the first mobile carriage 11. Optionally, one or more additional auxiliary drive(s) 140 may be provided to drive the inking units 16 during maintenance operations  
10 when the second mobile carriage 14 is uncoupled from the first mobile carriage 11.

As the first and second mobile carriages 11, 14 are moved in an independent manner, two separate carriage drives 40, 45 are provided to drive the carriages 11, 14, respectively, along the suspension rails 04.

15           The auxiliary drive 110 of Figure 3 could also be used in a variant of the invention where the ink-collecting cylinder 12 would be located in the stationary machine frame 01 and driven into rotation, during printing operations, by the main drive 100 of the intaglio printing press. In such case, a mechanism would further be provided to allow a contact pressure between the intaglio printing  
20 cylinder 07 and the ink-collecting cylinder 12 to be interrupted during maintenance operations. Furthermore, a clutch system would be provided to allow the ink-collecting cylinder 12 to be rotated by the auxiliary drive 110 during maintenance operations independently of the intaglio printing cylinder 07.

A possible variant of the driving principle of Figure 3 is illustrated in  
25 Figure 4. In this other example, rather than having the main drive 100 drive the ink-collecting cylinder 12 during printing operations, at least one independent drive 115 is provided to drive the ink-collecting cylinder 12 into rotation, independently of the intaglio printing cylinder 07 and impression cylinder 06. Such independent drive 115 is adapted to rotate the ink-collecting cylinder 12 at  
30 high speed and in phase synchronism with the intaglio printing cylinder 07 during printing operations. In this way, one may do without the disconnectable gears 50 of Figure 3 and the said independent drive 115 can be used as the

drive system for rotating the ink-collecting cylinder 12 both during printing operations and during maintenance operations. Such independent drive 115 can further be used as the means to correct and adjust the rotational position of the ink-collecting cylinder 12 when the first mobile carriage 11 is uncoupled  
5 from the stationary machine frame 01.

Once again, assuming that the colour-selector cylinders 13 are driven into rotation together with the ink-collecting cylinder 12, rotation of the colour-selector cylinder 13 during maintenance operations may be carried out using the same independent drive 115. One may however envisage providing one or  
10 more additional independent drive(s) to drive the colour-selector cylinders 13 into rotation during maintenance operations.

In the example of Figure 4, disconnectable gears 55 are still provided between the first and second mobile carriages 11 and 14 (as in Figure 3). In this case, one or more auxiliary drive(s) 140 may optionally be provided to drive the  
15 inking units 16 during maintenance operations if necessary. It will however be understood that it is perfectly possible to do without any disconnectable gears at all and use one or more independent drive(s) to drive the inking units both during printing operations and maintenance operations.

Yet another variant of the driving principles of Figures 3 and 4 is  
20 illustrated in Figure 5. In this example, the main drive 100 is used to drive the components of the printing unit including the intaglio printing cylinder 07 and the impression cylinder 06 and various independent drives are used to drive the remaining components of the press, namely:

- i. one independent drive 116 for driving the ink-collecting cylinder 12  
25 into rotation ;
- ii. a plurality (e.g. five) of independent drives 117 for driving the colour-selector cylinders 13 located in the first mobile carriage 11 ; and
- iii. one or more independent drives 145 for driving the inking units 16 located in the second mobile carriage 14.

30 In this way, no disconnectable gear arrangement is necessary between the first mobile carriage 11 and the stationary machine frame 01 or between the second mobile carriage 14 and the first mobile carriage 11.

The independent drive 115 or 116 of Figures 4 and 5 could also be used in a variant of the invention where the ink-collecting cylinder 12 would be located in the stationary machine frame 01. In such case, a mechanism would further be provided to allow a contact pressure between the intaglio printing cylinder 07 and the ink-collecting cylinder 12 to be interrupted during maintenance operations. No clutch system would be necessary in this case.

Various types of motors may be used as auxiliary drives or independent drives in the examples of Figures 3 to 5. So-called torque motors may especially be used as independent drive for the ink-collecting cylinder in the examples of Figures 4 and 5. A simple servo motor may suffice in the example of Figure 3 where such drive is only necessary during maintenance operations to rotate the ink-collecting cylinder 12 at low speed.

A possible configuration of the correcting and adjusting system is illustrated in Figure 6 where the said system is generally designated by reference numeral 80. The system shown in Figure 6 is suitable for use in connection with the driving principle illustrated in Figure 3. It essentially consists of a processing unit 30 that receives data regarding the rotational position of the ink-collecting cylinder 12 and of the intaglio printing cylinder 07. Such data may be provided by means of suitable rotational sensors, such as rotary encoders, measuring the rotational position of each cylinder 07, 12.

A suitable user interface 20 coupled to the processing unit 30 is provided to enable a human operator to control operations of the printing press, especially movement of the carriages 11, 14 towards and/or away from the stationary machine frame 01. The processing unit 30 is coupled to the carriage drive 40 and the auxiliary drive(s) 110 of the first carriage 11 and, whenever necessary or appropriate, to the main drive 100 as well. While this is not specifically illustrated in Figure 6, the processing unit 30 is or may also be coupled to the carriage drive 45 and optional auxiliary drive(s) 140 of the second carriage 14 (not shown in Figure 6).

A human operator may switch the printing press into a maintenance mode by using the user interface 20 and first causing the processing unit 30 to stop the main drive 100. Once the printing press is stopped, the processing unit

30 may read the current rotational position of the intaglio printing cylinder 07 and store it in a suitable memory (not illustrated) for the subsequent correction and adjustment process.

Then, the processing unit 30 may control the first carriage drive 40 (and  
5 the second carriage drive 45 not illustrated in Figure 6) to cause retraction of the first mobile carriage 11 (and second mobile carriage 14 also not illustrated in Figure 6) as illustrated in Figure 2B.

The human operator may then further interact with the user interface 20 to cause the processing unit 30 to control the auxiliary drive(s) 110 and rotate  
10 the ink-collecting cylinder 12 during maintenance operations (for instance in order to exchange the blankets) as illustrated in Figure 2C.

Once the maintenance operations have been carried out, the human operator may again interact with the user interface 20 to cause the first mobile carriage 11 to be moved back to its working position as illustrated in Figure 2D.  
15 Before coupling of the first mobile carriage 11 with the stationary machine frame 01 (or upon coupling thereof), the processing unit 30 reads the current rotational position of the ink-collecting cylinder 12 and compares it with the rotational position of the intaglio printing cylinder 07. Whenever necessary, the processing unit 30 then issues suitable correction and adjustment signals to the auxiliary  
20 drive(s) 110 to correct and adjust the rotational position of the ink-collecting cylinder 12 until it matches the position required to ensure proper circumferential register between the ink-collecting cylinder 12 and the intaglio printing cylinder 07, as illustrated in Figure 2E.

A variant of the correcting and adjusting system 80 is illustrated in Figure  
25 7, which variant is suitable for use in connection with the driving principle illustrated in Figure 5. The general configuration of the system shown in Figure 7 is similar to that of Figure 6, except that the processing unit 30 controls the rotational position of the ink-collecting cylinder 12 separately from that of the colour-selector cylinders 13, there being an independent drive 116 for driving  
30 the ink-collecting cylinder 12 and independent drives 117 for driving the colour-selector cylinders 13. In this example, the correcting and adjusting system 80 is used to control both the rotational position of the ink-collecting cylinder 12 and

the rotational positions of the colour-selector cylinder 13 to ensure proper circumferential register thereof with respect to the intaglio printing cylinder 07.

In the above-described embodiments of the invention, the auxiliary drive 110 or independent drive 115 or 116 that is used to rotate the ink-collecting cylinder 12 can advantageously further act as a means to rotate the ink-collecting cylinder 12 during cleaning operations. Such cleaning operations could be carried out manually by an operator while the ink-collecting cylinder 12 is rotated or automatically. In particular, the intaglio printing press can further comprise an automatic washing device which can selectively be brought into contact with the ink-collecting cylinder 12 during cleaning operations so as to clean the circumference of the ink-collecting cylinder 12. Such washing device is not shown in the Figures as it is known as such in the art, for instance from German Patent Publications Nos. DE 100 27 022 A1 and DE 100 27 023 A1 (other washing devices being however possible).

According to a further variant of the invention, a circumferential speed of each colour-selector cylinder 13 can be changed or adjusted during printing operations with respect to a circumferential speed of the ink-collecting cylinder 12. This can for instance be performed using a corresponding independent drive of the colour-selector cylinder 13 (as provided in the driving principle of Figure 5) as taught in International Application No. WO 2004/069538 A2.

Various modifications and/or improvements may be made to the above-described embodiments without departing from the scope of the invention as defined by the annexed claims. For instance, various adaptations to the configuration and operation of the correcting and adjusting system 80 may be made as long as the system is designed to perform its essential purpose, namely to correct and adjust a rotational position of the ink-collecting cylinder 12 with respect to a rotational position of the intaglio printing cylinder 07 to ensure proper circumferential register between the ink-collecting cylinder 12 and the intaglio printing cylinder 07. Furthermore, the actual configuration of the correcting and adjusting system 80 will depend on the actual driving principle being used, especially whether the ink-collecting cylinder is normally driven into rotation, during printing operations, by the main drive (thus necessitating an

auxiliary drive for the maintenance operations as well as the correcting/adjusting operations) or whether the ink-collecting cylinder is driven into rotation, during printing operations, by an independent drive (in which case this same independent drive may be used during the maintenance operations  
5 as well as the correcting/adjusting operations).

Although the embodiment of the intaglio printing press which has been described in reference to the Figures comprises two mobile carriages, the concept of the invention remains valid for any other printing press configuration of the type comprising an ink-collecting cylinder.

10 The intaglio printing press that has been discussed with reference to the Figures exhibits a cylinder configuration wherein the ink-collecting cylinder 12, the intaglio printing cylinder 07 and impression cylinder 06 are all triple-sized cylinder which form an angle of  $120^\circ$ . Any other cylinder configuration can however be envisaged, with cylinders of different sizes and/or different cylinder  
15 configurations and orientations.

LIST OF REFERENCES USED IN THE FIGURES AND SPECIFICATION

	01	machine frame (stationary)
	02	floor
	03	upright
	04	suspension rails
5	06	impression cylinder (three-segment cylinder)
	07	intaglio printing cylinder / plate cylinder (three-segment cylinder)
	08	sheet grippers
	09	endless chain gripper system
	10	wiping roller assembly
10	11	first mobile carriage
	12	ink-collecting cylinder / Orlof cylinder (three-segment cylinder)
	13	colour-selector cylinders / chablon cylinders (one-segment cylinder)
	14	second mobile carriage
15	16	inking units
	17	first working space (between first and second mobile carriages 11, 14)
	18	second working space (between first mobile carriage 11 and machine frame 01)
20	20	user interface / central console
	30	processing unit for circumferential register control and adjustment
	40	carriage drive (first mobile carriage 11)
	45	carriage drive (second mobile carriage 14)
25	50	disconnectable gears (between ink-collecting cylinder 12 and intaglio printing cylinder 07)
	55	disconnectable gears (between ink-collecting cylinder 12, colour-selector cylinders 13 and inking units 16)
	80	correcting and adjusting system
	100	main drive
30	110	auxiliary drive(s) for ink-collecting cylinder 12 and colour-selector cylinders 13

- 115 independent drive(s) for ink-collecting cylinder 12 and colour-selector cylinders 13
- 116 independent drive for ink-collecting cylinder 12
- 117 independent drives for colour-selector cylinders 13
- 5 140 auxiliary drive(s) for inking units 16
- 145 independent drive(s) for inking units 16
- P0 horizontal plane intersecting axis of intaglio printing cylinder 07
- P1 plane intersecting axis of rotation of impression cylinder 06 and axis of rotation of intaglio printing cylinder 07
- 10 P2 plane intersecting axis of rotation of ink-collecting cylinder 12 and axis of rotation of intaglio printing cylinder 07
- P3 plane intersecting axis of rotation of intaglio printing cylinder 07 and axis of rotation of wiping roller assembly 10
- $\alpha$  obtuse angle between planes P1 and P2
- 15  $\beta$  acute angle between planes P0 and P2
- $\gamma$  obtuse angle between planes P1 and P3
- A displacement of mobile carriages 12, 14 from working position to retracted position (Figures 2A and 2B)
- B rotation of ink-collecting cylinder 12 during maintenance operations (Figure 2C)
- 20 C displacement of mobile carriages 12, 14 from retracted position to working position (Figures 2D and 2F)
- D rotation of ink-collecting cylinder 12 during circumferential register correction and adjustment (Figure 2E)

CLAIMS

1. An intaglio printing press comprising :
  - a stationary machine frame (01) supporting an intaglio printing cylinder (07) and an impression cylinder (06) contacting said intaglio printing cylinder (07) ; and
  - 5 - an inking system (12, 13, 16) for inking the intaglio printing cylinder (07), which inking system (12, 13, 16) comprises an ink-collecting cylinder (12) designed to contact said intaglio printing cylinder (07) and at least one inking device (13, 16) for supplying ink to said ink-collecting cylinder (12),  
wherein said intaglio printing press further comprises a drive system  
10 (110; 115; 116) for rotating said ink-collecting cylinder (12) independently of said intaglio printing cylinder (07) and said impression cylinder (06) at least during maintenance operations.
2. The intaglio printing press as defined in claim 1, further comprising  
15 a main drive (100) which, during printing operations, drives the intaglio printing cylinder (07), impression cylinder (06) and ink-collecting cylinder (12) into rotation via gears, wherein said drive system comprises an auxiliary drive (110) for rotating the ink-collecting cylinder (12) during maintenance operations.
- 20 3. The intaglio printing press as defined in claim 2, wherein the auxiliary drive (110) is adapted to rotate the ink-collecting cylinder (12) at low speed.
4. The intaglio printing press as defined in claim 2 or 3, wherein the  
25 auxiliary drive (110) is a servo motor.
5. The intaglio printing press as defined in claim 1, wherein said drive system comprises an independent drive (115; 116) for rotating the ink-collecting cylinder (12) both during printing operations and during maintenance  
30 operations.

6. The intaglio printing press as defined in claim 5, wherein the independent drive (115; 116) is adapted to rotate the ink-collecting cylinder (12) at high speed and in phase synchronism with the intaglio printing cylinder (07) during printing operations.

5

7. The intaglio printing press as defined in claim 5 or 6, wherein the independent drive (115; 116) is a torque motor.

8. The intaglio printing press as defined in any one of the preceding  
10 claims, wherein the drive system (110; 115; 116) used for rotating the ink-collecting cylinder (12) further acts as a means to rotate the ink-collecting cylinder (12) during cleaning operations.

9. The intaglio printing press as defined in claim 8, further comprising  
15 an automatic washing device which can selectively be brought into contact with the ink-collecting cylinder (12) during cleaning operations so as to clean the circumference of the ink-collecting cylinder (12).

10. The intaglio printing press as defined in any one of the preceding  
20 claims, further comprising at least a first mobile carriage (11) supporting said ink-collecting cylinder (12), which first mobile carriage (11) is adapted to be moved with respect to said stationary machine frame (01) between a working position where the ink-collecting cylinder (12) contacts the intaglio printing cylinder (07) and a retracted position where the ink-collecting cylinder (12) is  
25 retracted away from the intaglio printing cylinder (07).

11. The intaglio printing press as defined in claims 2 and 10, wherein  
gears (50) between the ink-collecting cylinder (12) and the intaglio printing  
cylinder (07) are disconnected upon displacement of the first mobile carriage  
30 (11) away from the stationary machine frame (01).

12. The intaglio printing press as defined in claim 10 or 11, further comprising a correcting and adjusting system (80) for correcting and adjusting a rotational position of the ink-collecting cylinder (12) with respect to a rotational position of the intaglio printing cylinder (07) following maintenance operations to  
5 ensure proper circumferential register between the ink-collecting cylinder (12) and the intaglio printing cylinder (07) in the working position of the first mobile carriage (11) and wherein said drive system (110; 115; 116) is used for correcting/adjusting the rotational position of the ink-collecting cylinder (12).

10 13. The intaglio printing press as defined in any one of claims 10 to 12, wherein said intaglio printing press further comprises a second mobile carriage (14) supporting at least part of said at least one inking device (13; 16), which second mobile carriage (14) is adapted to move with respect to said first mobile carriage (11) between a working position where the second mobile  
15 carriage (14) contacts the first mobile carriage (11) and a retracted position where the second mobile carriage (14) is retracted away from the first mobile carriage (11).

14. The intaglio printing press as defined in any one of claims 10 to  
20 13, wherein said at least one inking device (13, 16) comprises an inking unit (16) and a colour-selector cylinder (13) which is inked by said inking unit (16) and contacts a portion of the circumference of the ink-collecting cylinder (12),  
and wherein said first mobile carriage (11) also supports the colour-selector cylinder (13) of the said at least one inking device (13, 16).

25

15. The intaglio printing press as defined in any one of claims 10 to 14, wherein said first mobile carriage (11) is moveable along a horizontal plane (P0) and wherein a plane (P2) intersecting the axis of rotation of the ink-collecting cylinder (12) and the axis of rotation of the intaglio printing cylinder  
30 (07) forms in the working position an acute angle ( $\beta$ ) with respect to the horizontal plane (P0).

16. The intaglio printing press as defined in any one of the preceding claims, wherein said intaglio printing cylinder (07) is a three-segment plate cylinder carrying three intaglio printing plates,

5 and wherein a plane (P2) intersecting the axis of rotation of the ink-collecting cylinder (12) and the axis of rotation of the intaglio printing cylinder (07) forms, in a position where the ink-collecting cylinder (12) contacts the intaglio printing cylinder (07), an obtuse angle ( $\alpha$ ) of  $120^\circ$  with respect to a plane (P1) intersecting the axis of rotation of the impression cylinder (06) and the axis of rotation of the intaglio printing cylinder (07).

10

17. The intaglio printing press as defined in claim 16, further comprising a wiping system for wiping the inked surface of the intaglio printing cylinder (07),

15 wherein said wiping system comprises a wiping roller assembly (10) contacting the surface of the intaglio printing cylinder (07),

and wherein a plane (P3) intersecting the axis of rotation of the wiping roller assembly (10) and the axis of rotation of the intaglio printing cylinder (07) forms an obtuse angle ( $\gamma$ ) of  $120^\circ$  with respect to the plane (P1) intersecting the axis of rotation of the impression cylinder (06) and the axis of rotation of the  
20 intaglio printing cylinder (07).

18. The intaglio printing press as defined in claim 16 or 17, wherein the axis of rotation of the ink-collecting cylinder (12) lies below a horizontal plane (P0) intersecting the axis of rotation of the intaglio printing cylinder (07).

25

19. The intaglio printing press as defined in claim 18, wherein the plane (P2) intersecting the axis of rotation of the ink-collecting cylinder (12) and the axis of rotation of the intaglio printing cylinder (07) forms, in a position where the ink-collecting cylinder (12) contacts the intaglio printing cylinder (07), an  
30 acute angle ( $\beta$ ) with respect to the horizontal plane (P0).

20. The intaglio printing press as defined in claim 15 or 19, wherein said acute angle ( $\beta$ ) is lower or equal to 30°.

21. The intaglio printing press as defined in claim 20, wherein said acute angle ( $\beta$ ) is comprised between 10° and 25°.

22. The intaglio printing press as defined in any one of the preceding claims, wherein the ink-collecting cylinder (12) has the same diameter as the intaglio printing cylinder (07).

23. The intaglio printing press as defined in any one of the preceding claims, wherein the impression cylinder (06) has the same diameter as the intaglio printing cylinder (07).

24. The intaglio printing press as defined in any one of the preceding claims, wherein said ink-collecting cylinder (12) is a three-segment ink-collecting cylinder and wherein said inking system (12, 13, 16) comprises at least four, preferably five, inking devices (13, 16) distributed about a portion of the circumference of the ink-collecting cylinder (12).

25. The intaglio printing press as defined in any one of the preceding claims, wherein said inking system (12, 13, 16) comprises one or more inking devices (13, 16) distributed about a portion of the circumference of the ink-collecting cylinder (12), each inking device (13, 16) comprising an inking unit (16) and a colour-selector cylinder (13) which is inked by said inking unit (16) and contacts a portion of the circumference of the ink-collecting cylinder (12),

and wherein each colour-selector cylinder (13) can be driven into rotation during maintenance operations by a drive (110; 115; 117).

26. The intaglio printing press as defined in any one of the preceding claims, wherein said inking system (12, 13, 16) comprises one or more inking devices (13, 16) distributed about a portion of the circumference of the ink-

collecting cylinder (12), each inking device (13, 16) comprising an inking unit (16) and a colour-selector cylinder (13) which is inked by said inking unit (16) and contacts a portion of the circumference of the ink-collecting cylinder (12),

and wherein a circumferential speed of each colour-selector cylinder (13)  
5 can be changed or adjusted during printing operations with respect to a circumferential speed of the ink-collecting cylinder (12).

27. A mobile carriage (11) for an intaglio printing press, supporting an ink-collecting cylinder (12) designed to contact an intaglio printing cylinder (07)  
10 which is supported in a stationary machine frame (01) of the intaglio printing press,

wherein said mobile carriage (11) comprises a drive system (110; 115; 116) for rotating said ink-collecting cylinder (12) independently of the intaglio printing cylinder (07) of the intaglio printing press at least during maintenance  
15 operations.

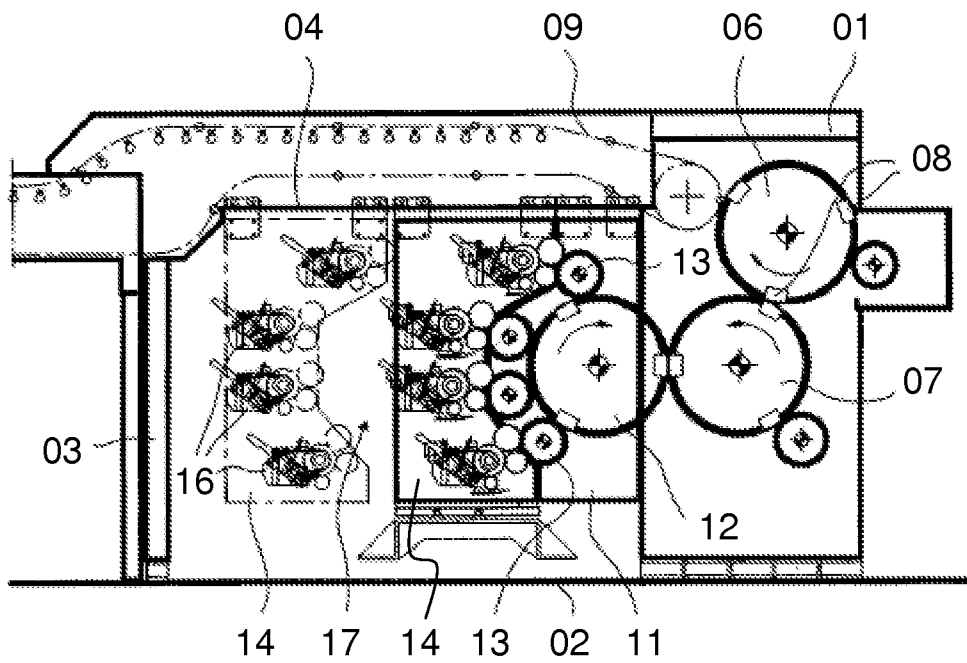

Fig. 1A

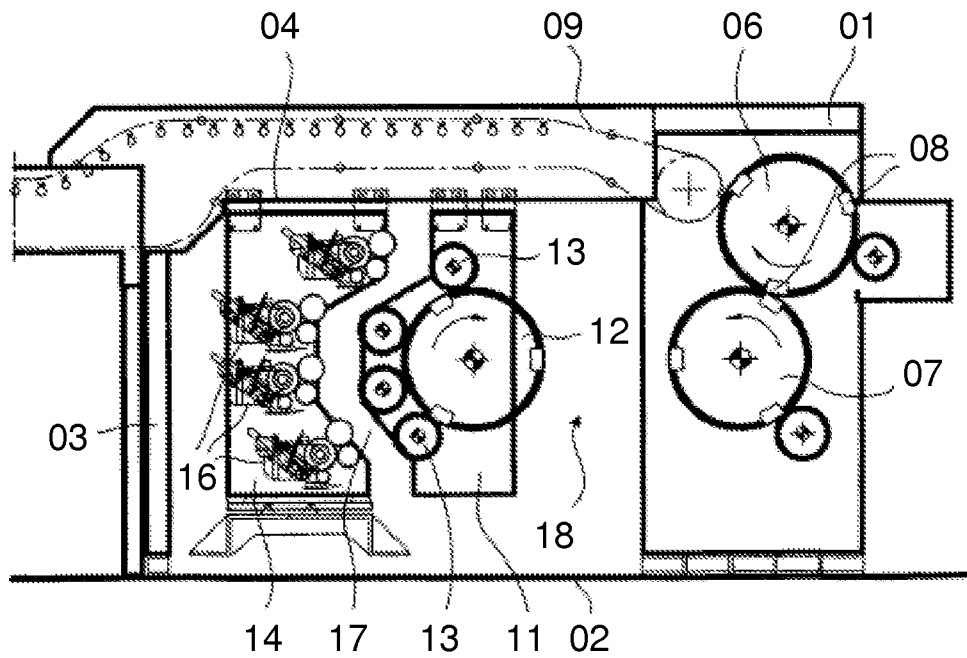

Fig. 1B



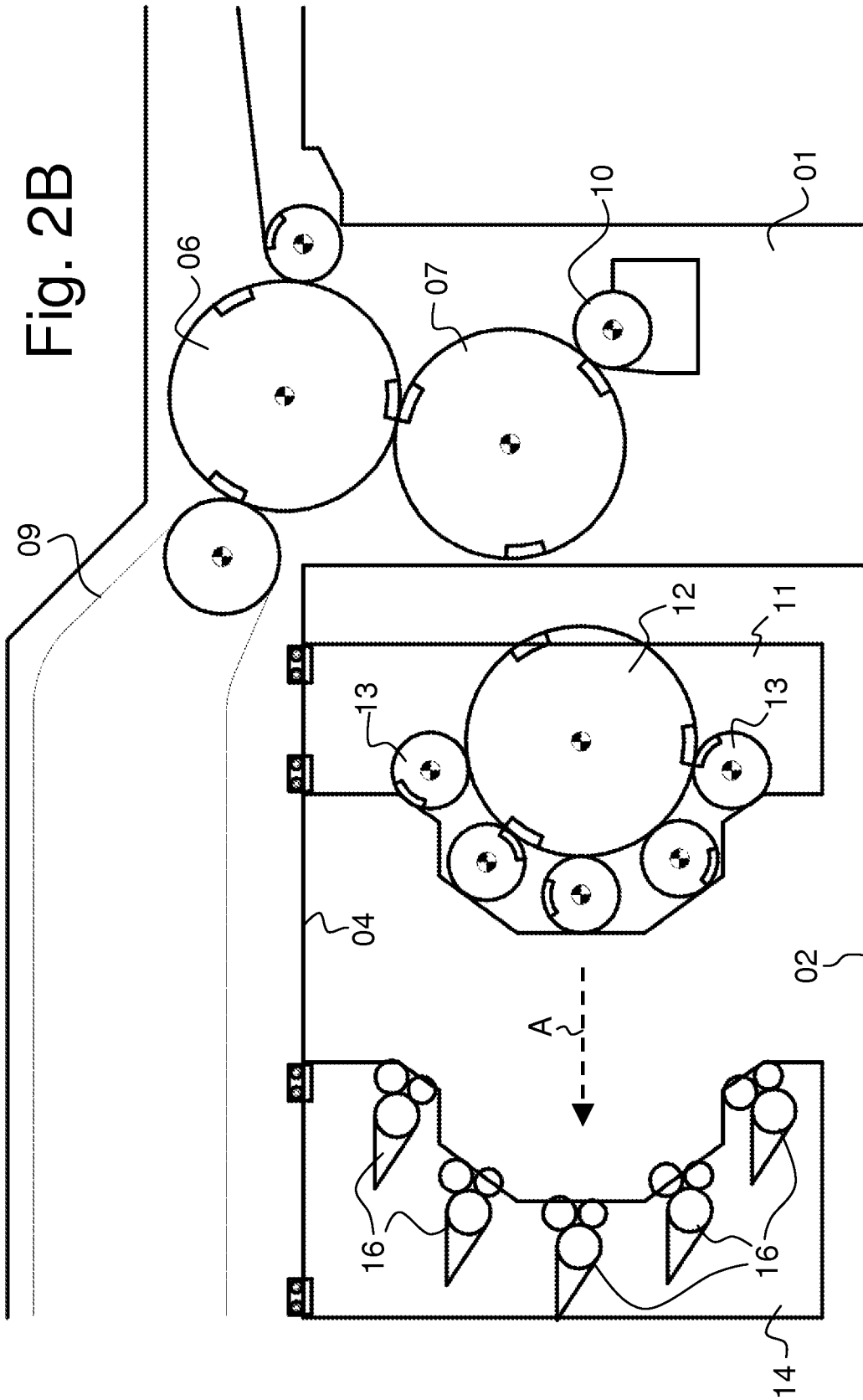

Fig. 2C

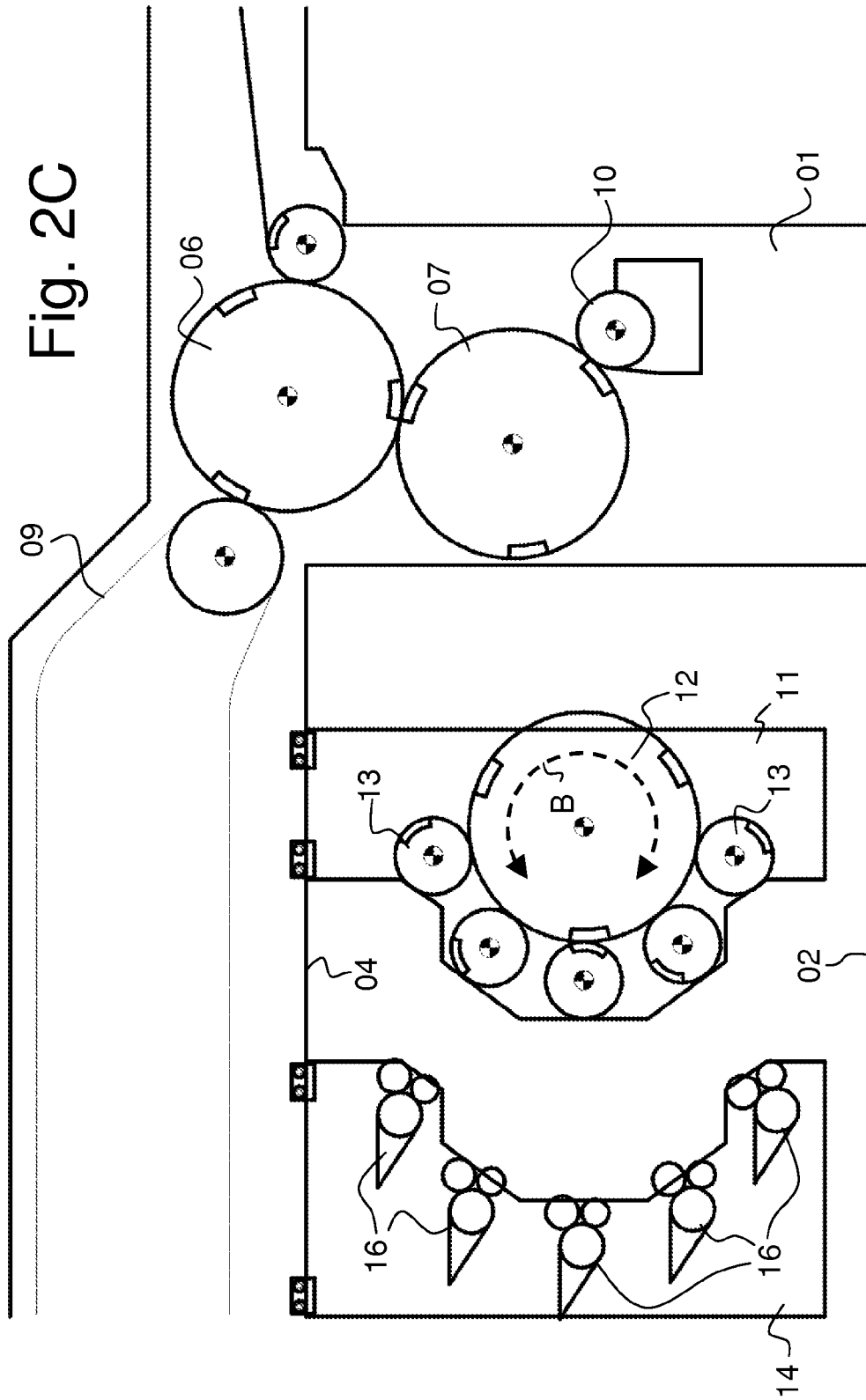

Fig. 2D

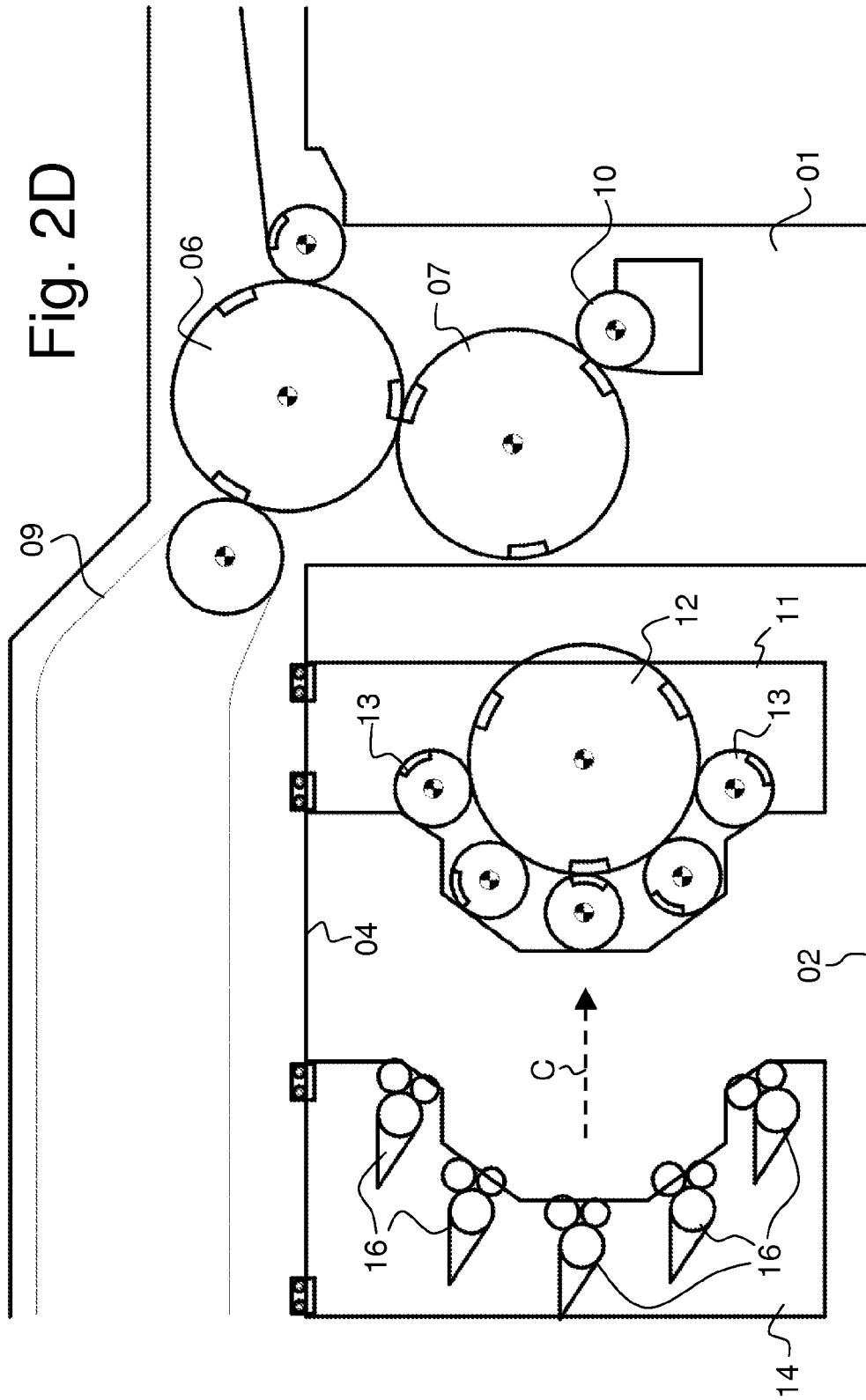

Fig. 2E

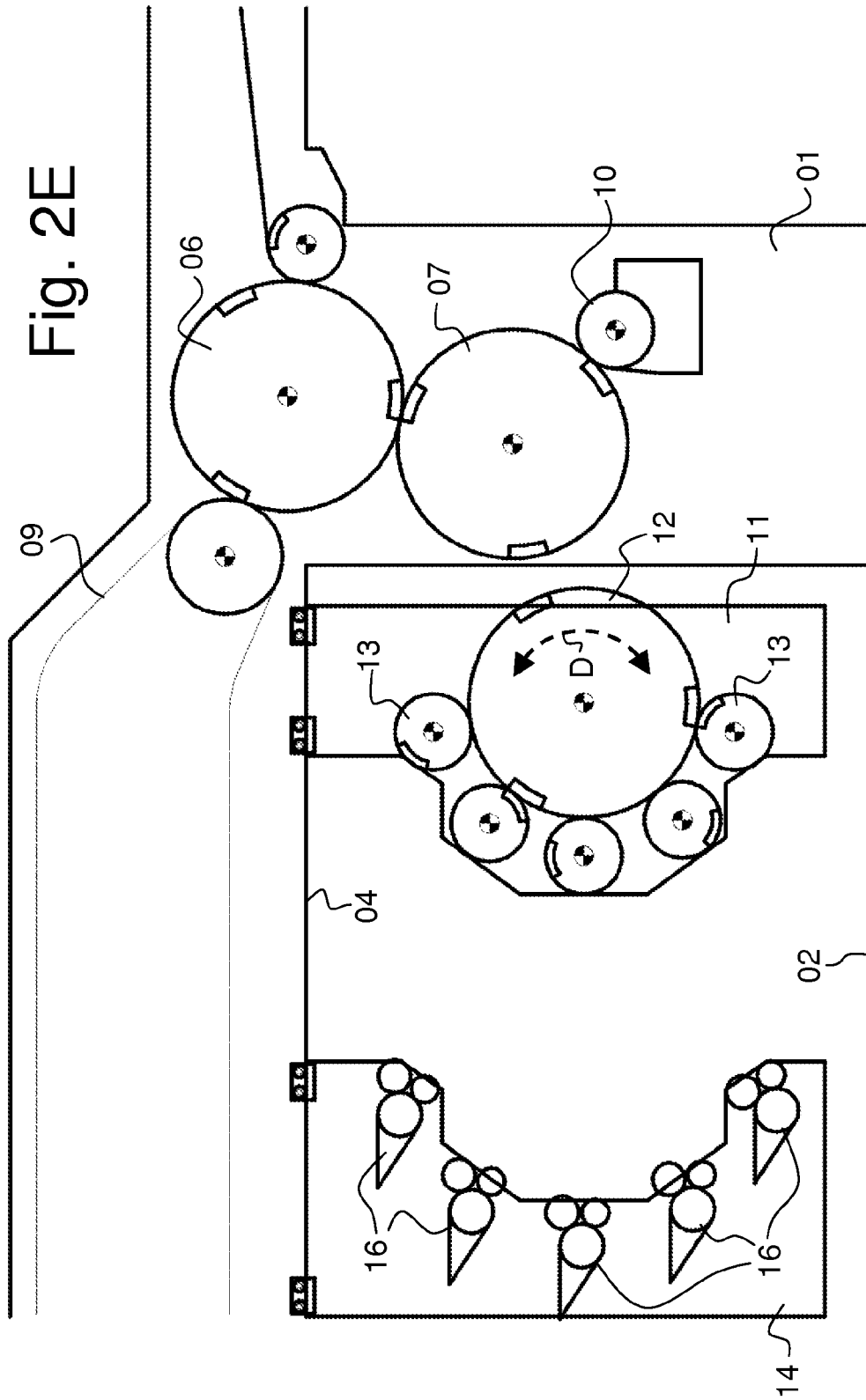
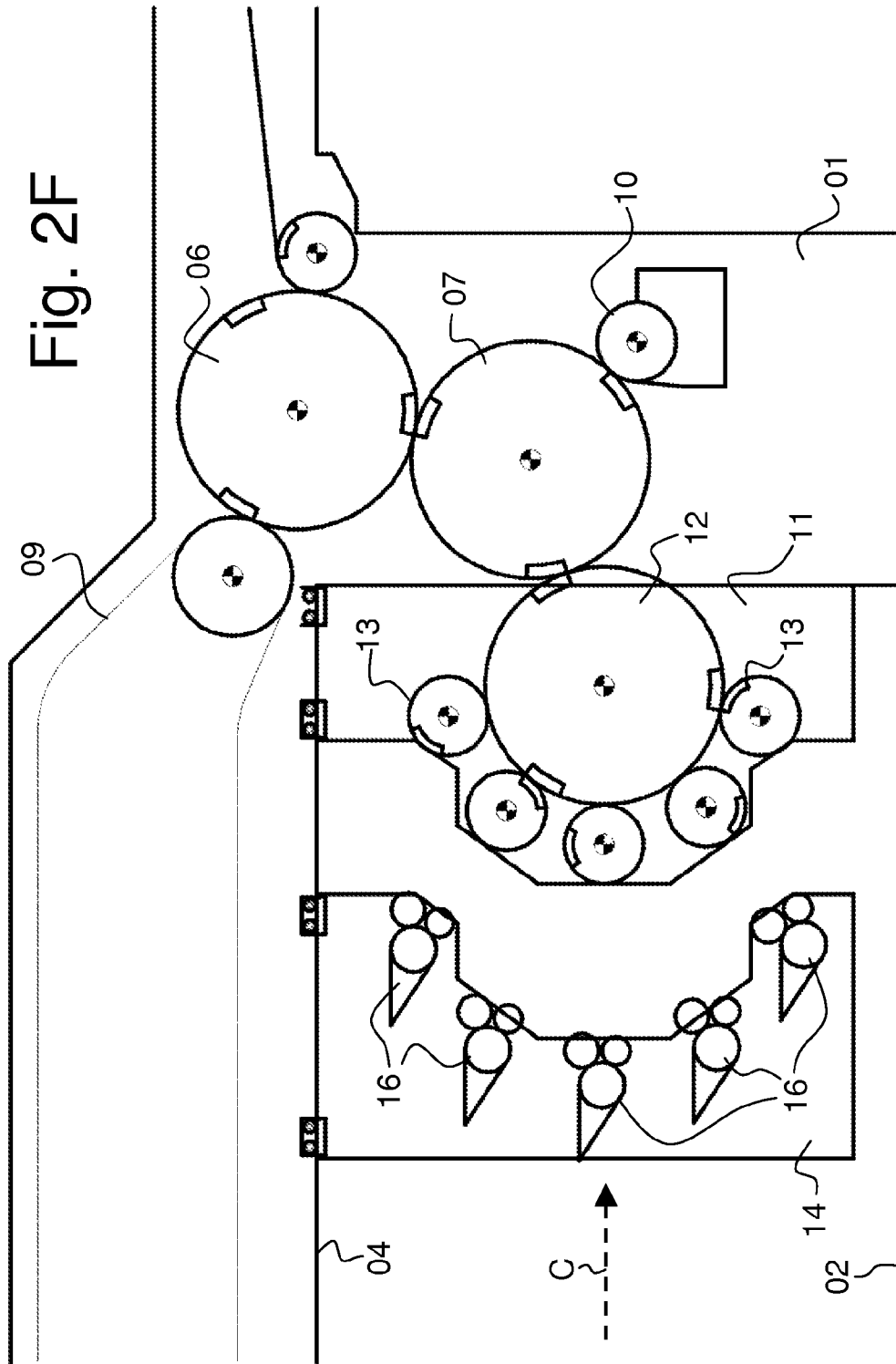

Fig. 2F



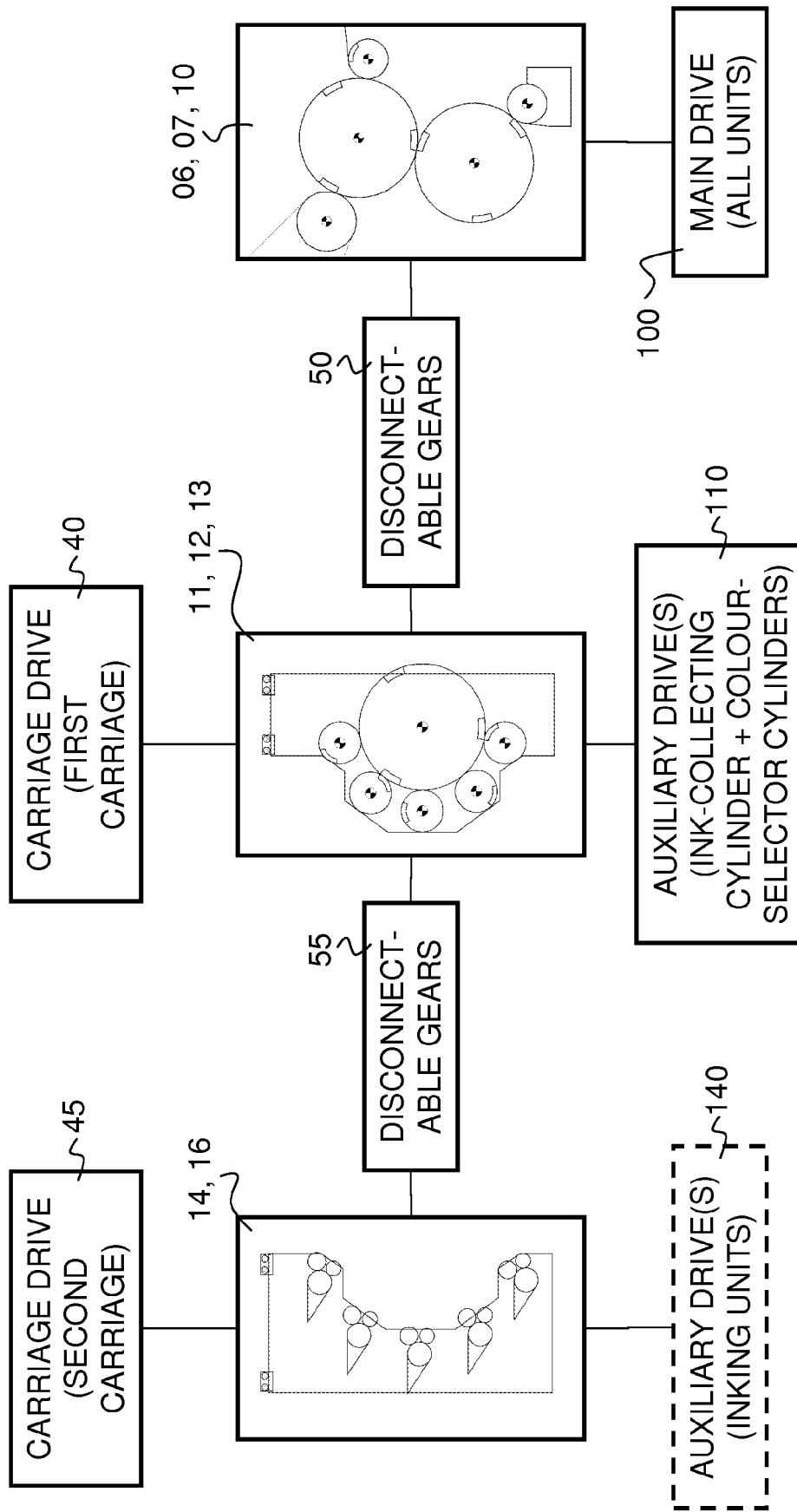

Fig. 3

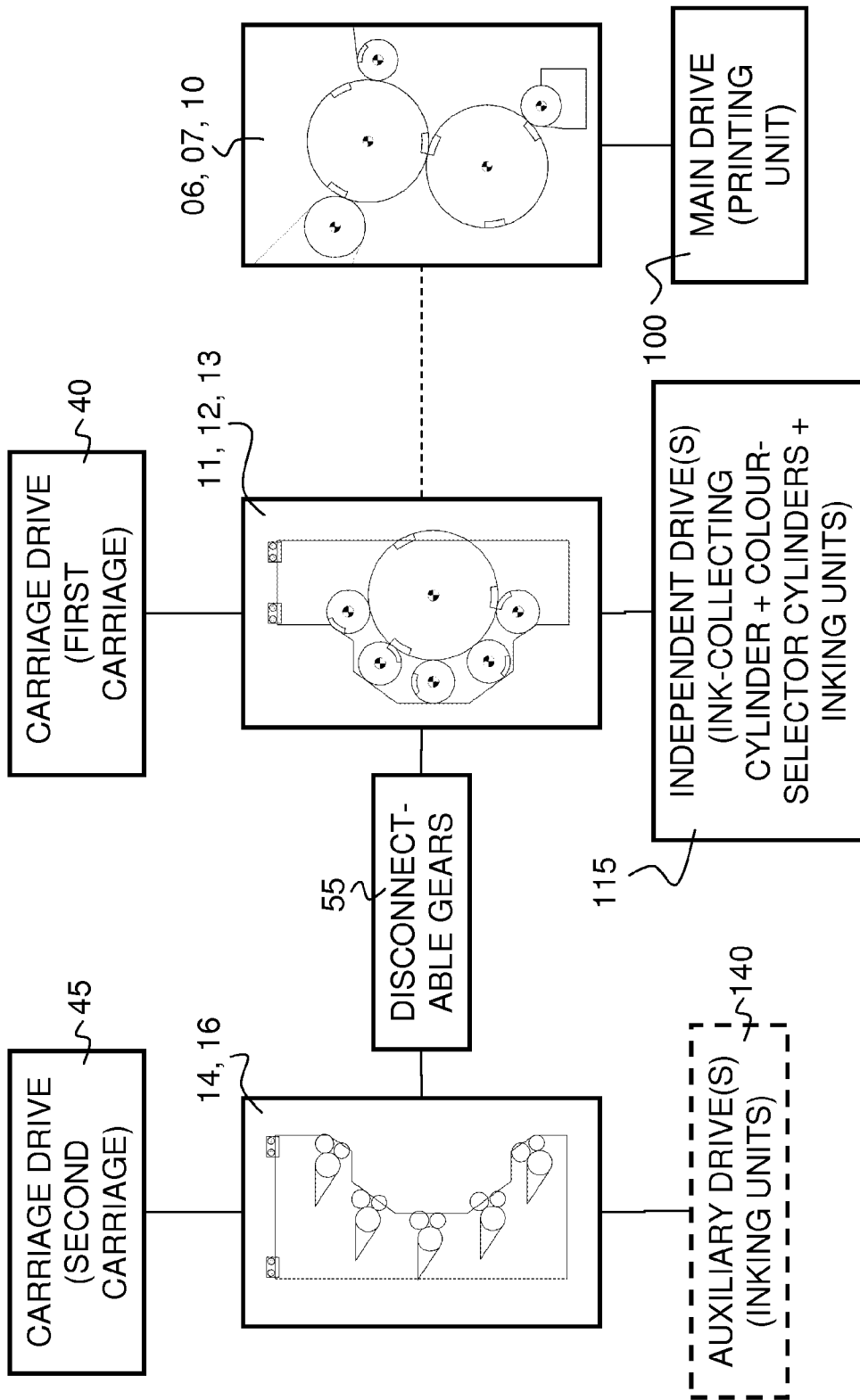

Fig. 4

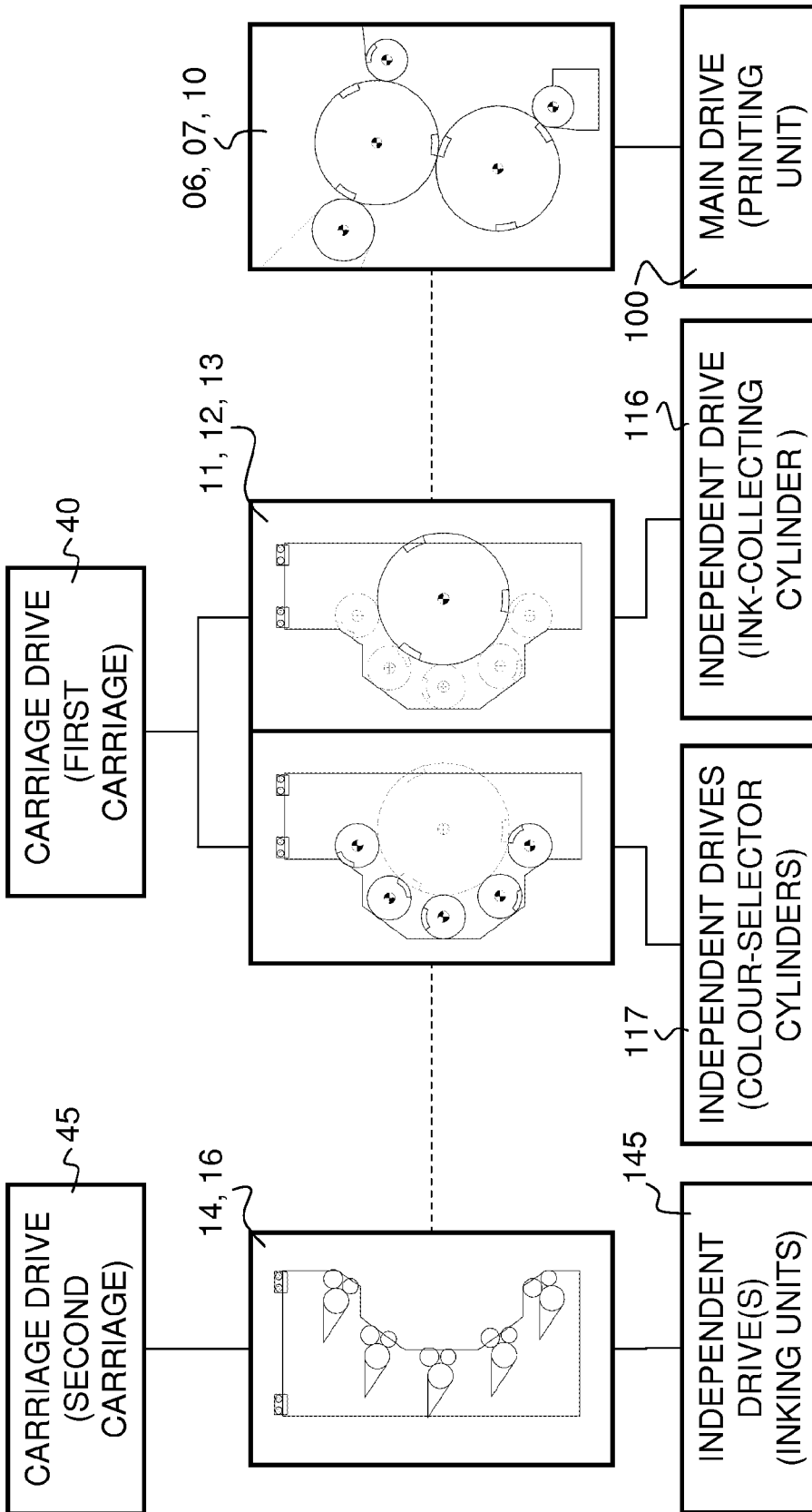

Fig. 5

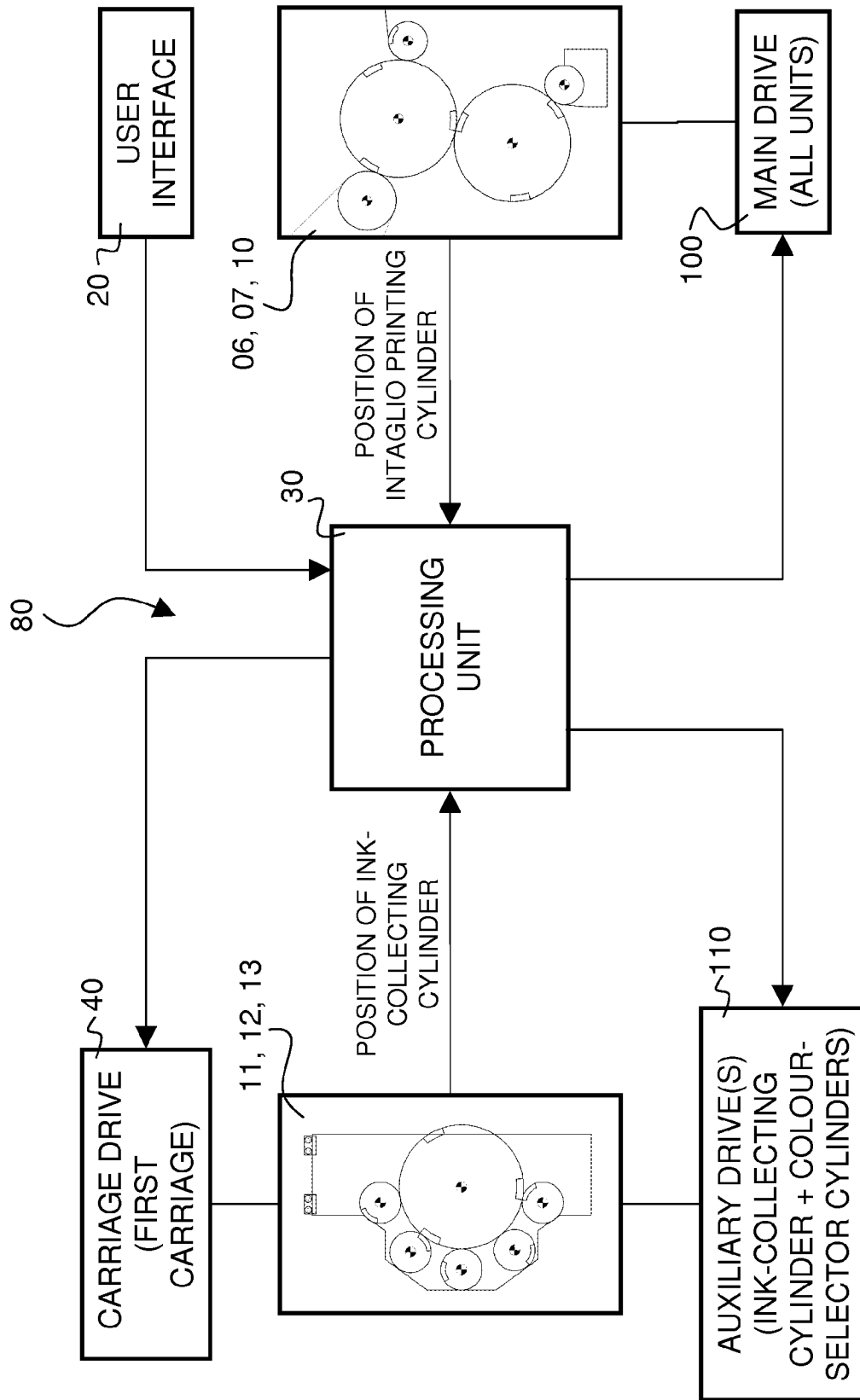

Fig. 6

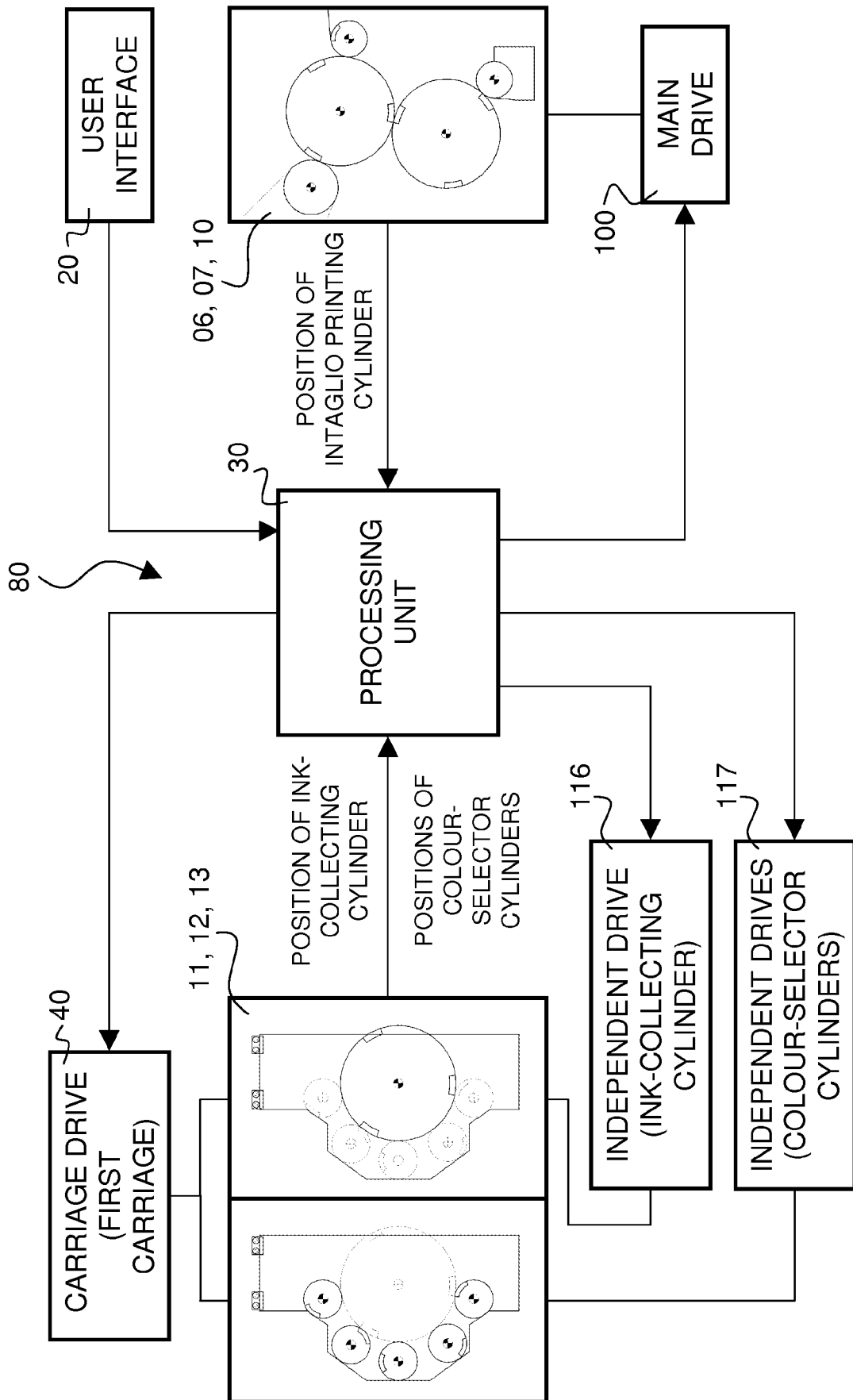

Fig. 7

# INTERNATIONAL SEARCH REPORT

International application No PCT/IB2010/055942
---

<b>A. CLASSIFICATION OF SUBJECT MATTER</b> INV. B41F13/00      B41F9/02      B41F31/00 ADD.				
According to International Patent Classification (IPC) or to both national classification and IPC				
<b>B. FIELDS SEARCHED</b>				
Minimum documentation searched (classification system followed by classification symbols) B41F				
Documentation searched other than minimum documentation to the extent that such documents are included in the fields searched				
Electronic data base consulted during the international search (name of data base and, where practical, search terms used) EPO-Internal, WPI Data				
<b>C. DOCUMENTS CONSIDERED TO BE RELEVANT</b>				
Category*	Citation of document, with indication, where appropriate, of the relevant passages	Relevant to claim No.		
X	WO 03/047862 A1 (KOENIG & BAUER AG [DE]; DUENNINGER BRIGITTE HF [DE]; KAHL GEORG [DE]) 12 June 2003 (2003-06-12) cited in the application the whole document -----	1-27		
A	EP 0 563 007 A1 (DE LA RUE GIORI SA [CH]) 29 September 1993 (1993-09-29) the whole document -----	1-27		
A	EP 1 872 944 A2 (KOENIG & BAUER AG [DE]) 2 January 2008 (2008-01-02) the whole document -----	1-8		
A	EP 0 834 398 A1 (ROLAND MAN DRUCKMASCH [DE]) 8 April 1998 (1998-04-08) the whole document -----	1-8		
----- -/--				
<input checked="" type="checkbox"/> Further documents are listed in the continuation of Box C. <input checked="" type="checkbox"/> See patent family annex.				
* Special categories of cited documents : <table style="width: 100%; border: none;"> <tr> <td style="width: 50%; border: none; vertical-align: top;">                     "A" document defining the general state of the art which is not considered to be of particular relevance                      "E" earlier document but published on or after the international filing date                      "L" document which may throw doubts on priority claim(s) or which is cited to establish the publication date of another citation or other special reason (as specified)                      "O" document referring to an oral disclosure, use, exhibition or other means                      "P" document published prior to the international filing date but later than the priority date claimed                 </td> <td style="width: 50%; border: none; vertical-align: top;">                     "T" later document published after the international filing date or priority date and not in conflict with the application but cited to understand the principle or theory underlying the invention                      "X" document of particular relevance; the claimed invention cannot be considered novel or cannot be considered to involve an inventive step when the document is taken alone                      "Y" document of particular relevance; the claimed invention cannot be considered to involve an inventive step when the document is combined with one or more other such documents, such combination being obvious to a person skilled in the art.                      "&amp;" document member of the same patent family                 </td> </tr> </table>			"A" document defining the general state of the art which is not considered to be of particular relevance "E" earlier document but published on or after the international filing date "L" document which may throw doubts on priority claim(s) or which is cited to establish the publication date of another citation or other special reason (as specified) "O" document referring to an oral disclosure, use, exhibition or other means "P" document published prior to the international filing date but later than the priority date claimed	"T" later document published after the international filing date or priority date and not in conflict with the application but cited to understand the principle or theory underlying the invention "X" document of particular relevance; the claimed invention cannot be considered novel or cannot be considered to involve an inventive step when the document is taken alone "Y" document of particular relevance; the claimed invention cannot be considered to involve an inventive step when the document is combined with one or more other such documents, such combination being obvious to a person skilled in the art. "&" document member of the same patent family
"A" document defining the general state of the art which is not considered to be of particular relevance "E" earlier document but published on or after the international filing date "L" document which may throw doubts on priority claim(s) or which is cited to establish the publication date of another citation or other special reason (as specified) "O" document referring to an oral disclosure, use, exhibition or other means "P" document published prior to the international filing date but later than the priority date claimed	"T" later document published after the international filing date or priority date and not in conflict with the application but cited to understand the principle or theory underlying the invention "X" document of particular relevance; the claimed invention cannot be considered novel or cannot be considered to involve an inventive step when the document is taken alone "Y" document of particular relevance; the claimed invention cannot be considered to involve an inventive step when the document is combined with one or more other such documents, such combination being obvious to a person skilled in the art. "&" document member of the same patent family			
Date of the actual completion of the international search	Date of mailing of the international search report			
16 March 2011	23/03/2011			
Name and mailing address of the ISA/ European Patent Office, P.B. 5818 Patentlaan 2 NL - 2280 HV Rijswijk Tel. (+31-70) 340-2040, Fax: (+31-70) 340-3016	Authorized officer  Curt, Denis			

# INTERNATIONAL SEARCH REPORT

International application No PCT/IB2010/055942
---

C(Continuation). DOCUMENTS CONSIDERED TO BE RELEVANT

Category*	Citation of document, with indication, where appropriate, of the relevant passages	Relevant to claim No.
A	EP 1 602 482 A1 (KBA GIORI SA [CH]) 7 December 2005 (2005-12-07) the whole document -----	1,15-21
A,P	EP 2 253 468 A2 (KOMORI PRINTING MACH [JP]) 24 November 2010 (2010-11-24) the whole document -----	1,27

# INTERNATIONAL SEARCH REPORT

Information on patent family members

International application No PCT/IB2010/055942
---

Patent document cited in search report	Publication date	Patent family member(s)	Publication date
WO 03047862	A1	12-06-2003	AT 477926 T 15-09-2010
		AU 2002342542 A1	17-06-2003
		CA 2468356 A1	12-06-2003
		CN 1564747 A	12-01-2005
		DE 10158093 A1	12-06-2003
		EP 1448393 A1	25-08-2004
		EP 2236294 A2	06-10-2010
		ES 2350923 T3	28-01-2011
		JP 2005512840 T	12-05-2005
		JP 2010047028 A	04-03-2010
		KR 20050039746 A	29-04-2005
		RU 2301153 C2	20-06-2007
		US 2006144265 A1	06-07-2006
		US 2004237816 A1	02-12-2004
-----			
EP 0563007	A1	29-09-1993	AT 140186 T 15-07-1996
		AU 3388193 A	30-09-1993
		CA 2091203 A1	27-09-1993
		CN 1078941 A	01-12-1993
		DE 59303169 D1	14-08-1996
		JP 3294371 B2	24-06-2002
		JP 6039990 A	15-02-1994
		RU 2107625 C1	27-03-1998
		US 5282417 A	01-02-1994
-----			
EP 1872944	A2	02-01-2008	DE 102006030286 A1 03-01-2008
-----			
EP 0834398	A1	08-04-1998	DE 19640649 A1 16-04-1998
		JP 3048980 B2	05-06-2000
		JP 10114047 A	06-05-1998
		US 5983793 A	16-11-1999
-----			
EP 1602482	A1	07-12-2005	CN 1960871 A 09-05-2007
		EP 1765594 A1	28-03-2007
		WO 2005118294 A1	15-12-2005
		JP 2008501547 T	24-01-2008
		US 2007181016 A1	09-08-2007
-----			
EP 2253468	A2	24-11-2010	CN 101890832 A 24-11-2010
		JP 2010269447 A	02-12-2010
		US 2010294149 A1	25-11-2010
-----			