

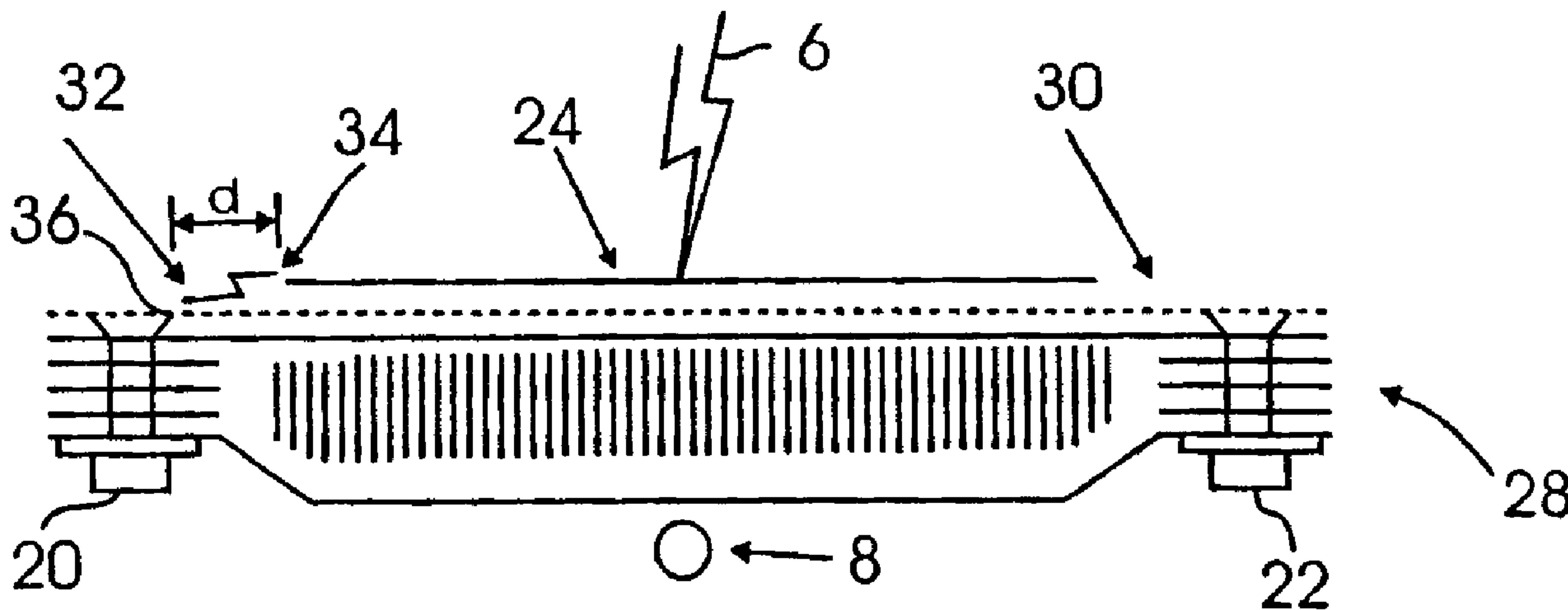

(22) Date de dépôt/Filing Date: 2007/02/21  
 (41) Mise à la disp. pub./Open to Public Insp.: 2007/08/24  
 (45) Date de délivrance/Issue Date: 2013/04/23  
 (30) Priorité/Priority: 2006/02/24 (US11/361,924)

(51) Cl.Int./Int.Cl. *H05F 3/00* (2006.01),  
*H05F 3/02* (2006.01), *H05F 3/04* (2006.01)  
 (72) Inventeur/Inventor:  
HEETER, RUSSELL JOE, US  
 (73) Propriétaire/Owner:  
THE BOEING COMPANY, US  
 (74) Agent: SIM & MCBURNEY

(54) Titre : PROTECTION DES SURFACES D'ECLAIRAGE A INTERSTICES DE STRUCTURES COMPOSITES  
 (54) Title: GAP LIGHTNING SURFACE PROTECTION OF COMPOSITE STRUCTURES



(57) Abrégé/Abstract:

A method and system of preventing lightning from puncturing composite surfaces is provided. The method includes reconfiguring plies of a composite surface so that a composite conductive ply is located on the outer surface of the composite surface and a non-conductive composite ply is located directly underneath the conductive ply and inserting a flashover point between an outer edge of the conductive ply and a fastener attaching the composite surface to a support structure.

**ABSTRACT OF THE DISCLOSURE**

A method and system of preventing lightning from puncturing composite surfaces is provided. The method includes reconfiguring plies of a composite surface so that a composite conductive ply is located on the outer surface of the composite surface and a non-conductive composite ply is located directly underneath the conductive ply and inserting a flashover point between an outer edge of the conductive ply and a fastener attaching the composite surface to a support structure.

**GAP LIGHTNING SURFACE PROTECTION OF  
COMPOSITE STRUCTURES**

**BACKGROUND OF THE INVENTION**

5           1. Field of the Invention

**[0001]** The present invention relates to lightning protection and more particularly, preventing lightning from puncturing composite surfaces.

          2. Background

10 **[0002]** External composite surfaces are susceptible to puncture when exposed to direct lightning attachment. Composite surfaces with underlying systems, such as hydraulic lines or fuel tubing, or structure require protection against the adverse effects of lightning because a puncture in the composite surface could result in a catastrophic failure, such as a spark in a  
15 fuel tank. Typically, to provide protection against lightning, metal foils or interwoven wires are added to the composite surface. Although the addition of the metal foils or interwoven wires protects against the attachment of the lightning to the underlying systems, they are heavy, difficult to apply and require special processes to prevent surface cracking due to coefficient of  
20 thermal expansion differences.

**[0003]** Parts of aircrafts, such as the fixed wing, wing to body fairing and empennage are being increasingly constructed of composite surfaces. It has been estimated that on average, each airplane in the U.S. commercial fleet is struck by lightning more than once each year. In fact, aircraft often

trigger lightning when flying through a heavily charged region of a cloud. In these instances, the lightning flash originates at the airplane and extends away in opposite directions. To prevent catastrophic failures, a method and system are needed for preventing lightning from puncturing composite surfaces that are cost effective and add minimal parasitic weight.

### SUMMARY OF THE PRESENT INVENTION

**[0004]** According to one aspect there is provided a method of preventing lightning from puncturing a composite panel, the method comprising: configuring plies of the composite panel so that a conductive ply forms an outer surface of the composite panel and a non-conductive ply is located directly underneath the conductive ply; and securing the composite panel to a support structure using at least one fastener, wherein the fastener is laterally spaced from the conductive ply by a distance  $d$ , and the fastener is not covered by the non-conductive ply, such that the distance  $d$  creates a flashover point between an outer edge of the conductive ply and the uncovered fastener.

**[0005]** According to another aspect there is provided a protection system for preventing lightning from puncturing a composite panel, comprising: conductive ply forming an outer surface of the composite panel; a non-conductive ply located directly underneath the conductive ply; a support structure; and a fastener securing the composite panel to the support structure; wherein the fastener is laterally spaced from the conductive ply by a distance  $d$ , and the fastener is not covered by the non-conductive ply, such that the distance  $d$  creates a flashover device between an outer edge of the conductive ply and the uncovered fastener.

**[0005a]** According to yet another aspect there is provided a protection system for preventing lightning from puncturing composite surfaces, comprising: a composite surface having a conductive ply directly on top of non-conductive ply; a support structure; a flashover device between an outer edge of the  
5 conductive ply and a fastener, the fastener attaching the composite surface to the support structure; and a pointed leader initiator insert secured to the fastener, with a point of the pointed leader initiator insert directed toward the outer edge of the conductive ply.

**[0005b]** According to yet another aspect there is provided a method of  
10 preventing lightning from puncturing composite surfaces, comprising: configuring plies of a composite surface so that a first composite conductive ply is located on the outer surface of the composite surface and a second non-conductive ply isolating lightning currents to the conductive ply; and inserting a flashover point, by creating a distance between an outer edge of the composite  
15 conductive ply and a fastener, attaching the composite structure to a support structure, to minimize the likelihood of puncture as a flashover voltage between conductive ply and the fastener will be reduced.

**[0005c]** According to still yet another aspect there is provided a protection system for preventing lightning from puncturing composite structures,  
20 comprising: a composite surface having a composite conductive ply directly on top of a non-conductive composite ply isolating lightning currents to the conductive ply; a support structure; and a flashover point which is a distance between an outer edge of the conductive ply and a fastener, attaching the composite structure to the support structure to minimize the likelihood of

puncture as a flashover voltage between conductive ply and the fastener will be reduced.

**[0005d]** According to yet another aspect there is provided a method of preventing lightning from puncturing composite structures, comprising:  
5 configuring plies of a composite structure so that a first composite conductive ply is located on the outer surface of the composite structure and a second non-conductive composite ply is located directly underneath the conductive ply isolating lightning currents to the conductive ply; and inserting a flashover point, by creating a distance outwards from an outer edge of the first composite  
10 conductive ply to a fastener, attaching the composite structure to a support structure, to provide a lightning path to the surrounding structure and minimize the likelihood of puncture as the flashover voltage between conductive ply and the fastener is lower than the puncture voltage.

**[0005e]** According to still yet another aspect there is provided a protection  
15 system for preventing lightning from puncturing composite structures, comprising: composite structure having a composite conductive ply directly on top of non-conductive composite ply isolating lightning current to the conductive ply; a support structure; and a flashover point which is a distance outwards from an outer edge of the conductive ply to a fastener attaching the composite  
20 structure to the support structure to provide a lightning path to the surrounding structure and minimize the likelihood of puncture as the flashover voltage between conductive ply and the fastener is lower than the puncture voltage.

**[0006]** This brief summary has been provided so that the nature of the invention may be understood quickly. A more complete understanding of the  
25 invention can be obtained by reference to the following detailed

description of the preferred embodiments thereof in connection with the attached drawings.

### BRIEF DESCRIPTION OF THE DRAWINGS

- 5    **[0007]** The foregoing features and other features of the present invention will now be described with reference to the drawings of a preferred embodiment. In the drawings, the same components have the same reference numerals. The illustrated embodiment is intended to illustrate, but not to limit the invention. The drawings include the following Figures:
- 10   **[0008]** Figures 1a illustrates a typical prior art composite panel exposed to lightning;
- [0009]** Figure 1b illustrates a typical prior art fixed leading edge composite surface exposed to lightning;
- [0010]** Figure 2a illustrates a side view of a composite panel, according to
- 15   one aspect of the present invention;
- [0011]** Figure 2b illustrates a top view of the composite panel in Figure 2a having a conductive strip;
- [0012]** Figure 2c illustrates a top view of the composite panel in Figure 2a having a leader initiator insert; and
- 20   **[0013]** Figure 3 illustrates a fixed leading edge composite panel, according to one aspect of the present invention.

## DETAILED DESCRIPTION OF THE PREFERRED EMBODIMENTS

**[0014]** The following detailed description is of the best currently contemplated modes of carrying out the invention. The description is not to be taken in a limiting sense, but is made merely for the purpose of illustrating the general principles of the invention, since the scope of the invention is best defined by the appended claims.

**[0015]** According to the present invention, an improved, cost effective and light weight protection method and system to prevent lightning from puncturing composite surfaces (or "panels" or "structures") is provided. Although the method of the present invention is implemented using an aircraft, those skilled in the art will recognize that the principles and teachings described herein may be applied to a variety of structures with composite surfaces, such as automobiles and antenna radomes.

**[0016]** Figures 1a and 1b illustrate a typical prior art composite panel 2 and fixed leading edge composite panel 4 exposed to lightning 6. Direct contact of lightning 6 can occur on panels with conductive or non-conductive plies that cover underlying systems (or "structures") 8 located close to inner surfaces 10, 12 of panels 2, 4. Non-conductive plies 14 are electrically transparent to lightning 6 and are subject to puncture, while conductive plies in composite panels may not be thick enough to prevent puncture.

**[0017]** Traditional methods and systems of preventing punctures to protection systems have included adding metallized surface protection on outer surfaces 16, 18 of composite panels 2, 4. The addition of the metallized surface protection allows current generated from lightning 6 to

flow through outer surfaces 16, 18 of panels 2, 4 to supporting structures which can include numerous fasteners, such as first and second fasteners 20, 22, attached to the primary structure. The performance of the lightning protection system depends on the ply composition and surface protection  
5 configuration of composite panels.

**[0018]** Conventional composite panels 2, 4 are comprised of several plies 26 of fiberglass stacked up. By changing composite panels 2, 4 to include a hybrid stack up, for example, fiberglass is mixed with carbon fiber reinforced plastic (CFRP), the sequence of the ply layers can be changed which results  
10 in the reduction of the number of plies and subsequently a reduction in weight. Instead of using three plies of fiberglass, a single fiberglass hybrid and a single CFRP ply can be utilized. A hybrid ply can be comprised of fiberglass, KEVLAR® or the combination of fiberglass or KEVLAR® and CFRP.

**[0019]** Turning to Figures 2a-c, a composite panel 28 according to the present invention is provided. The configuration of the stack up of the plies in composite panel 28 is re-arranged so that a conductive ply 24 is located on the outer surface of composite panel 28 and is directly on top of a non-conductive ply 30. As a result, composite panels can be provided the same  
20 level of protection against lightning attachment 27 at less cost, less weight and greater simplicity. The first two plies 24, 30 play a crucial role in preventing puncture and by configuring non-conductive ply 30 under conductive ply 24, lightning currents to conductive ply 28 of composite panel

24 are isolated. The remaining underlying plies can be configured in any order.

[0020] In addition to re-arranging the ply lay up, a flashover point (or "device") 32 is added between edge 34 of outer conductive ply 24, generally comprised of CFRP, and first fastener 20 to prevent galvanic corrosion as the carbon fibers in the CFRP do not come into contact with first fastener 20. When lightning attaches 6 anywhere on outer conductive ply 24, a voltage occurs between edge 34 of outer conductive ply 24 and first fastener 20. If this voltage is high enough to create an ionized path between edge 34 of outer conductive ply 24 and fastener edge 36, puncture will not occur. Flashover (or "device") 32 creates a length or distance "d", which is the distance between edge 34 of outer conductive ply 24 and first fastener 20, to minimize the likelihood of puncture to underlying systems 8 as the flashover voltage between conductive ply 24 and first fastener 20 will be reduced. System 8 can be any underlying system, for example, a fuel tube, hydraulic systems or any other system. Instead of lightning 6 attaching to underlying systems 8, the current produced by lightning 6 flashes over and flows through first fastener 20. In other words, lightning 6 attaches to conductive ply 24 causing current to flow through conductive surface 24 and flash over distance "d" to first fastener 20.

[0021] In a preferred embodiment, distance "d" is a quarter inch (0.25 in) so voltage occurs between conductive ply 24 and first fastener 20, while allowing the current to divert along the surface of panel 28 only and not

puncture and attach to underlying systems 8. Flashover (or "device") 32 provides a lightning current path to surrounding structure.

**[0022]** If distance "d" is required to be so large that the resulting flashover voltage is greater than the puncture voltage, additional devices, such as  
5 conductive strips and leader initiator inserts are required to prevent puncture. As shown in the top-view of Figure 2b, a conductive strip 38 is applied from conductive ply 24 to a second fastener 22 of composite panel 28. Conductive strip 38 reduces the voltage required for lightning current to flow from conductive ply 24 over to second fastener 22. Conductive strip 38  
10 is made from copper or other type of (galvanically compatible metal) conductive material that electrically grounds conductive ply 24 to second fastener 22. Conductive strip 38 can be part of the lay up built into composite panel 28.

**[0023]** Alternatively, a leader initiator insert 40 can be inserted on a third  
15 fastener 42, as shown in the top-view of Figure 2c. Leader initiator insert 40 is comprised of metal and has a sharp point directed toward the edge of conductive ply 24 to reduce flashover voltage and the likelihood of puncture. Leader initiator insert 40 is only required if distance "d" is large enough to cause the flashover voltage to be greater than the puncture voltage. For  
20 example, if the design of a composite panel requires distance "d" to be an inch between conductive ply 24 and first fastener 20 to prevent corrosion, leader initiator insert 40 can also be inserted so lightning protection is provided and galvanic corrosion is prevented.

**[0024]** Figure 3 illustrates the method and system described above applied to a fixed leading edge composite panel 44. Lightning 6 attaches to a conductive ply of fixed leading edge composite panel 44 producing a current which causes an arc of voltage 46 on outer surface 48 of panel 44. As a  
5 result, lightning 6 does not attach to underlying systems 8 preventing a failure of underlying systems 8.

**[0025]** Although the present invention has been described with reference to specific embodiments, these embodiments are illustrative only and not limiting. Many other applications and embodiments of the present invention  
10 will be apparent in light of this disclosure and the following claims.

**What is claimed is:**

1. A method of preventing lightning from puncturing a composite panel, the method comprising:

configuring plies of the composite panel so that a conductive ply forms an outer surface of the composite panel and a non-conductive ply is located directly underneath the conductive ply; and

securing the composite panel to a support structure using at least one fastener;

wherein the fastener is laterally spaced from the conductive ply by a distance  $d$ , and the fastener is not covered by the non-conductive ply, such that the distance  $d$  creates a flashover point between an outer edge of the conductive ply and the uncovered fastener.

2. The method of claim 1, wherein the length of the flashover point is about 0.25 inches.

3. The method of claim 1 or 2, further comprising placing a conductive strip between the conductive ply and the fastener.

4. The method of claim 3, wherein the conductive strip reduces the voltage required for lightning current to flow from the conductive ply over to the fastener.

5. The method of any one of claims 1 to 4, wherein the conductive ply comprises carbon fiber reinforced plastic (CFRP).
6. The method of any one of claims 1 to 4, wherein the non-conductive ply is selected from the group consisting of para-aramids and fiberglass.
7. A method of preventing lightning from puncturing a composite surface, the method comprising:
  - configuring plies of a composite surface so that a conductive ply is located on the outer surface of the composite surface and a non-conductive ply is located directly underneath the conductive ply;
  - inserting a flashover point between an outer edge of the conductive ply and a fastener, the fastener attaching the composite surface to a support structure; and
  - placing a pointed leader initiator insert over the fastener with a point of the pointed leader initiator insert directed toward the outer edge of the conductive ply.
8. The method of claim 7, wherein the length of the flashover point is 0.25 inches.
9. The method of claim 7 or 8, further comprising placing a conductive strip between the conductive ply and the fastener.

10. The method of any one of claims 7 to 9, wherein the conductive ply comprises carbon fiber reinforced plastic (CFRP).

11. The method of any one of claims 7 to 9, wherein the non-conductive ply is selected from the group consisting of para-aramids and fiberglass.

12. A protection system for preventing lightning from puncturing a composite panel, comprising:

conductive ply forming an outer surface of the composite panel;

a non-conductive ply located directly underneath the conductive ply;

a support structure; and

a fastener securing the composite panel to the support structure;

wherein the fastener is laterally spaced from the conductive ply by a distance  $d$ , and the fastener is not covered by the non-conductive ply, such that the distance  $d$  creates a flashover device between an outer edge of the conductive ply and the uncovered fastener.

13. The system of claim 12, wherein the length of the flashover device is about 0.25 inches.

14. The system of claim 12 or 13, further comprising a conductive strip between the conductive ply and the fastener.

15. The system of claim 14, wherein the conductive strip reduces the voltage required for lightning current to flow from the conductive ply over to the fastener.
16. The system of any one of claims 12 to 15, wherein the conductive ply comprises carbon fiber reinforced plastic (CFRP).
17. The system of any one of claims 12 to 15, wherein the non-conductive ply is selected from the group consisting of para-aramids and fiberglass.
18. A protection system for preventing lightning from puncturing composite surfaces, comprising:
- a composite surface having a conductive ply directly on top of non-conductive ply;
  - a support structure;
  - a flashover device between an outer edge of the conductive ply and a fastener, the fastener attaching the composite surface to the support structure; and
  - a pointed leader initiator insert secured to the fastener, with a point of the pointed leader initiator insert directed toward the outer edge of the conductive ply.
19. The system of claim 18, wherein the length of the flashover device is 0.25 inches.

- 20. The system of claim 18 or 19, further comprising a conductive strip extending between the conductive ply and the fastener.**
- 21. The system of any one of claims 18 to 20, wherein the conductive ply comprises carbon fiber reinforced plastic (CFRP).**
- 22. The system of any one of claims 18 to 20, wherein the non-conductive ply is selected from the group consisting of para-aramids and fiberglass.**
- 23. A method of preventing lightning from puncturing composite surfaces, comprising:**
- configuring plies of a composite surface so that a first composite conductive ply is located on the outer surface of the composite surface and a second non-conductive ply isolating lightning currents to the conductive ply;**
- and**
- inserting a flashover point, by creating a distance between an outer edge of the composite conductive ply and a fastener, attaching the composite structure to a support structure, to minimize the likelihood of puncture as a flashover voltage between conductive ply and the fastener will be reduced.**
- 24. The method of claim 23, further comprising placing a conductive strip between the composite conductive ply and another fastener.**

**25. The method of claim 23 or 24, further comprising placing a pointed leader initiator insert inserted over the fastener with the point directed toward the edge of the composite conductive ply.**

**26. The method of claim 24, wherein the conductive strip reduces the voltage required for lightning current to flow from the composite conductive ply over to the fastener.**

**27. A protection system for preventing lightning from puncturing composite structures, comprising:**

**a composite surface having a composite conductive ply directly on top of a non-conductive composite ply isolating lightning currents to the conductive ply;**

**a support structure; and**

**a flashover point which is a distance between an outer edge of the conductive ply and a fastener, attaching the composite structure to the support structure to minimize the likelihood of puncture as a flashover voltage between conductive ply and the fastener will be reduced.**

**28. The system of claim 27, wherein the length of the flashover device is 0.25 inches.**

**29. The system of claim 27 or 28, wherein the composite conductive ply is comprised of carbon fiber reinforced plastic (CFRP).**

30. The system of any one of claims 27 to 29, wherein the non-conductive ply is selected from the group consisting of para-aramid and fiberglass.

31. A method of preventing lightning from puncturing composite structures, comprising:

configuring plies of a composite structure so that a first composite conductive ply is located on the outer surface of the composite structure and a second non-conductive composite ply is located directly underneath the conductive ply isolating lightning currents to the conductive ply; and

inserting a flashover point, by creating a distance outwards from an outer edge of the first composite conductive ply to a fastener, attaching the composite structure to a support structure, to provide a lightning path to the surrounding structure and minimize the likelihood of puncture as the flashover voltage between conductive ply and the fastener is lower than the puncture voltage.

32. The method of claim 31, further comprising placing a conductive strip between the composite conductive ply and another fastener.

33. The method of claim 31 or 32, further comprising placing a pointed leader initiator insert inserted over the fastener with the point directed toward the edge of the composite conductive ply.

**34. The method of claim 32, wherein the conductive strip reduces the voltage required for lightning current to flow from the composite conductive ply over to the fastener.**

**35. A protection system for preventing lightning from puncturing composite structures, comprising:**

**composite structure having a composite conductive ply directly on top of non-conductive composite ply isolating lightning current to the conductive ply;**

**a support structure; and**

**a flashover point which is a distance outwards from an outer edge of the conductive ply to a fastener attaching the composite structure to the support structure to provide a lightning path to the surrounding structure and minimize the likelihood of puncture as the flashover voltage between conductive ply and the fastener is lower than the puncture voltage.**

**36. The system of claim 35, wherein the length of the flashover device is 0.25 inches.**

**37. The system of claim 35 or 36, wherein the composite conductive ply is comprised of carbon fiber reinforced plastic (CFRP).**

**38. The system of any one of claims 35 to 37, wherein the non-conductive ply is selected from the group consisting of para-aramid and fiberglass.**

1/3

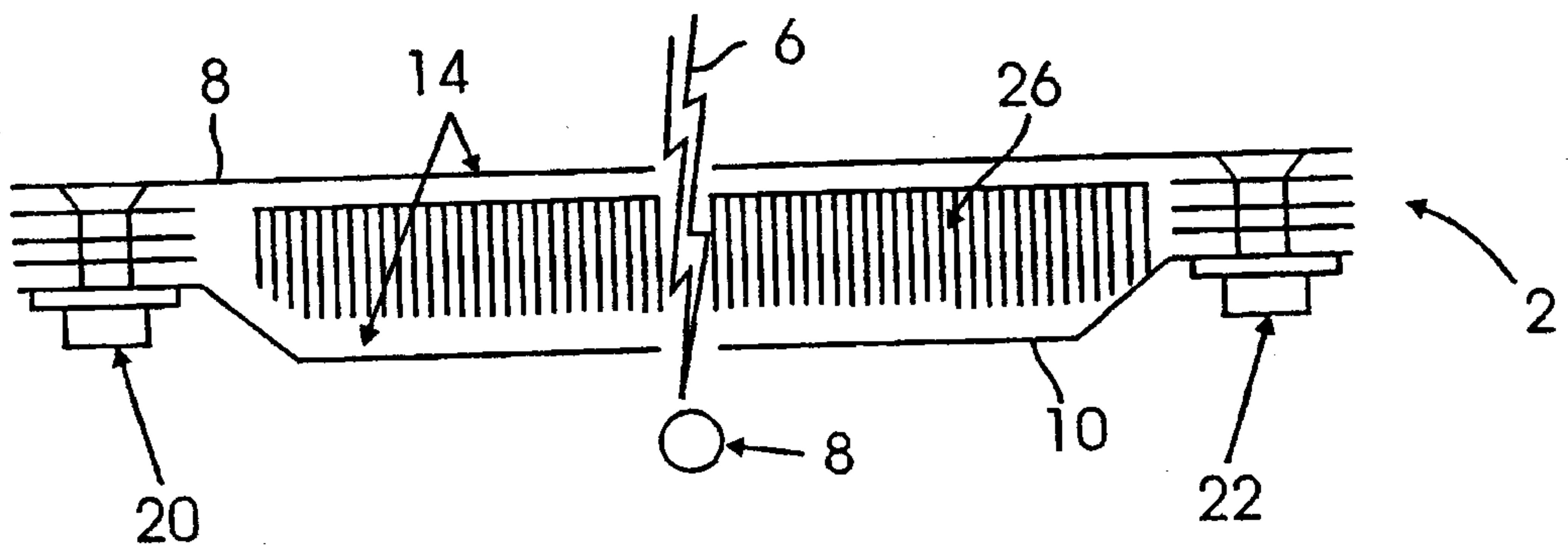

Fig. 1A (Prior Art)

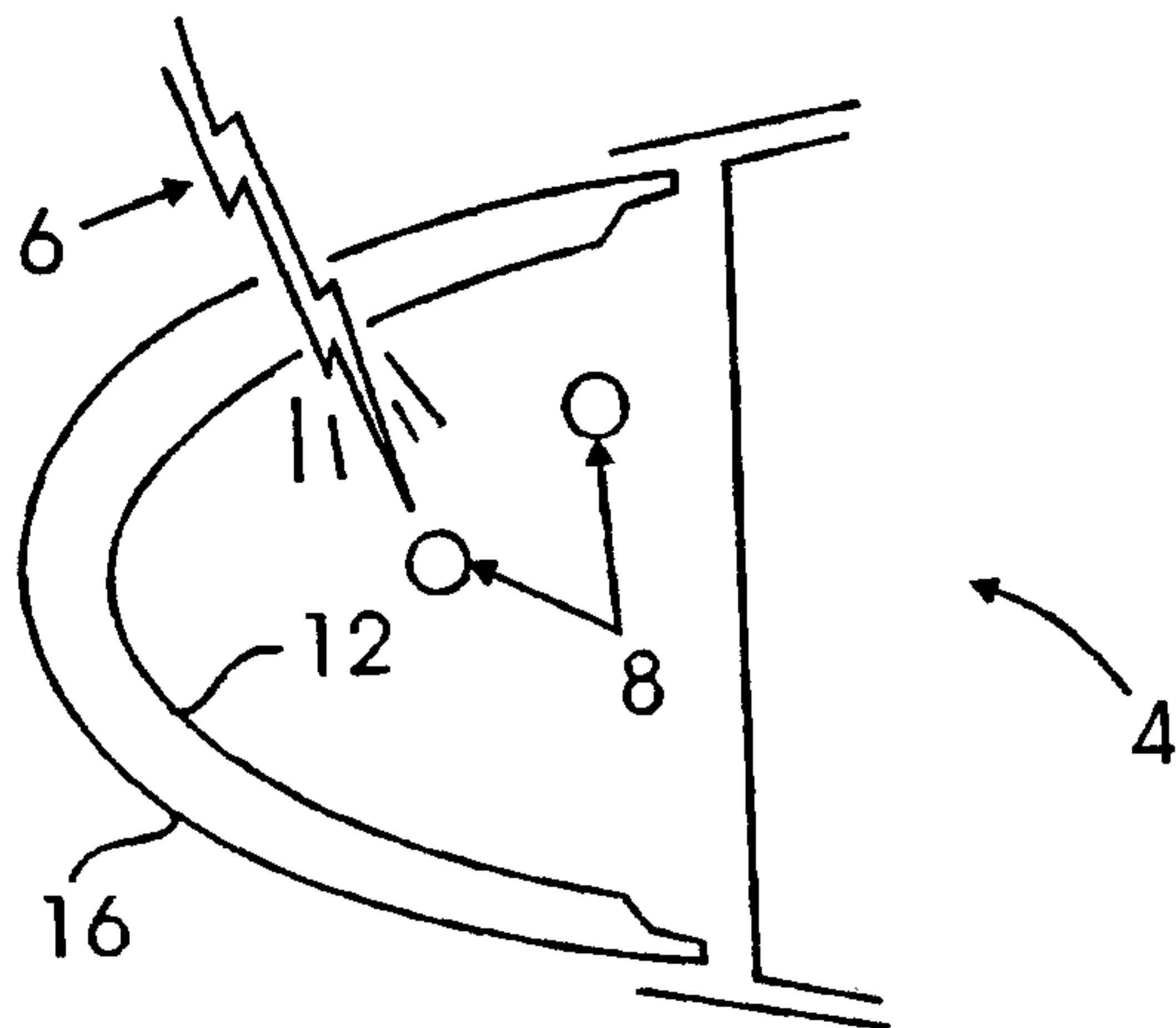

Fig. 1B (Prior Art)

2/3

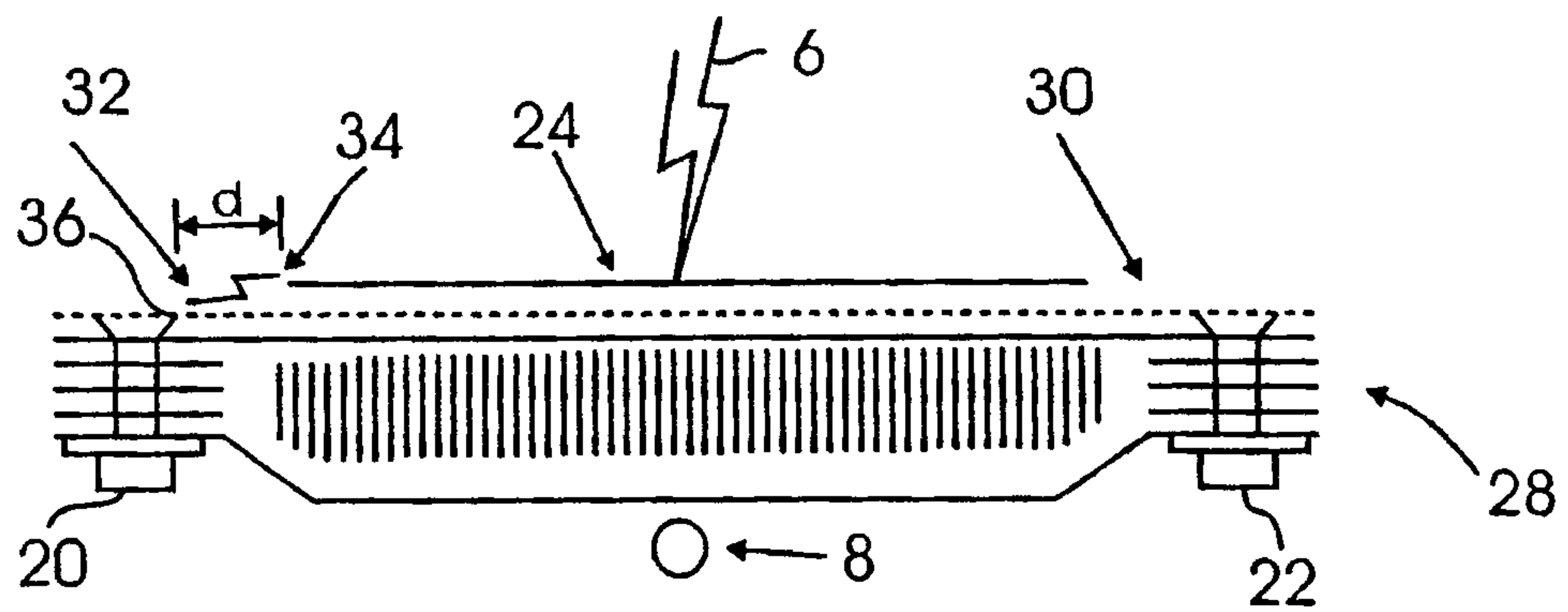

Fig. 2A

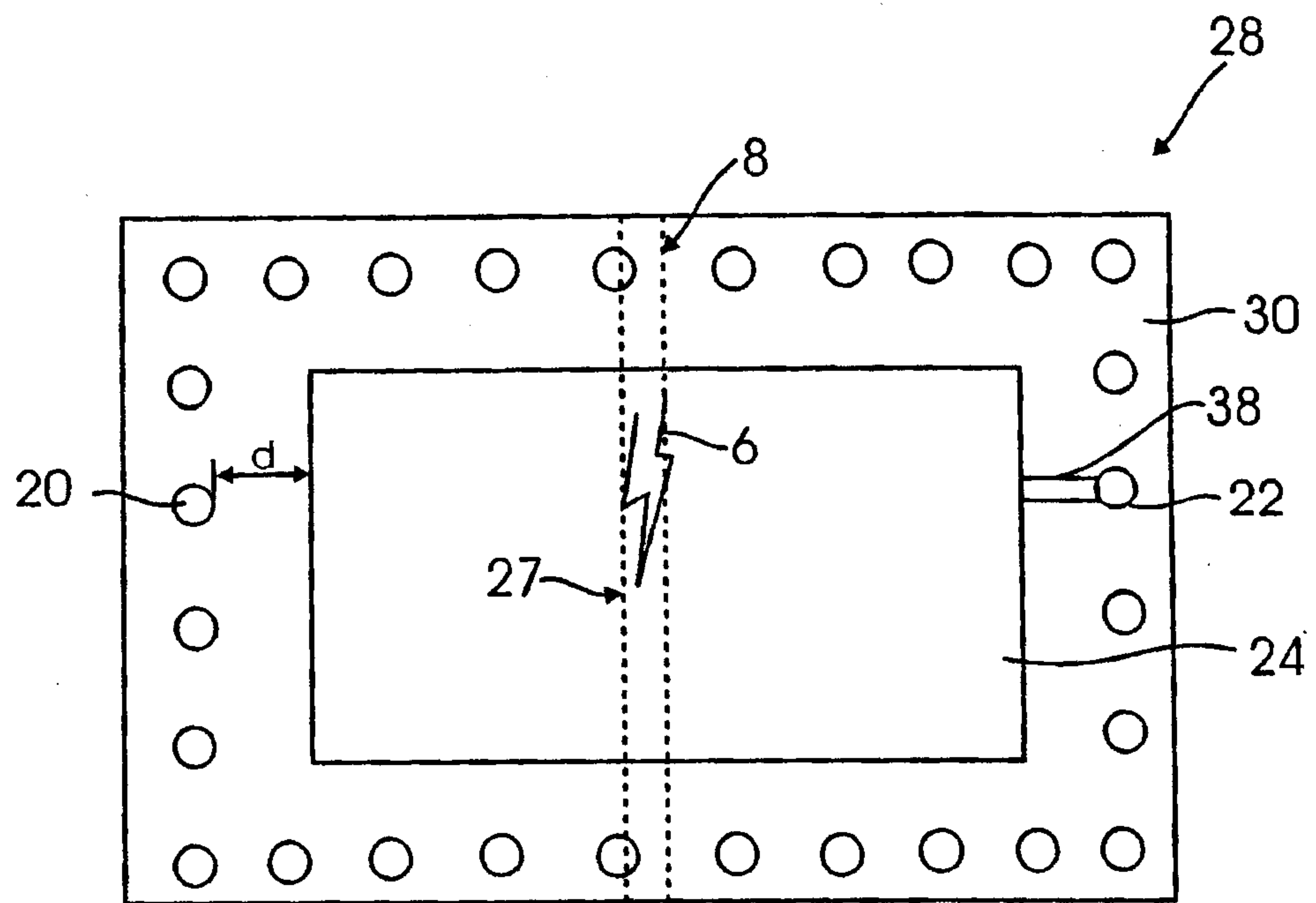

Fig. 2B

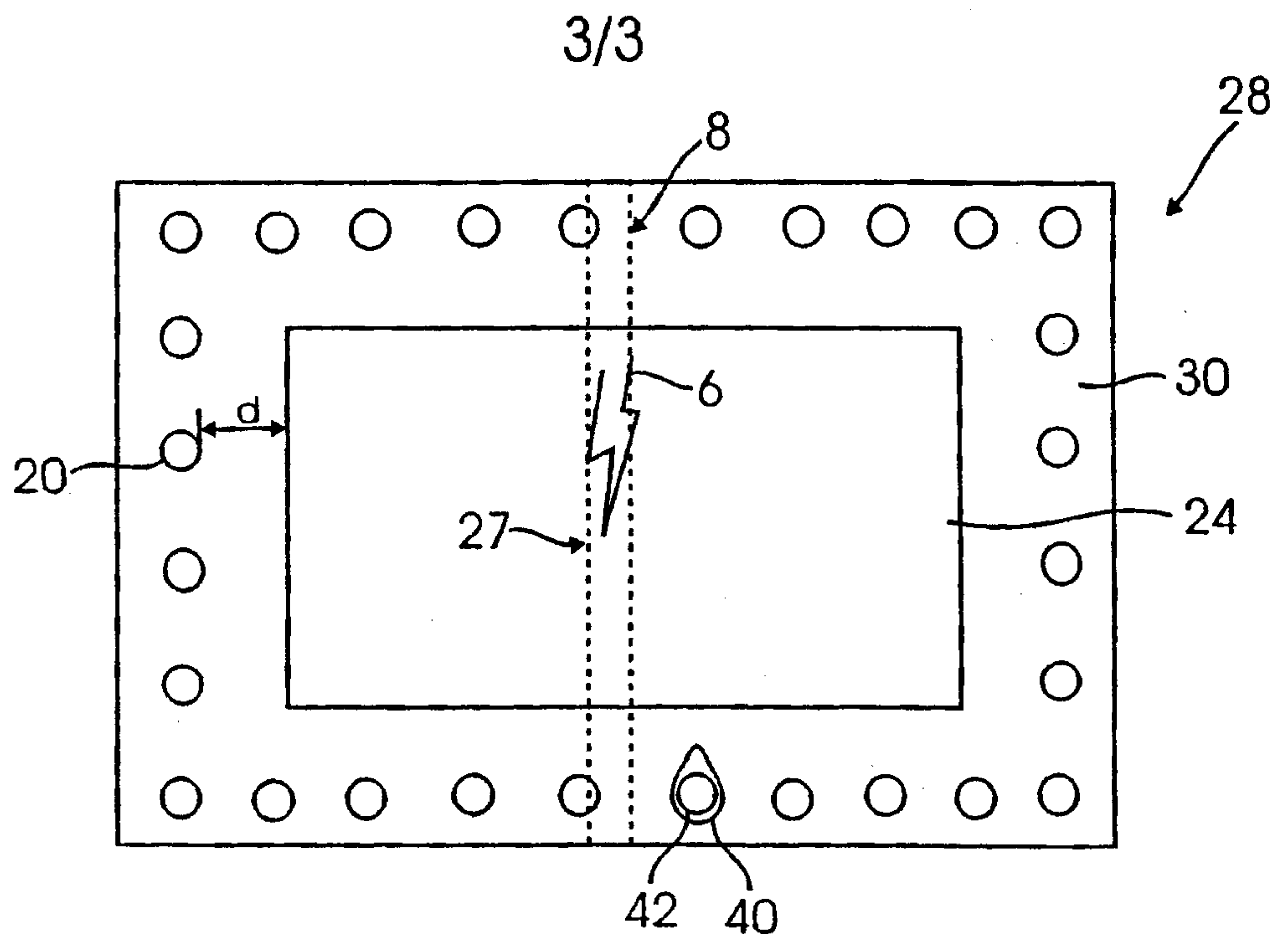

Fig. 2C

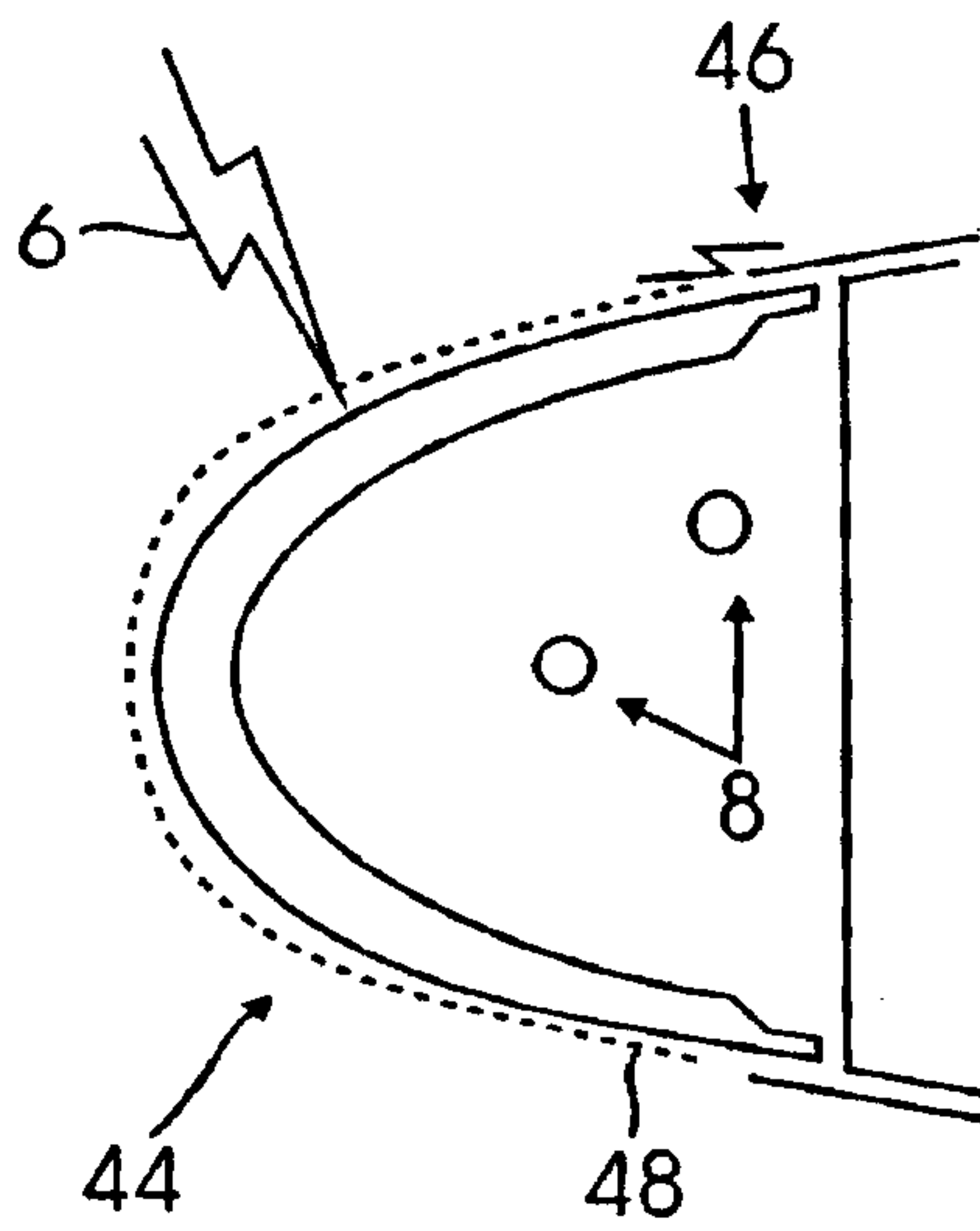

Fig. 3

