



(51) International Patent Classification:

H01M 2/10 (2006.01) *H01M 10/48* (2006.01)
H01M 10/42 (2006.01) *H01M 2/20* (2006.01)

(21) International Application Number:

PCT/US2017/026529

(22) International Filing Date:

7 April 2017 (07.04.2017)

(25) Filing Language:

English

(26) Publication Language:

English

(30) Priority Data:

15/094,662 8 April 2016 (08.04.2016) US

(71) Applicant: **LOCKHEED MARTIN CORPORATION** [US/US]; 6801 Rockledge Drive, Bethesda, Maryland 20817 (US).

(72) Inventors: **ZIMBRU, JR., George, C.**; 702 Kensington Drive, Duncanville, Texas 75137 (US). **IEBIG, Bradley**; 4213 Woodcrest Lane, Mansfield, Texas 76063 (US). **HOMIAK, Daniel**; 1328 E. Highland Road, Waxahachie, Texas 75167 (US). **OLIVER, Glen**; 5505 Forest Bend Drive, Arlington, Texas 76017 (US).

(74) Agent: **JENSEN, Eric, P.**; Withrow & Terranova, P.L.L.C., 106 Pinedale Springs Way, Cary, North Carolina 27511 (US).

(81) Designated States (unless otherwise indicated, for every kind of national protection available):

AE, AG, AL, AM, AO, AT, AU, AZ, BA, BB, BG, BH, BN, BR, BW, BY, BZ, CA, CH, CL, CN, CO, CR, CU, CZ, DE, DJ, DK, DM, DO, DZ, EC, EE, EG, ES, FI, GB, GD, GE, GH, GM, GT, HN, HR, HU, ID, IL, IN, IR, IS, JP, KE, KG, KH, KN, KP, KR, KW, KZ, LA, LC, LK, LR, LS, LU, LY, MA, MD, ME, MG, MK, MN, MW, MX, MY, MZ, NA, NG, NI, NO, NZ, OM, PA, PE, PG, PH, PL, PT, QA, RO, RS, RU, RW, SA, SC, SD, SE, SG, SK, SL, SM, ST, SV, SY, TH, TJ, TM, TN, TR, TT, TZ, UA, UG, US, UZ, VC, VN, ZA, ZM, ZW.

(84) Designated States (unless otherwise indicated, for every kind of regional protection available):

ARIPO (BW, GH, GM, KE, LR, LS, MW, MZ, NA, RW, SD, SL, ST, SZ, TZ, UG, ZM, ZW), Eurasian (AM, AZ, BY, KG, KZ, RU, TJ, TM), European (AL, AT, BE, BG, CH, CY, CZ, DE, DK, EE, ES, FI, FR, GB, GR, HR, HU, IE, IS, IT, LT, LU, LV, MC, MK, MT, NL, NO, PL, PT, RO, RS, SE, SI, SK, SM, TR), OAPI (BF, BJ, CF, CG, CI, CM, GA, GN, GQ, GW, KM, ML, MR, NE, SN, TD, TG).

Published:

— with international search report (Art. 21(3))

(54) Title: MODULAR ENERGY STORAGE COMPONENT ENCLOSURE

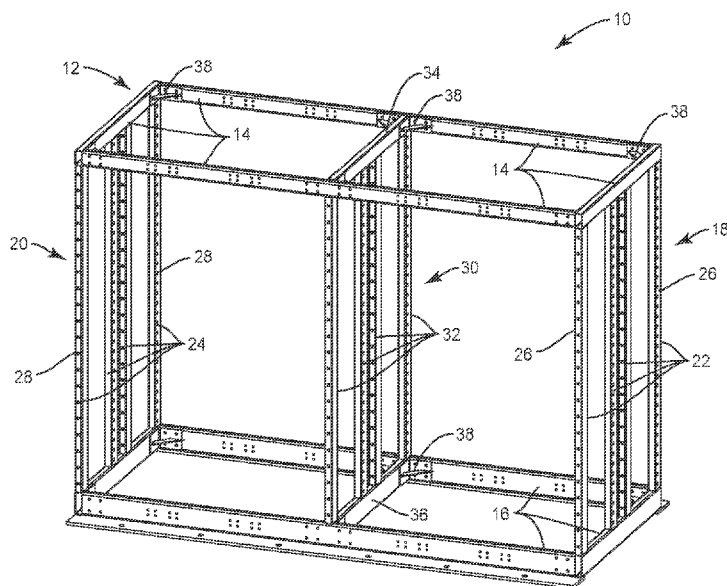

FIG. 1

(57) Abstract: An energy storage component (ESC) enclosure is provided. The ESC enclosure includes a plurality of ESC modules. Each ESC module includes at least one side portion having a plurality of side fastening mechanisms configured to be coupled to an adjacent ESC module, wherein the plurality of ESC modules is coupled together via the plurality of side fastening mechanisms to form an ESC enclosure. The ESC enclosure further includes a plurality of shelving kits, each shelving kit mounted to one of the ESC modules. The ESC enclosure further includes a roof that is coupled to the plurality of ESC modules, and a plurality of panels coupled to the plurality of ESC modules about a perimeter of the ESC enclosure to form a shared air space within the ESC enclosure.



MODULAR ENERGY STORAGE COMPONENT ENCLOSURE

TECHNICAL FIELD

[0001] The embodiments relate to energy storage and, in particular, to a
5 modular energy storage component enclosure.

BACKGROUND

[0002] Power generation facilities often need to temporarily store relatively
large amounts of surplus energy. Conventional commercial energy storage
10 systems (ESSs) typically follow a building model and are large enough for a
human to enter an interior volume of the ESS, where the particular energy
storage technology can be maintained and operated while protected from the
environment. Unfortunately, a building model such as this implicates building
codes and regulations, and adds to the cost and complexity of building an ESS.
15 Such ESSs are also generally not scalable, so that as energy storage needs
increase, it is necessary to construct more buildings. Each building has its own
thermal management infrastructure, electrical distribution infrastructure, control
and communications infrastructure, and the like. Constructing such buildings can
take a relatively long time and can have a relatively substantial footprint,
20 increasing space requirements.

SUMMARY

[0003] The embodiments relate to a modular energy storage component
(ESC) enclosure. The ESC enclosure provides access to electric storage
25 components from outside the ESC enclosure and is not human-occupiable,
facilitating smaller and quickly deployable ESC enclosures. The embodiments
are scalable, allowing existing ESC enclosures to be relatively easily enlarged in
size or reduced in size as desired. An ESC enclosure is made up of multiple
connected ESC modules that share infrastructure, such as thermal management
30 and control and communications infrastructures. Each ESC module includes

connectable features that facilitate connection of the ESC modules to form the ESC enclosure that has a shared air space.

[0004] In one embodiment, a method for assembling an energy storage component (ESC) enclosure is provided. The method includes determining a
5 quantity of energy storage components to be enclosed. The method further includes selecting a particular shelving kit style of a plurality of different shelving kit styles based on a type of energy storage component to be enclosed. The method further includes determining a number N greater than 1 of a plurality of
10 ESC modules required to enclose the quantity of energy storage components based on the shelving kit style. The method further includes placing the N number of ESC modules adjacent to one another, each ESC module including at least one side portion that is configured to be coupled to a side portion of an adjacent ESC module. The method further includes inserting into each ESC
15 module of the N number of ESC modules a shelving kit of the particular shelving kit style. The method further includes coupling the N number of ESC modules together via respective side portions to form an ESC enclosure. The method further includes mounting a roof on the ESC enclosure, and coupling a plurality of panels completely about a perimeter of the ESC enclosure to form an enclosed shared air space within the ESC enclosure.

[0005] In another embodiment, an ESC enclosure is provided. The ESC
20 enclosure includes a plurality of ESC modules. Each ESC module includes at least one side portion having a plurality of side fastening mechanisms configured to be coupled to an adjacent ESC module, wherein the plurality of ESC modules is coupled together via the plurality of side fastening mechanisms to form an ESC
25 enclosure. The ESC enclosure further includes a plurality of shelving kits, each shelving kit mounted to one of the ESC modules. The ESC enclosure further includes a roof that is coupled to the plurality of ESC modules and a plurality of panels coupled to ESC modules about a perimeter of the ESC modules to form a shared air space within the ESC enclosure.

[0006] Those skilled in the art will appreciate the scope of the disclosure and realize additional aspects thereof after reading the following detailed description of the embodiments in association with the accompanying drawing figures.

5 BRIEF DESCRIPTION OF THE DRAWINGS

[0007] The accompanying drawing figures incorporated in and forming a part of this specification illustrate several aspects of the disclosure, and together with the description serve to explain the principles of the disclosure.

[0008] Figure 1 illustrates an electronic storage component (ESC) module
10 according to one embodiment;

[0009] Figure 2 illustrates a first style of a shelving kit according to one embodiment;

[0010] Figure 3 illustrates a second style of a shelving kit according to another embodiment;

15 **[0011]** Figure 4 illustrates the ESC module with an installed shelving kit according to one embodiment;

[0012] Figure 5 illustrates a roof coupled to a frame according to one embodiment;

20 **[0013]** Figure 6 illustrates an enlarged portion of the ESC module at a location where the roof is fixed to the frame according to one embodiment;

[0014] Figure 7 illustrates the ESC module with a plurality of panels coupled to the ESC module according to one embodiment;

[0015] Figure 8 illustrates a plurality of ESC modules positioned to be coupled together to form an ESC enclosure according to one embodiment;

25 **[0016]** Figure 9 illustrates a portion of the ESC enclosure at a location wherein a first ESC module is coupled to a second ESC module according to one embodiment;

[0017] Figure 10 illustrates a portion of the ESC enclosure at location wherein a gasket and an end panel are coupled to a first side portion of an ESC module
30 according to one embodiment;

[0018] Figure 11 illustrates the ESC enclosure according to one embodiment;

[0019] Figure 12 illustrates the ESC enclosure illustrated in Figure 11 without any panels so that certain internal features of the ESC enclosure can be viewed;

[0020] Figure 13 illustrates an enlarged first portion of Figure 12 according to one embodiment;

5 **[0021]** Figure 14 illustrates an enlarged second portion of Figure 12 according to one embodiment; and

[0022] Figure 15 is a flowchart of a method for assembling the ESC enclosure according to one embodiment.

10 DETAILED DESCRIPTION

[0023] The embodiments set forth below represent the information to enable those skilled in the art to practice the embodiments and illustrate the best mode of practicing the embodiments. Upon reading the following description in light of the accompanying drawing figures, those skilled in the art will understand the
15 concepts of the disclosure and will recognize applications of these concepts not particularly addressed herein. It should be understood that these concepts and applications fall within the scope of the disclosure and the accompanying claims.

[0024] Any flowcharts discussed herein are necessarily discussed in some sequence for purposes of illustration, but unless otherwise explicitly indicated,
20 the embodiments are not limited to any particular sequence of steps. The use herein of ordinals in conjunction with an element is solely for distinguishing what might otherwise be similar or identical labels, such as “first ESC module” and “second ESC module,” and does not imply a priority, a type, an importance, or other attribute, unless otherwise stated herein.

25 **[0025]** The embodiments relate to a modular energy storage component (ESC) enclosure. The ESC enclosure provides access to electric storage components from outside the ESC enclosure. The ESC enclosure lacks a center aisle sufficient to facilitate ingress by a human; it is thus not human-occupiable, facilitating smaller and quickly deployable ESC enclosures. The embodiments
30 are easily scalable, allowing existing ESC enclosures to be relatively easily enlarged in size or reduced in size as desired. An ESC enclosure is made up of

multiple connected ESC modules that share infrastructure, such as thermal management and control and communications infrastructure. Each ESC module includes connectable features that facilitate connection of the ESC modules to form the ESC enclosure that has a shared air space.

5 **[0026]** Figure 1 illustrates an electronic storage component (ESC) module 10 according to one embodiment. The ESC module 10 is configured to receive a plurality of different shelving kit styles. The term shelving kit styles includes racking kit styles. The shelving kits discussed herein are hot-swappable, reconfigurable, and mix and matchable. The ESC module 10 includes a frame
10 12 that includes a top perimeter frame 14 and a bottom perimeter frame 16. The top perimeter frame 14 and the bottom perimeter frame 16 are each rectangular. The frame 12 also includes a first side 18 and a second side 20. The first side 18 includes a plurality of first side members 22 that extend from the top perimeter frame 14 to the bottom perimeter frame 16. The second side 20 includes a
15 plurality of second side members 24 that extend from the top perimeter frame 14 to the bottom perimeter frame 16. As will be discussed below in greater detail, the first side members 22 include first side portions 26 that have a plurality of side fastening mechanisms (not illustrated in Figure 1) that are configured to be coupled to an adjacent ESC module 10. The second side members 24 include
20 second side portions 28 that have a plurality of side fastening mechanisms (not illustrated in Figure 1) that are configured to be coupled to an adjacent ESC module 10. The ESC module 10 includes a floor that is sealed, preventing water, insects, and air from entering the shared air space.

[0027] The frame 12 also includes a central upright structure 30 that includes
25 a plurality of central upright members 32, a top cross bar 34 and a bottom cross bar 36. In this example, the frame 12 also includes a plurality of corner brackets 38 (only some of which are labelled in Figure 1).

[0028] Figure 2 illustrates a first style 40 of a shelving kit 42 according to one
30 embodiment. The shelving kit 42 is configured to support a plurality of energy storage components. The energy storage components may comprise any component capable of storing energy, including, by way of non-limiting example,

electro-chemical storage devices, capacitors, electromechanical storage systems, fuel cells, flow batteries, thermal-electrical storage systems, lithium ion batteries, lead acid batteries, and the like. In this example, the shelving kit 42 is configured to support a plurality of lithium ion batteries, and the first style 40 is a lithium ion battery style.

The shelving kit 42 includes a plurality of upright members 44, each upright member 44 having a top end 46 and a bottom end 48. The top end 46 of each upright member 44 can be coupled to the top perimeter frame 14 of the ESC module 10 (Figure 1) to fix the shelving kit 42 with respect to the top perimeter frame 14. The bottom end 48 of each upright member 44 can be coupled to the bottom perimeter frame 16 of the ESC module 10 to fix the shelving kit 42 with respect to the bottom perimeter frame 16. Because the shelving kit 42 is coupled directly to the frame 12 (Figure 1), the shelving kit 42 increases the load bearing capability, rigidity, and structural integrity of the ESC module 10.

[0029] Figure 3 illustrates a second style 50 of a shelving kit 52 according to one embodiment. The shelving kit 52 is configured to support a plurality of energy storage components. In particular, the shelving kit 52 is configured to support a plurality of lead acid batteries, and the second style 50 is a lead acid battery style. The shelving kit 52 comprises a plurality of shelves 54. Each shelf 54 includes a first end member 56 configured to be coupled to the central upright structure 30 of the ESC module 10 (Figure 1). Some of the shelves 54 include second end members 56-1 that are configured to be coupled to the first side members 22 of the ESC module 10. Other of the shelves 54 include second end members 56-2 that are configured to be coupled to the second side members 24 of the ESC module 10. As discussed above with regard to Figure 2, because the shelving kit 52 is coupled directly to the frame 12 (Figure 1), the shelving kit 52 increases the load bearing capability, rigidity, and structural integrity of the ESC module 10.

[0030] Figure 4 illustrates the ESC module 10 with the shelving kit 42 installed such that the shelving kit 42 is fixed with respect to the frame 12 of the ESC module 10. The ESC module 10 includes a plurality of power busses 58 that are

configured to carry electrical energy to and from the energy storage components. In this example, the power busses 58 hang from support members 60 and are electrically insulated from the support members 60 via a plurality of insulators 62. The power busses 58 may comprise, by way of non-limiting example, cables, switch gear, conduit and fluidic media, wireless busses, and the like. The ESC module 10 also includes a plurality of sensors 61-1 – 61-3, each of which may be configured to identify a characteristic of the shared air space of multiple ESC modules 10 coupled together to form an ESC enclosure. The plurality of sensors 61-1 – 61-3, may comprise, by way of non-limiting example, one or more of a smoke sensor, a hydrogen sensor, a humidity sensor, a temperature sensor, or a gas sensor. The characteristic thus may comprise, by way of non-limiting example, whether smoke is present in the shared air space, a temperature of the shared air space, a humidity of the shared air space, a pressure of the shared air space, whether hydrogen or some other gas is present in the shared air space, and the like.

[0031] A roof 64 is configured to be mounted to the ESC module 10. The roof 64 forms a void in which a thermal management system can be located to thermally manage the shared air space. The thermal management system may comprise, for example, a chilled water system, a heating, ventilating and cooling (HVAC) system, or the like. The roof 64 includes one or more removable panels 66 that can be used to access the thermal management system after the roof 64 has been mounted to the ESC module 10. The roof 64 includes a plurality of connection members 68 that form openings and that are located at positions to align with openings in the top perimeter frame 14. In some embodiments, the ESC modules 10 can be stacked, and the ESC modules 10 may include a mating structure to support another vertically positioned ESC module 10.

[0032] Figure 5 illustrates the roof 64 coupled to the frame 12 according to one embodiment. Note that the connection members 68 are fixed to the top perimeter frame 14 to fix the roof 64 to the frame 12. A gasket (not illustrated) may be positioned about a top edge of the top perimeter frame 14 between the roof 64 and the top perimeter frame 14 to form a seal.

[0033] Figure 6 illustrates an enlarged portion of the ESC module 10 at a location where the roof 64 is fixed to the frame 12 according to one embodiment. In this example, the connection member 68 is coupled to the top perimeter frame 14 via two bolts 70.

5 **[0034]** Figure 7 illustrates the ESC module 10 with a plurality of panels 72 coupled to the ESC module 10. The panels 72 allow a human to access energy storage components that are maintained in the ESC module 10 and eliminate a need to include a void or center aisle in the ESC module 10 that can accommodate a human. The panels 72 also include a seal (not illustrated) to
10 seal the air space in the internal volume of the ESC module 10 from the exterior environment. The panels 72 may comprise, by way of non-limiting example, doors, hatches, curtains, covers, grills, ports, and the like. Among other advantages, by making the ESC module 10 not human-occupiable, the ESC module 10 can be substantially smaller than conventional energy storage
15 systems, and need not comply with ordinances regarding habitable structures. The shelving kits 42, 52, in some embodiments, comprise back-to-back horizontal shelves, such that each horizontal shelf is configured to receive a plurality of energy storage components and configured to facilitate access to the plurality of energy storage components via one of the plurality of panels 72. In
20 some embodiments, however, the panels 72 on one side of the ESC module 10 may facilitate access to the energy storage components, and the panels 72 on the opposite side of the ESC module 10 may be used for maintenance, installation, and the like.

[0035] Figure 8 illustrates a first ESC module 10-1 and a second ESC module
25 10-2 positioned to be coupled together to form an ESC enclosure 74, according to one embodiment. The first and second ESC modules 10-1, 10-2 are substantially similar to and have the same attributes as the ESC module 10 discussed above. A gasket 76 is positioned between a first side portion 26-1 of the ESC module 10-1 and a second side portion 28-2 of the ESC module 10-2.
30 The gasket 76 can help eliminate air leakage in the shared air space of the ESC enclosure 74. A gasket 78 and an end panel 80 are positioned to be coupled to

a second side portion 28-1 of the ESC module 10-1. A gasket 82, an end panel 84, and a power module 86 is positioned to be coupled to the first side portion 26-2 of the ESC module 10-2. The power module 86 is configured to provide electrical connectivity to first power busses 58 from outside the shared air space.

5 The power module 86 may also house a control system that is coupled to the sensors 61-1 – 61-3, and that may, based on data received from one or more of the sensors 61-1 – 61-3, perform certain actions, such as communicating alerts, and the like. The power module 86 may also include rack-level power conversion and power conversion integrated as part of the ESC enclosure 74
10 that aggregates more than one shelf of energy storage components.

[0036] In one embodiment, the ESC enclosure 74 is completely sealed from the exterior environment, preventing water, insects, and air from entering the shared air space. The ESC enclosure 74 also contains any fluids that may have leaked from an energy storage component.

15 **[0037]** Figure 9 illustrates a section of the ESC enclosure 74 at a location wherein the first ESC module 10-1 is coupled to the second ESC module 10-2. The first side portion 26-1 has a plurality of side fastening mechanisms in the form of a plurality of openings 88. Similarly, the second side portion 28-2 has a plurality of side fastening mechanisms in the form of a plurality of openings 90.
20 When positioned adjacent to one another the plurality of openings 88 align with the plurality of openings 90. A plurality of fastening mechanisms, such as bolts 92, may be inserted through the plurality of openings 88 and the plurality of openings 90 to couple the ESC module 10-1 to the ESC module 10-2.

[0038] In one embodiment, the gasket 76 forms a plurality of openings that
25 align with the openings 88 in the first side portion 26-1 of the first ESC module 10-1 and with the openings 90 in the second side portion 28-2 of the second ESC module 10-2 to facilitate passage of corresponding fastening mechanisms such as the bolts 92 through the first side portion 26-1, the gasket 76, and the second side portion 28-2.

30 **[0039]** Figure 10 illustrates a section of the ESC enclosure 74 at a location wherein the gasket 82 and the end panel 84 are coupled to the first side portion

26-2 of the ESC module 10-2. The power module 86 has been omitted for purposes of clarity. The first side portion 26-2 forms a plurality of openings 94 that are aligned with openings 96 formed in the end panel 84 to facilitate coupling of the end panel 84 to the first side portion 26-2 via a plurality of bolts 98.

5 **[0040]** Figure 11 illustrates the formed ESC enclosure 74. The ESC enclosure 74 includes a plurality of the removable panels 72 that are coupled completely about the perimeter of the ESC enclosure 74, and facilitate access to energy storage components stored therein. The ESC enclosure 74 forms a single shared air space that can be monitored by sensors, and thermally
10 managed as a whole. The ESC enclosure 74 may be easily extended by, for example, removing the end panel 80 (Figure 8) and coupling another ESC module 10 to the ESC module 10-1.

[0041] Figure 12 illustrates the ESC enclosure 74 illustrated in Figure 11 without any panels so that certain internal features of the ESC enclosure 74 can
15 be viewed. Among other features, Figure 12 illustrates a power bus 58-1 of the ESC module 10-1 and a power bus 58-2 of the ESC module 10-2 in a shared air space 100. The power busses 58-1, 58-2 are electrically coupled together and terminate in the power module 86 where electrical connectivity to the power
20 busses 58-1, 58-2 is provided outside the shared air space 100 of the ESC enclosure 74.

[0042] Figure 13 illustrates an enlarged first portion of Figure 12 according to one embodiment. The power busses 58-2 are coupled to first ends of a corresponding plurality of bus bar extensions 102. Second ends of the bus bar
25 extensions 102 are coupled to corresponding prongs (not illustrated) that extend from the power module 86, and provide electrical connectivity between the power busses 58-2 and the power module 86. In other embodiments, prongs extend a sufficient distance from the power module 86 to facilitate direct coupling to the power busses 58-2. A sensor 61 senses a characteristic of the shared air space
30 100. The sensor 61 is communicatively coupled to a control system, which is housed in the power module 86 and which may perform actions based on data generated by the sensor 61.

[0043] Figure 14 illustrates an enlarged second portion of Figure 12 according to one embodiment. A plurality of power busses 58-1 of the ESC module 10-1 are coupled to a corresponding plurality of power busses 58-2 of the ESC module 10-2 by a plurality of bus bar extensions 102. If additional ESC modules 5 10 are subsequently added to the ESC enclosure 74, the power busses 58-1, 58-2 may be electrically coupled to power busses of such additional ESC modules 10 in a similar manner.

[0044] Figure 15 is a flowchart of a method for assembling the ESC enclosure 74 according to one embodiment. Figure 15 will be discussed in conjunction with 10 Figure 8. Initially, a quantity of energy storage components to be enclosed is determined (Figure 15, block 1000). The quantity may be based, for example, on a total amount of energy storage that is desired, the particular characteristics of the energy storage components, and any other suitable criteria. A particular shelving kit style of a plurality of different shelving kit styles is selected based on 15 a type of energy storage component to be enclosed (Figure 15, block 1002). For example, if the energy storage components comprise lithium ion batteries, the first style 40 (Figure 2) may be selected. If the energy storage components comprise lead acid batteries, the second style 50 (Figure 3) may be selected. A number N greater than 1 of a plurality of ESC modules 10 required to enclose the 20 quantity of energy storage components based on the shelving kit style is determined (Figure 15, block 1004). This involves determining how many energy storage components the particular shelving kit style can maintain. For example, if a particular shelving kit style can maintain 100 energy storage components and the desired quantity of energy storage components to maintain is 150, then two 25 ESC modules 10 are required.

[0045] The N number (in this example two) of ESC modules 10 are placed adjacent to one another (Figure 15, block 1006). Each ESC module 10 includes at least one side portion that is configured to be coupled to a side portion of an adjacent ESC module 10. A shelving kit of the particular shelving kit style is 30 inserted into each ESC module 10 (Figure 15, block 1008). The N number of ESC modules 10 are coupled together via respective side portions to form the

ESC enclosure 74 (Figure 15, block 1010). One or more roofs 64 are mounted on the ESC enclosure 74 (Figure 15, block 1012). A plurality of panels 72 is coupled completely about a perimeter of the ESC enclosure 74 to form an enclosed shared air space 100 within the ESC enclosure 74 (Figure 15, block 5 1014).

[0046] Those skilled in the art will recognize improvements and modifications to the preferred embodiments of the disclosure. All such improvements and modifications are considered within the scope of the concepts disclosed herein and the claims that follow.

CLAIMS

What is claimed is:

1. A method for assembling an energy storage component (ESC) enclosure
5 comprising:
 - determining a quantity of energy storage components to be enclosed;
 - selecting a particular shelving kit style of a plurality of different shelving kit styles based on a type of energy storage component to be enclosed;
 - determining a number N greater than 1 of a plurality of ESC modules
10 required to enclose the quantity of energy storage components based on the shelving kit style;
 - placing the N number of the plurality of ESC modules adjacent to one another, each ESC module including at least one side portion that is configured to be coupled to a side portion of an adjacent ESC module;
 - 15 inserting into each ESC module of the N number of the plurality of ESC modules a shelving kit of the particular shelving kit style;
 - coupling the N number of the plurality of ESC modules together via respective side portions to form an ESC enclosure;
 - mounting a roof on the ESC enclosure; and
 - 20 coupling a plurality of panels completely about a perimeter of the ESC enclosure to form an enclosed shared air space within the ESC enclosure.

2. The method of claim 1, further comprising:
 - positioning a gasket between a first side portion of a first ESC module of
25 the plurality of ESC modules and a second side portion of a second ESC module of the plurality of ESC modules.

3. The method of claim 2, further comprising:
 - wherein positioning the gasket between the first side portion of the first
30 ESC module of the plurality of ESC modules and the second side portion of the second ESC module of the plurality of ESC modules further comprises

positioning the gasket between the first side portion of the first ESC module of the plurality of ESC modules and the second side portion of the second ESC module of the plurality of ESC modules, the gasket forming a plurality of openings that align with corresponding openings in the first side portion of the first ESC module and the second side portion of the second ESC module to facilitate passage of corresponding fastening mechanisms through the first side portion of the first ESC module, the gasket, and the second side portion of the second ESC module.

- 5
- 10 4. The method of claim 1, further comprising:
coupling a control system to an end of the ESC enclosure;
mounting a sensor in the shared air space, the sensor identifying a characteristic of the shared air space; and
coupling the sensor to the control system.
- 15
5. The method of claim 4, wherein the sensor comprises one of a smoke sensor, a hydrogen sensor, a humidity sensor, a temperature sensor, and a gas sensor.
- 20 6. The method of claim 1, wherein a first ESC module of the plurality of ESC modules comprises a top perimeter frame and a bottom perimeter frame, and wherein inserting into each ESC module of the N number of the plurality of ESC modules the shelving kit of the particular shelving kit style further comprises:
inserting a first shelving kit into a first ESC module, the first shelving kit
25 comprising a plurality of upright members, each upright member having a top end and a bottom end;
coupling the top end of each upright member to the top perimeter frame to fix the first shelving kit with respect to the top perimeter frame; and
coupling the bottom end of each upright member to the bottom perimeter
30 frame to fix the first shelving kit with respect to the bottom perimeter frame.

7. The method of claim 1, wherein a first ESC module of the plurality of ESC modules comprises a central upright structure, a first side, and a second side, the central upright structure comprising a plurality of upright members that extend from a top perimeter frame of the first ESC module to a bottom perimeter frame of the first ESC module, the first side including a plurality of first side members that extend from the top perimeter frame to the bottom perimeter frame, the second side including a plurality of second side members that extend from the top perimeter frame to the bottom perimeter frame, and wherein inserting into each ESC module of the N number of the plurality of ESC modules the shelving kit of the particular shelving kit style comprises:

inserting a first shelving kit into the first ESC module, the first shelving kit comprising a plurality of shelves, each shelf of the plurality of shelves having a first end member configured to be coupled to the central upright structure and a second end member configured to be coupled to either the first side members or the second side members;

coupling the first end members of the plurality of shelves to the central upright structure to fix the first end members with respect to the central upright structure; and

coupling the second end members to either the plurality of first side members or the plurality of second side members to fix the second end members with respect to either the plurality of first side members or the plurality of second side members.

8. The method of claim 1, wherein a first ESC module comprises a first power bus and a second ESC module comprises a second power bus, and further comprising:

electrically coupling the first power bus to the second power bus.

9. The method of claim 8, wherein electrically coupling the coupling the first power bus to the second power bus comprises coupling a first end of a bus bar

extension to the first power bus and a second end of the bus bar extension to the second power bus.

10. The method of claim 8, further comprising:

- 5 coupling a power module to an end of the ESC enclosure; and
 coupling the first power bus to the power module;
 wherein the power module is configured to provide electrical connectivity
to the first power bus from outside the shared air space.

10 11. The method of claim 1, wherein the energy storage components comprise
batteries.

12. The method of claim 1, wherein the ESC enclosure is devoid of a center
aisle.

15

13. The method of claim 11, wherein each ESC module has a length and a
width, and each shelving kit comprises back-to-back horizontal shelves, each
horizontal shelf configured to receive a plurality of energy storage components
and configured to facilitate access to the plurality of energy storage components
20 via one of the plurality of panels.

14. The method of claim 1, wherein mounting the roof on the ESC enclosure
further comprises mounting a roof on each ESC module.

25 15. The method of claim 1, further comprising mounting a thermal
management system in at least one ESC module of the plurality of ESC modules,
the thermal management system configured to thermally manage the ESC
enclosure.

30 16. The method of claim 15, wherein the roof comprises a panel, and further
comprising accessing the thermal management system via the panel.

17. An energy storage component (ESC) enclosure comprising:
a plurality of ESC modules, each ESC module including at least one side
portion having a plurality of side fastening mechanisms configured to be coupled
5 to an adjacent ESC module, wherein the plurality of ESC modules is coupled
together via the plurality of side fastening mechanisms to form an ESC
enclosure;

a plurality of shelving kits, each shelving kit mounted to one of the ESC
modules;

10 a roof coupled to the plurality of ESC modules; and

a plurality of panels coupled to the plurality of ESC modules about a
perimeter of the ESC enclosure to form a shared air space within the ESC
enclosure.

15 18. The ESC enclosure of claim 17, wherein a first ESC module of the plurality
of ESC modules comprises a top perimeter frame and a bottom perimeter frame,
and wherein a first shelving kit of the plurality of shelving kits comprises a
plurality of upright members, each upright member having a top end and a
bottom end;

20 wherein the top end of each upright member is coupled to the top
perimeter frame to fix the first shelving kit with respect to the top perimeter frame;
and

25 wherein the bottom end of each upright member is coupled to the bottom
perimeter frame to fix the first shelving kit with respect to the bottom perimeter
frame.

19. The ESC enclosure of claim 17, wherein a first ESC module comprises a
first power bus and a second ESC module comprises a second power bus, and
wherein the first power bus is electrically coupled to the second power bus via a
30 bus bar extension.

20. The ESC enclosure of claim 17, further comprising:
a control system coupled to an end of the ESC enclosure; and
a sensor mounted in the shared air space, the sensor configured to
identify a characteristic of the shared air space; and

5 wherein the sensor is communicatively coupled to the control system.

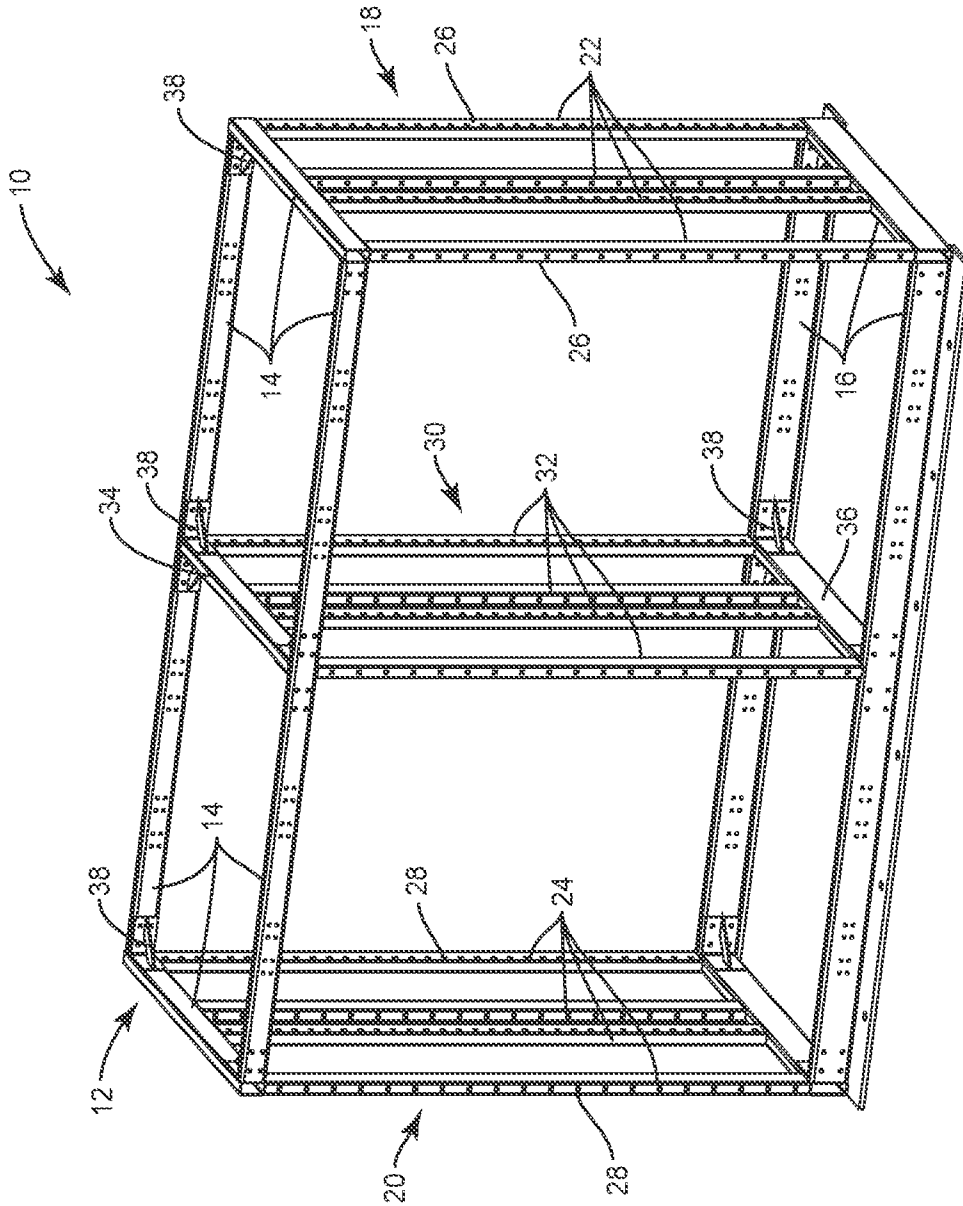

FIG. 1

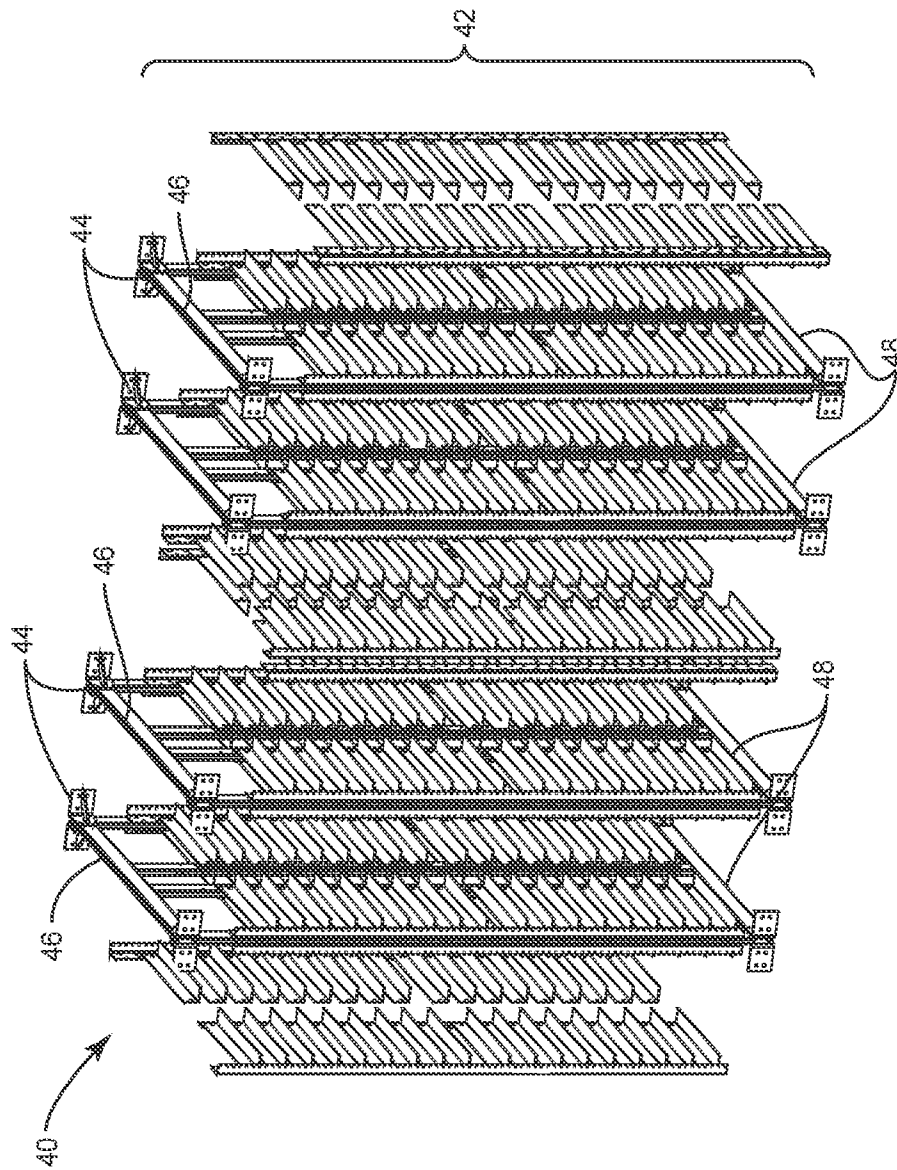

FIG. 2

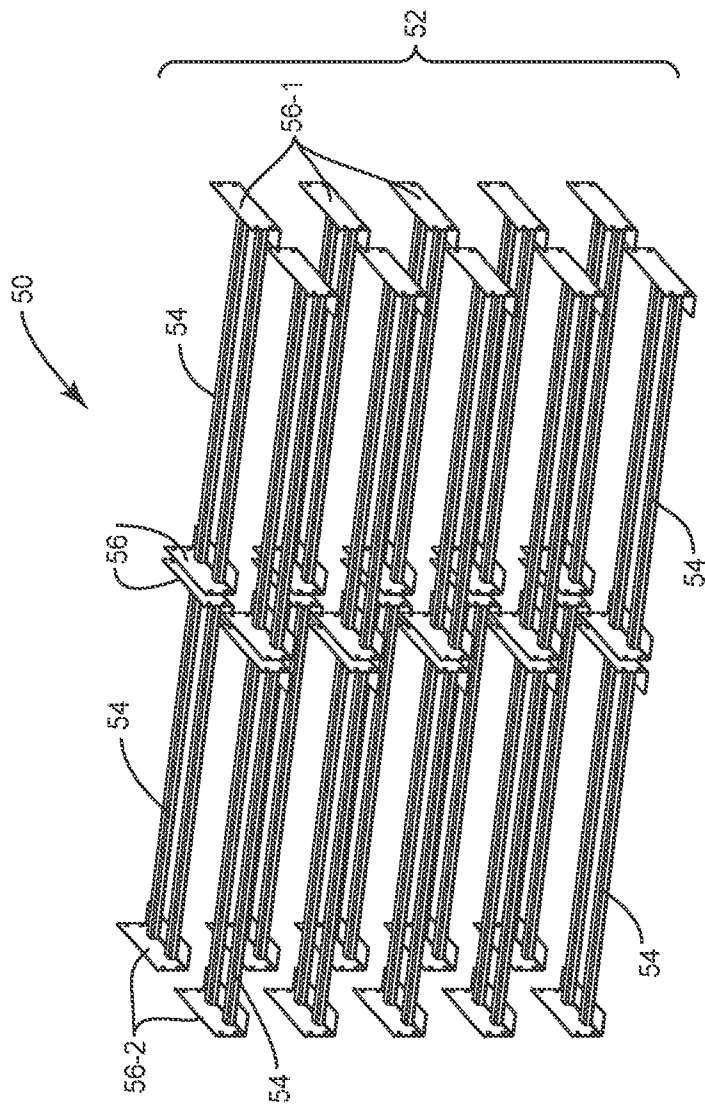

FIG. 3

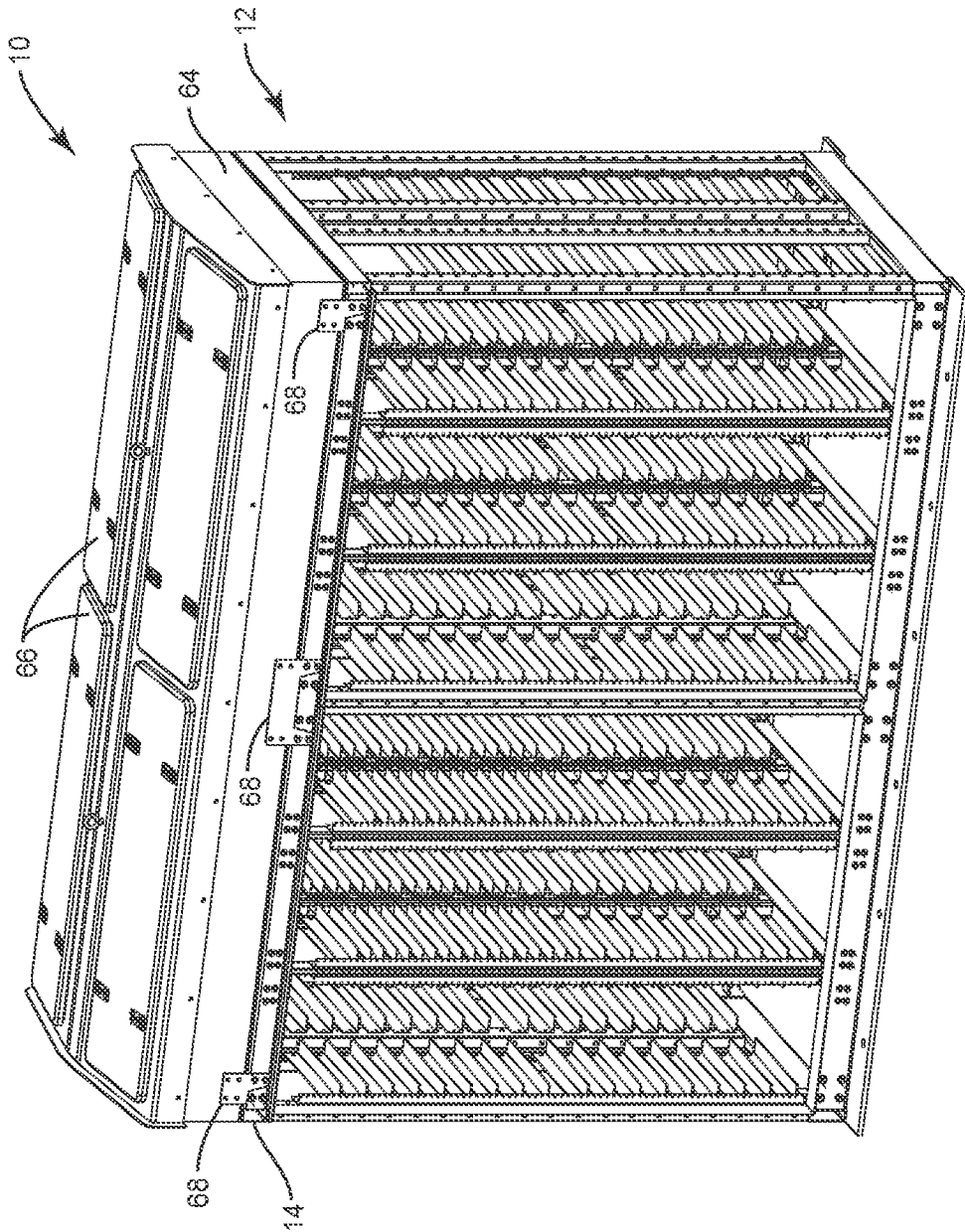

FIG. 5

6/15

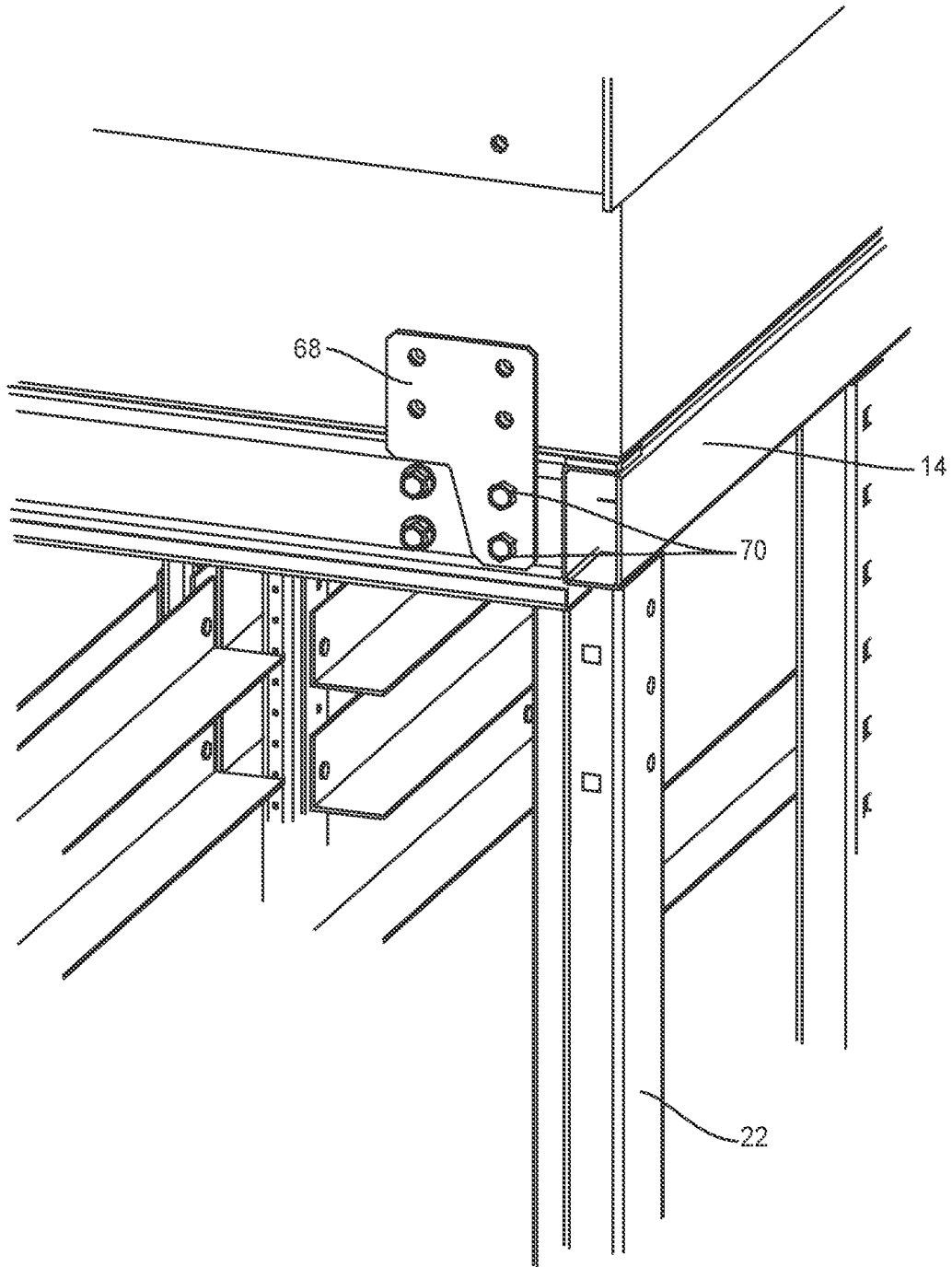

FIG. 6

7/15

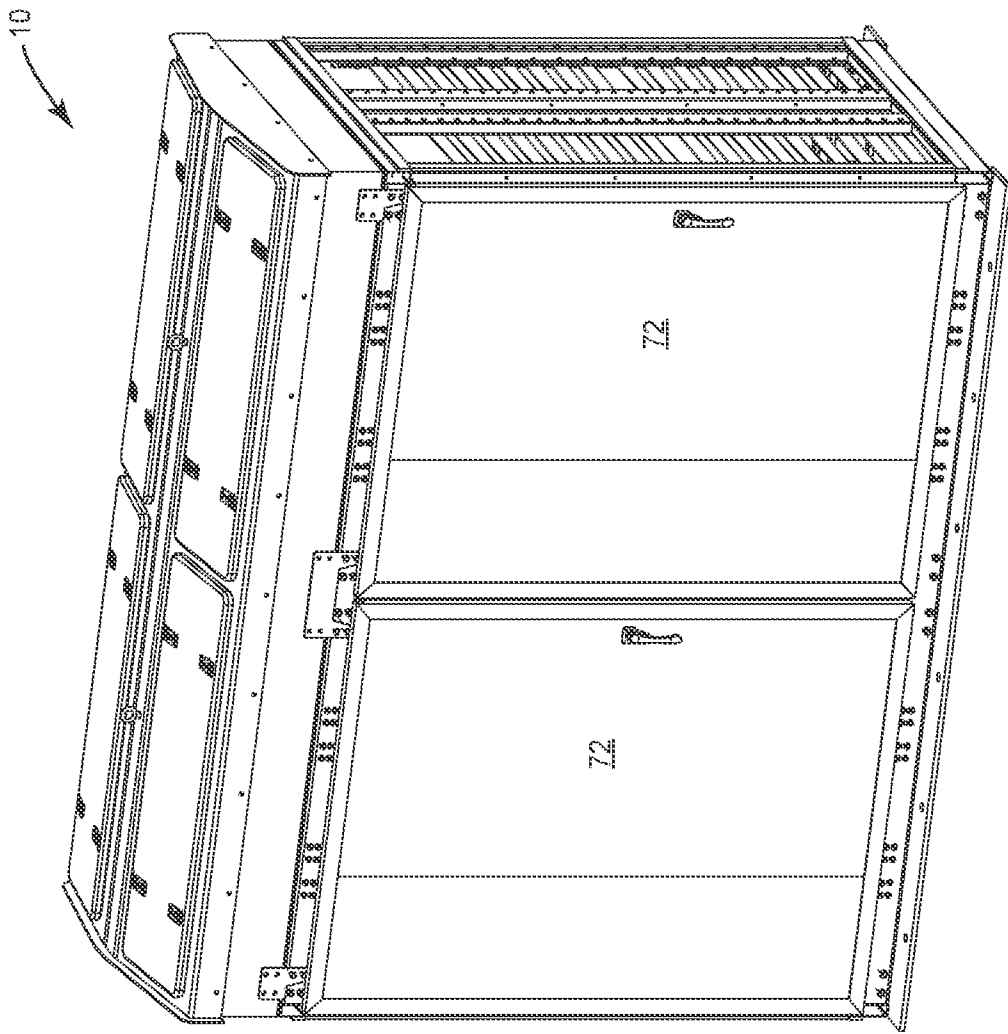

FIG. 7

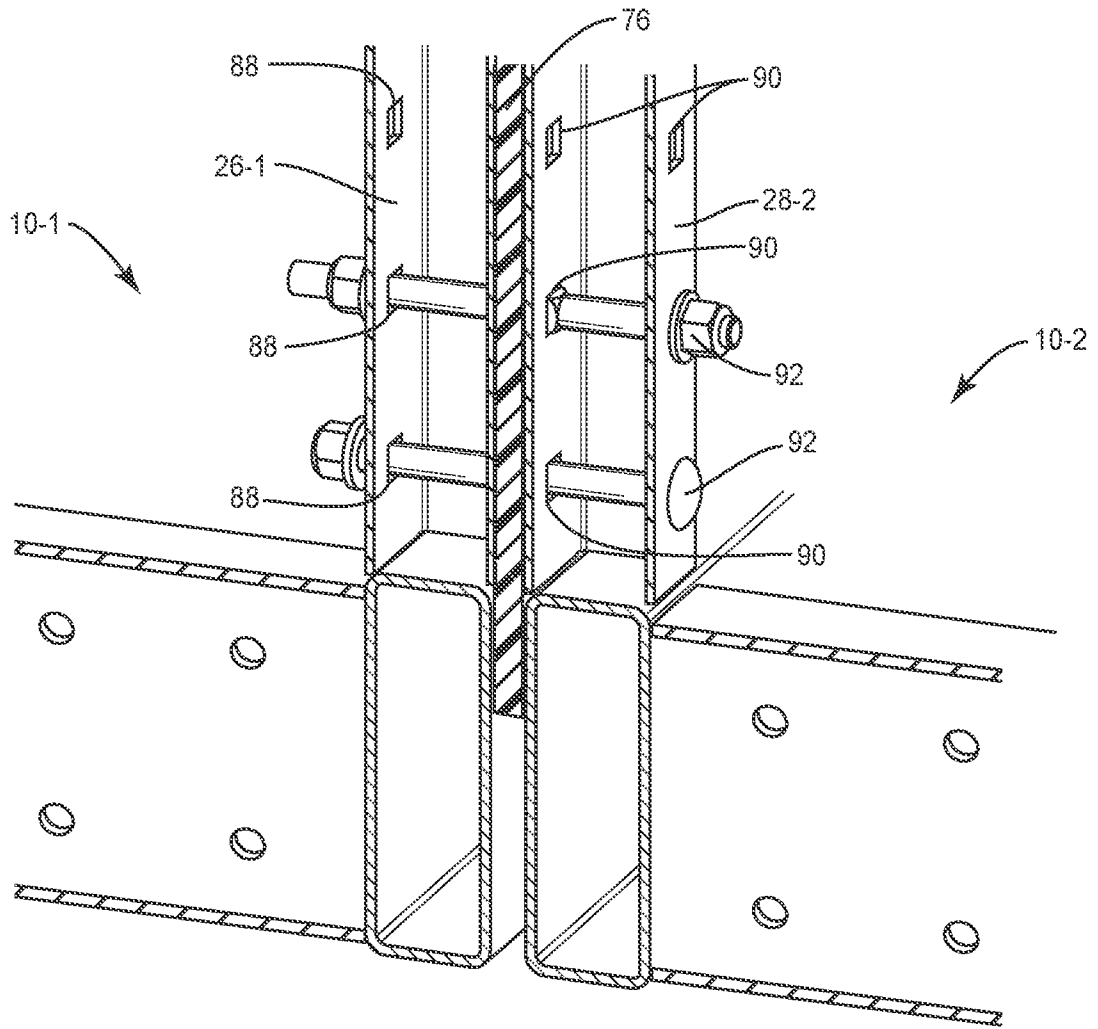

FIG. 9

10/15

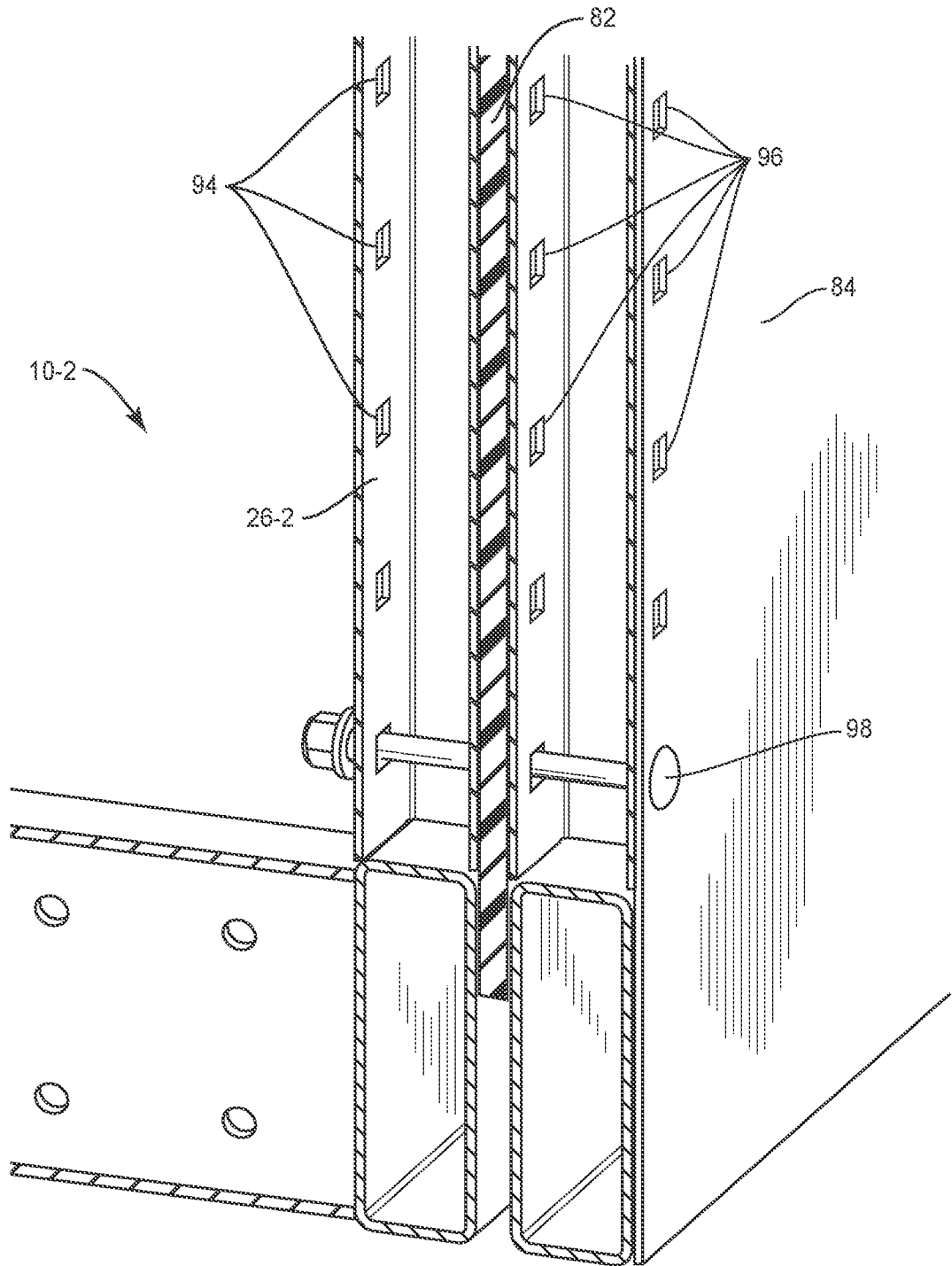

FIG. 10

11/15

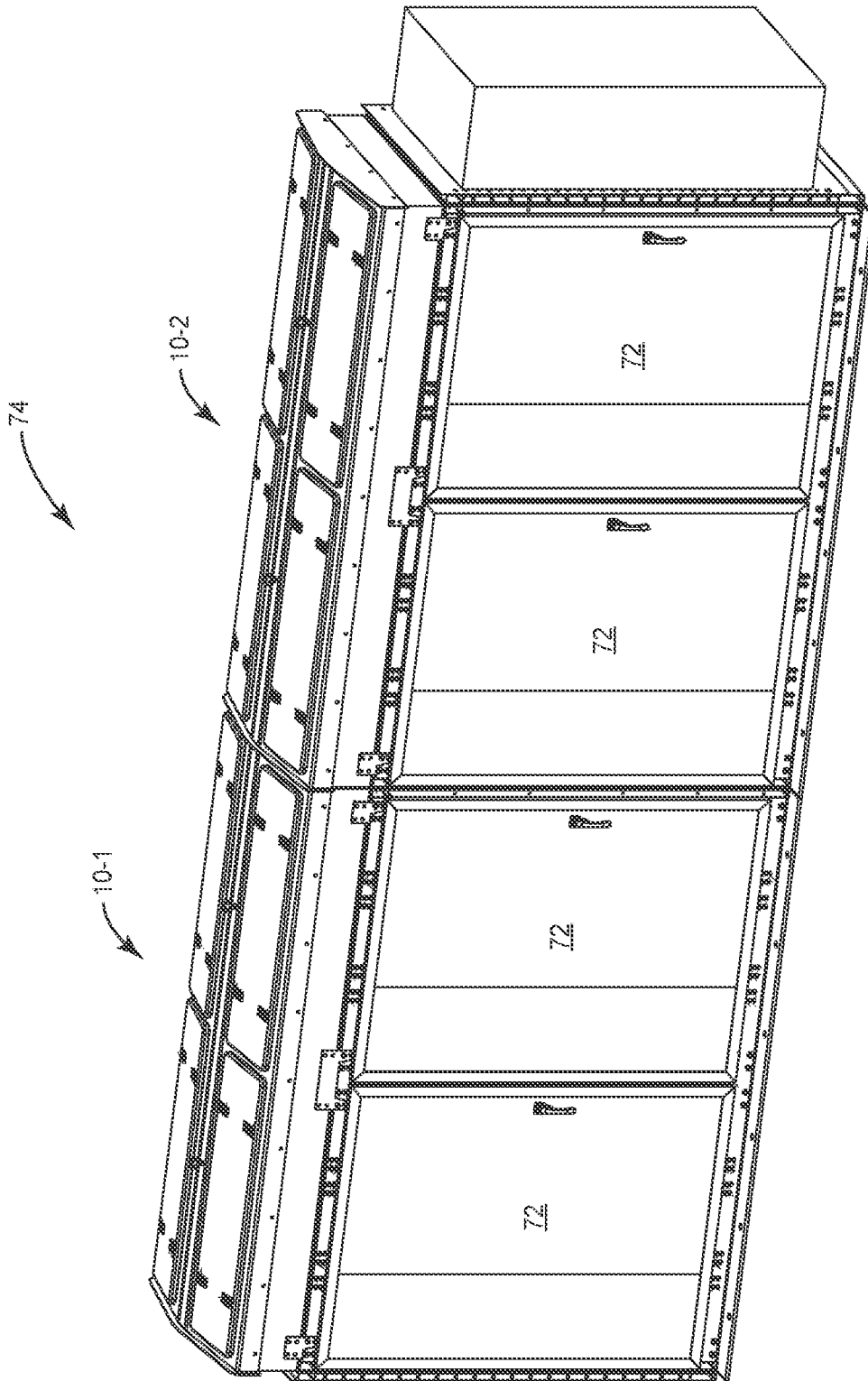

FIG. 11

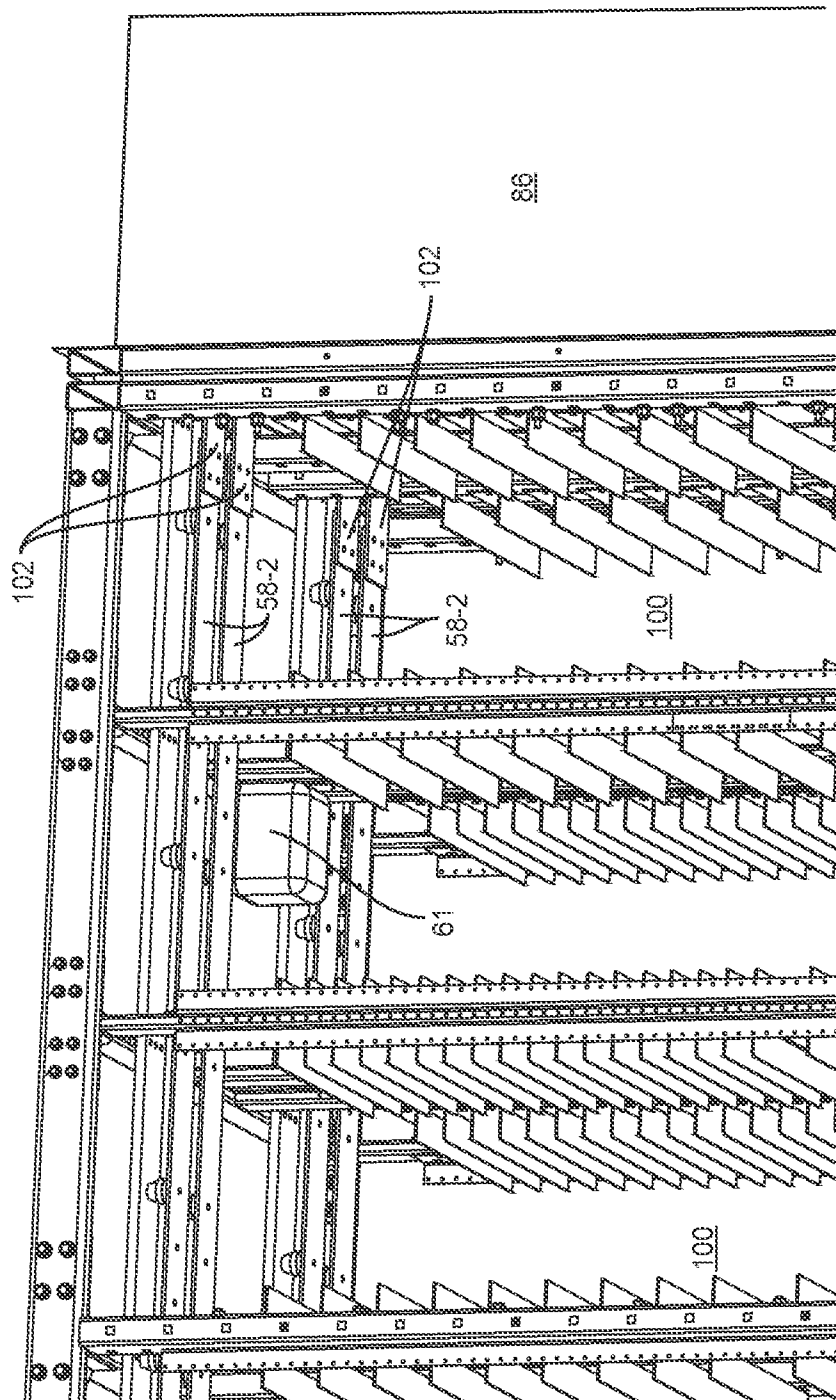

FIG. 13

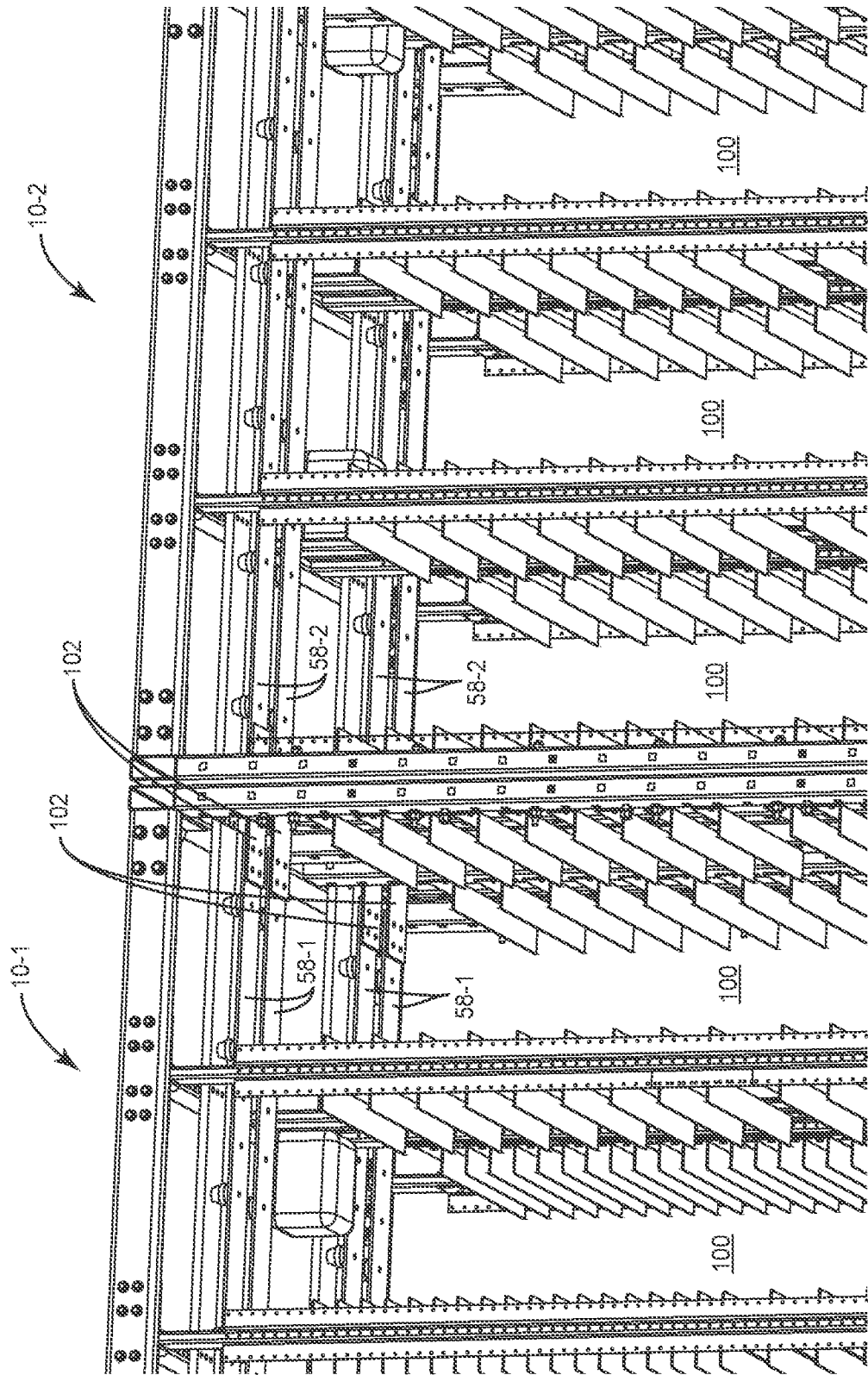
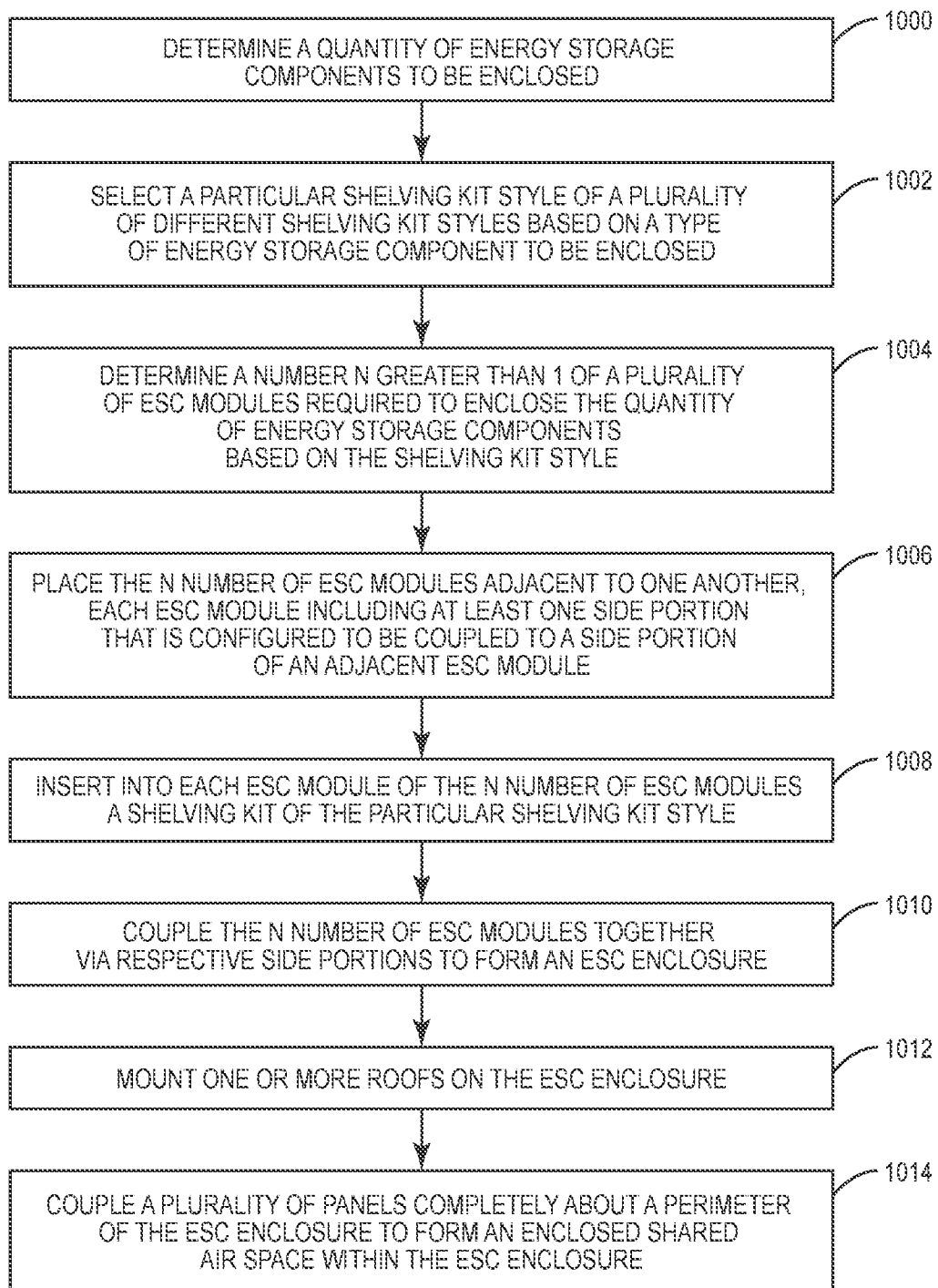

FIG. 14

15/15

**FIG. 15**

A. CLASSIFICATION OF SUBJECT MATTER**H01M 2/10(2006.01)i, H01M 10/42(2006.01)i, H01M 10/48(2006.01)i, H01M 2/20(2006.01)i**

According to International Patent Classification (IPC) or to both national classification and IPC

B. FIELDS SEARCHED

Minimum documentation searched (classification system followed by classification symbols)

H01M 2/10; H01M 10/50; A47B 45/00; H05K 5/00; H01M 2/00; H01M 10/42; H01M 10/48; H01M 2/20

Documentation searched other than minimum documentation to the extent that such documents are included in the fields searched

Korean utility models and applications for utility models

Japanese utility models and applications for utility models

Electronic data base consulted during the international search (name of data base and, where practicable, search terms used)

eKOMPASS(KIPO internal) & Keywords: battery, module, frame, case, bousing, shelf, shelves, rack, tray

C. DOCUMENTS CONSIDERED TO BE RELEVANT

Category*	Citation of document, with indication, where appropriate, of the relevant passages	Relevant to claim No.
X	US 7548429 B2 (MILLER, R. L.) 16 June 2009 See columns 3, 4, 8; claims 1, 14; figures 1, 11.	17-19
Y		20
A		1-16
Y	US 2014-0360207 A1 (KIA MOTORS CORPORATION et al.) 11 December 2014 See claims 1, 6.	20
A	US 2015-0359329 A1 (ENVIRONMENTAL COMPLIANCE SOLUTIONS, LLC) 17 December 2015 See the whole documnet.	1-20
A	US 2013-0065087 A1 (KIM, B. et al.) 14 March 2013 See the whole document.	1-20
A	JP 60-236454 A (FUJITSU LTD.) 25 November 1985 See the whole document.	1-20

 Further documents are listed in the continuation of Box C. See patent family annex.

* Special categories of cited documents:

"A" document defining the general state of the art which is not considered to be of particular relevance

"E" earlier application or patent but published on or after the international filing date

"L" document which may throw doubts on priority claim(s) or which is cited to establish the publication date of another citation or other special reason (as specified)

"O" document referring to an oral disclosure, use, exhibition or other means

"P" document published prior to the international filing date but later than the priority date claimed

"T" later document published after the international filing date or priority date and not in conflict with the application but cited to understand the principle or theory underlying the invention

"X" document of particular relevance; the claimed invention cannot be considered novel or cannot be considered to involve an inventive step when the document is taken alone

"Y" document of particular relevance; the claimed invention cannot be considered to involve an inventive step when the document is combined with one or more other such documents, such combination being obvious to a person skilled in the art

"&" document member of the same patent family

Date of the actual completion of the international search

20 July 2017 (20.07.2017)

Date of mailing of the international search report

20 July 2017 (20.07.2017)

Name and mailing address of the ISA/KR

International Application Division

Korean Intellectual Property Office

189 Cheongsa-ro, Seo-gu, Daejeon, 35208, Republic of Korea

Facsimile No. +82-42-481-8578

Authorized officer

MIN, In Gyou

Telephone No. +82-42-481-3326

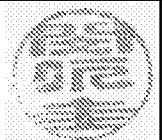

INTERNATIONAL SEARCH REPORT

Information on patent family members

International application No.

PCT/US2017/026529

Patent document cited in search report	Publication date	Patent family member(s)	Publication date
US 7548429 B2	16/06/2009	US 2005-0281002 A1 US 2006-0152906 A1	22/12/2005 13/07/2006
US 2014-0360207 A1	11/12/2014	KR 10-1526389 B1 KR 10-2014-0144802 A	05/06/2015 22/12/2014
US 2015-0359329 A1	17/12/2015	CA 2894345 A1 US 2017-077470 A1 US 9504319 B2	13/12/2015 16/03/2017 29/11/2016
US 2013-0065087 A1	14/03/2013	CN 103000838 A JP 2013-058478 A JP 6103860 B2 KR 10-1363792 B1 KR 10-2013-0027993 A US 8900737 B2	27/03/2013 28/03/2013 29/03/2017 21/02/2014 18/03/2013 02/12/2014
JP 60-236454 A	25/11/1985	None	