



US00D445738S

(12) **United States Design Patent**  
**Lindenman et al.**

(10) **Patent No.:** **US D445,738 S**

(45) **Date of Patent:** **\*\* Jul. 31, 2001**

(54) **TRAILER HITCH RECEIVER ASSEMBLY WITH TOWING ACCESSORY PORTS**

(75) Inventors: **Thomas W. Lindenman**, South Bend;  
**Richard W. McCoy**, Granger, both of  
IN (US)

(73) Assignee: **Reese Products, Inc.**, Elkhart, IN (US)

(\*\*) Term: **14 Years**

(21) Appl. No.: **29/133,011**

(22) Filed: **Nov. 20, 2000**

(51) **LOC (7) Cl.** ..... **12-16**

(52) **U.S. Cl.** ..... **D12/162**

(58) **Field of Search** ..... D12/162, 400;  
280/402, 415.1, 416.1, 482, 490.1, 493,  
495, 491.1-491.49, 500-501, 505, 511

(56) **References Cited**

**U.S. PATENT DOCUMENTS**

D. 268,574	*	4/1983	Hampton	.....	D12/162
D. 341,117	*	11/1993	Sundstedt	.....	D12/162
D. 373,557	*	9/1996	Shaw et al.	.....	D12/162
D. 379,343	*	5/1997	Shaw et al.	.....	D12/162
D. 420,631	*	2/2000	Shaw et al.	.....	D12/162
D. 424,989	*	5/2000	McCoy et al.	.....	D12/162
D. 424,990	*	5/2000	McCoy et al.	.....	D12/162
D. 427,118	*	6/2000	McCoy et al.	.....	D12/162
D. 431,504	*	10/2000	Hoska	.....	D12/162

D. 433,357	*	11/2000	McCoy et al.	.....	D12/162
D. 434,708	*	12/2000	McCoy et al.	.....	D12/162
4,159,833		7/1979	Meiners	.	
4,204,702		5/1980	Oltrogge	.	
4,318,501		3/1982	Graber	.	
4,326,730		4/1982	Tomen	.	
4,915,276		4/1990	Devito	.	
4,950,010		8/1990	Denny	.	
5,460,304		10/1995	Porter et al.	.	
5,476,279		12/1995	Klemetsen	.	
5,620,198		4/1997	Borchers	.	

\* cited by examiner

*Primary Examiner*—Stacia Cadmus

(74) *Attorney, Agent, or Firm*—King and Schickli, PLLC

(57) **CLAIM**

The ornamental design for a trailer hitch receiver assembly with towing accessory ports, as shown and described.

**DESCRIPTION**

FIG. 1 is a perspective view of the trailer hitch receiver assembly with towing accessory ports of the present invention;

FIG. 2 is a front elevational view thereof;

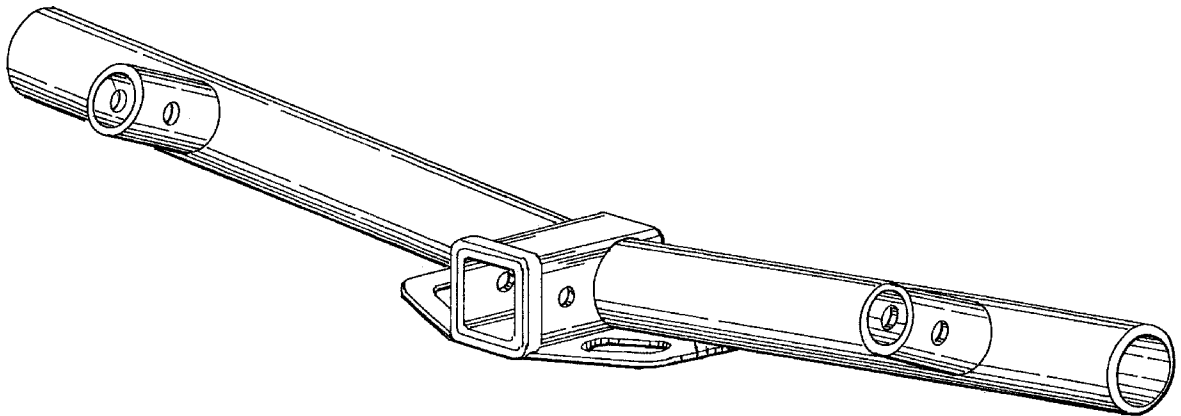
FIG. 3 is a rear elevational view thereof;

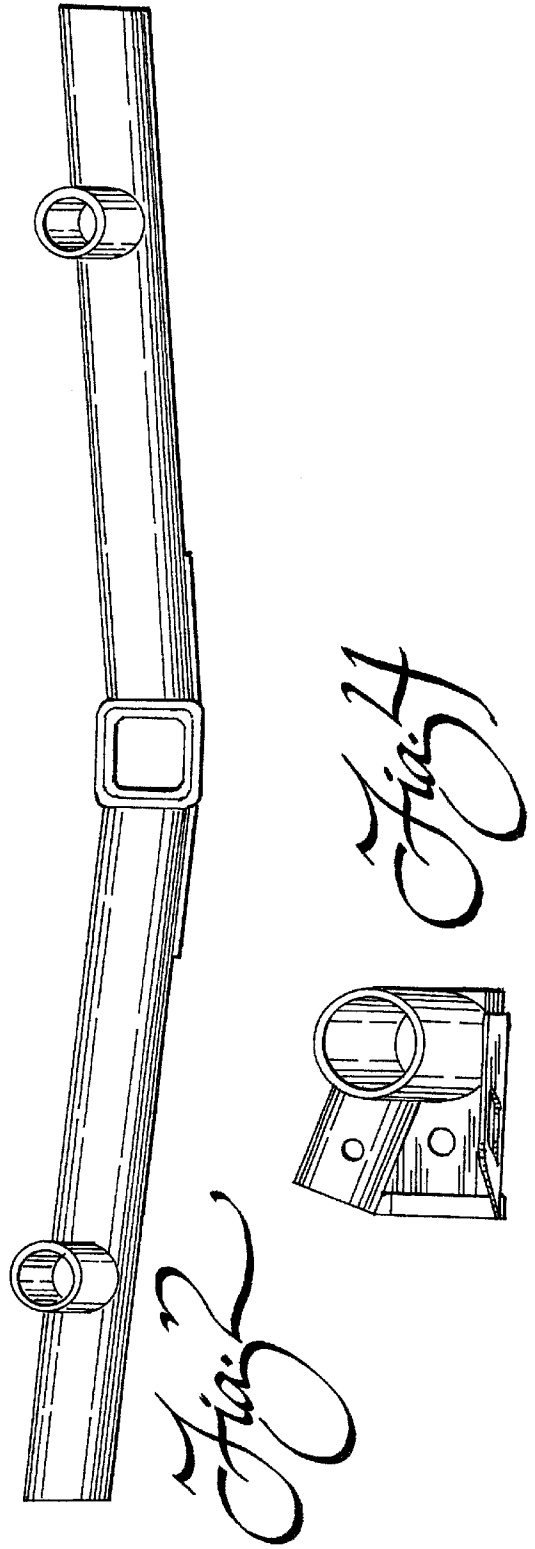
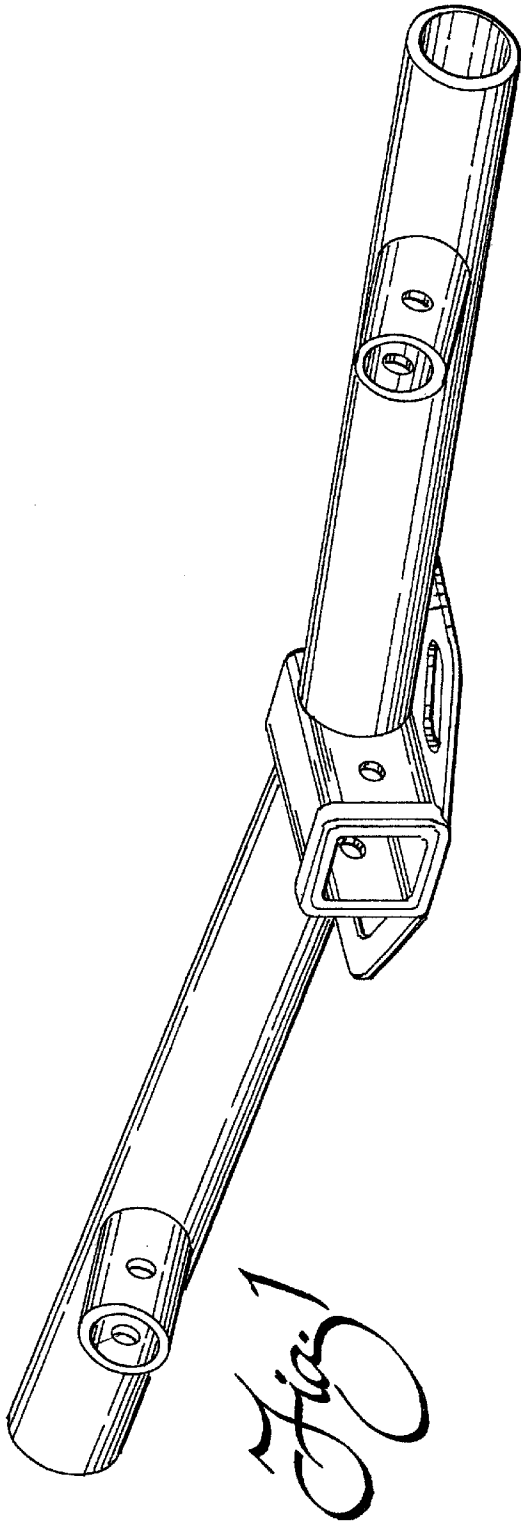
FIG. 4 is a right side elevational view, the left side elevational view being a substantial mirror image thereof;

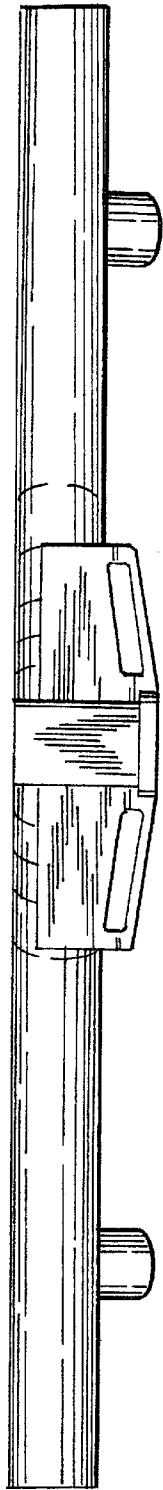
FIG. 5 is a top plan view thereof; and,

FIG. 6 is a bottom plan view thereof.

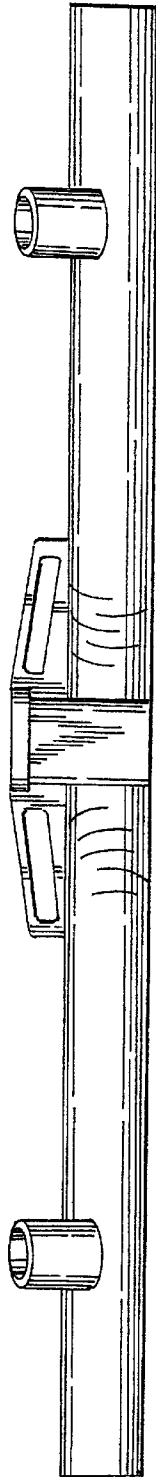
**1 Claim, 2 Drawing Sheets**



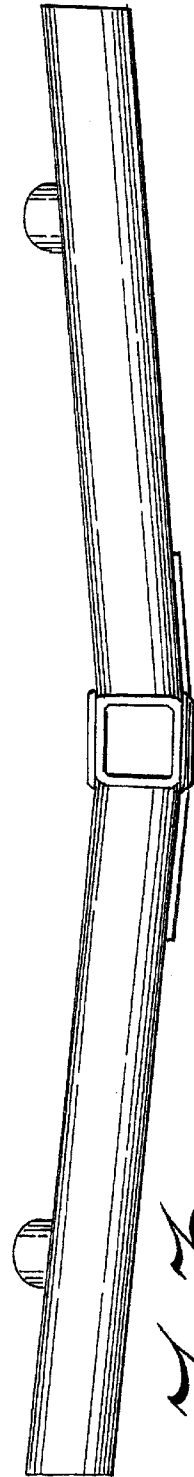




*Fig. 6*



*Fig. 5*



*Fig. 4*