

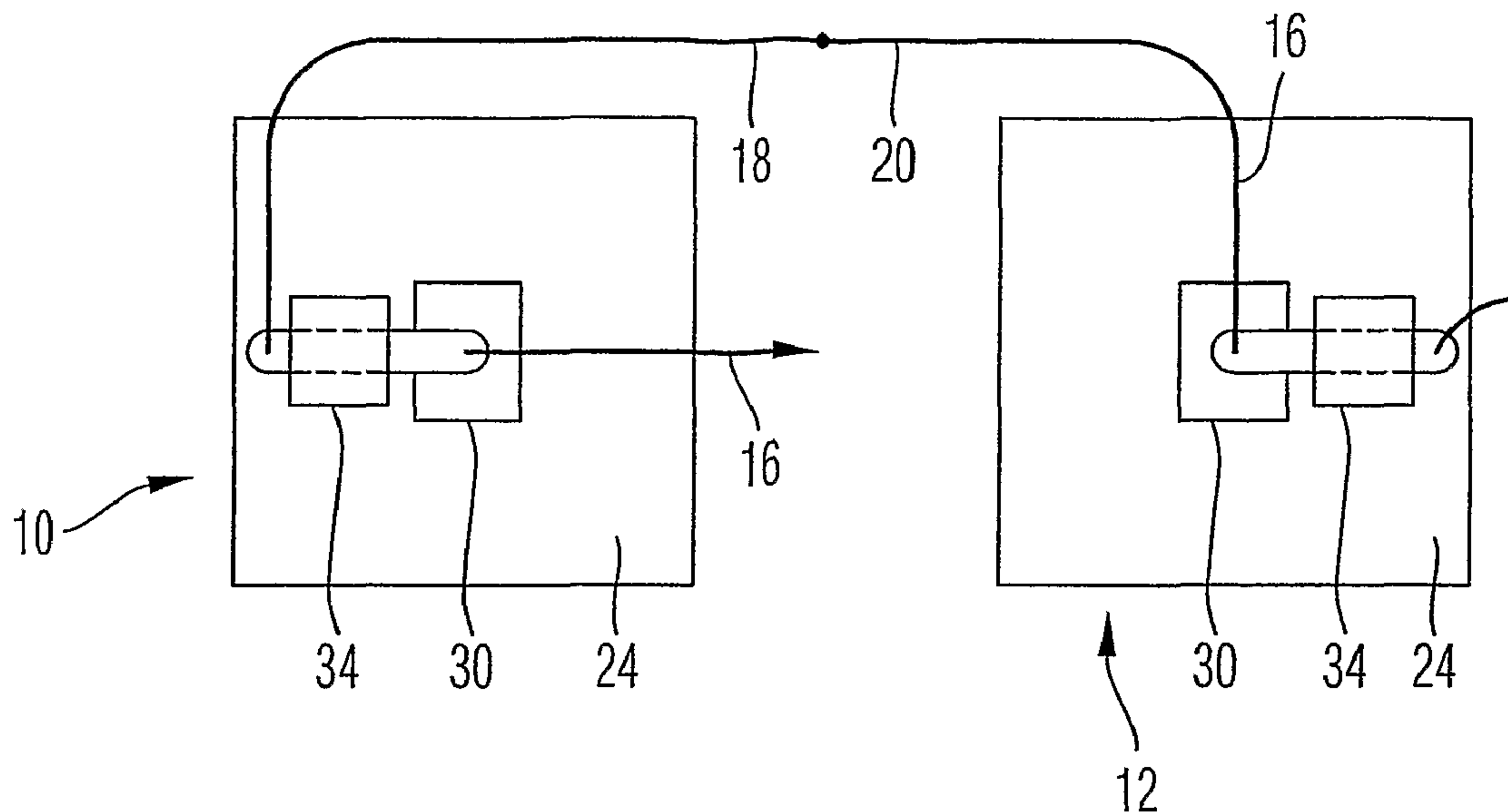

(86) Date de dépôt PCT/PCT Filing Date: 2004/12/21
 (87) Date publication PCT/PCT Publication Date: 2005/07/07
 (85) Entrée phase nationale/National Entry: 2006/06/01
 (86) N° demande PCT/PCT Application No.: EP 2004/014554
 (87) N° publication PCT/PCT Publication No.: 2005/061168
 (30) Priorité/Priority: 2003/12/22 (DE103 60 466.9)

(51) Cl.Int./Int.Cl. *B23K 9/133* (2006.01),
B65D 85/04 (2006.01), *B65H 49/12* (2006.01)
 (71) Demandeur/Applicant:
SIDERGAS SPA, IT
 (72) Inventeur/Inventor:
GELMETTI, CARLO, IT
 (74) Agent: SMART & BIGGAR

(54) Titre : COUVERCLE POUR RECEPTACLE DE FIL A SOUDER
 (54) Title: COVER FOR WELDING WIRE CONTAINER



(57) **Abrégé/Abstract:**

A cover (24) for a welding wire container (10,12) is shown, having an upper surface (26) provided with a slot (32) through which the welding wire (16) can be withdrawn from the container, and having spacing means (34) which define an inner portion (36) and an outer portion (38) of the slot such that welding wire extending through the inner portion of the slot is held spaced from welding wire extending through the outer portion of the slot.

(12) INTERNATIONAL APPLICATION PUBLISHED UNDER THE PATENT COOPERATION TREATY (PCT)

(19) World Intellectual Property
Organization
International Bureau



(43) International Publication Date
7 July 2005 (07.07.2005)

PCT

(10) International Publication Number
WO 2005/061168 A1

- (51) International Patent Classification⁷: **B23K 9/133**, B65H 49/12, B65D 85/04
- (21) International Application Number: PCT/EP2004/014554
- (22) International Filing Date: 21 December 2004 (21.12.2004)
- (25) Filing Language: English
- (26) Publication Language: English
- (30) Priority Data: 103 60 466.9 22 December 2003 (22.12.2003) DE
- (71) Applicant (for all designated States except US): **SIDER-GAS SPA** [IT/IT]; Viale Rimembranza 17, I-37010 S. Ambrogio di Valpolicella (IT).
- (72) Inventor; and
- (75) Inventor/Applicant (for US only): **GELMETTI, Carlo** [IT/IT]; Loc. Barum 66, I-37017 Lazise (IT).
- (74) Agent: **STIES, Jochen**; Prinz & Partner GbR, Manzingerweg 7, 81241 München (DE).
- (81) Designated States (unless otherwise indicated, for every kind of national protection available): AE, AG, AL, AM, AT, AU, AZ, BA, BB, BG, BR, BW, BY, BZ, CA, CH, CN, CO, CR, CU, CZ, DE, DK, DM, DZ, EC, EE, EG, ES, FI, GB, GD, GE, GH, GM, HR, HU, ID, IL, IN, IS, JP, KE, KG, KP, KR, KZ, LC, LK, LR, LS, LT, LU, LV, MA, MD, MG, MK, MN, MW, MX, MZ, NA, NI, NO, NZ, OM, PG, PH, PL, PT, RO, RU, SC, SD, SE, SG, SK, SL, SY, TJ, TM, TN, TR, TT, TZ, UA, UG, US, UZ, VC, VN, YU, ZA, ZM, ZW.
- (84) Designated States (unless otherwise indicated, for every kind of regional protection available): ARIPO (BW, GH, GM, KE, LS, MW, MZ, NA, SD, SL, SZ, TZ, UG, ZM, ZW), Eurasian (AM, AZ, BY, KG, KZ, MD, RU, TJ, TM), European (AT, BE, BG, CH, CY, CZ, DE, DK, EE, ES, FI, FR, GB, GR, HU, IE, IS, IT, LT, LU, MC, NL, PL, PT, RO, SE, SI, SK, TR), OAPI (BF, BJ, CF, CG, CI, CM, GA, GN, GQ, GW, ML, MR, NE, SN, TD, TG).
- Published:
— with international search report
- For two-letter codes and other abbreviations, refer to the "Guidance Notes on Codes and Abbreviations" appearing at the beginning of each regular issue of the PCT Gazette.

(54) Title: COVER FOR WELDING WIRE CONTAINER

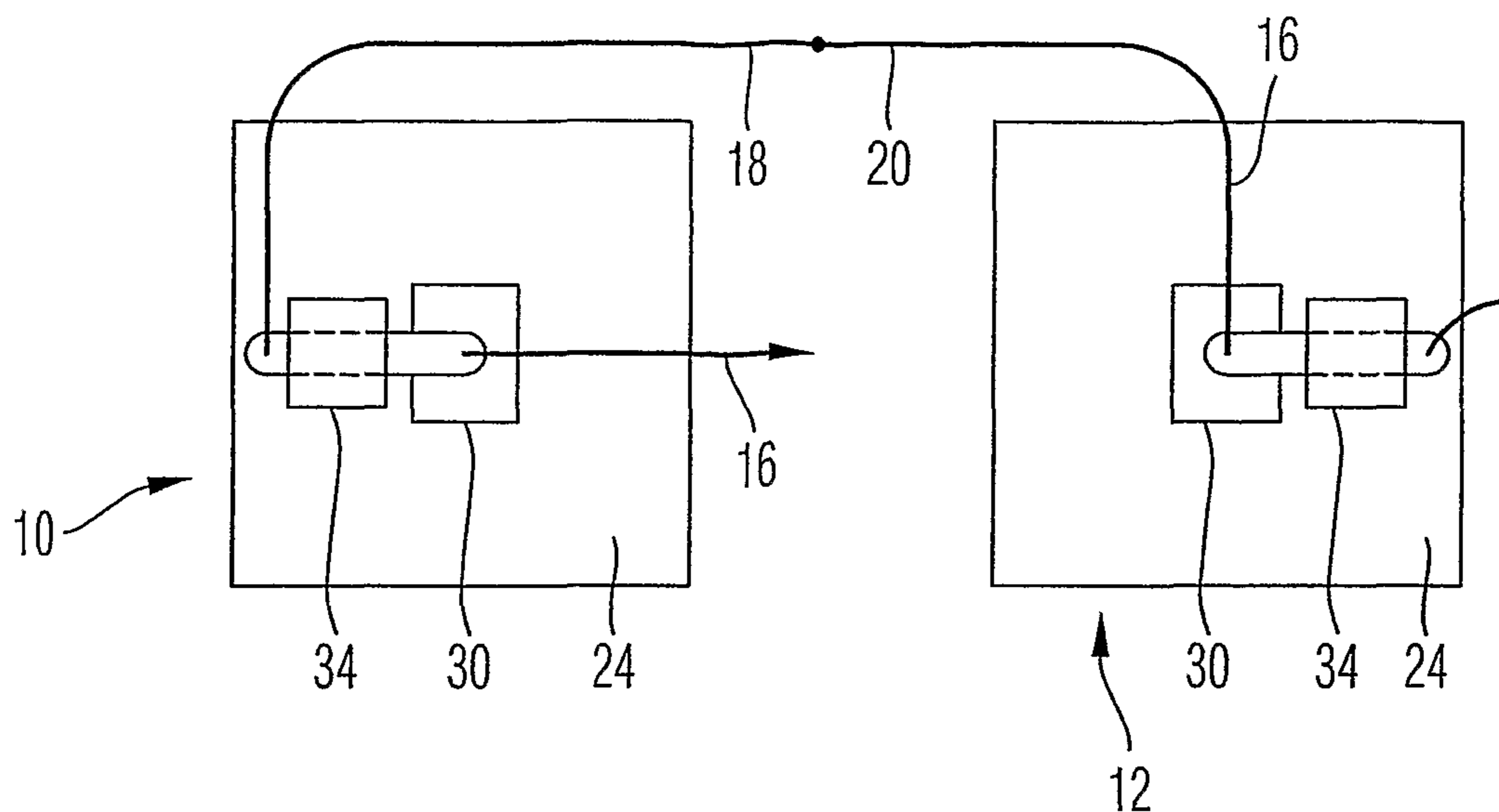

(57) Abstract: A cover (24) for a welding wire container (10,12) is shown, having an upper surface (26) provided with a slot (32) through which the welding wire (16) can be withdrawn from the container, and having spacing means (34) which define an inner portion (36) and an outer portion (38) of the slot such that welding wire extending through the inner portion of the slot is held spaced from welding wire extending through the outer portion of the slot.

WO 2005/061168 A1

Cover for Welding Wire Container

The invention relates to a cover for a welding wire container and to a welding wire container having a cover.

5 Welding wire for automatic welding machines is provided in coils, each coil being placed in a container. On top of the container, a cover is provided in order to prevent dirt or other contaminations from entering into the container. The cover typically consists of cardboard or of a plastics material.

10 In order to continuously feed welding wire to the welding machine, it is known to use two containers, namely a first container which currently provides the welding wire, and a second container which is being used as soon as the wire from the first container has been entirely consumed. The end of the welding wire of the first container is joined to the beginning of the welding wire of the second container so that a continuous supply of the welding wire is ensured. After the
15 first container is empty and the welding wire is being withdrawn from the second container, the first container is replaced by a new container, and the beginning of the welding wire of the new container is joined to the end of the welding wire from the container currently used.

20 Essential for the proper function of such system is that the welding wire does not entangle or kink, in particular when the welding wire of one container has been almost entirely consumed so that the small remaining portion of the welding wire is withdrawn from the container. With known systems, no cover is provided on the container in order to ensure proper switching from one container to the other. Using an open container however results in contamination of the welding
25 wire.

WO 02/094493 shows a system with two containers in which a runner is arranged on the welding wire. The runner is a solid body and is intended to

prevent kinks in the wire by means of its weights. However, this solution has proven to not work satisfactorily.

The object of the invention is to provide a cover for a welding wire container which prevents entanglement or kinks in the welding wire, in particular when the system is switching from one container to the other, while at the same time allowing to use a cover for closing the container.

To this end, the invention provides a cover for a welding wire container, having an upper surface provided with a slot through which the welding wire can be withdrawn from the container, and having spacing means which define an inner portion and an outer portion of the slot such that welding wire extending through the inner portion of the slot is held spaced from welding wire extending through the outer portion of the slot. The invention is based on the recognition that it is possible to combine both a cover for the container so as to prevent dirt and other contaminations from entering into the container, and a means for preventing entanglement of the wire and kinks in the wire, in particular in the phase in which the system switches from one container to the other. The invention basically consists in provision of a spacing means on a cover, the spacing means holding the two portions of the welding wire of one container spaced apart, namely the portion being fed to the welding machine and the portion extending towards the other container. The cover effectively prevents dirt and other contaminations from entering the container as the slot forms only a very small opening in the cover (less than 1 % of the overall surface).

According to a preferred embodiment of the invention, the spacing means is formed such that its spacing effect can be overcome by the welding wire. This allows the welding wire to escape from the container currently used such that the system can switch to the subsequent container, without any external interference. The pulling force acting on the welding wire when being withdrawn from the container allows to automatically make the spacing means ineffective.

The spacing means can be overcome by either at least partially detaching the spacing means from the cover, by destructing the spacing means or by deflecting the spacing means so as to allow the welding wire to escape through the slot.

5 In a simple embodiment, the spacing means can be formed by an adhesive strip. The strip is attached to the cover so as to close an intermediate portion of the slot, leaving open an inner portion and an outer portion.

10 In another embodiment, the spacing means is formed from two narrow portions of the slot. These narrow portions hold the welding wire portions extending through the cover spaced from each other while at the same time allowing the wire to pass through when switching from the currently used container to the subsequent container.

15 According to an alternative embodiment, the spacing means is formed from a plate attached to the upper surface of the cover. The plate can be attached to the upper surface of the cover on one side of the slot only, which allows the spacing means to be bent upwardly when the welding wire seeks to escape through the slot. As an alternative, the plate could be attached to the cover so as to detach therefrom under the traction force of the welding wire.

20 According to a preferred embodiment of the invention, the slot in the cover extends from an edge of the cover towards the center and beyond the center. This gives the welding wire a certain freedom of movement, contributing to the prevention of entanglement and kinks.

The invention is now described in detail by means of a preferred embodiment which is shown in the drawings. In the drawings,

25 Fig. 1 shows a side view of a system using two welding wire containers with covers according to the invention;

Fig. 2 shows a side view of the system of Fig. 1;

Fig. 3 shows in an enlarged view a container according to a first embodiment of the invention;

Fig. 4 shows a perspective view of the cover shown in Fig. 3;

Fig. 5 shows a top view of a cover according to a second embodiment of the invention; and

Fig. 6 shows a top view of a cover according to a third embodiment of the invention.

Fig. 1 shows a first welding wire container 10 and a second welding wire container 12. Both welding wire containers contain a coil 14 of welding wire 16. The end portion 18 of the welding wire contained in the first container 10 is joined by a butt welding to the beginning or front portion 20 of the welding wire coil contained in the second container 12. The welding wire 16 is withdrawn from the welding wire containers 10, 12 through a feeding system 22 which is only schematically depicted.

On top of each container 10, 12 a cover 24 (see also Figs. 3 and 4) is arranged. Each cover has an upper surface 26 which closes an upper opening of the respective container, and side walls 28 extending from the upper surface 26 and positioning the cover on the respective container.

In the center of the upper surface 26, a truncated pyramid 30 is provided. Further, a slot 32 is provided in the upper surface 26. The slot 32 extends from an edge of the cover 24 towards and beyond the center of the upper surface 26. As can be seen in Figs. 3 and 4, the slot 32 extends over the left side surface and the upper surface of the truncated pyramid 30 and over almost the entire right side surface.

A spacing means 34 is provided on the upper surface of the cover. The spacing means 34 divides the slot 32 into an inner portion 36 and an outer portion 38. The welding wire feed to the welding machine extends through the inner portion 36 of slot 32, and the end portion of the welding wire coil connected to the forward end

of the subsequent welding wire coil extends through the outer portion 38 of the slot 32.

The spacing means 34, in the preferred embodiment, is formed from a plastic plate attached to the upper surface 26 of the cover 24 on one side of the slot 32 only. This attachment is schematically shown with reference numeral 40 in Figs. 3 and 4.

During operation, the welding wire is withdrawn from the respective container through the inner portion 36 of the slot. After the welding wire stored in the respective container has been entirely used, only a small loop 42 of welding wire (please see Fig. 1) remains in the container. The spacing means 34 ensures that the welding wire portion leading to the subsequent welding wire container is held spaced apart from the portion currently withdrawn from the container. This prevents any entanglement and kinks in the welding wire. If the welding wire is continued to be withdrawn from the container, loop 42 bends spacing means 34 upwardly on the side opposite attachment 40 so that the welding wire entirely escapes from the first container. The system then automatically continues to withdraw the welding wire from the second container.

Figure 5 shows a cover in which the spacing means is formed from two separate adhesive paper labels attached to the cover spaced from each other. One of the labels holds the end portion 18 of the welding wire in the outer portion 38 of the slot 32, and a second label holds the wire portion currently withdrawn in the inner portion 36 of the slot. When the system is switching from the currently used container to the subsequently used container, the paper labels are ruptured so as to allow the welding wire to escape from the container through the slot.

Figure 6 shows a third embodiment which largely corresponds to the second embodiment. In the third embodiment, the two labels are formed from a stronger material such as plastic, leather or cardboard. In order to allow the welding wire to escape through the slot when switching from the currently used container to the

subsequently used container, the labels are provided with a preformed cut which makes it easier for the welding wire to escape from the labels.

Claims

1. A cover (24) for a welding wire container (10, 12), having an upper surface (26) provided with a slot (32) through which the welding wire (16) can be withdrawn from the container, and having spacing means (34) which define an inner portion (36) and an outer portion (38) of the slot such that welding wire extending through the inner portion of the slot is held spaced from welding wire extending through the outer portion of the slot.
5
2. The cover of claim 1, characterized in that the spacing means (34) is formed such as its spacing effect can be overcome by the welding wire.
10
3. The cover of claim 1 or claim 2, characterized in that the spacing means (34) is attached to the cover (24) so as to be at least partially detachable from the cover.
4. The cover of any of claims 1 to 3, characterized in that the spacing means is formed so as to be destructible.
15
5. The cover of any of the preceding claims, characterized in that the spacing means (24) is formed so as to be deflectable such that the welding wire is allowed to pass the spacing means when the spacing means is in a deflected condition.
6. The cover of any of the preceding claims, characterized in that the spacing means (24) is formed from an adhesive strip.
20
7. The cover of any of claims 1 to 5, characterized in that the spacing means (24) is formed from a label attached to the cover.
8. The cover of claim 6 or claim 7, characterized in that the spacing means (24) is formed from an inner label and an outer label.
- 25 9. The cover of claim 8, characterized in that the inner and outer labels each have an opening for the welding wire.

10. The cover of claim 6, characterized in that the spacing means (24) is formed from a single adhesive strip.

11. The cover of any of claims 1 to 5, characterized in that the spacing means (24) is a plate attached to the upper surface (26) of the cover (24).

5 12. The cover of claim 11, characterized in that the plate is attached to the upper surface of the cover on one side of the slot (32), only.

13. The cover of any of the preceding claims, characterized in that the spacing means (34) consists of plastics.

10 14. The cover of claim 1, characterized in that the spacing means consists of at least one narrow portion of the slot at which the edges of the slot are arranged opposite each other with a distance which is smaller than the diameter of the welding wire.

15. The cover of any of the preceding claims, characterized in that the slot (32) extends from an edge of the cover towards the center and beyond the center.

15 16. The cover of any of the preceding claims, characterized in that an elevated portion (30) is provided in the center of the cover.

17. The cover of claim 16, characterized in that the elevated portion has the shape of a truncated cone.

20 18. The cover of claim 16, characterized in that the elevated portion has the shape of a truncated pyramid (30).

19. The cover of claim 18, characterized in that the slot (32) crosses one side surface and the top surface of the truncated pyramid and extends over almost the entire opposite side surface of the truncated pyramid.

25 20. The cover of any of the preceding claims, characterized in that the slot (32) has a width of approximately 20 mm.

21. A welding wire container having a body for accommodation of a welding wire coil, and an upper opening through which welding wire can be withdrawn from the body, and having a spacing means which allows to separate a welding wire portion currently withdrawn from a welding wire portion leading to another
5 welding wire container.

22. The welding wire container of claim 21, characterized that the spacing means is provided on a cover according to any of claims 1 to 20.

23. The welding wire container of claim 21, characterized in that the spacing means is arranged inside the body closed to the opening.

1/3

Fig. 1

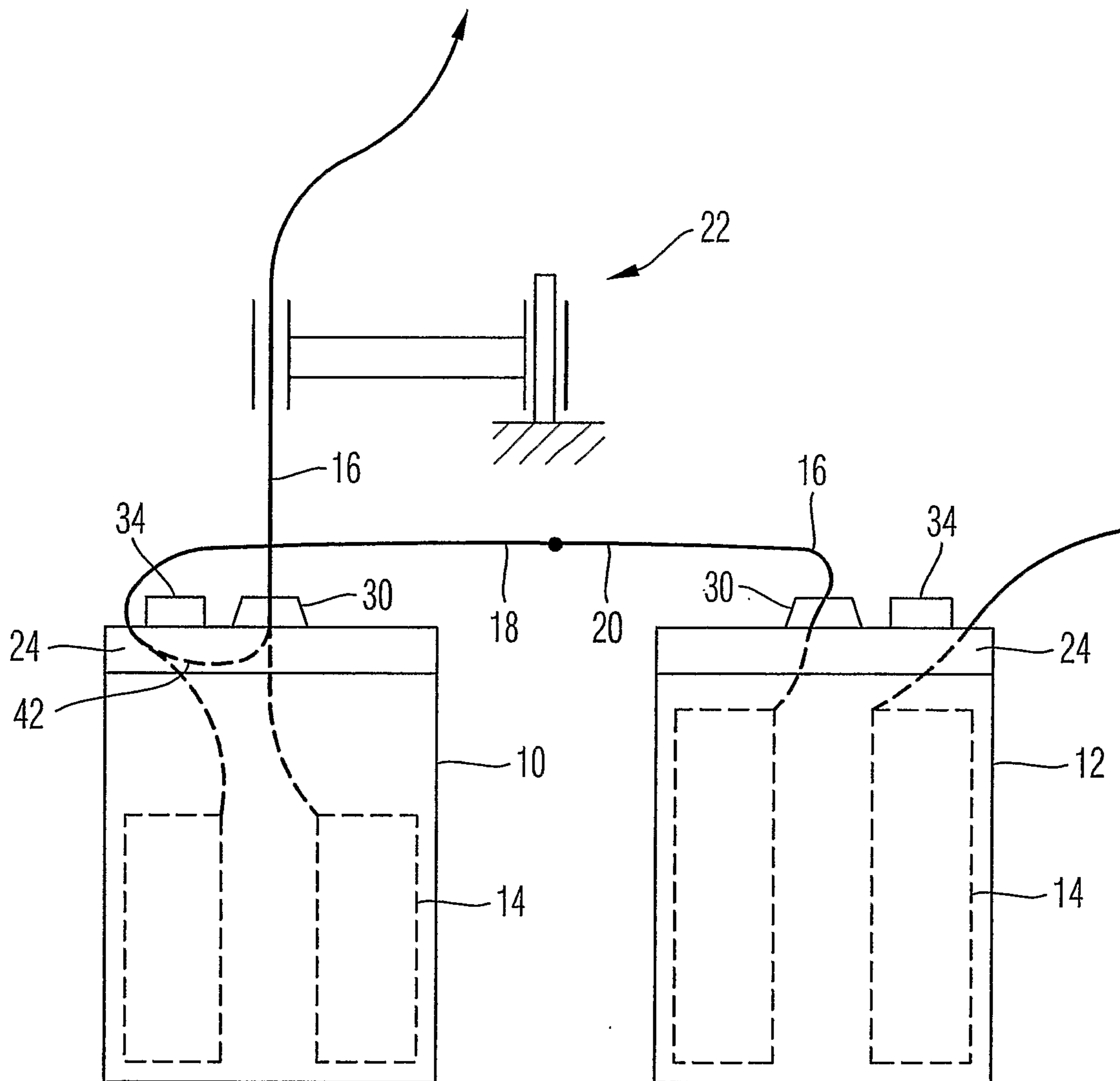

Fig. 2

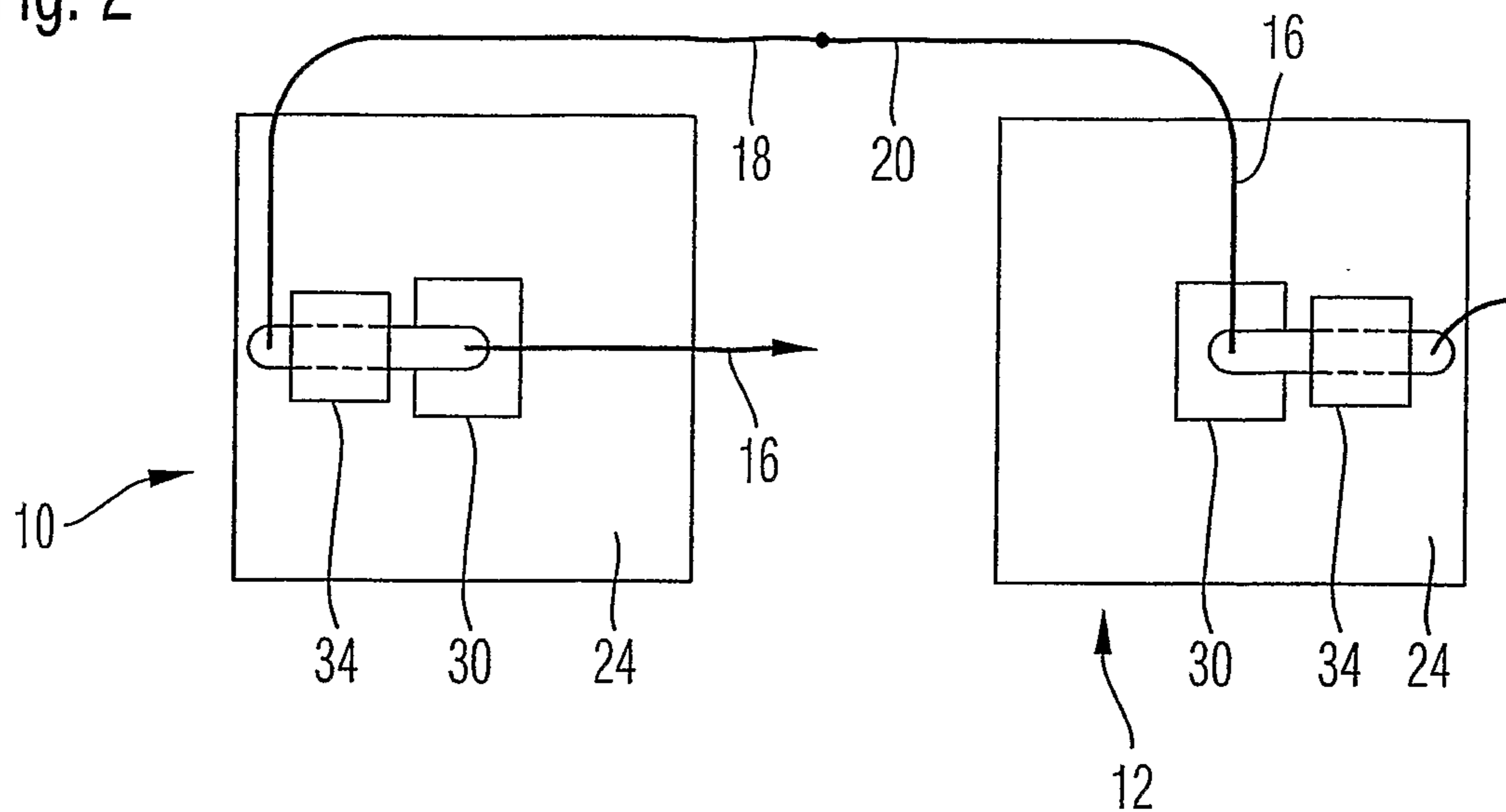

Fig. 3

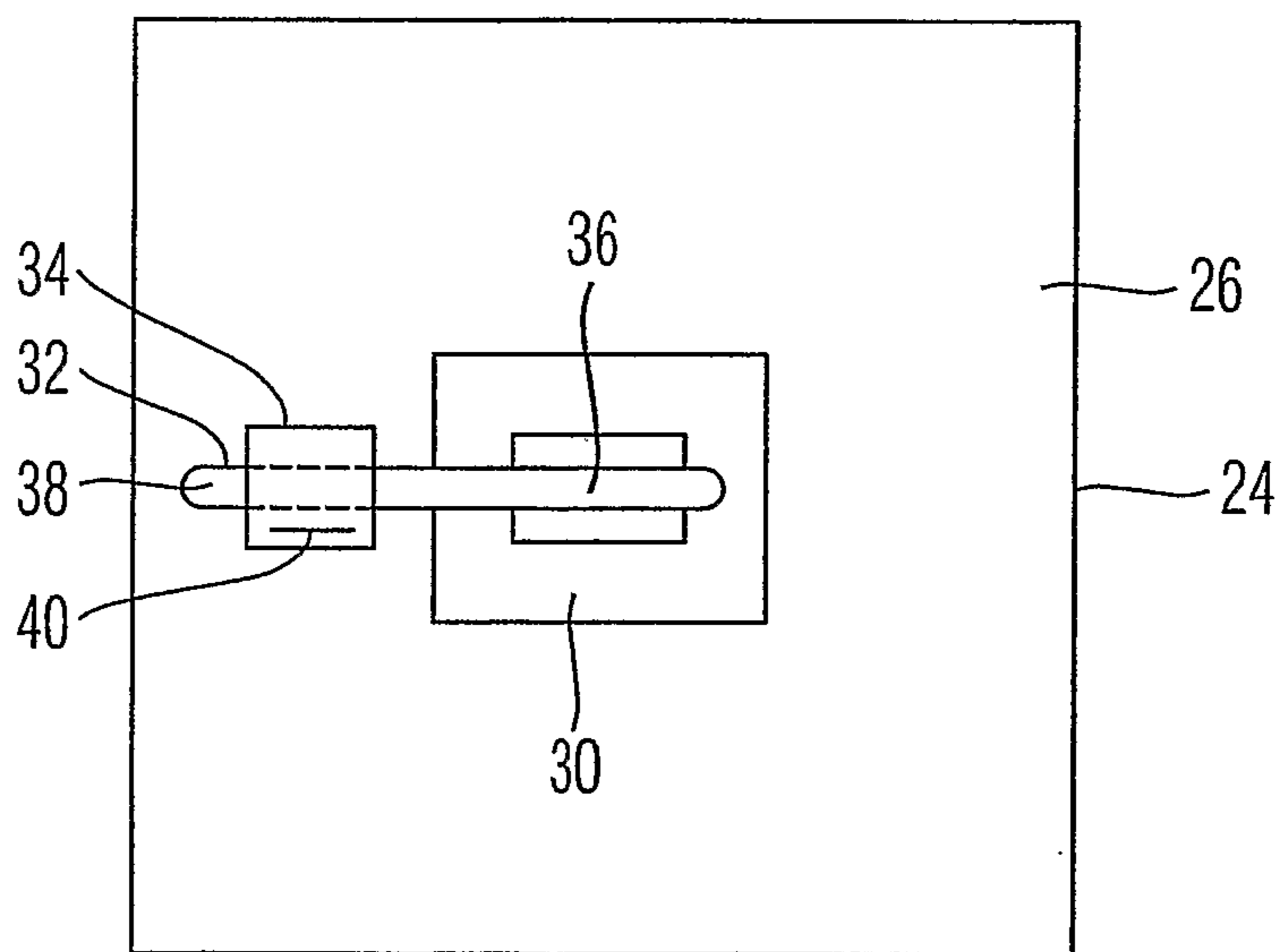
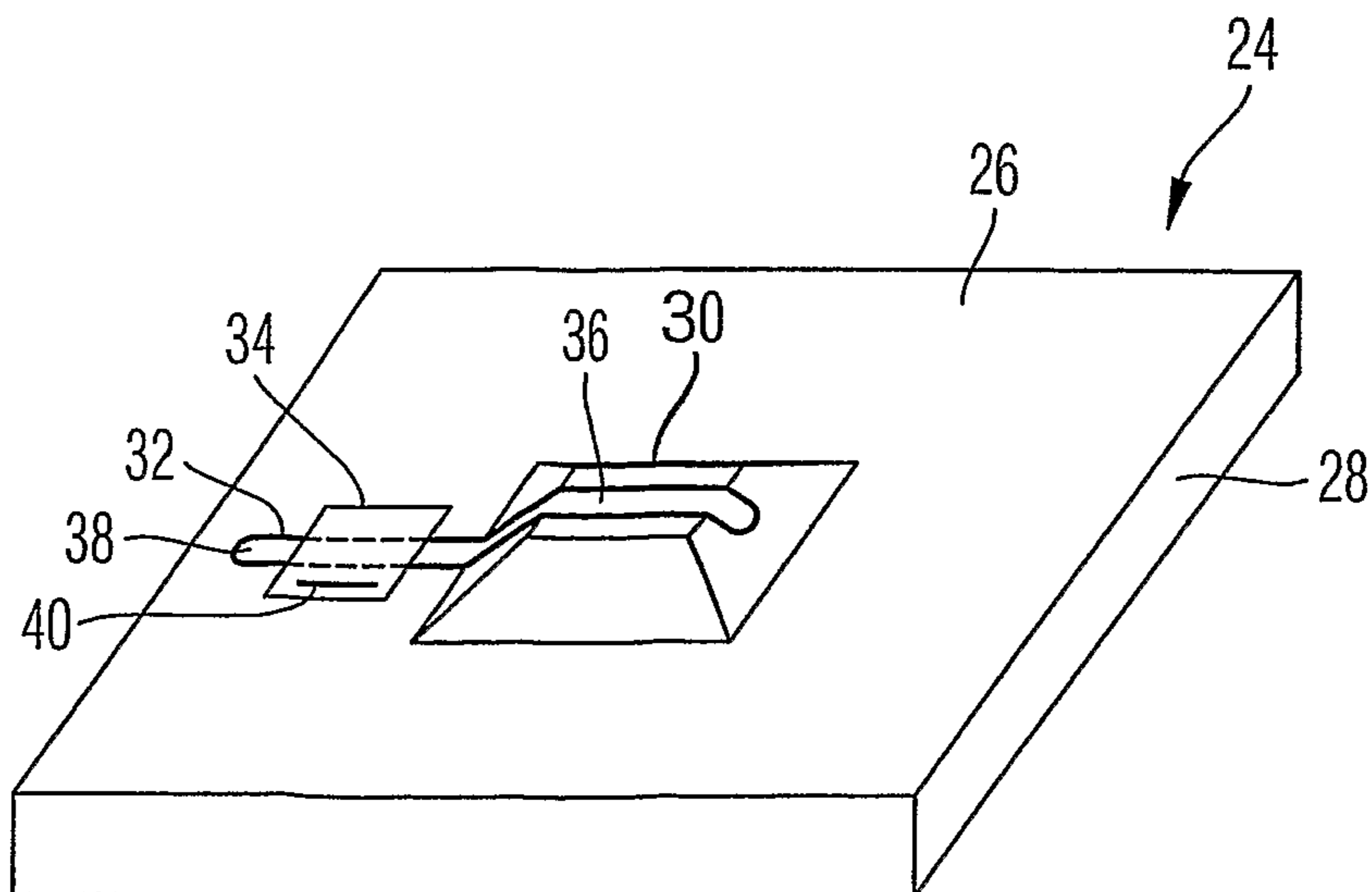

Fig. 4



3/3

Fig. 5

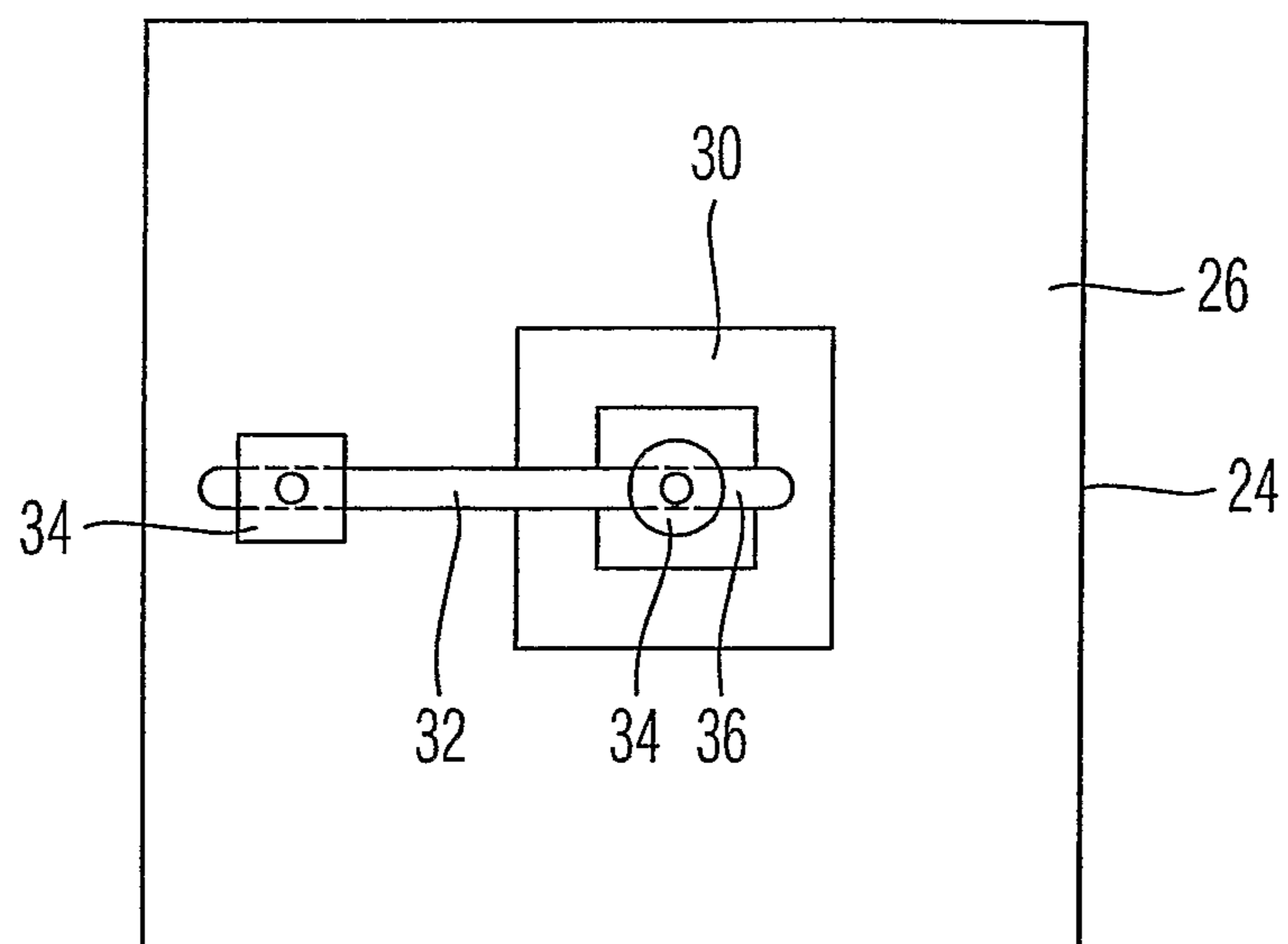

Fig. 6

