

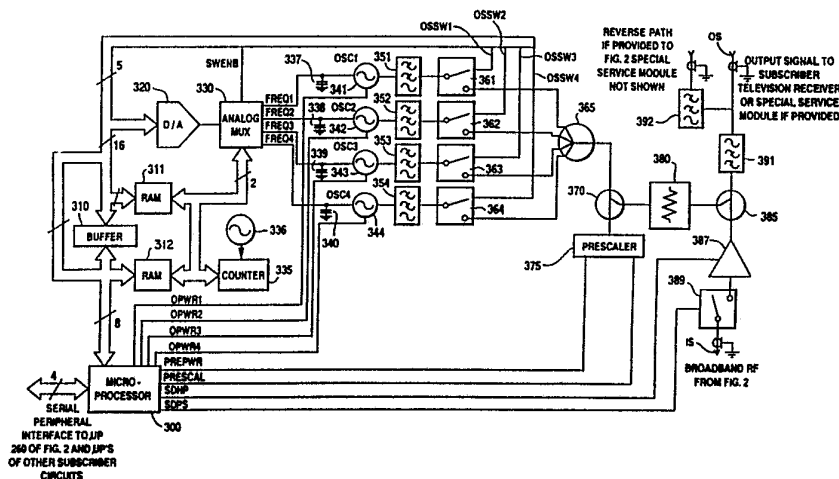

INTERNATIONAL APPLICATION PUBLISHED UNDER THE PATENT COOPERATION TREATY (PCT)

<p>(51) International Patent Classification 5 : H04N 7/167</p>	<p>A1</p>	<p>(11) International Publication Number: WO 91/08651 (43) International Publication Date: 13 June 1991 (13.06.91)</p>
<p>(21) International Application Number: PCT/US90/07185 (22) International Filing Date: 6 December 1990 (06.12.90) (30) Priority data: 446,602 6 December 1989 (06.12.89) US (71) Applicant: SCIENTIFIC-ATLANTA, INC. [US/US]; One Technology Parkway, Box 105600, Atlanta, GA 30348 (US). (72) Inventors: WEST, Lamar, E., Jr. ; Route 2, Box 377, Maysville, GA 30558 (US). BLUSIEWICZ, Philip, A. ; 3537 Tracy Drive, Duluth, GA 30136 (US). FARMER, James, O. ; 3602 Preston Court, Lilburn, GA 30247 (US).</p>		<p>(74) Agent: MARVIN, William, A.; Scientific-Atlanta, Inc., One Technology Parkway, Box 105600, Atlanta, GA 30348 (US). (81) Designated States: AT (European patent), AU, BE (European patent), CA, CH (European patent), DE (European patent), DK (European patent), ES (European patent), FR (European patent), GB (European patent), GR (European patent), IT (European patent), JP, KR, LU (European patent), NL (European patent), SE (European patent). Published <i>With international search report.</i></p>

(54) Title: OPTIMUM AMPLITUDE AND FREQUENCY OF JAMMING CARRIER IN INTERDICTION PROGRAM DENIAL SYSTEM



(57) Abstract

Off-premises cable television interdiiction apparatus comprises a microprocessor actuation and control means (300) for actuating and controlling one or more frequency agile voltage controlled oscillators (341-344). The voltage controlled oscillators (341-344) selectively jam only unauthorized premium programming transmitted in the clear from a headend to a particular subscriber. Each voltage controlled oscillator (341-344) is allocated a continuous band of frequencies consistent with the elimination of jamming signal frequency harmonics which may disturb authorized programming at a higher channel frequency. The microprocessor actuation and control means (300) provides a calibration mode and a normal mode of operation. The method of interdiiction comprises the steps of generating and storing voltage control words for operating the oscillators consistent with a headend selected jamming factor for a particular channel to be jammed and addressably transmitting and storing premium programming authorization data. An optimum frequency amplitude window for the jamming signal is disclosed.

FOR THE PURPOSES OF INFORMATION ONLY

Codes used to identify States party to the PCT on the front pages of pamphlets publishing international applications under the PCT.

AT	Austria	FI	Finland	ML	Mali
AU	Australia	FR	France	MN	Mongolia
BB	Barbados	GA	Gabon	MR	Mauritania
BE	Belgium	GB	United Kingdom	MW	Malawi
BF	Burkina Faso	GN	Guinea	NL	Netherlands
BG	Bulgaria	GR	Greece	NO	Norway
BJ	Benin	HU	Hungary	PL	Poland
BR	Brazil	IT	Italy	RO	Romania
CA	Canada	JP	Japan	SD	Sudan
CF	Central African Republic	KP	Democratic People's Republic of Korea	SE	Sweden
CG	Congo	KR	Republic of Korea	SN	Senegal
CH	Switzerland	LI	Liechtenstein	SU	Soviet Union
CI	Côte d'Ivoire	LK	Sri Lanka	TD	Chad
CM	Cameroon	LU	Luxembourg	TG	Togo
DE	Germany	MC	Monaco	US	United States of America
DK	Denmark	MG	Madagascar		
ES	Spain				

**OPTIMUM AMPLITUDE AND FREQUENCY OF JAMMING
CARRIER IN INTERDICTION PROGRAM DENIAL SYSTEM**

This application is a Continuation-in-Part of application
5 Serial Number 166,302, entitled "Off-Premises Cable Television
Channel Interdiction Method and Apparatus" filed March 10,
1988. Reference is also made to the following commonly owned
co-pending applications: "CATV Reverse Path Manifold System",
Attorney Docket No. 1263.029000; "CATV Subscriber Disconnect
10 Switch", Attorney Docket No. 1263.029011; and "Picture Carrier
Controlled Automatic Gain Control Circuit for Cable Television
Interdiction or Jamming Apparatus", Attorney Docket No.
1263.028996.

15

TECHNICAL FIELD

This invention relates to cable television systems and,
more particularly, to a method and apparatus for applying
remotely controlled and remotely applied interdiction or
20 jamming signals to prevent reception of unauthorized
television channels.

BACKGROUND ART

25 At a headend of a cable television system, a scrambler
is normally provided to encode premium television channels.
The applied scrambling precludes reception by an unauthorized
converter/decoder at a connected premises. Data representing
channels or tiers of programming are addressably transmitted
30 to a particular converter/decoder and stored in an
authorization memory. As a result of the addressed
transmission, a subsequently transmitted program is authorized
in that the decoder portion of the converter/decoder will be
selectively enabled to decode the scrambled premium channel
35 or program.

Several varieties of scrambling techniques are applied
today. Each manufacturer has its own scheme which may be

incompatible with others. Nevertheless, most popular scrambling systems today are based on sync suppression, in which the sync information is hidden from the television receiver's sync separator, usually by moving it to a level 5 occupied by picture information (moving the sync tip to an equivalent picture level of 40 IRE units is common). Some systems modulate the video carrier with a sine wave phased to suppress the horizontal blanking interval. Most systems today switch to the suppressed level at the beginning of the 10 blanking interval and switch out at the end. Most, though not all, suppress the vertical blanking interval. Some systems dynamically invert the video, either on a line-by-line or field-by-field basis. This must be done carefully to avoid artifacts caused by inverting and reinverting around different 15 levels, and by differential gain and phase of the system. Synchronization is restored either by the provision of synchronous amplitude modulated pulses on the sound carrier, by digital information placed in the vertical interval or by phase modulation on the video carrier.

20 The provision of one scrambler per premium channel at the headend and the inclusion of a descrambler in each converter/decoder at the premises of the television receiver is particularly expensive. Furthermore, by providing the converter/decoder on premises has turned out to be a great 25 temptation to service pirates who imaginatively seek ways to receive premium channels. As a result, cable television equipment manufacturers have entered into a veritable war with such pirates resulting in complicated service authorization protocols in some instances involving multiple layers of 30 encryption by both in-band and out-of-band data transmission further increasing the costs of the converter/decoder.

Furthermore, all scrambling systems have artifacts in the horizontal blanking interval in the form of steps on the front and back porches. Normally these are not a problem, but 35 if a television receiver does not have adequate overscan, then the steps can show up as light bars on one or both sides of the picture. Further, if a television receiver uses back

porch sampling for automatic gain control and/or black level restoration, and the sampling period extends into the time of the descrambling step, the television will show the wrong black level and may show flicker in the picture. In systems
5 in which pulse trains are applied to the sound carrier, a buzz carried by harmonics of a 59.94 Hz signal can be noticed in some television receivers.

Consequently, the cable industry has resorted to look for new technology and to take a second look at technology
10 developed in the early stages of development of cable television such as the application of negative and positive traps and more recent techniques such as interdiction.

Negative trap technology is viewed by many manufacturers as a viable alternative to sync suppression
15 scrambling methods. A negative trap is basically a narrow band reject filter. Traps are located at the drop to a subscriber's dwelling and attenuate a significant portion of a premium television channel rendering that channel unusable by the subscriber.

20 In the conventional embodiment, negative traps are made using L-C filter techniques. The result is a notch with finite quality, Q , and finite shape factor. In the case of a single channel negative trap, the center of the notch is usually located at the video carrier frequency of the channel
25 to be removed. This technique, sometimes called a static negative trap, requires attenuation at the video carrier of at least 60 dB to be effective.

Negative trap systems have several advantages that make them attractive for cable television applications. One
30 primary advantage is the ability to deliver a broadband cable television spectrum to the subscriber's converter/decoder. Conventional sync suppression systems utilize descrambling set-top converter/decoders which deliver inherently narrowband signals. Negative traps are usually mounted outside the
35 subscriber's home (typically at the tap) and thereby minimize the exposure associated with placing hardware inside the subscriber's dwelling. Finally, some cable television

operators view the negative trap as a more secure means of subscriber control than is sync suppression, as picture reconstruction is viewed as substantially more difficult.

However, the negative trap system requires hardware in 5 locations where no revenue is generated for the cable television system. Moreover, negative traps have several severe practical limitations. L-C band reject filters have Q and shape factor limitations. Quality factors Q for L-C filters are typically limited to less than 30. This means 10 that for a negative trap located at channel 8 (video carrier at 181.25 MHz) the 3 dB bandwidth of a negative trap is typically 6 MHz (or the bandwidth of a baseband television channel). This trap would result in significant deterioration of the lower adjacent channel. Then the television receiver 15 tuned to the lower adjacent channel, rather than having to contend with a 15 dB picture-to-sound ratio, may have to contend with a sound carrier reduced an additional 6 dB or so. Frequency stability as a function of time and temperature is also a significant concern. Many cable television system 20 operators have instituted a regular negative trap change-out program based on the assumption that after a certain period of time and temperature cycling, frequency drift will render negative traps useless.

Cascadability is another significant concern. Finite 25 return loss and non-zero insertion loss limit the number of single channel negative traps which can be cascaded. As the number of services to be secured increases, the negative trap decreases in appeal. Moreover, a change in channel line-up requires a significant investment in hardware and manpower in 30 this scenario.

Recently, a new type of negative trap has been introduced. The dynamic negative trap consists of a notch filter that is designed to be modulated with respect to frequency. The notch is centered about the video carrier but 35 is deviated slightly from side to side. The television channel is rendered unusable by the introduction of unwanted amplitude and phase modulation on the video carrier. This

technique requires a notch depth significantly less than that of static negative traps (typically 40 dB). Additionally, the intentionally introduced frequency modulation reduces somewhat the requirement for frequency stability.

5 The dynamic negative trap, however, has several disadvantages. A power source is required in order to accomplish the frequency modulation. More significant is the parasitic modulation that this technique produces on the adjacent television channels.

10 Positive trap systems also utilize a narrow band--rejector notch filter. However, unlike negative trap systems which are used to attenuate or trap a premium channel transmission, the notch filter is used to restore the premium television channel. In this scenario, an interfering signal
15 is placed inside the premium television channel at the cable television headend. This interfering signal is then removed at the subscriber's dwelling by use of the notch filter. Ideally this notch filter removes only the interference without removing a significant amount of television
20 information.

 The positive trap technique is seen as having several advantages by the cable television system operator. It is considered advantageous to have the interference present in the secured channels on the cable television distribution
25 plant (unlike the negative trap system in which the channels to be secured are "in the clear" on the distribution plant). It is very attractive from a financial standpoint to require subscriber hardware only at those locations where a subscriber wishes to receive a secure service. Thus, any capital
30 investment is associated with a point of revenue generation.

 The conventional embodiment of the positive trap system utilizes L-C notch filters to remove the interfering signal. These L-C notch filters suffer from the same limitations as do L-C negative traps discussed above.
35 Consequently, L-C based positive traps are limited to the lower end of the cable television spectrum. Quality Q and shape factors have also restricted the number of locations for

the interfering signal within the television channel.

The location for the interfering signal in the conventional embodiment of the positive trap system is midway between the video carrier and sound carrier. The energy density (and hence information density) in this area of the spectrum is relatively low. One reason this location was chosen was that it minimized the impact of any television information removed along with the interfering signal by the notch filter, and thereby improved the quality of the recovered television signal. It would be expected that the jamming carrier would normally have minimal effect on the adjacent channel television picture unless a television has unusually poor rejection 2.25 MHz above the video carrier. The jammer does add another carrier which the tuner will have to contend with, which might cause some degradation in a marginally overloaded case.

Despite this location, the quality Q and shape factor limitations of conventional L-C positive traps do remove a significant amount of useful television information. The result is a noticeable "softening" of the television picture as a result of attenuation of high frequency information. Predistortion at the headend can improve this performance but falls far short of being able to correct it completely. This location for the interfering signal also facilitates the job of the video pirate. This pirate can easily tolerate a degraded signal and hence can recover a usable picture using techniques easily available (such as the classic twin lead quarter wave stub with an aluminum foil slider for fine tuning). Also, positive trap systems require a higher per premium channel cost than a negative trap system.

A relatively recent technique for premium channel control is the interdiction system, so-called because of the introduction of an interfering signal at the subscriber's location. Most embodiments consist of a pole-mounted enclosure designed to serve at least one and up to four or more subscribers. This enclosure contains at least one microprocessor controlled oscillator and switch control

electronics to secure several television channels. Control is accomplished by injecting an interfering or jamming signal into unauthorized channels from this pole-mounted enclosure.

For efficiency's sake, it is known to utilize one
5 oscillator to jam several premium television channels. This technique not only reduces the amount of hardware required, but also maximizes the system flexibility. The oscillator output jamming signal frequency is sequentially moved from channel to channel. Consequently, the oscillator is frequency
10 agile and hops from jamming one premium channel frequency to the next.

One such system is known from U.S. 4,450,481 in which a single frequency agile oscillator provides a hopping gain-controlled jamming signal output to four high frequency
15 electronic switches. Each switch is associated with one subscriber drop. Under microprocessor control and depending on which subscribers are authorized to receive transmitted premium programming, the microprocessor selectively gates the jamming signal output of the single oscillator via the
20 switches into the path of the incoming broadband television signal to each subscriber. Consequently, an unauthorized subscriber, upon tuning to a premium channel, will receive the premium channel on which a jamming signal at approximately the same frequency has been superimposed.

25 In the known system, it is indicated that sixteen channels may be jammed by a single voltage controlled frequency agile oscillator. With respect to one premium channel, this translates to a situation in which the jamming signal can only be present one sixteenth of the time or an
30 approximately 6% jamming interval. The rate of hopping is also indicated at 100 bursts per second of jamming signal or a 100 hertz hopping rate. A single oscillator may be used if it provides an acceptable amount of jamming.

Cable television channels and, of course, premium
35 service may extend over a wide range of frequencies, for example, from 100 to 350 megahertz. In the known embodiment, the single oscillator provided must be frequency agile over

a wide range. It has been previously disclosed in U.S. Patent 4,450,481, e.g., that the jamming signal output of the single oscillator must be within a range of 100-500 KHZ above or below the video carrier frequency. Consequently, a
5 synthesizer having an internal reference is provided to assure the reasonable accuracy of the jamming signal output of the oscillator to the tolerable 100-500 KHZ band above or below the video carrier. However, it has been determined that this range does not provide the desired jamming effect on all TV
10 sets.

According to the present invention, it has been found that if the jamming signal is more than about 200 KHZ above the video carrier, jamming is inadequate on some TV sets which is obviously undesirable. When the frequency of the jamming
15 carrier is more than 100 KHZ below the video carrier, reduced jamming and potential interference with the lower adjacent channel may occur. This too is undesirable.

It has also been previously disclosed in U.S. Patent 4,450,481 that the jamming signal amplitude should exceed the
20 amplitude of the video carrier by 5 to 20dB.

However, it has been determined that this range of amplitudes is not desirable. If the jamming signal level exceeds the video carrier by about 6dB or more, the phenomena of adjacent channel interference may be observed on some TV
25 sets, when such sets are tuned to the lower adjacent channel to the one jammed. Moreover, when the amplitude of the jamming carrier is too great, e.g., more than 6 dB above the video carrier, the noise rejection circuit of some TV sets has been found to eliminate the jamming signal thereby countering
30 the jamming effect.

In order to overcome these undesirable effects, it is preferable that the jamming frequency be controlled so as to place the interference as close as possible to the video carrier. It is also preferable to limit the peak amplitude
35 of the interfering signal so as not to significantly exceed the video peak envelope power in order to ensure that there are no residual artifacts on adjacent channels. However, in

the known system, adjacent channel artifacts may also be created since the jamming signal is intentionally placed well below the video carrier and consequently proximate to an adjacent channel. Also, the rate of frequency hopping is limited in the known embodiment as a result of its application of conventional frequency control techniques during the hopping process.

The known interdiction system has proven to be particularly susceptible to inadequate jamming and/or adjacent channel artifacts from the above-described amplitude and frequency selections which can dissatisfy subscribers.

DISCLOSURE OF THE INVENTION

Many of the above-stated problems and related problems of the prior art have been solved with the principles behind the present invention, an off-premises television channel interdiction method and apparatus capable of remotely controlled jamming depth and frequency at reduced power. After considerable investigation into the known art and through experimentation, it has been determined that an optimum placement of a jamming signal is within the range extending from approximately about 100 KHz below the video carrier to about 200 KHz above the video carrier, since a jamming signal placement much below the 100 KHz below the video carrier can create artifacts on the next lower adjacent channel, and a placement more than 200 KHz above the video carrier can cause, inadequate jamming to occur on certain TV sets.

Also, from the head end, the jamming carrier may be precisely established at a frequency resolution of 50 KHz as a digitally step-wise selectable frequency within this range. A ten bit voltage control word is applied by way of a digital to analog converter to a voltage controlled oscillator to control the frequency of the jamming signal within this frequency range.

Furthermore, to insure the accuracy of the frequency

of the jamming signal and to limit jamming signal frequency harmonic interference, a plurality of oscillators may be provided, each operating within a particular narrow band of the cable television spectrum. The sum of all such narrow
5 bands shall be equivalent to the entire spectrum over which jamming is desired, recognizing that the cable television spectrum to be jammed may itself be discontinuous or that some overlap in bands may be desired. In a preferred embodiment, four separate oscillators may be provided whose outputs are
10 separately filtered to eliminate the appearance of harmonics of the jamming signal output which can interfere with television reception on other channels higher in the spectrum. Each oscillator may be intentionally limited to jamming a maximum of four channels within its band resulting in
15 approximately a factor of four improvement in jamming interval over the prior art. Furthermore, each plurality of oscillators is provided on a per subscriber or per drop basis.

Also, in accordance with the principles behind the present invention, the jamming signal power is limited within
20 the range of -2.5 dB and +6.5 dB or +2dB nominal of the video carrier power level. Consequently, there is less chance of adjacent channel interference than in the known prior art system.

Further, it has been determined that jamming depth,
25 the subjective perception of one viewing a scrambled television channel on a number of different television receivers, is improved by improving the frequency hopping rate to approximately four kilohertz, a factor of twenty increase in rate over the known system, all other parameters being
30 equal such as amplitude and frequency of the jamming signal. As will be discussed herein, the present embodiment is capable of achieving frequency hopping rates of this magnitude because it is not limited by conventional frequency locking techniques.

35 The microprocessor of the present apparatus may also control the provision of power to one or more oscillators. If the subscriber is authorized to receive all premium

channels within the band secured by a given oscillator, that oscillator may be powered down for the duration. Furthermore, no residual jamming signal output power will pass through an intentionally open switch during a powered up condition as
5 might occur in the prior art interdiction system.

Common circuitry is shared by a plurality of subscribers, for example, up to four or more, and is housed in a pole-mounted, strand-mounted or pedestal housing. The common circuitry comprises automatic gain control circuitry
10 for regulating the level of video carrier. The common circuitry also comprises a data receiver, a data decoder and a microprocessor which may be individually addressed. The common circuitry separately decodes for each addressed and in service subscriber module any commands and data transmitted
15 from the headend. The microprocessor of the common circuitry communicates with the microprocessor of the subscriber module any decoded data related to the particular subscriber served by that subscriber module. The decoded data, for example, indicates individually addressed channel or program
20 authorization data or globally transmitted channel frequency and jamming depth data received from the headend for storage in microprocessor memory.

During a normal mode of operation, the microprocessor of the subscriber module actuates or powers up each required
25 oscillator and transmits frequency data toward all required oscillators for jamming any and all unauthorized channels at a jam factor selected for a particular premium channel. In particular, a sixty-four position memory may be reserved for storing ten bit voltage control words. An algorithm of the
30 subscriber module microprocessor loads the voltage control word memory depending on the level of service chosen by the subscriber. In one extreme where a particular subscriber is authorized to receive all premium channels but one, three of the oscillators may be powered down and the remaining
35 oscillator is capable of continuously jamming the one unauthorized channel resulting in a 100% jamming interval.

If a particular subscriber at a given point in time

has subscribed to none of the sixteen channels offered, and if a plurality of oscillators is used, the oscillators are sequentially triggered and sixty-four voltage control words are provided in a pseudo-random sequence to the four
5 oscillators. The application of such a pseudo-random sequence discourages pirating.

Jam factor as defined herein is a parameter selectable and globally transmitted by the headend to equate to the relative degree of jamming to be applied to different premium
10 channels. For example, it may be appropriate to jam highly restricted programming at a higher jam factor. In accordance with the present invention, a total of sixteen voltage control words may be allocated to one premium channel. Consequently, these sixteen control words are analogous to jamming time slot
15 intervals which can be allocated by the headend to improve jamming depth. For example, if three premium programs are provided by the headend over channels within the allocated band of one oscillator at a particular point in time, these sixteen time slots or their responsive jam factors may be
20 allocated at eight, four and four respectively (totalling sixteen) to effectuate, for the least jammed channel and allowing a five percent overlap, a minimum 20% jamming interval. As already indicated, if the subscriber subscribes to all of these three channels, the microprocessor algorithm
25 will power down or deactuate the oscillator entirely or increase the jamming interval proportionate to the degree of premium service subscribed to and the assigned jamming factors.

Periodically and at power up, the present apparatus
30 enters a calibration mode of operation, for example, at approximately thirty minute intervals. From the front end, premium channel frequency data is globally transmitted for storage in memory of the microprocessor of the common circuitry. The common circuitry microprocessor calculates in
35 turn calculates a divide by factor for a programmable prescaler of the subscriber module and an expected time between frequency counts and forwards these calculations to

the microprocessor of the subscriber module.

The programmable prescaler or frequency divider is provided in a feedback path from the plural oscillators to the microprocessor of the subscriber module. During the calibration mode, only one oscillator is powered at a time. The transmitted and stored frequency data is translated into a best guess voltage control word. As a result, the jamming signal frequency of the only powered-up oscillator is fed back through the prescaler which divides down the high frequency output for counting by the microprocessor. The microprocessor calculates a count in accordance with the known time interval between received outputs of the prescaler. The count is then compared with the expected count and the voltage control word, a particular control word is precisely established in voltage control word memory. In sequence, all sixteen control words for each provided oscillator or all sixty-four words are precisely established, the entire procedure requiring only a fraction of a second. Consequently, no meaningful intelligence can be obtained during the calibration mode if a subscriber coincidentally attempts to view an unauthorized premium channel. Thus, the calibration mode in combination with the provision of plural narrow band oscillators assures jamming signal frequency control.

As a consequence of the calibration mode of operation and the structure of the present apparatus, the jamming carrier is optimally positioned anywhere within the range from 100KHz below the video carrier to 200KHz above the video carrier. During the thirty minute interval in times of temperature variations, there is an opportunity for frequency drift of a given jamming signal frequency. However, the drift, if existent, is actually desirable in the sense that such a drift will thwart any would-be pirates attempting to trap the jamming signal with a notch filter. As alluded to before, the jamming signal frequencies may also be intentionally varied within the above range by varying the voltage control words for jamming a given premium channel. Furthermore, they may be applied in a pseudo-random sequence.

Consequently, a would-be pirate would have to follow the same pseudo-random sequence and sequentially actuate a plurality of notch filters, all at the same frequencies as are represented by the associated voltage control words as well
5 as anticipate the natural frequency drift previously alluded to in order to pirate the premium television signal.

Importantly also, the application of a calibration mode of operation, as distinct from a normal mode of operation, permits the present apparatus to achieve much
10 higher frequency hopping rates than the known system during the normal mode of operation. Because there is no requirement for the application of slow convention frequency locking techniques during the normal mode of operation, a desirable four kilohertz hopping rate is achievable.

15 These and other advantages of the present method and apparatus for providing remotely and addressed controlled interdiction will now be explained with reference to the drawings and the following detailed description of one embodiment.

20

BRIEF DESCRIPTION OF THE DRAWINGS

Figure 1 is an overall system block diagram showing the inherent compatibility of the present interdiction
25 apparatus with existent cable television systems comprising premium channel scramblers, addressable data transmitters, and subscriber converter/decoders.

Figure 2 is a block schematic diagram of an addressable common control circuit for the plurality of
30 provided subscriber modules in accordance with the present invention comprising a broadband signal tap, a microprocessor, a data receiver and decoder and an automatic gain control circuit.

Figure 3 is a block schematic diagram of one
35 subscriber module comprising a microcompressor for selectively actuating and controlling the output frequency provided by each of four voltage controlled oscillators such that during

a normal mode of operation sixteen premium channels may be jammed at a minimum twenty percent jamming interval and, during a calibration mode, a feedback path is provided to the microprocessor through a programmable prescaler to precisely
5 establish jamming signal frequencies.

Figure 4 is a frequency plan for allocating the broadband cable television spectrum among four separate bands, each of which bands comprising a plurality of channels greater than or equal to four but, of which plurality, only four
10 channels may be jammed at a 20% jamming interval.

Figure 5 is a detailed block schematic diagram of one embodiment of a feedback loop structure for implementing the calibration mode of operation of the present invention.

Figure 6 is a block diagram of the voltage control
15 word memory in connection with the sequential provision of oscillator jamming frequency signal outputs during a normal mode of operation.

Figure 7 is a timing diagram for the embodiment of Figure 3 during a normal mode of operation in which each
20 interdiction control signal is particularly depicted.

Figure 8 is a graphical illustration of the optimum amplitude-frequency window of the jamming carrier with respect to the video carrier.

25

MODE(S FOR CARRYING OUT THE INVENTION

Referring more particularly to Fig. 1, there is shown a general block diagram of a cable television system employing the principles of the present invention. By cable television
30 system is intended all systems involving the transmission of television signals over cable toward remote locations. For example, a cable television system may comprise a community antenna television distribution system, a private cable distribution network, either industrial or education, or other
35 forms of such systems. Each remote location of a television receiver may comprise the location of a particular subscriber to a subscription television service, plural subscribers,

single subscribers having plural television receivers or private locations in a private cable distribution network. Consequently, the term subscriber, when used in this application and the claims, refers to either a private subscriber or a commercial user of the cable television system. Headend 100 as used in the present application and claims is defined as the connecting point to a serving cable 110 for distributing television channels to subscriber locations. For reference purposes, an Electronic Industries Association (E.I.A.) standard cable television frequency allocation scheme is employed and referred to herein; however, by means of the following disclosure of the present invention, one may apply the principles to other known standards or non-standard frequency allocations. Furthermore, a National Television Subcommittee (N.T.S.C.) standard composite television signal amplitude modulated onto a radio frequency carrier is generally considered in the following description; however, the principles of the present invention apply equally to other standard and non-standard baseband television signal formats.

Headend 100 comprises a source of television programming 101. Television program source 101 may be a satellite television receiver output, a program produced by a television studio, program material received over a microwave or broadcast television link, a cable television link output, or any other source of television programming consistent with the present invention. The program source material need not be limited to conventional television but may comprise teletext, videotex, program audio, utility data, or other forms of communication to be delivered to a remote location over the serving cable 110.

Program material provided by source 101 may be premium or otherwise restricted or desirably secured from receipt at unauthorized receiver locations. To this end, each channel or program to be secured is generally scrambled by scrambler 102 provided at headend 100. By the use of the term premium channel or premium programming in the present application and claims is intended a channel or program which is desired to

be secured from unauthorized receipt either because of its premium or restricted status.

Normally, all premium programming is known cable television systems is scrambled. However, in accordance with
5 the present invention, premium programming is transmitted in the clear, and interdiction is applied at off-premises interdiction apparatus 130 to jam reception of unauthorized premium programming.

Consequently, during a transition period in which
10 headend 100 provides scrambled television programming as well as premium programming in the clear, a scrambler 102 will be provided so long as converter/decoders 150 are provided to subscribers for unscrambling scrambled program transmission. In certain instances, converter/decoders 150 may be entirely
15 replaced by interdiction apparatus 130 of the present invention.

Also, at the headend, there is normally an addressable data transmitter 103 for transmitting global commands and data to all subscribers or addressed communications for reception
20 by a unique subscriber. Such data transmission may be conducted over a separate data carrier from the cable television spectrum, for example, at 108.2 megahertz. It may also be transmitted over an unused default channel in the television spectrum. Global commands generally take the form
25 of operation code and data while addressed communications further comprise the unique address of a particular subscriber.

In another alternative embodiment, such communications may take the form of in band signals sent with a television channel superimposed upon an audio carrier during, for
30 example, the vertical interval of the video signal. Such data communications further complicate data reception at intervention apparatus 130 in accordance with the present invention and are desirably eliminated. However, in band signaling is sometimes required for the operation of certain
35 converter/decoders 150 known in the art.

Consequently, headend 100, cable television distribution cable 100, and converter/decoders 150 and

television receivers 170 at a typical subscriber premises 181
comprise a typical known cable television system. Channel
program or authorization data is transmitted via an
addressable data transmitter 103 over a cable 110. At a pole
5 120 or from a pedestal 140 at underground cable locations, the
serving signal is dropped via drop 115 to a subscriber
location. Drop 115 is connected to a conventional
converter/decoder 150 which served several functions.
Responsive to an addressed communication from headend
10 transmitter 103, channel or program authorization data is
updated in an authorization memory if the address associated
with the addressed communication matches a unique address of
the subscriber decoder 150. For example, the subscriber
address may comprise a plurality of bits over and above the
15 actual number of subscribers in a system, additional bits
insuring the security of the address. The premium channel or
program is then stored in the authorization memory of the
converter/decoder 150. Television programming is normally
converted to an otherwise unused channel such as channel 3 or
20 4 of the television spectrum by a converter portion of
converter/decoder 150. Its premium status is checked against
the data stored in authorization memory. If the programming
is authorized, the decoder portion of the converter/decoder
is enabled to decode authorized scrambled premium programming.

25 The provided television receiver may be a conventional
television receiver 170 or may be a so-called cable ready
television receiver 171. Because of the advent of cable ready
television receivers 171, there is no longer a requirement at
a subscriber premises 181 for the converter portion of the
30 converter/decoder 150 as a converter is built into such
television receivers.

In accordance with a cable television system provided
with interdiction apparatus 130 of the present invention, a
housing is mounted on a strand supporting cable 110, to a pole
35 120, or provided via a pedestal 140. Inside the housing is
common control circuitry for tapping into the broadband
television and data transmission spectrum. Referring to the

first pole 120 from the left of Fig. 1, there is shown a strand-mounted apparatus serving two drops 115 to subscribers. Altogether, four or more subscribers and up to four or more drops 115 may be served by interdiction apparatus 130. (Four is a practical number but the invention is equally applicable to equipment serving a much greater number of subscribers such as might be found in multiple dwelling unit installations.) Besides the common control circuitry, four plug-in subscriber modules may be provided for one housing. Also, if desired, additional services may be provide via other plug-in units of the housing such as impulse pay-per-view, subscriber polling involving two way data communication, meter reading, energy management or other services.

Desirably, all equipment 161 may be removed from the subscriber premises 182. However, for the provision of additional services, some on-premises equipment may be unavoidable. For purposes of this description, premises 182 will be assumed to include at least one non-cable ready conventional television receiver 170. Consequently, subscriber equipment 161 must be at least comprise a tunable converter for converting a received cable television channel to an unused channel such as channel 3 or 4 for reception on conventional television receiver 170.

Power for interdiction apparatus 130 may be provided over the cable from the headend 100 or be provided via the subscriber drop 115 or by a combination of such means. Forseeably, power may be even provided by rechargeable means such as solar cells or other external or replaceable internal sources such as batteries. Consequently, subscriber equipment 161 may also comprise a source of power for interdiction apparatus 130.

Interdiction apparatus 130 may be secured in a tamper-resistant housing or otherwise secured such as in a locked equipment closet of an apartment complex. If located in a place exposed to the elements, the housing should be watertight. Also, the housing should be designed to preclude radio frequency leakage.

At premises 183, the subscriber is presumed to have a cable-ready television receiver 171. Consequently, subscriber unit 162 may be entirely eliminated or comprise simply a power feed to interdiction apparatus 130.

5 Premises 184 pictorially represents a subscriber location served by an underground cable 110 via a pedestal 140. In accordance with the present invention, pedestal 140 may comprise an off-premises housing for interdiction apparatus 130. Other pedestals 140 are generally used in
10 buried cable installations as housings for cable distribution amplifier and other equipment. Subscriber equipment 162 may comprise a converter, an additional service device and a power unit as described in reference to subscriber equipment 162.

Interdiction apparatus 130 is uniquely addressable by
15 headend 100 just as is converter/decoder 150. If two bits of a plural bit unique subscriber addresses are associated with uniquely identifying one plug-in slot for one of four subscriber modules, common control circuitry may be uniquely addressed with remaining address data not used to secure the
20 data communication. Just as premium programming is transmitted in the clear and since no data communication is necessarily required with a subscriber premises, a subscriber address need not be transmitted in a secure form in accordance with the principles of the present invention. Nevertheless,
25 address security may be desirable so long as converter/decoders 150 or other unique address requisite equipment is provided at a premises.

Interdiction apparatus 130 comprises addressable common control circuitry and up to four or more plug-in
30 subscriber modules. Upon receipt of subscriber specific premium program or channel authorization data, the data is stored at interdiction apparatus 130. Interdiction apparatus 130 further comprises automatic gain control circuitry of the common control circuitry. Channel interdiction circuitry
35 associated with each subscriber module jams unauthorized premium programming dropped via a particular drop 115 to a particular subscriber. Consequently, interdiction apparatus

130 is reasonably compatible with addressable nationalization data transmission known in the art. No scrambling of premium channels (and no resulting artifacts) is necessary or desirable. Further, no additional forms of service security
5 are necessary such as channel encryption, in-band channel or tier verification or other security measures. The would-be service pirate must attempt to remove a particular psuedo-randomly timed jamming signal placed at a varying frequency or seek to tamper with the off-premises apparatus 130 to
10 derive a signal from shielded and bonded cable 110 which should likewise be maintained secure from radio frequency leakage.

The common control circuitry of interdiction apparatus 130 will now be described by means of the block diagram Fig.
15 2 for serving four subscriber modules in accordance with the block diagram Fig. 3. Referring particularly to Fig. 2, a feeder cable 110 is shown entering interdiction apparatus 130 at FEEDER IN and leaving at FEEDER OUT. Power PWR may be provided via the feeder cable by means of a subscriber drop
20 or locally by internal or external means. Depending on the source of power PWR, input power may be of alternating or direct current.

A directional coupler 210, which may be in the form of a plug-in module taps, into the broadband serving cable 110.
25 A broadband of radio frequency signals is thus output to highpass filter 220. Highpass filter 220 passes a band of frequencies comprising at least the data carrier frequency or frequencies (in a bi-directional application) and the cable television channel spectrum. Referring briefly to Fig. 4, the
30 cable television spectrum may comprise a frequency band from at least 120 MHz to 350 MHz.

An automatic gain control circuit comprises variable attenuator 230, RF amplifier 233, directional coupler 232, and AGC control circuit 231. The automatic gain control circuit
35 appropriately regulates the broadband RF signal power to fall within established limits.

Also connected to directional coupler 232 is a data

receiver 240 for receiving data from the addressable data transmitter located at headend 100. Data receiver 240 receives data transmitted, for example, over a data carrier of 108.2 megahertz and provides unprocessed data to data decoder 250. In accordance with an established protocol, such data may be in the form of an operation code, a subscriber unique address and associated data. Data decoder 250 processes the data and provides the separately transmitted data to microprocessor 260 for further interpretation in accordance with a built-in algorithm. Microprocessor 260 is most efficiently chosen to alleviate as many responsibilities from any microprocessor provided for an individual subscriber module and so is most conveniently an eight bit microprocessor having eight kilobytes of internal code such as a Motorola 68HC05C8.

Received data may be stored in uninterruptable memory 270 by microprocessor 260. Data may be temporarily stored in memory 270 or more permanently stored and subsequently downloaded when needed to a subscriber module via a serial peripheral interface bus connecting microprocessor 260 with separate microprocessors associated with each provided subscriber module.

Microprocessor 260 consequently interprets both global communications addressed to common control circuitry or communications addressed to unique subscriber modules. If appropriate, microprocessor 260 ignores global or addressed communications to other interdiction apparatus 130 or to converter/decoders 150 (Fig. 1). Examples of global communications peculiar to interdiction apparatus 130 are premium channel frequency data and jamming factor data for each premium channel or channel over which premium programming at a particular point in time is provided via headend 100. Examples of addressed communications include communications comprising premium channel or programming authorization information or communications instructing the common control circuitry to deny or provide service to a particular subscriber.

If two way services over the serving cable are anticipated, a data transmitter (not shown) may be provided in the common control circuitry of Fig. 2 or a separate telephone link from the subscriber location to the headend may be provided. Serial peripheral interface bus 290 may be a two way communications link by way of which link microprocessors 300 (Fig. 3) associated with subscriber modules may, at least, provide status reports to microprocessor 260 upon inquiry.

Radio frequency splitter 280 provides broadband radio frequency signals comprising at least the cable television service spectrum of Fig. 4 separately to each subscriber module that is provided.

If a reverse path is required for special additional services, a signal combiner (not shown) of a plug-in special service module may be provided for receiving communications from each of the four subscriber modules in an opposite manner to splitter 280. Certain data may be transmitted back toward the headend via the special service plug-in module (also, not shown) associated with the additional special service.

Referring more particularly to Fig. 3, there is shown an overall block schematic diagram of a subscriber module in accordance with the present invention. A microprocessor 300 is associated with a particular subscriber module and communicates with microprocessor 260 of Fig. 2 over a serial peripheral interface bus. Microprocessor 300 may comprise an eight bit microprocessor equipped with only two kilobytes of microcode, this microprocessor being relieved of overall control responsibilities by microprocessor 300. Consequently, microprocessor 300 may conveniently comprise a Motorola 68HC05C3 microprocessor or similar unit.

A reverse path may be provided via a lowpass filter 392 to a special service module (not shown in Fig. 2) of common control circuitry as described in Fig. 2 from a corresponding special service module on the subscriber premises. Such a reverse path is completed to the subscriber via terminal OS. Also power may be transmitted up the subscriber drop to the module of Fig. 3 and withdrawn at

terminal OS.

The broadband radio frequency television spectrum signal from Fig. 2 is provided to terminal IS. Referring to the path connecting terminal IS to terminal OS, there are
5 connected in series a service denying switch 389, an amplifier 397, a jamming signal combiner 384, and a high pass filter 391. Service denying switch 389 is under control of microprocessor 300. In the event of an addressed communication from headend 100 indicating, for example, that
10 a subscriber is to be denied service for non-payment of a bill, service denying switch 389 may be opened. In addition, a high frequency amplifier 387 may be powered down under control of microprocessor 300 whenever service is to be denied. Otherwise, amplifier 387 may be set at discrete gain
15 levels, under microprocessor control, to provide supplemental gain to the broadband television signal if a subscriber has a plurality of television receivers over and above a nominal amount.

Jamming signals are introduced at directional combiner
20 385 under microprocessor control. Because of the directional characteristic of amplifier 387, jamming signals cannot inadvertently reach the common control circuitry of Fig. 2 of the serving cable 110. According to a novel aspect of the invention, jamming signals are introduced at a level
25 approximately within a range limited to -2.5 db to +6.5 db or +2dB nominal of the video carrier power level of the unauthorized premium channel frequency to be jammed. They are most conveniently introduced for video carrier jamming approximately within a range of frequencies limited to 100KHz
30 below the video carrier to 200 KHz above the video carrier toward the audio carrier of the channel to be jammed. In accordance with the present interdiction apparatus, the frequency is selectable by the headend 100. This amplitude and frequency range defines an amplitude-frequency window
35 within which the jamming signal should be limited to provide optimal jamming.

This amplitude-frequency window is graphically

illustrated in Figure 8. It has been found through experimentation with a great many TV sets from different manufacturers that optimum jamming occurs if the jamming signal is located within this window. If the jamming signal is more than +6.5 dB greater than the video carrier, adjacent channel interference is likely to occur. If the jamming carrier frequency is more than 100 KHz below the video carrier, lower adjacent channel artifacts often occur. If the jamming carrier frequency is more than 200 KHz above the video carrier, jamming is often inadequate on a number of TV sets. This amplitude-frequency window applies whether one or a plurality of oscillators is used.

According, to another aspect of this invention, the location of the jamming signal within the window may be intentionally varied to thwart pirating as discussed in more detail below.

Highpass filter 391 prevents any return path signals from reaching combiner 385 and passes the broadband spectrum including any jamming signals toward terminal OS. Reverse path signals, for example in this embodiment, if present, may be radio frequency signals below 100 megahertz. The broadband television spectrum is presumed to be in the 100-350 megahertz range consistent with Fig. 4. However, interdiction of premium channel viewing may be allocated anywhere desired within a broader or discontinuous cable television spectrum to be jammed. Consequently, filters 391 and 392 are designed in accordance with this or similarly selected design criteria to block or pass broadband television or reverse path signals as required.

Microprocessor 300 controls four (or other quantity) voltage controlled oscillators 341-344, each of which oscillators jams premium channel frequencies within an allocated continuous range of frequencies. Since premium programming may be transmitted anywhere in the cable television spectrum, the sum of all such allocated portions comprises the entire television spectrum to be jammed. In accordance with the present invention, the television spectrum

to be jammed may comprise discontinuous portions or intentionally overlapping portions.

Referring briefly to Fig. 4, the spectrum allocation to the plurality of four voltage control oscillators in one 5 embodiment will be discussed in view of certain principles. Firstly, it is desirable to eliminate jamming signal harmonic interference to authorized channels within the allocated band. For example, a harmonic of a relatively low frequency signal, for example, 100 MHz can interfere with a channel at a 10 harmonic of this frequency in the upper part of the cable television spectrum. In other words, the allocated band should be limited for an oscillator to fall within one third of an octave, and, consequently all frequency harmonics may be blocked by filters 351, 352, 353 and 354 associated with 15 each oscillator. Oscillator 341 denoted OSC 1, for example, is active in a band extending from 126 to 158 megahertz while filter 351 will block harmonics above the included channels 15-20 of the midband.

Cable headend service providers tend to select premium 20 channel allocations in the midband range covering channels 15-22. Consequently, the band of oscillator 342, for example, may be selected to overlap the band allocated to oscillator 341.

In order to achieve a jamming interval of 20%, each 25 oscillator may be restricted to jamming only four premium channels. As will be described in connection with a discussion of Figs. 5, 6 and 7, jamming depth may be automatically increased for a particular subscriber dependent upon the subscriber's level of service. Also, by allocating 30 an overlap of bands as between first and second oscillators 341 and 342, for example, all eight channels of the midband may be jammed by means of the present interdiction apparatus leaving two channels of the highband which still may be jammed via oscillator 342. Consequently, according to Fig. 4, 35 oscillator OSC1 may jam four of the six allocated channel frequencies of the midband while oscillator OSC2 may jam an overlapping band comprising channels 19-22 of the midband and

channels 7-10 of the highband. The range of jamming signal frequencies for oscillator OSC2 is selected within the range of 150-194 megahertz consistent with the desirable elimination of harmonic interference.

5 Consistent with these design principles, no band overlap is shown for oscillator OSC3 or oscillator OSC4. Nevertheless, the respective frequency ranges of 198-254 megahertz and 258-326 megahertz of these oscillators eliminate any danger of harmonic interference. Low pass filters 353 and
10 354 cut off harmonic frequencies above the upper limits of these respective ranges. Oscillator OSC3 provides jamming signals for jamming four premium channels selected from channels 11-13 of the highband and channels 23-29 of the superband. Eight premium channels may be jammed at a reduced
15 jamming factor of these ten channels. Oscillator OSC4 is provided for jamming from channel 30 in the superband to channel 41 extending into the hyperband. Four channels of these twelve may be jammed at a 20% jamming interval; however, eight may be jammed at a reduced jamming factor.

20 Microprocessor 300 is connected by a bus system to memory and buffer circuits comprising RAM's 311 and 312 and buffer 310. Microprocessor 300 operates at a clock frequency of, for example, four megahertz provided by clock 336. Counter 335 is shown as a separate element; however, counter
25 335 is provided essentially for counting the output frequencies of jamming oscillators 341-344 during a calibration mode of operation and so may comprise an element of microprocessor 300.

Microprocessor 300 is also connected to digital to
30 analog converter 320. During a normal mode of operation, digital to analog converter 320 converts a ten bit voltage control word to analog voltage outputs which are, in turn, provided to analog multiplexer 330. The analog voltage outputs of the analog multiplexer 330 are stored and held at
35 sample and hold circuits 337-340 for application to oscillators 341-344. Via a two bit parallel select bus, analog voltage signal outputs are sequentially gated analog

multiplexer 330 over leads FREQ 1-4 toward the oscillators 341-344. In accordance with the principles of the present invention, these signals may be provided in a pseudorandom sequence to thwart pirating attempts as will be described in reference to Fig. 6.

Microprocessor 300 is connected to each oscillator 341-344 via respective oscillator power lines OPWR1-4 for actuating the oscillators. Each oscillator may be powered down during a normal mode of operation if a subscriber is authorized to receive all channels within its allocated band at one point in time. Furthermore, during a calibration mode, one oscillator may be powered up for calibration while all other oscillators are powered down.

Microprocessor 300 is further connected to four high frequency PIN diode switches 361-364. During a normal mode of operation, these switches are selectively opened for a brief interval for, for example, sixteen microseconds while an associated oscillator changes or hops from one jamming signal frequency output to another. Nevertheless, assuming four channel jamming by a particular oscillator at a jam factor of four, a four thousand hertz frequency hopping rate is easily achievable via these PIN diode switches.

Also connected to the outputs of each oscillator are associated low pass filters which serve to cut off all harmonics of jamming signal frequency outputs. These low pass filters may be connected either to the inputs or to the outputs of switches 361-364 although connection in series between its associated oscillator and high frequency switch is shown in Fig. 3.

The jamming signal outputs of all four oscillators are combined at signal combiner 365. From signal combiner 365, the combined output is directionally coupled by coupler 370 to programmable prescaler 375 and to signal attenuator 380.

Programmable prescaler 375 is only powered via lead PREPWR when required during a calibration mode. In accordance with a programmable divide-by factor, a divided down output frequency is provided to microprocessor 300 for counting.

When powered down, no output signal results.

During a normal mode of operation, the combined jamming signal outputs of attenuator 380 are combined at directional coupler 385 with the passed incoming broadband television signal from the common control circuit of Fig. 2. As the subscriber is presumed to have paid their bill, switch 389 and amplifier 387 are assumed to be powered. As a result of the combining of jamming signals with the broadband spectrum (thus far transmitted in the clear), the subscriber will only receive in the clear premium or restricted programming which the subscriber is authorized to receive.

Referring more particularly to Fig. 5, there is shown a block schematic diagram of one embodiment of a feedback loop useful in describing the calibration mode of operation. The calibration mode, occupying a fraction of a second, assures relatively frequency stable operation during a normal mode of operation. Furthermore, because of the calibration mode, there is no requirement for the application of slow conventional frequency locking techniques and a high operation frequency hopping rate of four thousand hertz may be achieved during the normal mode of operation. The embodiment shows the calibration of one particular oscillator OSC. The depicted loop indicates an application specific integrated circuit ASIC connected to subscriber module microprocessor 300. This circuit ASIC may be clocked at twice the microprocessor rate and comprise the previously discussed voltage control word memory RAM as well as programmable prescaler 375. A word adjust and select bus 501 is shown which may separately access and adjust all voltage control words in voltage control word memory RAM. When addressed, the voltage control word memory is connected via bus 511 to digital to analog converter 320. Digital to analog converter 320 is connected via sample and hold circuit SH to oscillator OSC to which power is applied under microprocessor control via lead OPWR. Via directional coupler 370, the jamming signal output of oscillator OSC is fed back toward microprocessor 300. At fixed prescaler 376, the high frequency output is divided down by a fixed divide-

by factor. The divided down jamming frequency output is then output to programmable prescaler 375. Programmable prescaler 375 is under control of microprocessor 300. Responsive to premium channel frequency data transmitted from the headend
5 to microprocessor 260 of Fig. 2, microprocessor 260 in turn generates divide by factor and time between count data for transmittal to microprocessor 300 via the serial peripheral interface bus (Fig.'s 2 and 3). Microprocessor 300 programs the divide by factor of programmable prescaler 375 via lead
10 502 and receives a countable frequency output of programmable prescaler 375 via lead 503. Microprocessor 300 then counts the output at included counter 335.

The provision of application specific integrated circuit ASIC assists in miniaturizing the subscriber module
15 of Fig. 3 and relieves the outboard memory requirements of microprocessor 300. On the other hand, the provision of a limited voltage control word memory in circuit ASIC may restrict the opportunity of microprocessor 300 to reallocate addressable slots to other oscillators when one oscillator is
20 powered down as will be described in greater detail in reference to Fig. 6. The provision of a second or fixed prescaler in comparison with the single programmable prescaler shown in Fig. 3 is desirable if the frequency range of the television spectrum to be jammed extends into the hyperband.

25 Referring now to Fig. 6, there is shown one embodiment of a voltage control word memory having sixty-four memory locations with addresses 1-64. At every fourth memory location 1, 5, 9 and so on is located a voltage control word associated with a first oscillator. For the convenience of
30 establishing a convention for discussion, f10... f1E will be assumed to refer to sixteen frequency control words for a first oscillator OSC1 and are numbered in hexadecimal notation from 0-E. As indicated above in reference to circuit ASIC memory requirements, the sixteen memory slots may be
35 permanently associated with oscillator OSC1; however, such a design choice limits the freedom of reallocating voltage control words to other oscillators.

Voltage control words are entered into voltage control word memory for each oscillator in sequence provided the oscillator will be applied for jamming. First, it will be assumed that all four oscillators will be applied, each for 5 jamming four premium channels. As will be seen, this is a simplified assumption which assumes a subscriber is authorized to receive no premium channels and, furthermore, it will be assumed that all premium channels are to be jammed at the same jam factor four.

10 In this example, sixteen voltage control words will be entered in memory for each oscillator, four of which control words may be the same, each four similar control words being related to one premium channel frequency to be jammed. Thus, four groups of four similar control words are entered into 15 sixteen memory locations 1, 5, 9, 13...61 for oscillator OSC1. These are indicated as f10 to f1E. In a similar manner, sixteen voltage control words are entered into memory locations 2, 6, 10, 14...62 for oscillator OSC2. These are indicated as f20...f2E. Then, sixteen voltage control words 20 are entered into memory locations 3, 7, 11, 15...63 for oscillator OSC3, indicated as f30...f3E. Lastly, sixteen voltage control words are entered into memory locations 4, 8, 12, 16...64 for oscillator OSC4, indicated as f40...f4E.

The calibration algorithm for loading a first ten bit 25 voltage control word f10 into a first memory location 1 for a first oscillator OSC 1 will now be described in some detail. From the down-loaded frequency data from microprocessor 260, a first programmable divide-by factor is transmitted via lead 502 to set programmable prescaler 375. All other oscillators 30 OSC2-4 are powered down via leads OPWR2-4, and oscillator OSC1 is powered up via lead OPWR1 (shown in Fig. 5 as oscillator OSC and lead OPWR respectively).

From the premium channel frequency data, a first ten bit voltage control word f10 is stored in memory location 1 35 representing a first best estimate of jamming frequency by microprocessor 300 via bus 501. The word is transmitted to digital to analog converter 320 where it is converted to an

analog voltage. The analog multiplexer (not shown in Fig. 5) selects a lead FREQ1 from the multiplexer to oscillator OSC1. Consequently, the analog voltage output of the digital to analog converter is provided to sample and hold circuit SH or
5 337 for application to oscillator OSC1. Signal combiner 365 (not shown in Fig. 5 for simplicity) only passes the jamming signal output from oscillator OSC1 to directional coupler 370 because all other oscillators OSC2-4 are powered down at this time. Via directional coupler 370, the jamming signal output
10 is provided to fixed prescaler 376. Fixed prescaler 376 divides down the output frequency of the oscillator OSC 1 to a first frequency. According to the divide by factor loaded into programmable prescaler 375, the first frequency output of fixed prescaler 376 is further divided down to a frequency
15 which may be counted by counter 335 of microprocessor 300. Recognizing that the oscillator output frequency may be hundreds of megahertz, the frequency provided via lead 503 should be sufficiently divided down to be counted with reasonable accuracy. Since the fixed time between counts is
20 known to microprocessor 300 having been downloaded from microprocessor 260, counter 335 counts the frequency input on lead 503. The resulting count is compared with the expected count and the microprocessor adjusts the control word accordingly. As a result, microprocessor 300 repeatedly
25 enters the algorithm until the voltage control word stored in memory as accurately as possible reflects the premium channel frequency to be jammed. Then, this process is repeated four times for four premium channel frequencies to be jammed by the oscillator OSC.

30 During the process of loading the four premium channel frequencies for a particular oscillator into the voltage control word memory, there are two subordinate schemes by which the four voltage control words for a single premium channel may be intentionally varied. In a first subordinate
35 scheme, via headend 100, four different frequencies may be intentionally selected with reference to one premium channel. Given a resolution of 50 kilohertz provided by the least

significant bit positions of a ten bit voltage control word, the four different frequencies may be selected by headend 100 anywhere within the range of 100. KHz below the video carrier to 200 KHz above the video carrier for most effective jamming.

5 In an alternative embodiment, microprocessor 300 may be programmed to intentionally vary the entered voltage control word to be at or about the expected downloaded frequency, for example, at 50 KHz above or below the expected frequency. Consequently, if the headend selects only one frequency for
10 a first premium channel, for example, at 100 KHz above the video carrier, then voltage control words will be entered into memory equivalent to video carrier plus 50 KHz, 100 KHz and 150 KHz. Both embodiments thwart pirates' attempts to notch out the jamming signal frequency which is intentionally
15 varied.

Jamming factor is a term related to the loading of the sixteen voltage control words into voltage control word memory for a particular oscillator. A jamming factor is selected for each premium channel and is globally transmitted from the
20 headend. If four premium channels are to be jammed by each of four oscillators OSC1-4 and all are to be jammed at the same jamming interval, each has a jamming factor of four. If a subscriber subscribes to all four premium channels associated with oscillator OSC1, then oscillator OSC1 may be
25 powered down and no voltage control words entered in memory during calibration for this oscillator. If a subscriber subscribes to two of the four channels, the microprocessor may allocate the sixteen control words for the first oscillator to the two unauthorized premium channel frequencies to be
30 jammed. Consequently, the microprocessor may allocate eight control words each to jamming the two unauthorized premium channels thus automatically increasing the jamming interval or depth of jamming based on the jamming factor and the given reduced level of premium program authorization. Jamming
35 factor may be intentionally selected, for example, at a high level, for example, eight for one especially sensitive program in relation to two other channels to be jammed by the same

oscillator which may be allocated jam factors of four each, the total of all such jam factors being equal to the maximum number of voltage control words, in this example, sixteen associated with the oscillator.

5 Voltage control words may be read from memory or written into memory so they may be read out in a particular pseudo random sequence so that a pirate would have to know the pseudorandom sequence in order to appropriately time any notch filtering. For example, let f11-f14 be the four premium
10 channel frequencies to be jammed by oscillator OSC1. Addresses 1, 5, 9, and 13 may store voltage control words for f11, f12, f13 and f14, respectively. However, the next four addresses 17, 21, 25, and 29 may store the voltage control words in a different order, for example, f14, f13, f12, f11
15 respectively. The order may be further varied in the remaining eight addresses so, when the voltage control words are applied to oscillator OSC 1 during a normal mode of operation, the output frequency of the jamming signal will vary according to the pseudorandom sequence of data entry.

20 The calibration mode is entered at initial turn-on to generate the sixty-four voltage control words for storage in voltage control word memory corresponding to the desired jamming signal frequencies. Periodically, the subscriber module reenters the calibration mode to update the control
25 words for drift which may result from either the oscillator or the digital to analog converter operation. Such drift if maintained within, for example, 50 kilohertz of the selected frequency is actually desirable in that it further complicates the efforts of a would-be pirate. Also, as already indicated,
30 the periodically performed calibration mode permits a higher rate of frequency hopping, for example, four kilohertz during normal operation than would be possible with conventional frequency control methods such as phase locked loops. Calibration requires but a fraction of a second and,
35 consequently, no intelligible television information may be obtained at a television receiver tuned to an unauthorized premium channel.

Referring now more particularly to Figs. 6 and 7 with reference to the schematic block diagram of Fig. 3, the normal mode of operation will now be explained. Referring first to fig. 3, microprocessor 300 upon entering a normal mode of operation causes a first voltage control word stored in memory address 1 of the voltage control word memory of Fig. 6 to be transmitted toward oscillator OSC1. Digital to analog converter 320 converts the ten bit word 0010110101 to an analog voltage level. Under control of a two bit select bus, analog multiplexer 330 selects lead $FREQ_1$ for transmitting the analog voltage signal for storage and holding at sample and hold circuit 337. All four oscillators are presumed to be powered for this example under control of microprocessor 300 via leads $OPWR_1-4$. Consequently, powered-up oscillator OSC1 provides a jamming signal frequency output $FREQ_2$ consistent with the analog voltage signal input provided via analog multiplexer 330.

Referring to Fig. 7, the normal mode of operation for the example under discussion is shown in the form of a timing diagram. AT the output of the digital to analog converter is shown at time t_0 an analog voltage level representing frequency $FREQ_1$ for oscillator OSC1. Also, during time interval $t_0 - t_1$, the analog multiplexer 330 is shown connecting the digital to analog converter 320 to oscillator OSC1. While the analog multiplexer is only connected to oscillator OSC1 for the duration t_0-t_1 , the applied analog voltage is stored and held for the duration t_0-t_4 . Consequently, the output of oscillator OSC1 is shown continuously applied from time t_0-t_4 .

Under control of microprocessor 300 via lead $OSSW_1$, switch 361 is briefly opened while frequency $FREQ_1$ is established at the output of oscillator OSC1 and then immediately closed. Switch 361 stays closed for the duration until the output of oscillator OSC1 hops from frequency $FREQ_1$ to $FREQ_2$. Just prior to time t_4 , switch 361 is again opened in accordance with signal $OSSW_1$. Consequently at the output of switch 361, the jamming signal output of oscillator

341 is briefly interrupted.

At time t_4 , the digital to analog converter 320 is signaled to change the output frequency of oscillator OSC1 to frequency $FREQ\ 2$. As before, the analog multiplexer 330 gates an analog voltage level, this time representing frequency $FREQ\ 2$ to be held at sample and hold circuit 337. As a result, oscillator OSC2 now provides a jamming signal frequency output consistent with frequency $FREQ\ 2$ until time t_8 .

Meanwhile, switch 361 which was opened shortly before time t_4 in accordance with switch control signal OSSW1 is again closed at a point in time shortly after time t_4 . At any point in time during a normal mode of operation when one of the high frequency switches 361-364 is opened, there will result a loss of a portion of the overall jamming interval during which a jamming signal would be applied. Nevertheless, the resulting danger of the presence of no switches 361-364 is that during a hopping from one frequency to the next, an undesirable transition signal may result at a frequency and level which may distort authorized premium programing. If four premium program channel frequencies are to be jammed by a particular oscillator, each such period of an open state of a normally closed high frequency switch 361-364 amounts to no more than 5% of the overall interval t_0 - t_{64} (not shown).

In a similar manner, a first frequency $FREQ\ 1$ is established for oscillator OSC2. Referring again to Fig. 6, it will be seen that at memory address 2 is voltage control word 1010010110 which is provided toward oscillator OSC2. In accordance with Fig. 7, at time t_1 an analog voltage level is output from digital to analog converter 320 representing this word. At a time just prior to time t_1 , switch 362 is opened in accordance with signal OSSW2. Once frequency $FREQ\ 1$ is established at the output of oscillator OSC2 or at a time just after time t_1 , switch 362 is again closed in accordance with signal OSSW2 provided by microprocessor 300.

As the normal mode of operation continues, all sixty-four memory locations shown in Fig. 6 are sequentially addressed and provided for operating oscillators OSC1-4. In

accordance with Fig. 7, only the first seven words are represented as having been provided for selecting the first three frequencies for oscillator OSC1 and two frequencies each for oscillators OSC2-4; however, the process for controlling all sixteen frequencies for each oscillator may follow in the sequence shown or intentionally vary.

In order to thwart pirates and referring to Fig. 7 for oscillator OSC1, it may be seen how frequencies may be output in a pseudorandom sequence. Output frequencies $FREQ\ 1$, $FREQ\ 2$, $FREQ\ 3$, $FREQ\ 4$ are shown in intervals t_0-t_4 , t_4-t_8 , t_8-t_{12} , and inferentially, $t_{12}-t_{16}$ respectively. In the next intervals, the frequencies may be provided, instead, in the sequence $FREQ\ 4$, $FREQ\ 3$, $FREQ\ 2$, and $FREQ\ 1$. Then, in the next successive intervals the frequencies may be provided in yet a third different sequence, for example, $FREQ\ 2$, $FREQ\ 3$, $FREQ\ 4$, $FREQ\ 1$. During the last four successive intervals extending from t_{48} to t_{64} , the order of applied frequencies may be altered again, for example, $FREQ\ 3$, $FREQ\ 4$, $FREQ\ 1$, $FREQ\ 2$. The pseudorandom sequence may be defined and downloaded from the headend or developed internally by either microprocessor 260 of Fig. 2 or microprocessor 300 of Fig. 3.

Many variations of the preferred embodiments described above will be readily apparent to one of ordinary skill in the art. The present invention is not limited to the preferred embodiments and is only limited by the claims appended hereto.

CLAIMS

1. A cable television premium channel interdiction apparatus for selectively jamming certain premium programming transmitted to a subscriber, wherein the premium channel is
5 characterized by a video carrier having a video carrier frequency and a video carrier power level, said apparatus comprising:

one or more controlled oscillator means for producing a jamming signal having a jamming signal carrier;
10 and

means for interdicting said jamming signal into said premium channel;

wherein said jamming signal carrier is limited to a range of frequencies from 100 KHz below said video carrier
15 frequency to 200 KHz above said video carrier frequency; and

wherein said jamming signal carrier is limited to a range of amplitudes from -2.5 dB to +6.5 dB of the video carrier power level.

2. The cable television interdiction apparatus of
20 claim 1 wherein the number of controlled oscillators is four.

3. Cable television premium channel interdiction apparatus for selectively jamming unauthorized premium programming transmitted to a subscriber comprising:

microprocessor actuation and control means for
25 selectively actuating and controlling a plurality of n jamming frequencies provided by a plurality of m controlled oscillators, m being less than or equal to n , a maximum of m jamming frequencies being applied for jamming unauthorized premium programming transmitted to a particular subscriber at
30 one point in time, the microprocessor actuation and control means having a calibration mode of operation and a normal mode of operation, and, during a normal mode of operation, a frequency hopping rate on the order of four thousand hertz is providable wherein said jamming frequency is limited to be
35 within a range of frequencies extending from 100 KHz below the frequency of a video carrier of a premium channel to be jammed to 200 KHz above the frequency of a video carrier of a premium

channel to be jammed and wherein the amplitude of a jamming signal is within the range of - 2.5 dB to 6.5 dB of the power level of the video carrier power level of the premium channel to be jammed.

5 4. A cable television premium channel interdiction method for selectively jamming unauthorized premium programming transmitted to a subscriber comprising the steps of:

 receiving globally transmitted frequency and
10 jamming factor data for each premium channel,

 receiving addressably transmitted channel or premium programming authorization data,

 generating and storing control word data responsive to the frequency, jamming factor and authorization
15 data and

 sequentially applying jamming signals to unauthorized premium programming responsive to the stored control word data;

 wherein the jamming signals may be applied
20 anywhere within a range of 100 KHz below to 200 KHz above the video carrier of a particular premium channel to be jammed.

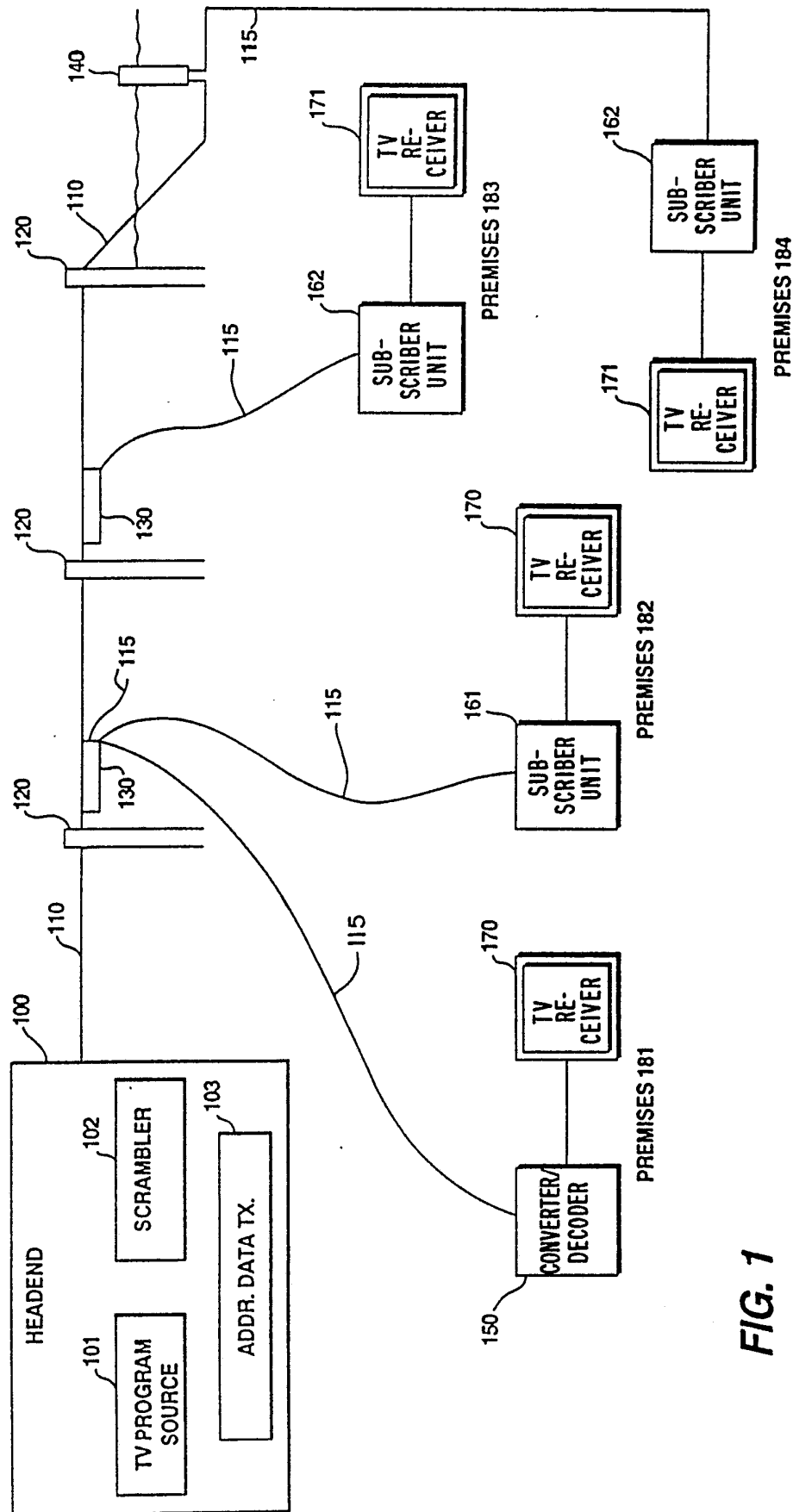
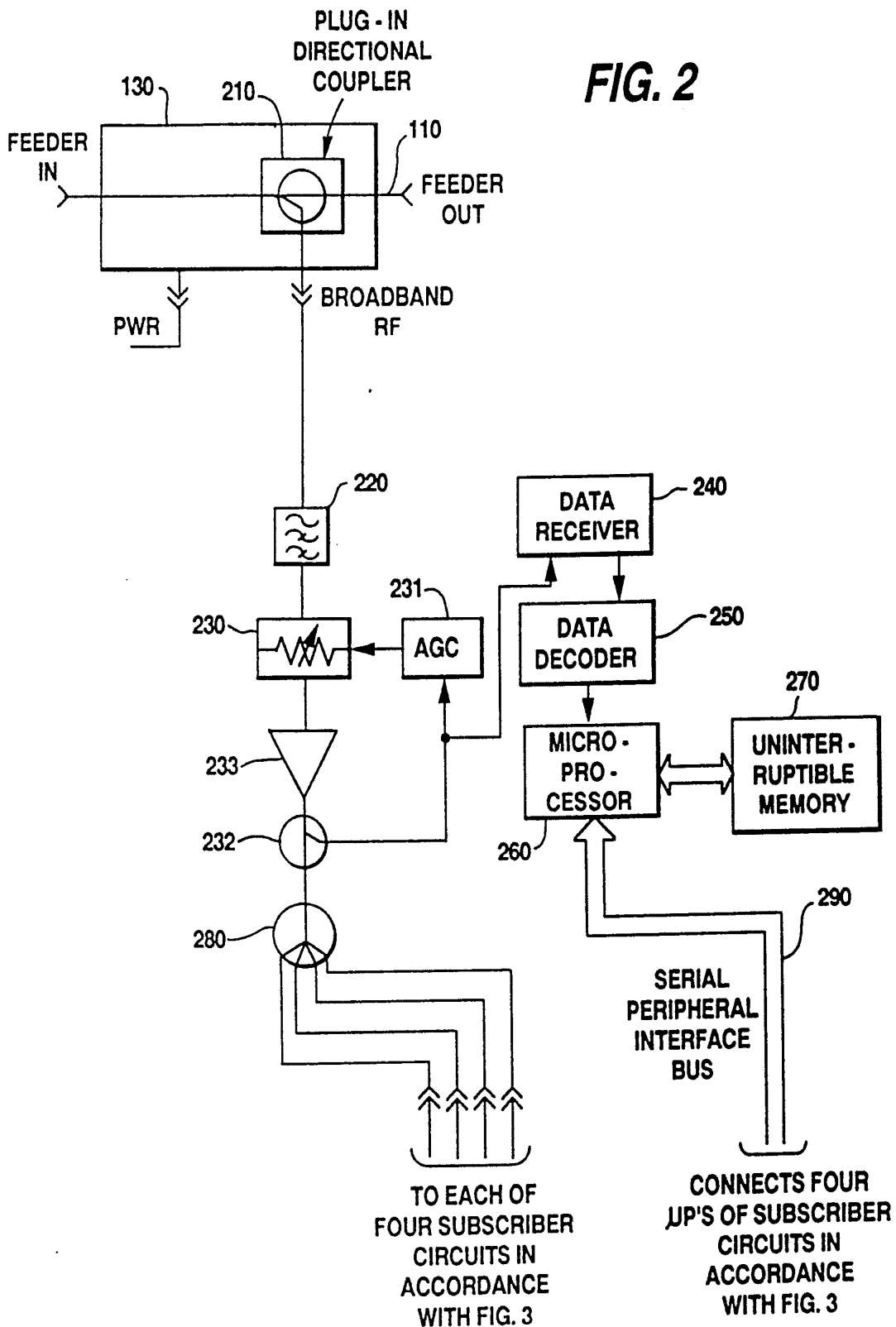

FIG. 1



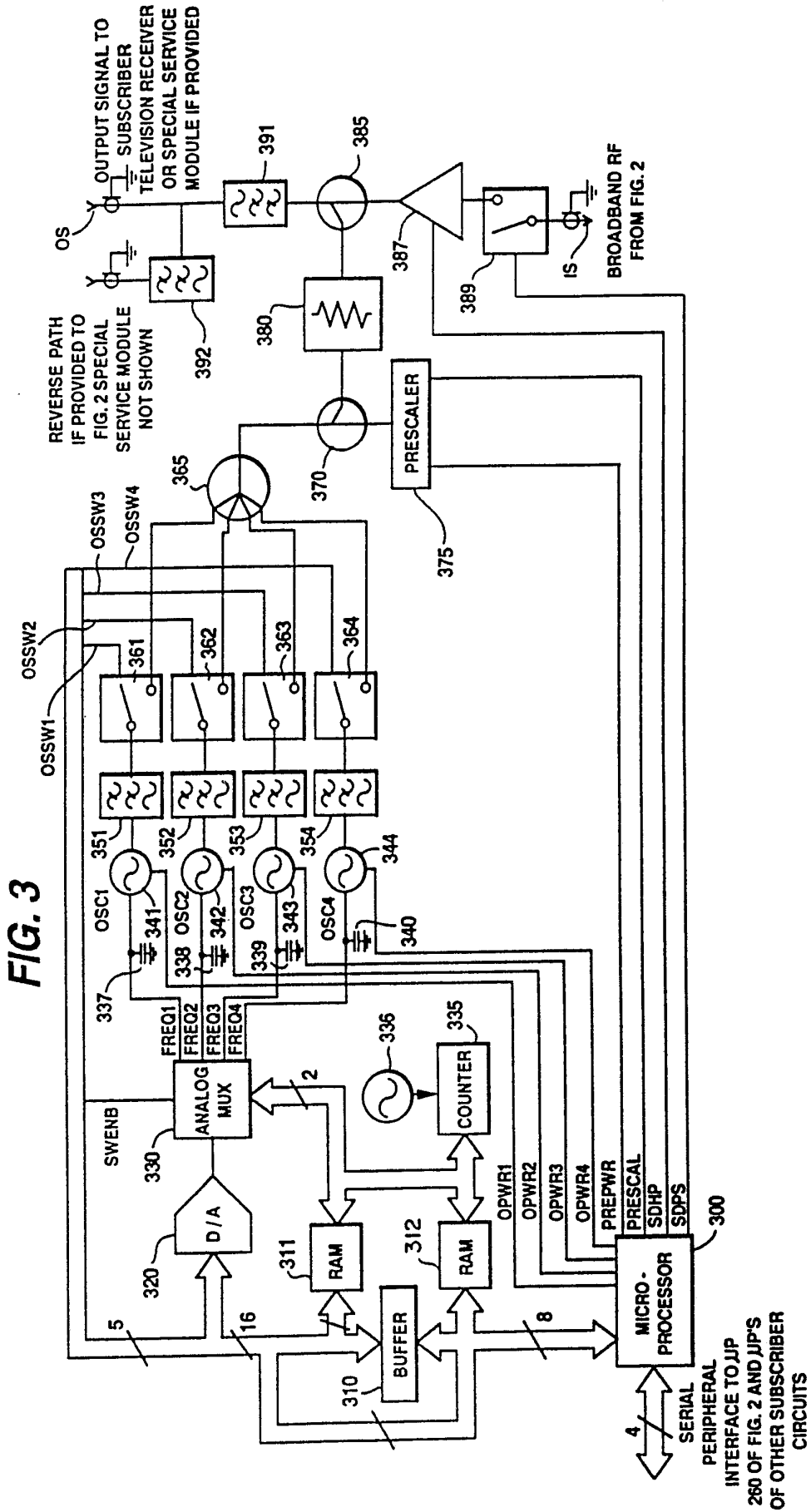
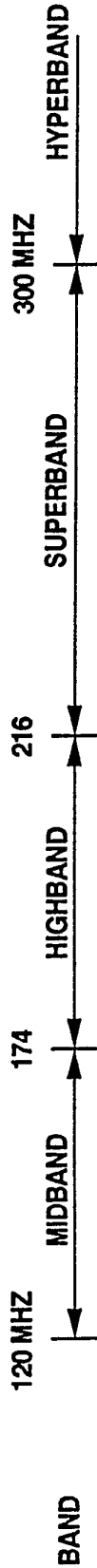

FIG. 3

FIG. 4



BAND	15	20	22	7	10	13	23	25	30	35
EIA CHANNEL	15	20	22	7	10	13	23	25	30	35
FREQUENCY	127.25	175.25	175.25	175.25	217.25	217.25	217.25	259.25	259.25	289.25
		JAM 4 OF 6		OSC 1					JAM 4 OR 8 OF 10	OSC 3
			JAM 4 OF 8		OSC 2					
										JAM 4 OR 8 OF 12
										OSC 4

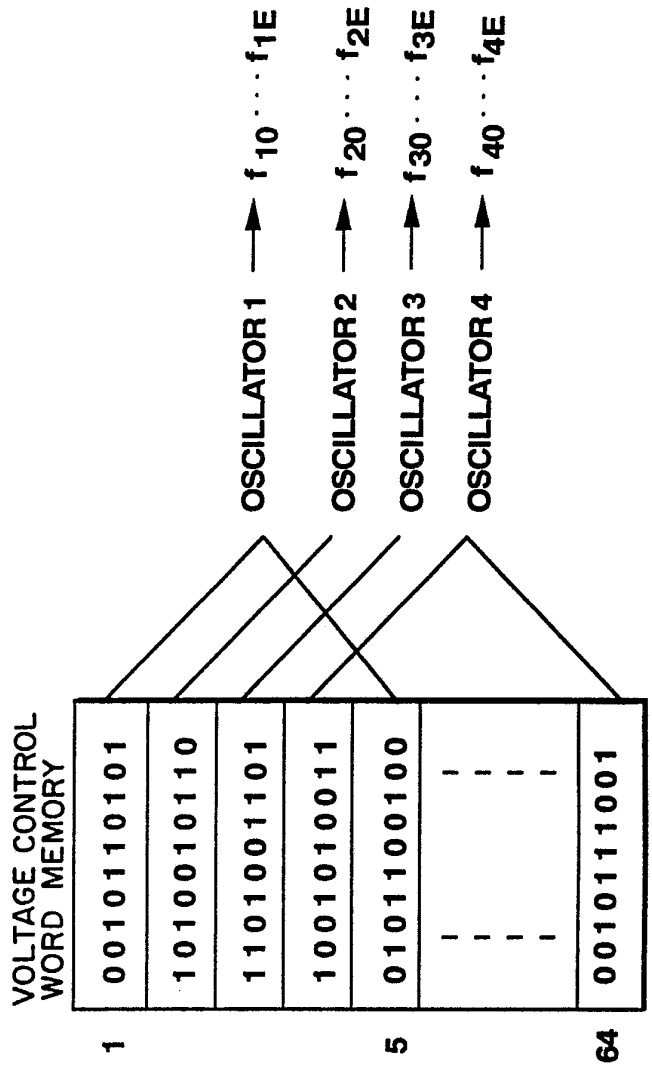
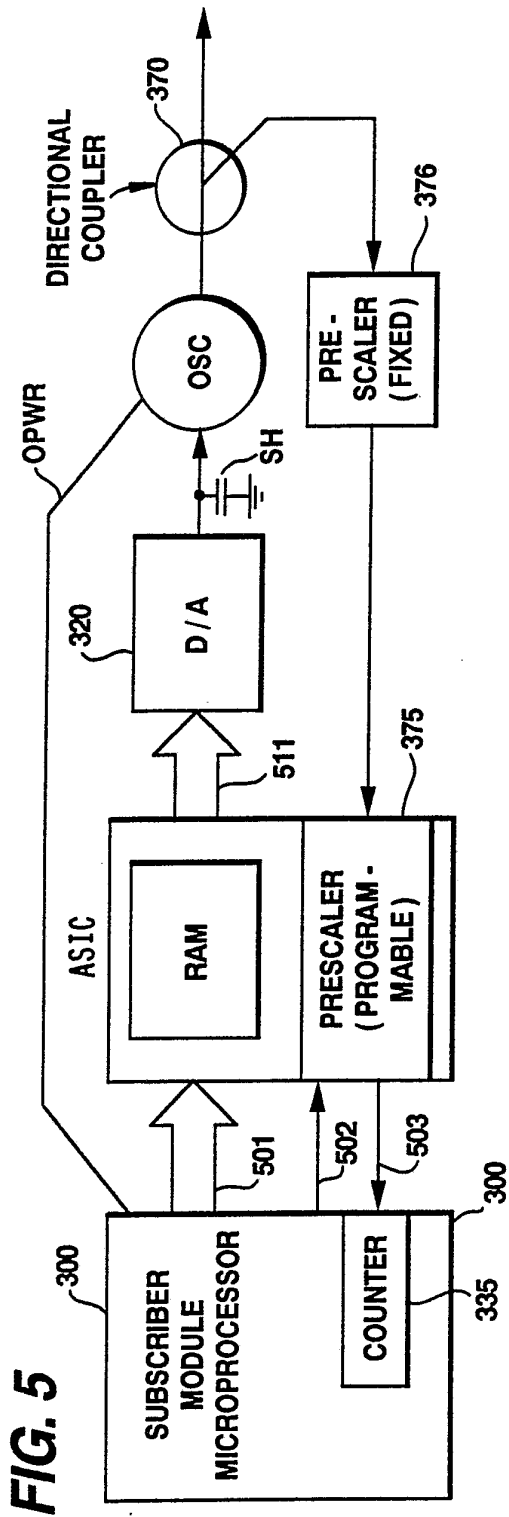

FIG. 7

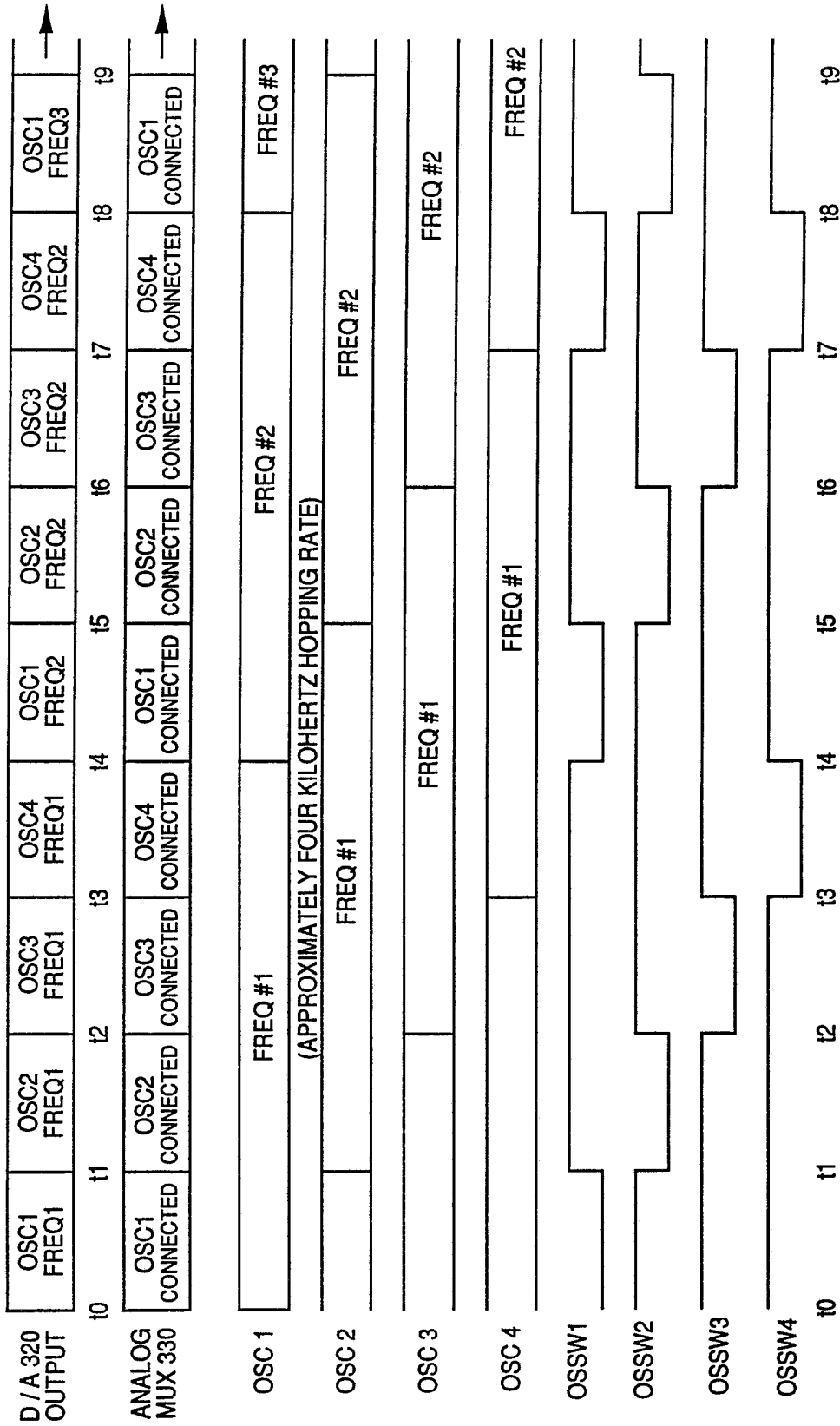
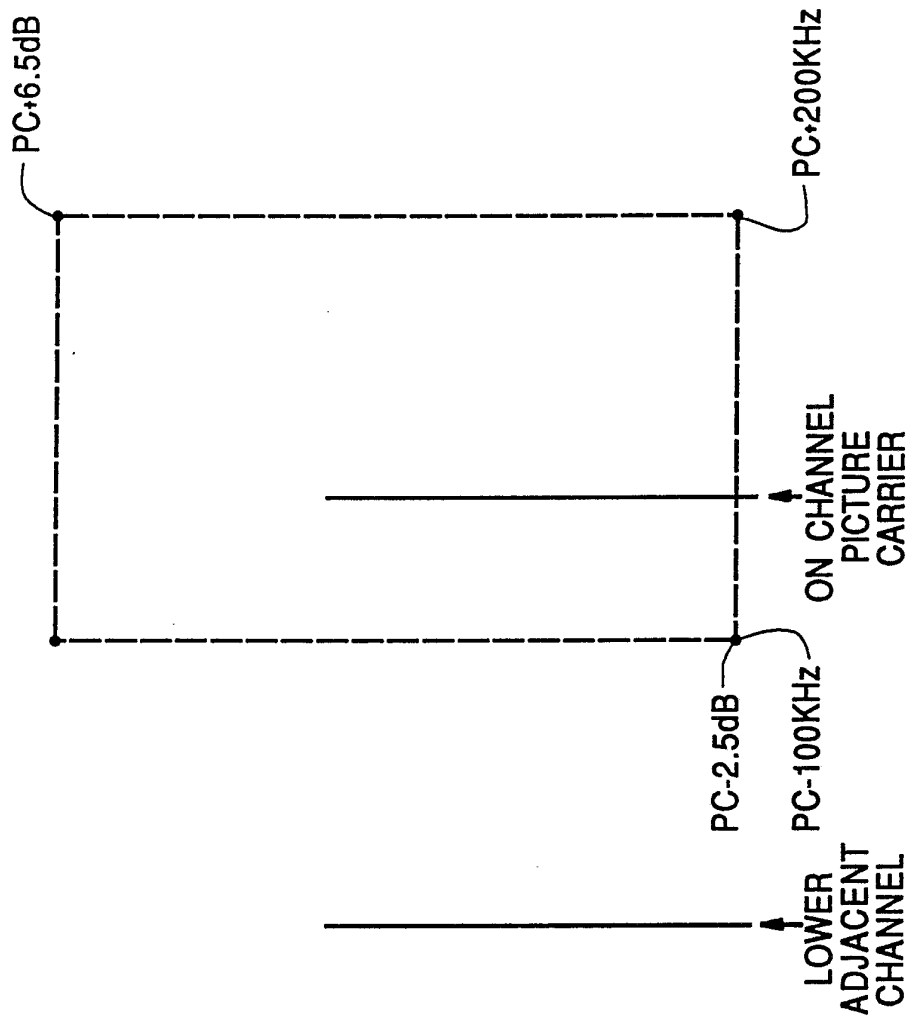

FIG. 8



INTERNATIONAL SEARCH REPORT

International Application No **PCT/US90/07185**

I. CLASSIFICATION OF SUBJECT MATTER (if several classification symbols apply, indicate all) ³		
According to International Patent Classification (IPC) or to both National Classification and IPC		
IPC(5): HO4N 7/167 US CL.: 380/7		
II. FIELDS SEARCHED		
Minimum Documentation Searched ⁴		
Classification System	Classification Symbols	
US	380/7,20 455/1	
Documentation Searched other than Minimum Documentation to the Extent that such Documents are Included in the Fields Searched ⁵		
III. DOCUMENTS CONSIDERED TO BE RELEVANT ¹⁴		
Category *	Citation of Document, ¹⁶ with indication, where appropriate, of the relevant passages ¹⁷	Relevant to Claim No. ¹⁸
Y	US, A, 4,450,481 (DICKINSON) 22 May 1984 See entire document.	1-3
Y	US, A, 4,769,838 (HASEGAWA) 06 September 1988 See entire document.	1-3
Y,P	US, A, 4,912,760 (WEST, JR.) 27 March 1990 See entire document.	3,4
<p>* Special categories of cited documents: ¹⁵</p> <p>"A" document defining the general state of the art which is not considered to be of particular relevance</p> <p>"E" earlier document but published on or after the international filing date</p> <p>"L" document which may throw doubts on priority claim(s) or which is cited to establish the publication date of another citation or other special reason (as specified)</p> <p>"O" document referring to an oral disclosure, use, exhibition or other means</p> <p>"P" document published prior to the international filing date but later than the priority date claimed</p> <p>"T" later document published after the international filing date or priority date and not in conflict with the application but cited to understand the principle or theory underlying the invention</p> <p>"X" document of particular relevance; the claimed invention cannot be considered novel or cannot be considered to involve an inventive step</p> <p>"Y" document of particular relevance; the claimed invention cannot be considered to involve an inventive step when the document is combined with one or more other such documents, such combination being obvious to a person skilled in the art.</p> <p>"&" document member of the same patent family</p>		
IV. CERTIFICATION		
Date of the Actual Completion of the International Search ¹	Date of Mailing of this International Search Report ²	
01 FEBRUARY 1991	14 FEB 1991	
International Searching Authority ¹	Signature of Authorized Officer ³	
ISA/US	INTERNATIONAL DIVISION LINDA J. WALLACE <i>Nginta Nquyeu</i>	