

(No Model.)

2 Sheets—Sheet 1.

T. W. STUEBER.
RAILWAY SIGNALING APPARATUS.

No. 568,218.

Patented Sept. 22, 1896.

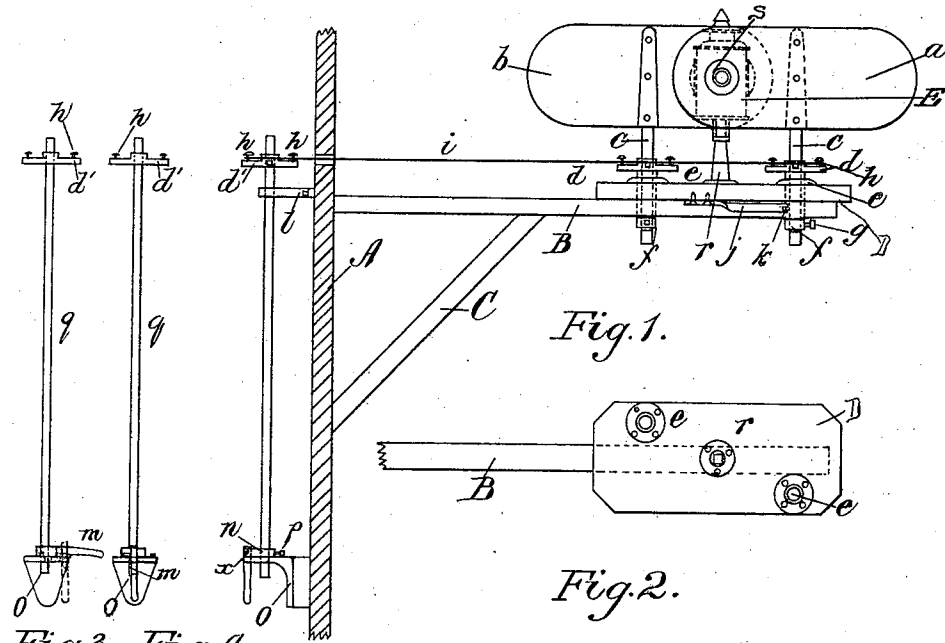
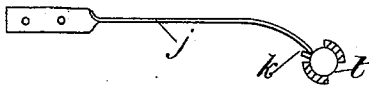
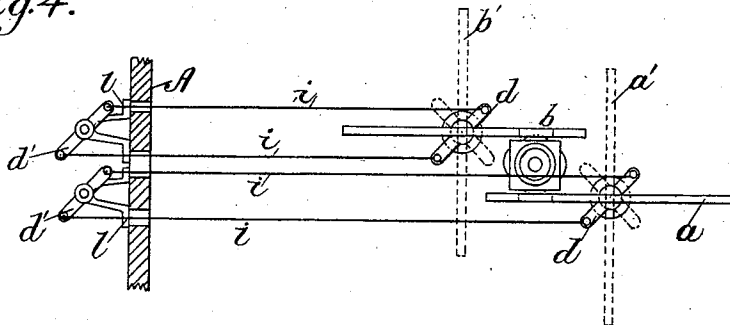

Fig. 3. Fig. 4.



WITNESSES:
William G. Hayes
Clyde C. Farmer

Theodore W. Stueber INVENTOR

BY E. C. Ward

ATTORNEY.

(No Model.)

2 Sheets—Sheet 2.

T. W. STUEBER.
RAILWAY SIGNALING APPARATUS.

No. 568,218.

Patented Sept. 22, 1896.

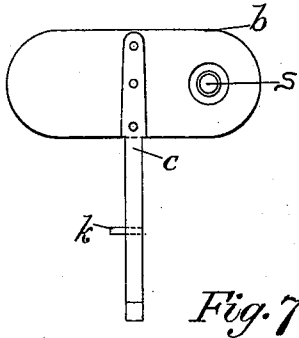

Fig. 7.

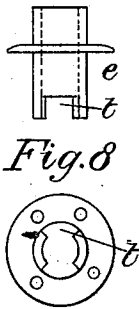

Fig. 8.

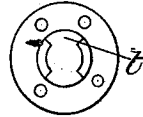

Fig. 9.

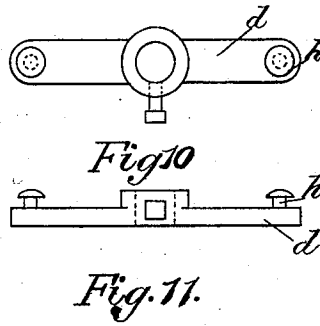

Fig. 10.

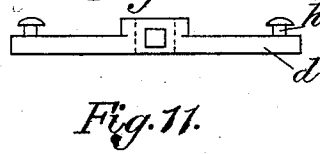

Fig. 11.

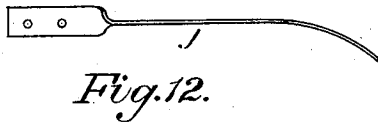

Fig. 12.

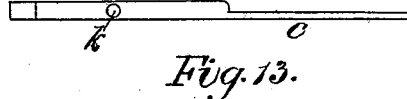

Fig. 13.

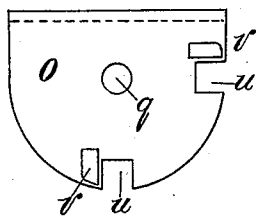

Fig. 14.

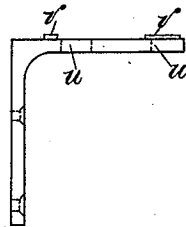

Fig. 15.

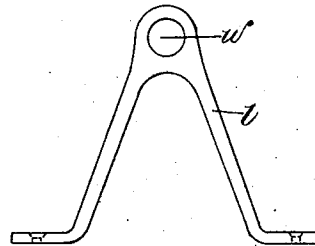

Fig. 16.

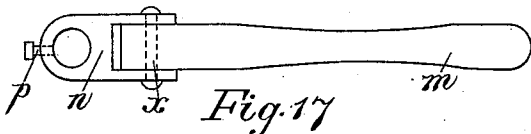

Fig. 17.

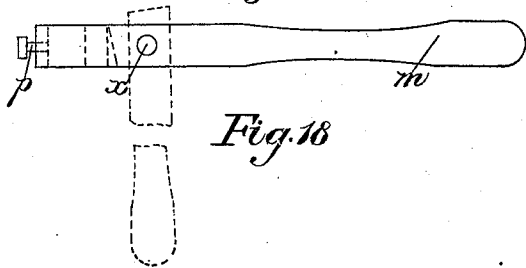

Fig. 18.

WITNESSES:
William G. Hayes
Clyde C. Farmer

Theodore W. Stueber INVENTOR

BY E. C. Ward

ATTORNEY.

UNITED STATES PATENT OFFICE.

THEODORE W. STUEBER, OF PARSONS, KANSAS.

RAILWAY SIGNALING APPARATUS.

SPECIFICATION forming part of Letters Patent No. 568,218, dated September 22, 1896.

Application filed June 27, 1896. Serial No. 597,234. (No model.)

To all whom it may concern:

Be it known that I, THEODORE W. STUEBER, a citizen of the United States, residing at the city of Parsons, in the county of Labette and State of Kansas, have invented certain new and useful Improvements in Railway Signaling Apparatus; and I do declare the following to be a full, clear, and exact description of the invention, such as will enable others skilled in the art to which it appertains to make and use the same, reference being had to the accompanying drawings, and to the letters of reference marked thereon, which form a part of this specification.

My invention relates to improvements in railway signaling apparatus. The apparatus commonly used has a semaphore and is so constructed as to occupy space on the depot-platform, generally in front of the bay-window occupied by the telegraph-operator or station-agent. The depot-platform should be free for the use of passengers to enter and come out of cars and for handling baggage and freight, and the apparatus generally used, as aforesaid, is costly, inconvenient, and unhandy to operate.

The object of my invention is to overcome the objections aforesaid and to provide a cheap, simple, and handy apparatus to use in signaling railway-trains. I attain these objects by the means shown in the accompanying drawings, in which similar letters refer to similar parts throughout the drawings.

Figure 1 is an elevation showing both signals at "danger" and showing a section of the wall of the depot. Fig. 2 shows the place of the stems of the signal-boards and lamp. Fig. 3 shows the position of handle or lever *m* when the track is clear. Fig. 4 gives the position of the handle or lever *m* at "danger" when the track is not clear. Fig. 5 denotes the action of the signaling apparatus. Fig. 6 gives the action of the spring *j*. Fig. 7 is one signal-board with its stem, bull's-eye, and pin. Fig. 8 shows a socket and slot. Fig. 9 is an end view of socket *e*. Fig. 10 is a top view of lever *d*. Fig. 11 is a side view of the same lever *d*. Fig. 12 denotes spring *j*. Fig. 13 is a view of stem *c*. Fig. 14 denotes the base-plate of bracket *O*. Fig. 15 shows the stops in wall-bracket *O*. Fig. 16 is the upper

wall-bracket. Fig. 17 is a top view of drop-lever *m*. Fig. 18 denotes the action of the drop-lever *m*.

Fig. 1 is an elevation showing both signals at "danger" to hold the trains coming both ways by showing the red side of both signal-boards and at night by showing the red lights. In this view, *A* is the outer wall of the depot. *B* is a plank or platform extending from and at right angles with wall *A*. *C* is a regular brace to support platform *B*. *D* is the base that supports the signal-boards, lamp, and stems *c c*. *E* is the signal-lamp. *a* is the outer signal-board, and *b* is the inner signal-board. *c c* show the stems to which the signal-boards are attached. *d d* are the levers that turn stems *c c*. *e e* are sockets for stems *c c*, and *f f* are locking-collars. *g* is a set-screw to lock the locking-collars *f f* to stems *c c*. *h h h* are pins in levers *d* and in levers *d'*, to which wires *i* are loosely connected, and which wires are operated by them. *j* is a spring to work against pin *k* of stems *c c* to accelerate the action of stems *c c*. *l* is a bracket to hold rod *q* in its position. *m* is a drop-lever to turn rods *q*, and *n* is a collar attached to rod *q* and tightened thereto by set-screw *p*, and drop-lever *m* is connected by pin *x* in collar *n*. *O* is a wall-bracket to support rod *q*. *r* is a stand, the upper end of which enters the socket at the bottom of lamp *E* and supports the lamp. The lamp has two uncolored or white bull's-eyes or glasses on opposite sides of the lamp at *S*.

Fig. 2 shows arm or plank *B*, platform *D*, and sockets *l*, and the place for lamp *E*, to illustrate more clearly the place of each of stems *c* relative to lamp *E*, the lamp being in the center between stems *c c*.

Fig. 3 is a front view of rod *q* and lever *d'* with pins *h h* and bracket *O*, with lever *m* on the side at "clear track," the dotted line denoting the position of lever *m* when its handle is raised ready to turn to give signal of "danger."

Fig. 4 shows rod *q* and lever *d'* with pins *h h* and bracket *O*, with the handle of lever *m* down in front at "danger."

Fig. 5 denotes the action of levers *d'* and levers *d* and of the signal-boards *a* and *b* with the signal-boards turned to the lamp, their

bull's-eyes being red and being in front of the "clear" lights of the lamp show red lights, denoting "danger."

5 Fig. 6 indicates the action of springs *j* against pins *k* in slots *t* to accelerate the motion of stems *c c*.

Fig. 7 shows a stem *c*, signal-board *b*, bull's-eye *S*, and pin *k*.

Fig. 8 is socket *e* and slot *t*.

10 Fig. 9 is a top or end view of socket *e*, showing slot *t* to receive the point or end of spring *j*.

Fig. 10 shows lever *d* with pin *h* at each end and an opening in the center, and the set-screw, being a top view.

15 Fig. 11 is a side view of lever *d* with pins *h*.

Fig. 12 is spring *j*.

Fig. 13 is a view of stem *c* with pin *k* and showing the notch at its end halved to receive a signal-board.

20 Fig. 14 shows the base-plate of wall-bracket *O*, indicating the place of rod *q* and of slots *u* to receive and hold the handle of drop-lever *m*, and stops *v*.

25 Fig. 15 is a view of bracket *O*, in which *v v* are stops.

Fig. 16 is the upper wall-bracket, in which *l* is the bracket and *w* is an opening in the bracket through which rod *q* acts.

30 Fig. 17 is a top view of drop-lever *m*, in which *x* is a pin through and connecting collar *n* and lever *m*, and *p* is a set-screw, to show how the lever is made.

Fig. 18 is also a view of drop-lever *m*, to show its action.

35 In the operation of this invention levers *m* should be within easy reach of the operator who receives the telegraph orders, so that he can operate them without leaving his seat.

40 Thus as soon as he receives an order he extends his hand and moves lever *m* to execute the order, and then enters and files the order. To illustrate, if both signals show the tracks

45 will be parallel with the railway-tracks and not in front of the glasses in the lamp. If ordered to hold the north-bound train, raise the south handle and turn it a quarter-round to the left and drop it into the front slot *u*,

50 which will revolve the south rod *q* and the south signal-board one-fourth around, which will put signal-board *a* crosswise of the tracks, showing the red side of the signal-board to the south, with its bull's-eye, which is red, in

55 front of the light of the lamp, thus showing a red light. If ordered to hold the south-bound train, do the same with the north handle of drop-lever *m*, which will turn signal-board *b* one-fourth around and show its red

60 side to the north, with its bull's-eye, also red, in front of the north glass of lamp *E* to show red light at night. The signals being suspended by plank or platform *B*, projecting

from wall *A*, the platform of the depot is clear for passengers, baggage, and freight. 65

All parts of this apparatus are cheap, simple, and durable.

What I claim as my invention, and desire to secure by Letters Patent, is—

1. In an apparatus for signaling railway- 70 trains, supported by a bracket formed of a plank, *B*, and a brace, *C*, and a platform *D*, a combination of a perpendicular rod, *q*, having as its base a bracket, *O*, said rod *q*, having a drop-lever, *m*, near its base to turn it, 75 and having a double lever, *d'*, near its upper end and being steadied by a bracket near its upper end, *l*, and being connected by horizontal wires, *i*, to double levers, *d*, and combined with upright stems, *c, c*, said stems 80 having signal-boards, *a*, and *b*, at their upper ends, and having sockets *e*, near their lower part and locking-collars, *f*, at their lower ends, the said signaling-boards having bull's-eyes through them, together with a 85 lamp, *E*, between said stems, *c, c*, so that, when lever *m*, is moved one-quarter around it will revolve rod *q*, and the signal-board one-fourth around and put the signal-board 90 crosswise of the railway-tracks, and showing the danger side of the signal-board, with red lights at night, substantially as and for the purpose specified.

2. In an apparatus for signaling railway- 95 trains, supported by a bracket formed of a plank, *B*, and a brace, *C*, and a platform, *D*, a combination of a perpendicular rod, *q*, having as its base a bracket, *O*, said rod *q* having a drop-lever, *m*, near its base to turn it, 100 and having a double lever, *d'*, near its upper end, and being steadied by a bracket near its upper end, *l*, and being connected with upright stems, *c, c*, said stems having signal- 105 board, *a*, and signal-board *b*, at their upper ends, and having sockets, *e*, near their lower part, and locking-collar, *f*, at their lower ends locked by a set-screw, *g*, the said signal-boards having bull's-eyes through them, *S*. 110 Together with a lamp-stand, *r*, and lamp, *E*, between said stems, *c, c*, the whole is so arranged that, when lever *m*, is moved one- 115 quarter around it will revolve rod *q*, and a signal-board one-fourth around and put the signal-board crosswise of the railway-tracks, showing the danger side of the signal-board with red lights at night. Returning lever *m*, to its first position returns the signal-board to its first position, parallel with the railway-tracks, and showing white lights; substantially as and for the purpose specified. 120

In testimony whereof I affix my signature in presence of two witnesses.

THEODORE W. STUEBER.

Witnesses:

W. H. WARD,
J. B. MORRIS.