



INTERNATIONAL APPLICATION PUBLISHED UNDER THE PATENT COOPERATION TREATY (PCT)

<p>(51) International Patent Classification ⁴ : B29C 67/24, G11C 13/02 B32B 1/10</p>	<p>A1</p>	<p>(11) International Publication Number: WO 89/10255 (43) International Publication Date: 2 November 1989 (02.11.89)</p>
<p>(21) International Application Number: PCT/US89/01560 (22) International Filing Date: 17 April 1989 (17.04.89) (30) Priority data: 183,015 18 April 1988 (18.04.88) US (71) Applicant: 3D SYSTEMS, INC. [US/US]; 26081 Avenue Hall, Valencia, CA 91355 (US). (72) Inventor: SMALLEY, Dennis, Rollette ; 14131 Los Angeles Street, Baldwin Park, CA 91706 (US). (74) Agents: SHALEK, James, H. et al.; 611 West Sixth Street, 34th Floor, Los Angeles, CA 90017 (US). (81) Designated States: JP, KR.</p>		<p>Published With international search report.</p>

(54) Title: REDUCING STEREO LITHOGRAPHIC PART DISTORTION THROUGH ISOLATION OF STRESS

(57) Abstract

An improved stereolithography system for generating a three-dimensional object (30) by creating a cross-sectional pattern of the object to be formed at a selected surface (23) of a fluid medium (22) capable of altering its physical state in response to appropriate synergistic stimulation by impinging radiation, particle bombardment or chemical reaction, using information defining the object which is specially processed to reduce curl, stress, birdnesting and other distortions, the successive adjacent laminae (30a, 30b, 30c), representing corresponding successive adjacent cross-sections of the object, being automatically formed and integrated together to provide a step-wise laminar buildup of the desired object, whereby a three-dimensional object is formed and drawn from a substantially planar surface of the fluid medium during the forming process. Reducing stereolithographic distortion through isolation of stress is described.

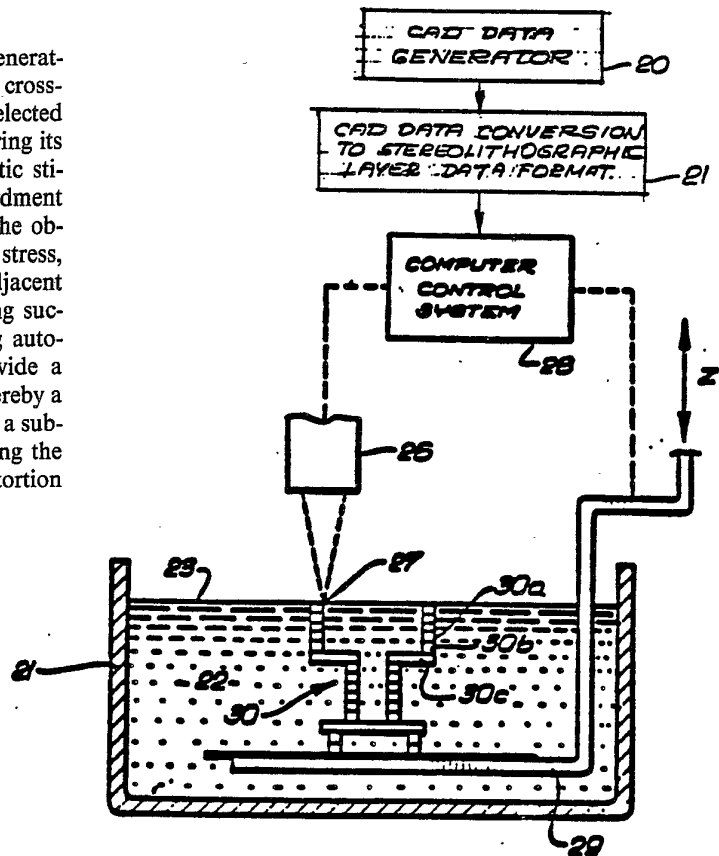

FOR THE PURPOSES OF INFORMATION ONLY

Codes used to identify States party to the PCT on the front pages of pamphlets publishing international applications under the PCT.

AT Austria	FR France	ML Mali
AU Australia	GA Gabon	MR Mauritania
BB Barbados	GB United Kingdom	MW Malawi
BE Belgium	HU Hungary	NL Netherlands
BG Bulgaria	IT Italy	NO Norway
BJ Benin	JP Japan	RO Romania
BR Brazil	KP Democratic People's Republic of Korea	SD Sudan
CF Central African Republic	KR Republic of Korea	SE Sweden
CG Congo	LI Liechtenstein	SN Senegal
CH Switzerland	LK Sri Lanka	SU Soviet Union
CM Cameroon	LU Luxembourg	TD Chad
DE Germany, Federal Republic of	MC Monaco	TG Togo
DK Denmark	MG Madagascar	US United States of America
FI Finland		

DESCRIPTIONReducing Stereolithographic
Part Distortion Through Isolation of Stress1. Cross Reference to Related Applications

This application is related to U.S. Patent Application Serial Nos. 182,823; 182,830; 183,015; 182,801; 183,016; 183,014; and 183,012; filed April 18, 1988, all
5 of which are hereby fully incorporated by reference into this disclosure as though set forth in full herein. Continuations-in-part of U.S. Patent Application Serial Nos. 182,830; 183,016; 183,014; and 183,012 were filed on November 8, 1988, all of which are hereby fully incor-
10 porated by reference into this disclosure as though set forth in full herein. The Serial Nos. for the above-mentioned continuations-in-part are, respectively, 269,801; 268,816; 268,337; 268,907 (all for Ser. No. 182,830); 268,429 (for Ser. No. 183,016); 268,408 (for
15 Ser. No. 183,014); and 268,428 (for Ser. No. 183,012). A continuation of U.S. Patent Application S.N. 269,801 was filed on March 31, 1989, which is hereby fully incorporated by reference into this disclosure as though set forth in full herein. The Lyon & Lyon Docket No. for
20 the above-mentioned continuation application is 186/195.

2. Cross Reference to Attached Appendices

The following appendices are affixed to this application, and are also hereby fully incorporated into this disclosure by reference as though set forth in full
25 herein.

Appendix A: 3D Systems, Inc., SLA-1 Beta Site Stereolithography System Users Manual and Service Manual, November, 1987

Appendix I: 3D Systems, Inc. Stereolithography CAD/CAM Interface Specification,
30 December, 1987

3. Field of the Invention

This invention relates generally to improvements in methods and apparatus for forming three-dimensional objects from a fluid medium and, more particularly, to a new and improved stereolithography system involving the application of enhanced data manipulation and lithographic techniques to production of three-dimensional objects, whereby such objects can be formed more rapidly, reliably, accurately and economically. Specifically, this invention relates to reducing stereo-lithographic distortion of the object by isolating stress.

4. Background of the Invention

It is common practice in the production of plastic parts and the like to first design such a part and then painstakingly produce a prototype of the part, all involving considerable time, effort and expense. The design is then reviewed and, oftentimes, the laborious process is again and again repeated until the design has been optimized. After design optimization, the next step is production. Most production plastic parts are injection molded. Since the design time and tooling costs are very high, plastic parts are usually only practical in high volume production. While other processes are available for the production of plastic parts, including direct machine work, vacuum-forming and direct forming, such methods are typically only cost effective for short run production, and the parts produced are usually inferior in quality to molded parts.

Very sophisticated techniques have been developed in the past for generating three-dimensional objects within a fluid medium which is selectively cured by beams of radiation brought to selective focus at prescribed intersection points within the three-dimensional volume of the fluid medium. Typical of such three-dimensional systems are those described in U.S. Pat. Nos. 4,041,476; 4,078,229; 4,238,840 and 4,288,861. All of these systems

rely upon the buildup of synergistic energization at selected points deep within the fluid volume, to the exclusion of all other points in the fluid volume. Unfortunately, however, such three-dimensional forming systems face a number of problems with regard to resolution and exposure control. The loss of radiation intensity and image forming resolution of the focused spots as the intersections move deeper into the fluid medium create rather obvious complex control situations. Absorption, diffusion, dispersion and diffraction all contribute to the difficulties of working deep within the fluid medium on an economical and reliable basis.

In recent years, "stereolithography" systems, such as those described in U.S. Pat. No. 4,575,330 entitled "Apparatus For Production Of Three-Dimensional Objects By Stereolithography", which is hereby incorporated by reference as though set forth in full herein, have come into use. Basically, stereolithography is a method for automatically building complex plastic parts by successively printing cross-sections of photopolymer (such as liquid plastic) on top of each other until all of the thin layers are joined together to form a whole part. With this technology, the parts are literally grown in a vat of liquid plastic. This method of fabrication is extremely powerful for quickly reducing design ideas to physical form and for making prototypes.

Photocurable polymers change from liquid to solid in the presence of light and their photospeed with ultraviolet light (UV) is fast enough to make them practical model building materials. The material that is not polymerized when a part is made is still usable and remains in the vat as successive parts are made. An ultraviolet laser generates a small intense spot of UV. This spot is moved across the liquid surface with a galvanometer mirror XY scanner. The scanner is driven by computer generated vectors or the like. Precise complex patterns can be rapidly produced with this technique.

The laser scanner, the photopolymer vat and the elevator, along with a controlling computer, combine together to form a stereolithography apparatus, referred to as an "SLA". An SLA is programmed to automatically
5 make a plastic part by drawing a cross section at a time, and building it up layer by layer.

Stereolithography represents an unprecedented way to quickly make complex or simple parts without tooling. Since this technology depends on using a computer to
10 generate its cross sectional patterns, there is a natural data link to CAD/CAM. However, such systems have encountered difficulties relating to shrinkage, curl and other distortions, as well as resolution, accuracy and difficulties in producing certain object shapes.

15 Objects built using stereolithography have a tendency to distort from their CAD designed dimensions. This distortion may or may not appear in a specific object, based on how much stress is developed by the specific cure parameters and on the object's ability to withstand
20 stress. The stress that causes distortion develops when material that is being converted from liquid to solid comes into contact with and bonds to previously cured material. When material is converted from liquid to solid it shrinks slightly. This shrinking causes stress and has
25 two primary physical causes: 1) density of the liquid is less than that of the solid plastic; and 2) the chemical reaction that causes the change of state is strongly exothermic causing the curing material to thermally expand and contract. This stress causes a distortion known as
30 curl, which is described in more detail in S.N. 182,823.

Certain sections of an object will be able to resist stresses without any apparent warp (stress is at a tolerable level). On the other hand, other sections may distort considerably as the stress and structural strength
35 balance each other. Since stress is caused by contact between curing material and cured material it can be propagated along the entire length of contact between the

curing line and cured material. Most contact of curing to cured material occurs from one layer to the next as opposed to along a single layer. This implies most distortions will be vertical in nature as opposed to horizontal. Therefore, there has been a need for a technique to reduce vertical distortions.

"Birdnesting" is a phenomena that can occur on parts that require down-facing, near-flat skin by the stereolithographic apparatus' SLICE program. Commercial implementations of SLICE programs for converting a CAD/CAM representation of a part into vectors is described in S.N. 182,830, its CIP, S.N. 269,801, and its continuation, Lyon & Lyon Dkt. No. 186/195. The different vector types, including near-flat skin, cross-hatch, and boundary vectors are also discussed in these applications. Areas that require down-facing, near-flat skin are problematic because their boundary vectors do not have any support when they are drawn. By the time cross-hatch is finally drawn, to secure the boundaries, the boundary vectors may have moved away from their proper positions and, therefore, may not be secured at particular locations. These unsecured boundaries can move up and down and give a rough surface finish to the object, similar to a bird's nest.

Hence, workers in the art have recognized the need for a solution to the aforescribed problems encountered in stereolithographics, and there continues to be a long existing need in the design and production arts for the capability of rapidly and reliably moving from the design stage to the prototype stage and to ultimate production, particularly moving directly from the computer designs for such plastic parts to virtually immediate prototypes and the facility for large scale production on an economical and automatic basis.

Accordingly, those concerned with the development and production of three-dimensional plastic objects and the like have long recognized the desirability for further

improvement in more rapid, reliable, economical and automatic means which would facilitate quickly moving from a design stage to the prototype stage and to production, while avoiding the problems of stress, distortion and poor part finish. The present invention clearly fulfills all of these needs.

Summary of the Invention

Briefly, and in general terms, the present invention provides a new and improved stereolithography system for generating a three-dimensional object by forming successive, adjacent, cross-sectional laminae of that object at the face of a fluid medium capable of altering its physical state in response to appropriate synergistic stimulation, information defining the object being specially tailored to reduce curl, stress, birdnesting and other distortions, the successive laminae being automatically integrated as they are formed to define the desired three-dimensional object.

In accordance with the invention, distortion is reduced by isolating sections of an object so that stress cannot be transmitted from one section to another. This isolation technique (Smalleys) limits the distortion in a given section to that which can be caused by the stress developed within that section only, not from other sections.

Layer sections prone to curling may be isolated by designing small holes or gaps at stress points in the CAD design of the part. These gaps, called "Smalleys", block propagation of stresses along layer sections. This reduces the stresses acting on a part to only those created within the section. If the Smalleys are properly designed, these localized stresses will be below the threshold value which would curl the layer section.

Smalleys are also used to reduce birdnesting. The width of Smalleys, for this application, is generally less than cure width, so that after curing they are completely

filled in and so no structural integrity is lost through their use. Smalleys are placed periodically in regions of down-facing near-flat triangles with heights appropriate to extend vertically through the near-flat triangles. The placement of Smalleys is based on several factors that affect the likelihood of having birdnesting problems: the radius of curvature of the boundaries, the length of near-flat zones, the likelihood of boundaries moving, etc. Smalleys do not need to penetrate completely through a wall, as they do in their other application, but they do need to penetrate deep enough to insure a contact point with the boundaries on the previous layer.

The present invention harnesses the principles of computer generated graphics in combination with stereolithography, i.e., the application of lithographic techniques to the production of three-dimensional objects, to simultaneously execute computer aided design (CAD) and computer aided manufacturing (CAM) in producing three-dimensional objects directly from computer instructions. The invention can be applied for the purposes of sculpturing models and prototypes in a design phase of product development, or as a manufacturing system, or even as a pure art form.

"Stereolithography" is a method and apparatus for making solid objects by successively "printing" thin layers of a curable material, e.g., a UV curable material, one on top of the other. A programmed movable spot beam of UV light shining on a surface or layer of UV curable liquid is used to form a solid cross-section of the object at the surface of the liquid. The object is then moved, in a programmed manner, away from the liquid surface by the thickness of one layer, and the next cross-section is then formed and adhered to the immediately preceding layer defining the object. This process is continued until the entire object is formed.

Essentially all types of object forms can be created with the technique of the present invention. Complex

forms are more easily created by using the functions of a computer to help generate the programmed commands and to then send the program signals to the stereolithographic object forming subsystem.

5 Of course, it will be appreciated that other forms of appropriate synergistic stimulation for a curable fluid medium, such as particle bombardment (electron beams and the like) chemical reactions by spraying materials through a mask or by ink jets, or impinging radiation other than
10 ultraviolet light, may be used in the practice of the invention without departing from the spirit and scope of the invention.

By way of example, in the practice of the present invention, a body of a fluid medium capable of
15 solidification in response to prescribed stimulation is first appropriately contained in any suitable vessel to define a designated working surface of the fluid medium at which successive cross-sectional laminae can be generated. Thereafter, an appropriate form of synergistic
20 stimulation, such as a spot of UV light or the like, is applied as a graphic pattern at the specified working surface of the fluid medium to form thin, solid, individual layers at the surface, each layer representing an adjacent cross-section of the three-dimensional object
25 to be produced. In accordance with the invention, information defining the object is specially processed to reduce curl and distortion, and increase resolution, strength, accuracy, speed and economy of reproduction.

Superposition of successive adjacent layers on each
30 other is automatically accomplished, as they are formed, to integrate the layers and define the desired three-dimensional object. In this regard, as the fluid medium cures and solid material forms as a thin lamina at the working surface, a suitable platform to which the
35 first lamina is secured is moved away from the working surface in a programmed manner by any appropriate actuator, typically all under the control of a micro-

computer or the like. In this way, the solid material that was initially formed at the working surface is moved away from that surface and new liquid flows into the working surface position. A portion of this new liquid is, in turn, converted to solid material by the programmed UV light spot to define a new lamina, and this new lamina adhesively connects to the material adjacent to it, i.e., the immediately preceding lamina. This process continues until the entire three-dimensional object has been formed.

10 The formed object is then removed from the container and the apparatus is ready to produce another object, either identical to the first object or an entirely new object generated by a computer or the like.

The data base of a CAD system can take several forms.

15 One form consists of representing the surface of an object as a mesh of polygons, typically triangles. These triangles completely form the inner and outer surfaces of the object. This CAD representation also includes a unit length normal vector for each triangle. The normal points away from the solid which the triangle is bounding and indicates slope. Means are provided for processing CAD data, which may be in the form of "PHIGS" or the like, into layer-by-layer vector data that can be used for forming models through stereolithography. Such information

20 may ultimately be converted to raster scan output data or the like.

As previously indicated, stereolithography is a three-dimensional printing process which uses a moving laser beam to build parts by solidifying successive layers of liquid plastic. This method enables a designer to create a design on a CAD system, applying the concepts of this invention, to reduce curl, stress, birdnesting and other distortions and build an accurate plastic model in a few hours. By way of example, a stereolithographic process may include the following steps.

30

35

First, the solid model is designed in the normal way on the CAD system, without specific reference to the stereolithographic process.

Model preparation for stereolithography involves
5 selecting the optimum orientation, adding supports, building in appropriate stress relief, and selecting the operating parameters of the stereolithography system. The optimum orientation will (1) enable the object to drain,
(2) have the least number of unsupported surfaces, (3)
10 optimize important surfaces, and (4) enable the object to fit in the resin vat. Supports must be added to secure unattached sections and for other purposes, and a CAD library of supports can be prepared for this purpose. The stereolithography operating parameters include selection
15 of the model scale and layer (slice) thickness.

The surface of the solid model is then divided into triangles, typically "PHIGS". A triangle is the least complex polygon for vector calculations. The more triangles formed, the better the surface resolution and
20 hence, the more accurate the formed object with respect to the CAD design.

Data points representing the triangle coordinates and normals thereto are then transmitted typically as PHIGS, to the stereolithographic system via appropriate network
25 communication such as ETHERNET. The software of the stereolithographic system then slices the triangular sections horizontally (XY plane) at the selected layer thickness.

The stereolithographic unit (SLA) next calculates the
30 section boundary, hatch, and horizontal surface (skin) vectors. Hatch vectors consist of cross-hatching between the boundary vectors. Several "styles" or slicing formats are available. Skin vectors, which are traced at high speed and with a large overlap, form the outside
35 horizontal surfaces of the object. Interior horizontal areas, those within top and bottom skins, are not filled in other than by cross-hatch vectors.

The SLA then forms the object one horizontal layer at a time by moving the ultraviolet beam of a helium-cadmium laser or the like across the surface of a photocurable resin and solidifying the liquid where it strikes.

5 Absorption in the resin prevents the laser light from penetrating deeply and allows a thin layer to be formed. Each layer is comprised of vectors which are typically drawn in the following order: border, hatch, and surface.

The first layer that is drawn by the SLA adheres to
10 a horizontal platform located just below the liquid surface. This platform is attached to an elevator which then lowers the elevator under computer control. After drawing a layer, the platform dips a short distance, such as several millimeters into the liquid to coat the
15 previous cured layer with fresh liquid, then rises up a smaller distance leaving a thin film of liquid from which the second layer will be formed. After a pause to allow the liquid surface to flatten out, the next layer is drawn. Since the resin has adhesive properties, the second
20 layer becomes firmly attached to the first. This process is repeated until all the layers have been drawn and the entire three-dimensional object is formed. Normally, the bottom 0.25 inch or so of the object is a support structure on which the desired part is built. Resin that
25 has not been exposed to light remains in the vat to be used for the next part. There is very little waste of material.

Post processing typically involves draining the formed object to remove excess resin, ultraviolet or heat
30 curing to complete polymerization, and removing supports. Additional processing, including sanding and assembly into working models, may also be performed.

The new and improved stereolithographic system of the present invention has many advantages over currently used
35 apparatus for producing plastic objects. The methods and apparatus of the present invention avoid the need of producing design layouts and drawings, and of producing

tooling drawings and tooling. The designer can work directly with the computer and a stereolithographic device, and when he is satisfied with the design as displayed on the output screen of the computer, he can
5 fabricate a part for direct examination. If the design has to be modified, it can be easily done through the computer, and then another part can be made to verify that the change was correct. If the design calls for several parts with interacting design parameters, the method of
10 the invention becomes even more useful because of all of the part designs can be quickly changed and made again so that the total assembly can be made and examined, repeatedly if necessary. Moreover, the data manipulation techniques of the present invention enable production of
15 objects with reduced stress, curl and distortion, and increased resolution, strength accuracy, speed and economy of production, even for difficult and complex object shapes.

After the design is complete, part production can
20 begin immediately, so that the weeks and months between design and production are avoided. Stereolithography is particularly useful for short run production because the need for tooling is eliminated and production set-up time is minimal. Likewise, design changes and custom parts are
25 easily provided using the technique. Because of the ease of making parts, stereolithography can allow plastic parts to be used in many places where metal or other material parts are now used. Moreover, it allows plastic models of objects to be quickly and economically provided, prior to
30 the decision to make more expensive metal or other material parts.

Hence, the new and improved stereolithographic methods and apparatus of the present invention satisfy a long existing need for an improved CAD and CAM system
35 capable of rapidly, reliably, accurately and economically designing and fabricating three-dimensional parts and the

like with reduced stress, curl, birdnesting or other distortions.

The above and other objects and advantages of this invention will be apparent from the following more
5 detailed description when taken in conjunction with the accompanying drawings of illustrative embodiments.

Brief Description of the Drawings

FIG. 1 is an overall block diagram of a stereolithography system for the practice of the present
10 invention;

FIGS. 2 and 3 are flow charts illustrating the basic concepts employed in practicing the method of stereolithography of the present invention;

FIG. 4 is a combined block diagram, schematic and
15 elevational section view of a system suitable for practicing the invention;

FIG. 5 is an elevational sectional view of a second embodiment of a stereolithography system for the practice of the invention;

20 FIG. 6 is a software architecture flowchart depicting in greater detail the overall data flow, data manipulation and data management in a stereolithography system;

FIG. 7 illustrates perspectives of a distorted part and one with distortion minimized through the use of
25 "Smalleys."

FIG. 8 schematically depicts the application of Smalleys to a typical curling situation;

FIG. 9 illustrates, in section, the application of Smalleys for inhibiting curl in thick interior structures;

30 FIG. 10 is a side view of a CAD designed cone without Smalleys;

FIG. 11 and 12 are views of the sliced CAD designed cone and what it might look like after building;

35 FIG. 13 is a top view of a CAD designed cone showing possible locations in the XY plane where Smalleys might be inserted;

FIG. 14 is a side view of a sliced CAD designed cone with Smalleys and what it might look like after building;

FIG. 15 is a top view of two cross-sections of a cone with no Smalleys;

5 FIG. 16 is a top view of two cross-sections of a cone with the second layer only showing the boundary vectors drawn;

FIG. 17 is a top view of two cross-sections of a cone with the second layer showing the boundary vectors not making contact with cross-hatch in a particular location;

10 FIG. 18 is a top view of two cross-sections of a cone with Smalleys;

FIG. 19 is a top view of a two cross-sections of a cone with Smalleys with the second layer only showing the boundary vectors drawn; and

15 FIG. 20 is a top view of two cross-sections of a cone with Smalleys with the second layer showing the boundary vectors making contact with cross-hatch everywhere.

Detailed Description of the Preferred Embodiment

20 In accordance with the invention, distortion is reduced by isolating sections of an object so that stress cannot be transmitted from one section to another. This isolation technique (Smalleys) limits the distortion in a given section to that which can be caused by the stress developed within that section only, not from other sections.

Referring now to the drawings, and particularly to FIG. 1 thereof, there is shown a block diagram of an overall stereolithography system suitable for practicing the present invention. A CAD generator 2 and appropriate interface 3 provide a data description of the object to be formed, typically in PHIGS format, via network communication such as ETHERNET or the like to an interface computer 4 where the object data is manipulated to optimize the data and provide output vectors which reduce stress, curl and distortion, and increase resolution,

strength, accuracy, speed and economy of reproduction, even for rather difficult and complex object shapes. The interface computer 4 generates layer data by slicing, varying layer thickness, rounding polygon vertices, 5 filling, generating flat skins, near-flat skins, up-facing and down-facing skins, scaling, cross-hatching, offsetting vectors and ordering of vectors. More details about the vector types are available in S.N. 182,830, its CIP, S.N. 269,801 and its continuation, Lyon & Lyon Docket No. 10 186/195. Briefly, boundary vectors are used to trace the outline of each cross-section, hatch vectors are used to provide internal structure between the boundary vectors, and skin vectors are used to define the outer surfaces of the object. They are traced in the following order: 15 boundary, hatch, skin.

The vector data and parameters from the computer 4 are directed to a controller subsystem 5 for operating the system stereolithography laser, mirrors, elevator and the like.

20 FIGS. 2 and 3 are flow charts illustrating the basic system of the present invention for generating three-dimensional objects by means of stereolithography.

Many liquid state chemicals are known which can be induced to change to solid state polymer plastic by 25 irradiation with ultraviolet light (UV) or other forms of synergistic stimulation such as electron beams, visible or invisible light, reactive chemicals applied by ink jet or via a suitable mask. UV curable chemicals are currently used as ink for high speed printing, in processes of 30 coating or paper and other materials, as adhesives, and in other specialty areas.

Lithography is the art of reproducing graphic objects, using various techniques. Modern examples include photographic reproduction, xerography, and 35 microlithography, as is used in the production of microelectronics. Computer generated graphics displayed on a plotter or a cathode ray tube are also forms of

lithography, where the image is a picture of a computer coded object.

Computer aided design (CAD) and computer aided manufacturing (CAM) are techniques that apply the abilities of computers to the processes of designing and manufacturing. A typical example of CAD is in the area of electronic printed circuit design, where a computer and plotter draw the design of a printed circuit board, given the design parameters as computer data input. A typical example of CAM is a numerically controlled milling machine, where a computer and a milling machine produce metal parts, given the proper programming instructions. Both CAD and CAM are important and are rapidly growing technologies.

A prime object of the present invention is to harness the principles of computer generated graphics, combined with UV curable plastic and the like, to simultaneously execute CAD and CAM, and to produce three-dimensional objects directly from computer instructions. This invention, referred to as stereolithography, can be used to sculpture models and prototypes in a design phase of product development, or as a manufacturing device, or even as an art form. The present invention enhances the developments in stereolithography set forth in U.S. Patent No. 4,575,330, issued March 11, 1986, to Charles W. Hull, one of the inventors herein.

Referring now more specifically to FIG. 2 of the drawings, the stereolithographic method is broadly outlined. Step 8 calls for generation of CAD or other data, typically in digital form, representing a three-dimensional object to be formed by the system. This CAD data usually defines surfaces in polygon format, triangles and normals perpendicular to the planes of those triangles, e.g., for slope indications, being presently preferred, and in a presently preferred embodiment of the invention conforms to the Programmer's Hierarchical Interactive Graphics System (PHIGS) now adapted as an ANSI

standard. This standard is described, by way of example in the publication "Understanding PHIGS", published by Template, Megatek Corp., San Diego, California, which is hereby fully incorporated into this disclosure by
5 reference as though set forth in full herein.

In Step 9, the PHIGS data or its equivalent is converted, in accordance with the invention, by a unique conversion system to a modified data base for driving the stereolithography output system in forming
10 three-dimensional objects. In this regard, information defining the object is specially processed to reduce stress, curl and distortion, and increase resolution, strength and accuracy of reproduction.

Step 10 in FIG. 2 calls for the generation of
15 individual solid laminae representing cross-sections of a three-dimensional object to be formed. Step 11 combines the successively formed adjacent laminae to form the desired three-dimensional object which has been programmed into the system for selective curing.

Hence, the stereolithographic system of the present
20 invention generates three-dimensional objects by creating a cross-sectional pattern of the object to be formed at a selected surface of a fluid medium, e.g., a UV curable liquid or the like, capable of altering its physical state
25 in response to appropriate synergistic stimulation such as impinging radiation, electron beam or other particle bombardment, or applied chemicals (as by ink jet or spraying over a mask adjacent the fluid surface), successive adjacent laminae, representing corresponding
30 successive adjacent cross-sections of the object, being automatically formed and integrated together to provide a step-wise laminar or thin layer buildup of the object, whereby a three-dimensional object is formed and drawn from a substantially planar or sheet-like surface of the
35 fluid medium during the forming process.

The aforescribed technique illustrated in FIG. 2 is more specifically outlined in the flowchart of FIG. 3,

where again Step 8 calls for generation of CAD or other data, typically in digital form, representing a three-dimensional object to be formed by the system. Again, in Step 9, the PHIGS data is converted by a unique
5 conversion system to a modified data base for driving the stereolithography output system in forming three-dimensional objects. Step 12 calls for containing a fluid medium capable of solidification in response to prescribed reactive stimulation. Step 13 calls for
10 application of that stimulation as a graphic pattern, in response to data output from the computer 4 in Fig. 1, at a designated fluid surface to form thin, solid, individual layers at that surface, each layer representing an adjacent cross-section of a three-dimensional object to be
15 produced. In the practical application of the invention, each lamina will be a thin lamina, but thick enough to be adequately cohesive in forming the cross-section and adhering to the adjacent laminae defining other cross-sections of the object being formed.

20 Step 14 in FIG. 3 calls for superimposing successive adjacent layers or laminae on each other as they are formed, to integrate the various layers and define the desired three-dimensional object. In the normal practice of the invention, as the fluid medium cures and solid
25 material forms to define one lamina, that lamina is moved away from the working surface of the fluid medium and the next lamina is formed in the new liquid which replaces the previously formed lamina, so that each successive lamina is superimposed and integral with (by virtue of the
30 natural adhesive properties of the cured fluid medium) all of the other cross-sectional laminae. Of course, as previously indicated, the present invention also deals with the problems posed in transitioning between vertical and horizontal.

35 The process of producing such cross-sectional laminae is repeated over and over again until the entire three-dimensional object has been formed. The object is then

removed and the system is ready to produce another object which may be identical to the previous object or may be an entirely new object formed by changing the program controlling the stereolithographic system.

5 FIGS. 4-5 of the drawings illustrate various apparatus suitable for implementing the stereolithographic methods illustrated and described by the systems and flow charts of FIGS. 1-3.

As previously indicated, "Stereolithography" is a
10 method and apparatus for making solid objects by successively "printing" thin layers of a curable material, e.g., a UV curable material, one on top of the other. A programmable movable spot beam of UV light shining on a surface or layer of UV curable liquid is used to form a
15 solid cross-section of the object at the surface of the liquid. The object is then moved, in a programmed manner, away from the liquid surface by the thickness of one layer and the next cross-section is then formed and adhered to the immediately preceding layer defining the object. This
20 process is continued until the entire object is formed.

Essentially all types of object forms can be created with the technique of the present invention. Complex forms are more easily created by using the functions of a computer to help generate the programmed commands and to
25 then send the program signals to the stereolithographic object forming subsystem.

The data base of a CAD system can take several forms. One form, as previously indicated, consists of representing the surface of an object as a mesh of
30 triangles (PHIGS). These triangles completely form the inner and outer surfaces of the object. This CAD representation also includes a unit length normal vector for each triangle. The normal points away from the solid which the triangle is bounding. This invention provides
35 a means of processing such CAD data into the layer-by-layer vector data that is necessary for forming objects through stereolithography.

For stereolithography to successfully work, there must be good adhesion from one layer to the next. Hence, plastic from one layer must overlay plastic that was formed when the previous layer was built. In building
5 models that are made of vertical segments, plastic that is formed on one layer will fall exactly on previously formed plastic from the preceding layer, and thereby provide good adhesion. As one starts to make a transition from vertical to horizontal features, using finite jumps in
10 layer thickness, a point will eventually be reached where the plastic formed on one layer does not make contact with the plastic formed on the previous layer, and this causes severe adhesion problems. Horizontal surfaces themselves do not present adhesion problems because by being
15 horizontal the whole section is built on one layer with side-to-side adhesion maintaining structural integrity. Therefore, means are provided for insuring adhesion between layers when making transitions from vertical to horizontal or horizontal to vertical sections, as well as
20 providing a way to completely bound a surface, and ways to reduce or eliminate stress and strain in formed parts.

A presently preferred embodiment of a new and improved stereolithographic system is shown in elevational cross-section in FIG. 4. A container 21 is filled with a
25 UV curable liquid 22 or the like, to provide a designated working surface 23. A programmable source of ultraviolet light 26 or the like produces a spot of ultraviolet light 27 in the plane of surface 23. The spot 27 is movable across the surface 23 by the motion of mirrors or other
30 optical or mechanical elements (not shown in Fig. 4) used with the light source 26. The position of the spot 27 on surface 23 is controlled by a computer control system 28. As previously indicated, the system 28 may be under control of CAD data produced by a generator 20 in a CAD
35 design system or the like and directed in PHIGS format or its equivalent to a computerized conversion system 25 where information defining the object is specially

processed to reduce stress, curl and distortion, and increase resolution, strength and accuracy of reproduction.

5 A movable elevator platform 29 inside container 21 can be moved up and down selectively, the position of the platform being controlled by the system 28. As the device operates, it produces a three-dimensional object 30 by step-wise buildup of integrated laminae such as 30a, 30b, 30c.

10 The surface of the UV curable liquid 22 is maintained at a constant level in the container 21, and the spot of UV light 27, or other suitable form of reactive stimulation, of sufficient intensity to cure the liquid and convert it to a solid material is moved across the
15 working surface 23 in a programmed manner. As the liquid 22 cures and solid material forms, the elevator platform 29 that was initially just below surface 23 is moved down from the surface in a programmed manner by any suitable actuator. In this way, the solid material that was
20 initially formed is taken below surface 23 and new liquid 22 flows across the surface 23. A portion of this new liquid is, in turn, converted to solid material by the programmed UV light spot 27, and the new material adhesively connects to the material below it. This
25 process is continued until the entire three-dimensional object 30 is formed. The object 30 is then removed from the container 21, and the apparatus is ready to produce another object. Another object can then be produced, or some new object can be made by changing the program in the
30 computer 28.

The curable liquid 22, e.g., UV curable liquid, must have several important properties. (A) It must cure fast enough with the available UV light source to allow practical object formation times. (B) It must be
35 adhesive, so that successive layers will adhere to each other. (C) Its viscosity must be low enough so that fresh liquid material will quickly flow across the surface when

the elevator moves the object. (D) It should absorb UV so that the film formed will be reasonably thin. (E) It must be reasonably insoluble in that same solvent in the solid state, so that the object can be washed free of the UV
5 cure liquid and partially cured liquid after the object has been formed. (F) It should be as non-toxic and non-irritating as possible.

The cured material must also have desirable properties once it is in the solid state. These
10 properties depend on the application involved, as in the conventional use of other plastic materials. Such parameters as color, texture, strength, electrical properties, flammability, and flexibility are among the properties to be considered. In addition, the cost of the
15 material will be important in many cases.

The UV curable material used in the presently preferred embodiment of a working stereolithograph (e.g., FIG. 3) is DeSoto SLR 800 stereolithography resin, made by DeSoto, Inc. of Des Plains, Illinois.

20 The light source 26 produces the spot 27 of UV light small enough to allow the desired object detail to be formed, and intense enough to cure the UV curable liquid being used quickly enough to be practical. The source 26 is arranged so it can be programmed to be turned off and
25 on, and to move, such that the focused spot 27 moves across the surface 23 of the liquid 22. Thus, as the spot 27 moves, it cures the liquid 22 into a solid, and "draws" a solid pattern on the surface in much the same way a chart recorder or plotter uses a pen to draw a pattern on
30 paper.

The light source 26 for the presently preferred embodiment of a stereolithography is typically a helium-cadmium ultraviolet laser such as the Model 4240-N HeCd Multimode Laser, made by Liconix of Sunnyvale,
35 California.

In the system of FIG. 4, means may be provided to keep the surface 23 at a constant level and to replenish

this material after an object has been removed, so that the focus spot 27 will remain sharply in focus on a fixed focus plane, thus insuring maximum resolution in forming a high layer along the working surface. In this regard,
5 it is desired to shape the focal point to provide a region of high intensity right at the working surface 23, rapidly diverging to low intensity and thereby limiting the depth of the curing process to provide the thinnest appropriate cross-sectional laminae for the object being formed.

10 The elevator platform 29 is used to support and hold the object 30 being formed, and to move it up and down as required. Typically, after a layer is formed, the object 30 is moved beyond the level of the next layer to allow the liquid 22 to flow into the momentary void at surface
15 23 left where the solid was formed, and then it is moved back to the correct level for the next layer. The requirements for the elevator platform 29 are that it can be moved in a programmed fashion at appropriate speeds, with adequate precision, and that it is powerful enough to
20 handle the weight of the object 30 being formed. In addition, a manual fine adjustment of the elevator platform position is useful during the set-up phase and when the object is being removed.

The elevator platform 29 can be mechanical,
25 pneumatic, hydraulic, or electrical and may also be optical or electronic feedback to precisely control its position. The elevator platform 29 is typically fabricated of either glass or aluminum, but any material to which the cured plastic material will adhere is
30 suitable.

A computer controlled pump (not shown) may be used to maintain a constant level of the liquid 22 at the working surface 23. Appropriate level detection system and feedback networks, well known in the art, can be used to
35 drive a fluid pump or a liquid displacement device, such as a solid rod (not shown) which is moved out of the fluid medium as the elevator platform is moved further into the

fluid medium, to offset changes in fluid volume and maintain constant fluid level at the surface 23. Alternatively, the source 26 can be moved relative to the sensed level 23 and automatically maintain sharp focus at the working surface 23. All of these alternatives can be readily achieved by appropriate data operating in conjunction with the computer control system 28.

Fig. 6 of the drawings illustrates the overall software architecture of a stereolithography system in which the present invention may be practiced.

As an overview, the portion of our processing referred to as "SLICE" takes in the object that you want to build, together with any scaffolding or supports that are necessary to make it more buildable. These supports are typically generated by the user's CAD. The first thing SLICE does is to find the outlines of the object and its supports.

SLICE defines each microsection or layer one at a time under certain specified controlling styles. SLICE produces a boundary to the solid portion of the object. If, for instance, the object is hollow, there will be an outside surface and an inside one. This outline then is the primary information. The SLICE program then takes that outline or series of outlines and says, but if you build an outside skin and an inside skin they won't join to one another, you'll have liquid between them. It will collapse. So let us turn this into a real product, a real part by putting in cross-hatching between the surfaces or solidifying everything in between or adding skins where it's so gentle a slope that one layer wouldn't join on top of the next, remembering past history or slope of the triangles (PHIGS) whichever way you look at it. SLICE does all those things and uses some lookup tables of the chemical characteristics of the photopolymer, how powerful the laser is, and related parameters to indicate how long to expose each of the output vectors used to operate the system. That output consists of identifiable groups. One

group consists of the boundaries or outlines. Another group consists of cross-hatches. A third group consists of skins and there are subgroups of those, upward facing skins, downward facing skins which have to be treated slightly differently. These subgroups are all tracked differently because they may get slightly different treatment, in the process the output data is then appropriately managed to form the desired object and supports. More detail about the different vector types produced by SLICE are contained in S.N. 182,830, its CIP, S.N. 269,801, and its continuation Lyon & Lyon Docket No. 186/195.

After the three-dimensional object 30 has been formed, the elevator platform 29 is raised and the object is removed from the platform for post processing.

In addition, there may be several containers 21 used in the practice of the invention, each container having a different type of curable material that can be automatically selected by the stereolithographic system. In this regard, the various materials might provide plastics of different colors, or have both insulating and conducting material available for the various layers of electronic products.

As will be apparent from FIG. 5 of the drawings, there is shown an alternate configuration of a stereolithograph wherein the UV curable liquid 22 or the like floats on a heavier UV transparent liquid 32 which is non-miscible and non-wetting with the curable liquid 22. By way of example, ethylene glycol or heavy water are suitable for the intermediate liquid layer 32. In the system of FIG. 4, the three-dimensional object 30 is pulled up from the liquid 22, rather than down and further into the liquid medium, as shown in the system of FIG. 3.

The UV light source 26 in FIG. 5 focuses the spot 27 at the interface between the liquid 22 and the non-miscible intermediate liquid layer 32, the UV radiation passing through a suitable UV transparent window

33, of quartz or the like, supported at the bottom of the container 21. The curable liquid 22 is provided in a very thin layer over the non-miscible layer 32 and thereby has the advantage of limiting layer thickness directly rather than relying solely upon adsorption and the like to limit the depth of curing since ideally an ultra-thin lamina is to be provided. Hence, the region of formation will be more sharply defined and some surfaces will be formed smoother with the system of FIG. 5 than with that of FIG. 4. In addition a smaller volume of UV curable liquid 22 is required, and the substitution of one curable material for another is easier.

A commercial stereolithography system will have additional components and subsystems besides those previously shown in connection with the schematically depicted systems of FIGS. 1-5. For example, the commercial system would also have a frame and housing, and a control panel. It should have means to shield the operator from excess UV and visible light, and it may also have means to allow viewing of the object 30 while it is being formed. Commercial units will provide safety means for controlling ozone and noxious fumes, as well as conventional high voltage safety protection and interlocks. Such commercial units will also have means to effectively shield the sensitive electronics from electronic noise sources.

The present invention addresses some additional problems encountered in the practice of stereolithography. Each new layer of a stereolithographic part tends to pull upward on the next lower layer while it is being formed. This is a direct result of stresses created by the curing layer as the liquid is converted to solid. This action may cause both layers to curl upward, dependent on the geometry of the layers and whether or not the lower layer is securely held in place either by supports or by strong adhesion to the next lower layer. Certain of these shapes are more susceptible to curling, and may require special

design features known as Smalleys in order to inhibit or minimize curl.

Stresses are created in the curing layer in two ways. First, the liquid plastic used in stereolithography is less dense than as a solid. This means that the solid will take up less volume and will tend to pull on the lower layer as it shrinks. Second, the plastic expands when it is heated by the polymerization process and subsequently contracts as it cools. Since the new layer formed by the laser is firmly bonded to the lower layer, it tends to pull upward on the lower layer as it cools.

There are several methods available to ensure that stresses are maintained at a level that will not cause curling. One is the use of resins whose properties minimize thermal expansion and contraction. These resins are in development, but may still not solve the curling problem for all applications.

The second method, in accordance with this invention, is to isolate sections of a part so that the stresses cannot propagate over large distances and will not be transmitted beyond certain stress points in the part.

Layer sections prone to curling may be isolated by designing small holes or gaps at stress points in the CAD design of the part. These gaps, called "Smalleys", block propagation of stresses along layer sections. This reduces the stresses acting on a part to only those created within the section. If the Smalleys are properly designed, these localized stresses will be below the threshold value which would curl the layer section.

Hence, Smalleys inhibit the transmission of stress from one section to another. They also serve to limit the stress to an amount that will minimize distortion in a given section (by limiting the stress before it gets large enough to cause distortion). Smalleys are generally designed on the CAD to be 15 to 30 mils wide (depending on the expected cure width). They are also generally designed 40 to 80 mils tall (depending on the strength of

the material and part geometry). When the material is cured, the Smalleys narrow by a full cure width of material. Hence, the right choice of design width can yield Smalleys that are almost completely hidden after
5 post curing. It must be noted, however, that Smalleys must be designed so that when boundary vectors are drawn the Smalleys do not completely close. This is typically accomplished during the CAD design of the object. When we
10 implement the ability to offset vectors to account for finite cure width of material, the width of design of Smalleys can be reduced to a few mils.

Note that in the above discussion, the Smalleys will narrow by a full cure width of material only if beam width compensation is not being performed when the material
15 around the Smalleys is being cured. Beam width compensation is described in more detail in S.N. 182,830, its CIP, S.N. 269,801, and its continuation, Lyon & Lyon Docket No. 186/195. Briefly, beam width compensation moves the border vectors for a cross section inwards by
20 one half the beam width, so that cross section, once cured, will more accurately represent the object.

A floating or unsupported line of plastic does not distort from its drawn shape. It distorts only when another curing line or plastic comes into contact with it.
25 This second line of plastic shrinks as it is drawn, so if it contacts the first (previously cured) line, the first line will be bent towards the second. If we consider the first line to be constrained in some manner, the distortion caused by the second line will be affected by
30 the constraints to the extent that distortion will only occur in the areas of least resistance. If small gaps are made in this second line, then any stress that develops from the contact with the first line will be isolated between the gaps. If the gaps are used to separate
35 regions of strong structural strength from weaker regions, the stresses from the strong regions cannot propagate to the weaker ones and cause distortion there. Distortion at

any point will be less because the stress at that point is less.

Vertical distortions are a primary problem so we are generally concerned with placing Smalleys in regions on
5 layers above a critical layer, such as above the first layer of an unsupported region. Generally Smalleys are used to isolate regions from stress until they build up enough structural integrity to withstand the stress induced by curing successive layers. This will generally
10 require that the Smalleys be several layers in height. After sufficient strength is developed, the Smalleys can be removed.

There are several ways that Smalleys can be used to reduce distortion in an object:

15 1) Smalleys can be used to reduce distortion (separation of layers) and curl in solid areas of objects. This is especially true for cylindrical objects, but also true for other object geometries that have problems with distortion.

20 2) Smalleys can be placed at the ends of unsupported regions to reduce the distortion of the unsupported regions. This is especially true for upper edges of windows which are curved, and at the edge of a cantilever beam. Smalleys used in this way must be placed
25 one layer (no more, no less) above the unsupported region.

3) Smalleys can be used to reduce distortion in objects with wide internal regions by hollowing out these regions.

Designing Smalleys

30 The key to effective use of Smalleys is their proper placement at stress points in the CAD design. The following examples describe layer sections where Smalleys are typically used.

Example A: The continuous layer borders (LBs) of the
35 cylindrical part shown in Figure 7 generate relatively

large stresses. These stresses may cause curling if the layers are not adequately adhered to one another.

As shown in Fig. 7, Smalleys should be placed at 90 degree intervals around the circumference of the part, with each Smalley typically being 4 to 5 slice layers tall. Each successive set of Smalleys should be offset about 45 degrees to maintain the structural integrity of the part.

Example B: The unsupported upper edges of the curved windows shown in Figure 8 are highly susceptible to curling. Design Smalleys at the ends of the windows, as shown, but leave one continuous LB under each Smalley.

Example C: The thick interior structure of the part shown in Figure 9 will tend to curl the exterior flanges and other unsupported surfaces. A large Smalley, one that hollows out the interior of the part, as shown, will minimize these stresses.

Smalleys are typically designed on the CAD to be 15 to 30 mils wide and 40 to 80 mils tall. They generally decrease in size as the part is formed due to the viscous liquid filling the small gaps during dipping. Thus, if designed properly, Smalleys will prevent curl and then effectively disappear or reduce in size to narrow slits or slight indentations on the surface of the part during post curing.

Smalleys are also used to reduce birdnesting. The width of Smalleys, for this application, is generally less than cure width, so that after curing they are completely filled in and so no structural integrity is lost through their use. Smalleys are placed periodically in regions of down-facing, near-flat triangles with heights appropriate to extend vertically through the near-flat triangles. The placement of Smalleys is based on several factors that affect the likelihood of having birdnesting problems. The radius of curvature of the boundaries, the length of near-flat zones, the likelihood of boundaries moving, etc. are significant. Smalleys do not need to penetrate

completely through a wall, as they do in their other application, but they do need to penetrate deep enough to insure a contact point with the boundaries on the previous layer.

5 Birdnesting can occur in objects that do not have near-flat triangles, but only when there are adhesion problems between layers (for example, when an object is built using dip delays that are too short). Smalleys can be used in these situations to help eliminate birdnesting
10 also.

Smalleys can be used in a variety of situations that have down-facing near-flat skin. FIG. 10 is a side view of a CAD designed cone without Smalleys. FIGS. 11 and 12 are views of the sliced CAD designed cone and what it
15 might look like after building. FIG. 13 is a top view of a CAD designed cone showing possible locations in the XY plane where Smalleys might be inserted. FIG. 14 is a side view of a sliced CAD designed cone with Smalleys and what it might look like after building.

20 Boundary vectors can move out of position for a couple of reasons: 1) convection currents within the liquid that can cause floating items to drift, 2) distortions of boundary vectors from making contact with already cured (but floating material), 3) newly cured
25 material contacting, and distorting, boundary vectors before they are secured into position, and 4) shrinking of hatch as it starts to secure one side of the boundary causing the boundary to be pulled out of position. A couple of these causes can affect boundary vectors that
30 are not associated with near-flat triangles, so if problems are found in non-near-flat regions, Smalleys may be useful.

Boundaries can only birdnest when they can move or sections of them can move far enough out of position so
35 that when cross-hatching is drawn, it does not contact the boundaries. Smalleys avoid this problem by having the boundaries cut in over the top of the boundaries from the

previous layer, on a periodic basis. This cutting in over the top of previously cured boundaries prevents the present boundaries from moving out of position.

FIG. 15 is a top view of two cross-sections of a cone with no Smalleys. FIG. 16 is a top view of two cross-sections of a cone with the second layer only showing the boundary vectors drawn. FIG. 17 is a top view of two cross-sections of a cone with the second layer showing the boundary vectors not making contact with cross-hatch in a particular location. FIG. 18 is a top view of two cross-sections of a cone with Smalleys. FIG. 19 is a top view of two cross-sections of a cone with Smalleys with the second layer only showing the boundary vectors drawn. FIG. 20 is a top view of two cross-sections of a cone with Smalleys with the second layer showing the boundary vectors making contact with cross-hatch everywhere.

An example of one embodiment of a commercial system, provided by 3D Systems, Inc. of Sylmar, California, embodying the present invention, is illustrated and described by the enclosed appendices, wherein Appendix A is a 3D Systems, Inc. Beta Site Users Manual and Systems Manual describing the overall system for an early Model SLA-1 Stereolithography System, including installation and operation, and Appendix I is a 3D Systems, Inc. Stereolithography CAD/CAM Interface Specification.

The new and improved stereolithographic method and apparatus has many advantages over currently used methods for producing plastic objects. The method avoids the need of producing tooling drawings and tooling. The designer can work directly with the computer and a stereolithographic device, and when he is satisfied with the design as displayed on the output screen of the computer, he can fabricate a part for direct examination, information defining the object being specially processed to reduce curl, stress, birdnesting and other distortions, and increase resolution, strength and accuracy of

reproduction. If the design has to be modified, it can be easily done through the computer, and then another part can be made to verify that the change was correct. If the design calls for several parts with interacting design
5 parameters, the method becomes even more useful because all of the part designs can be quickly changed and made again so that the total assembly can be made and examined, repeatedly if necessary.

After the design is complete, part production can
10 begin immediately, so that the weeks and months between design and production are avoided. Ultimate production rates and parts costs should be similar to current injection molding costs for short run production, with even lower labor costs than those associated with
15 injection molding. Injection molding is economical only when large numbers of identical parts are required. Stereolithography is particularly useful for short run production because the need for tooling is eliminated and production set-up time is minimal. Likewise, design
20 changes and custom parts are easily provided using the technique. Because of the ease of making parts, stereolithography can allow plastic parts to be used in many places where metal or other material parts are now used. Moreover, it allows plastic models of objects to be
25 quickly and economically provided, prior to the decision to make more expensive metal or other material parts.

The present invention satisfies a long existing need in the art for a CAD and CAM system capable of rapidly, reliably, accurately and economically designing and
30 fabricating three-dimensional plastic parts and the like.

It will be apparent from the foregoing that, while particular forms of the invention have been illustrated and described, various modifications can be made without departing from the spirit and scope of the invention.
35 Accordingly, it is not intended that the invention be limited, except as by the appended claims.

Claims

1. An improved stereolithographic system, comprising:
 - 5 first means for providing tailored object defining data with respect to a three-dimensional object to be formed, said tailored data specifying gaps or holes in the structure of said object for reduction of stress and curl; and
 - 10 second means responsive to said tailored data for automatically forming said three-dimensional object.
2. An improved stereolithographic system as set forth in Claim 1, wherein said tailored data specifies Smalleys for reduction of curl and stress.
3. An improved stereolithographic system as set
15 forth in Claim 1, wherein said data isolates sections so that stresses cannot be propagated over large distances.
4. An improved stereolithographic system as set forth in Claim 1, wherein said data localizes stress in said object.
- 20 5. An improved stereolithographic system as set forth in Claim 1, wherein said data isolates stress to localized areas.
6. A system as set forth in Claim 2, wherein said Smalleys automatically reduce in size upon forming said
25 object.
7. A system as set forth in Claim 2, wherein said Smalleys reduce birdnesting structure.
8. A method for improved stereolithography, comprising the steps of:

providing tailored object defining data with respect to a three-dimensional object to be formed, said tailored data specifying gaps or holes in the structure of said object for reducing stress and curl; and
5 utilizing said tailored data to stereolithographically form said three-dimensional object.

9. A method for improved stereolithography as set forth in Claim 8, wherein said step of providing includes data which specifies Smalleys for reduction of curl and
10 stress.

10. A method for improved stereolithography as set forth in Claim 8, wherein said step of providing includes data which isolates sections so that stresses cannot be propagated over large distances.

15 11. A method for improved stereolithography as set forth in Claim 8, wherein said step of providing data localizes stress in said object.

12. A method for improved stereolithography as set forth in Claim 8, wherein said step of providing data
20 isolates stress to localized areas.

13. A method as set forth in Claim 9, wherein said step of providing data includes providing Smalleys which automatically reduce in size upon forming said object.

14. A method as set forth in Claim 9, wherein said
25 step of providing includes providing Smalleys which reduce birdnesting structure.

Fig. 1

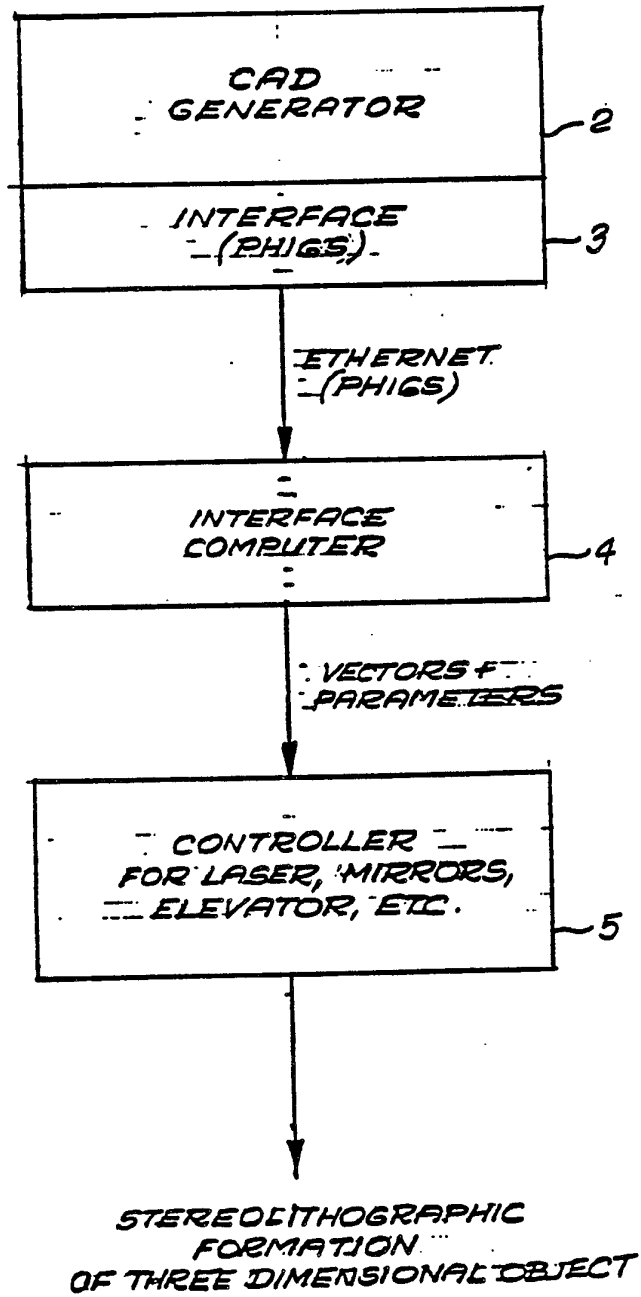

FIG. 2

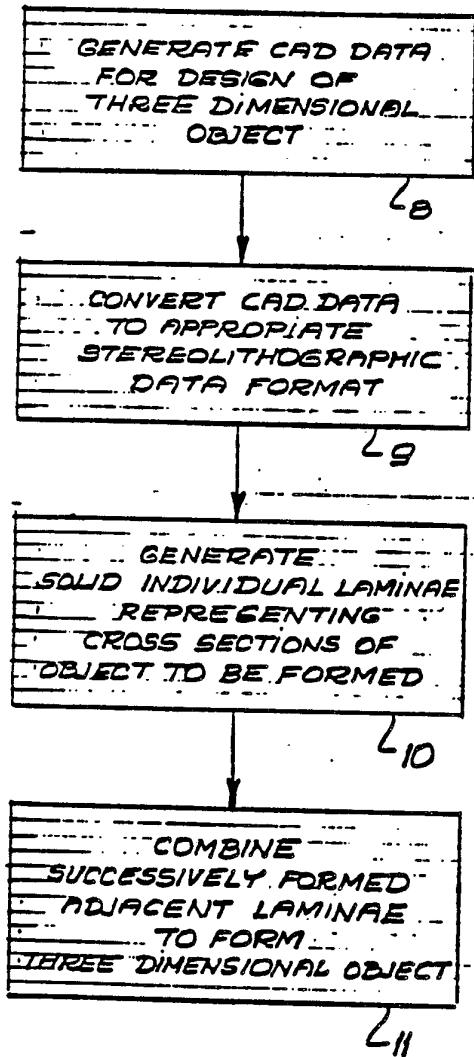
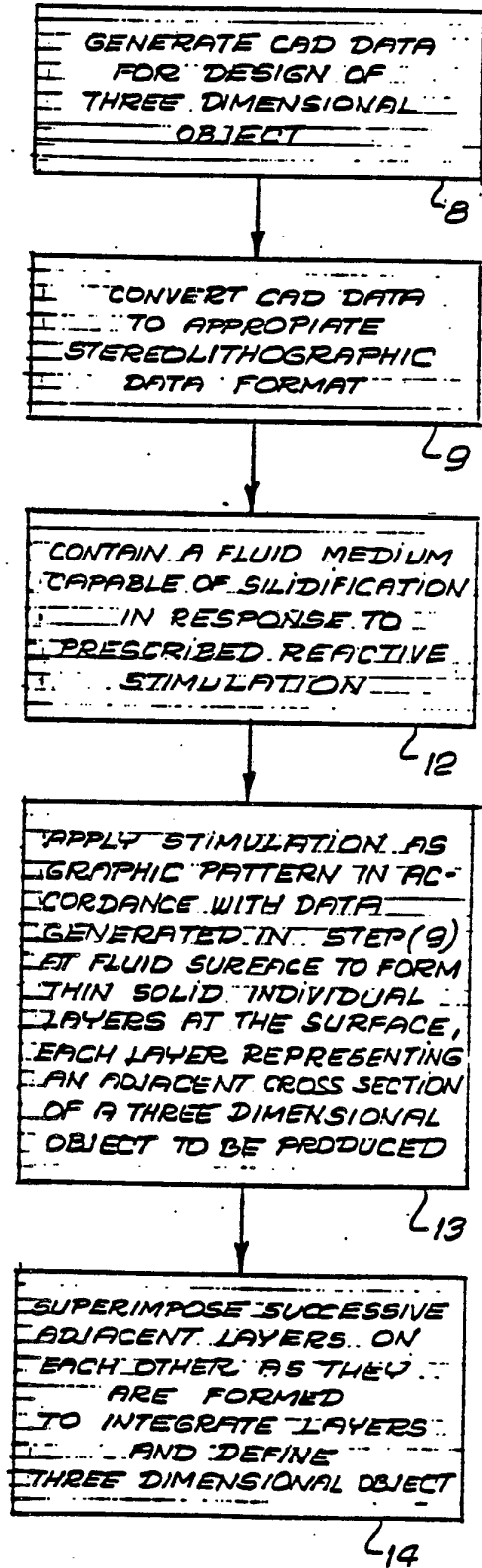
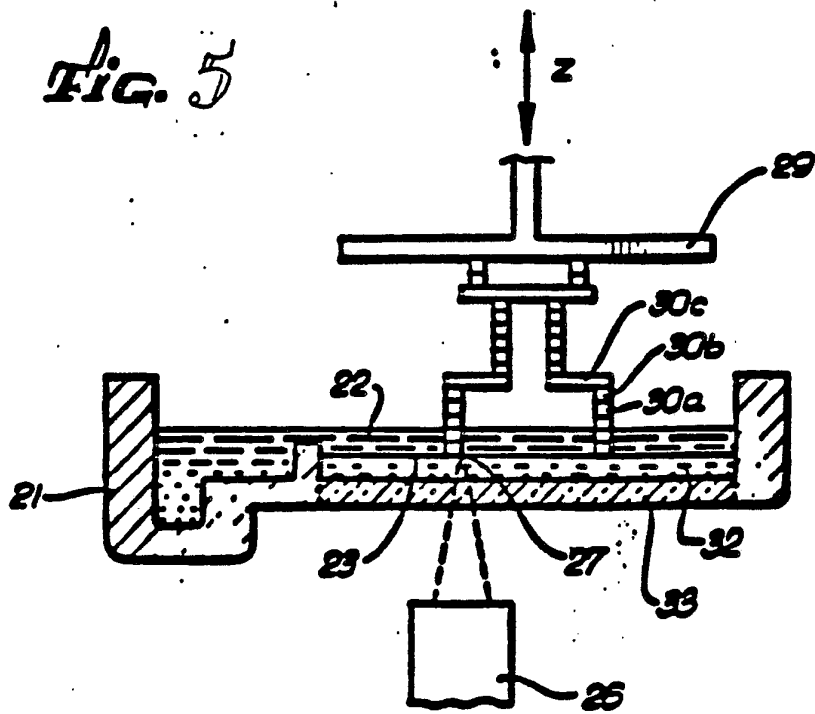
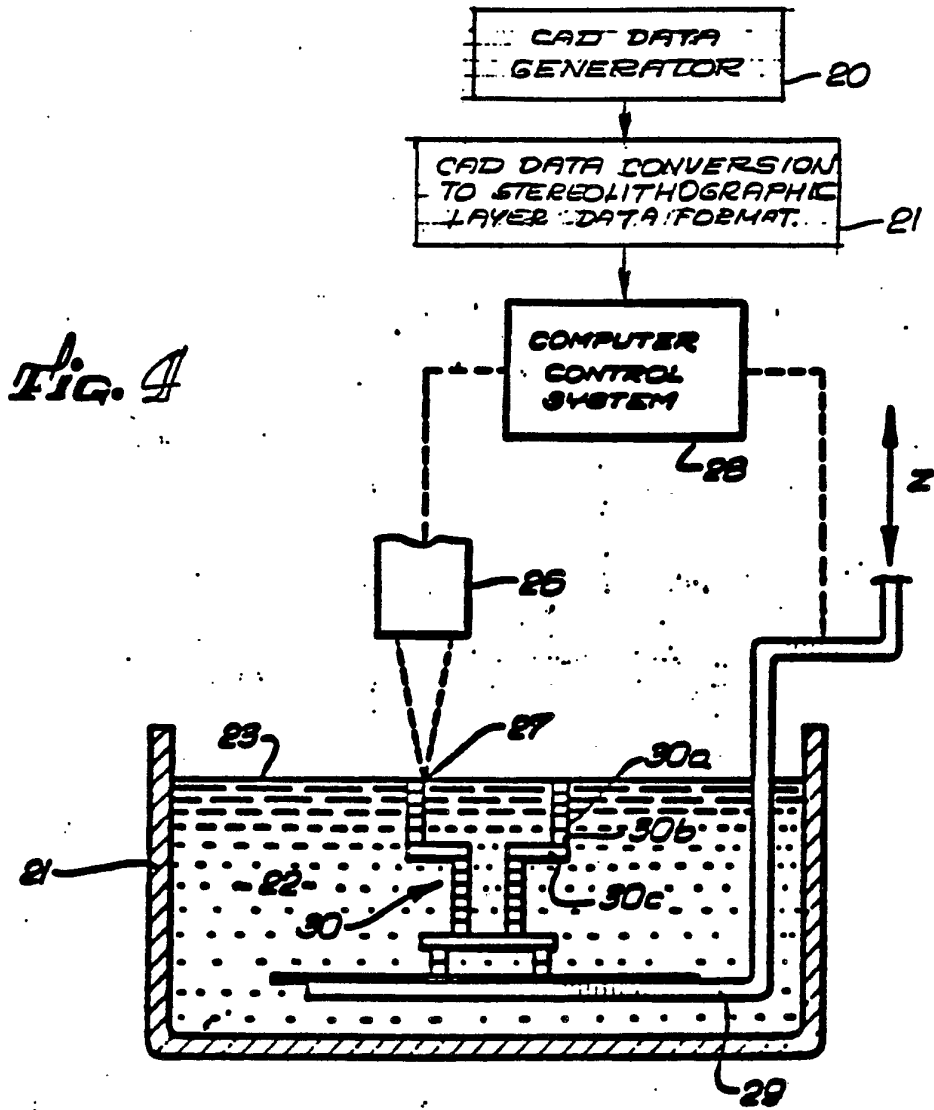
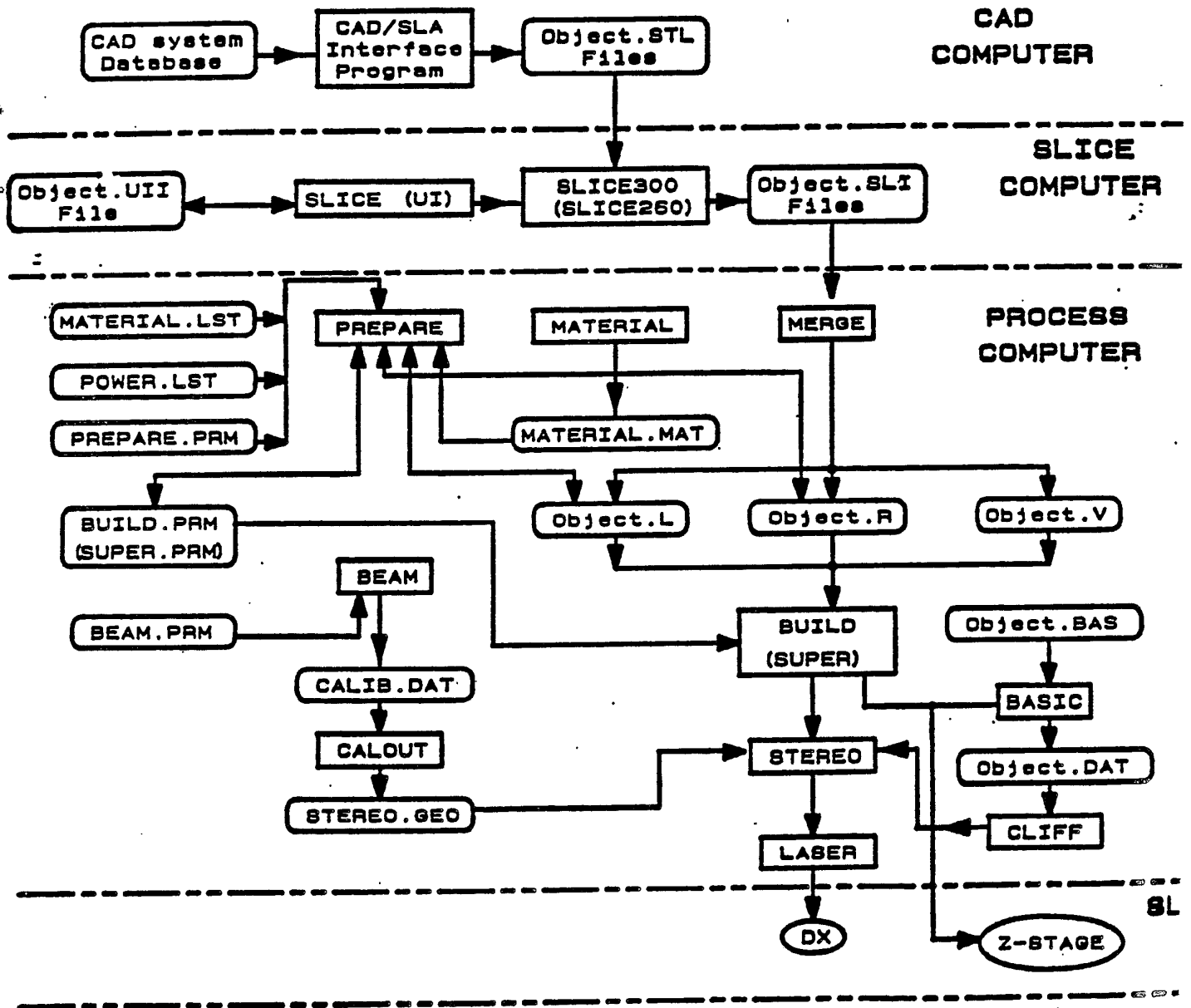

FIG. 3





SLA-1 SOFTWARE ARCHITECTURE



 : Data base or File

 : Program

FIG. 6

(NAME) indicates SLA Software Release 2.62 name

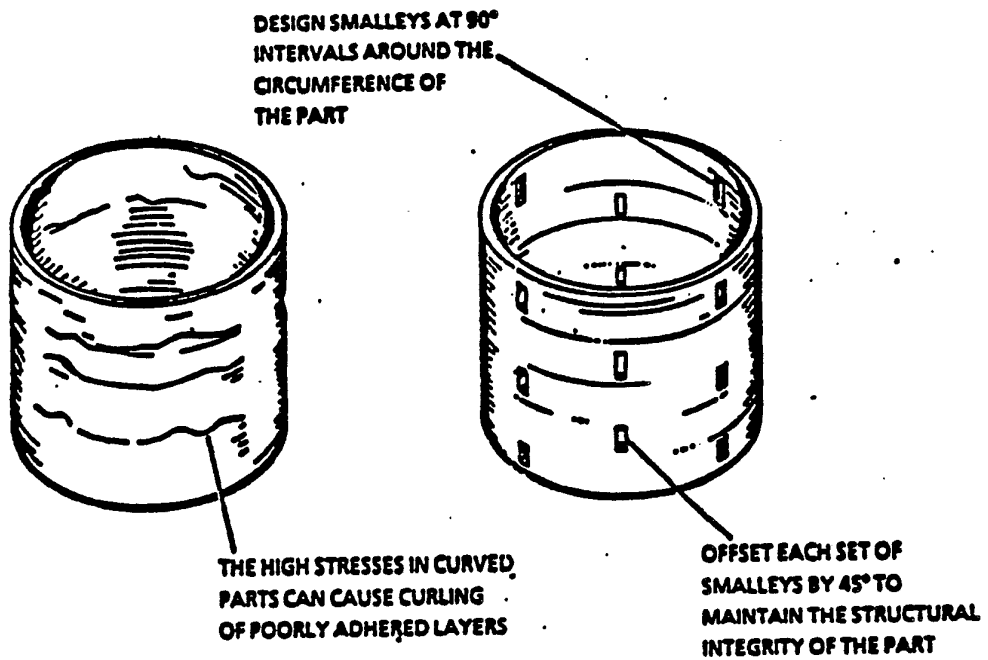

Fig. 7 Smalleys help prevent layer curling in cylindrical parts

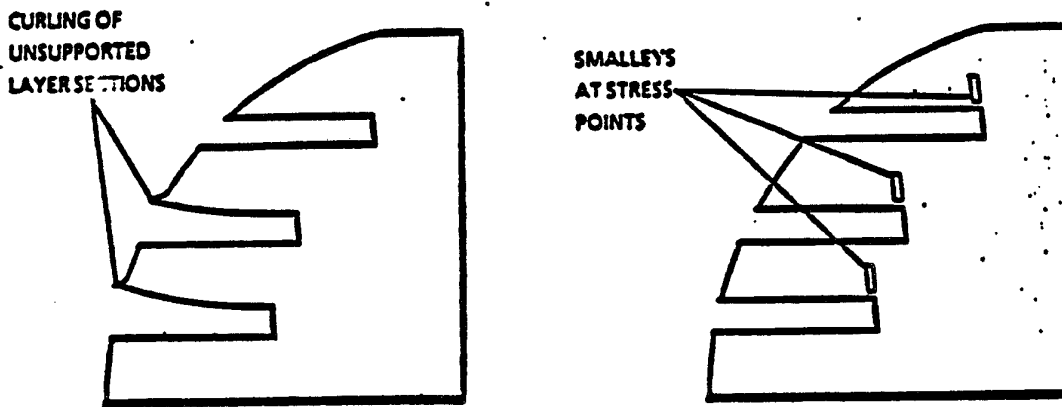

Fig. 8 Smalleys inhibit curling of unsupported layer sections

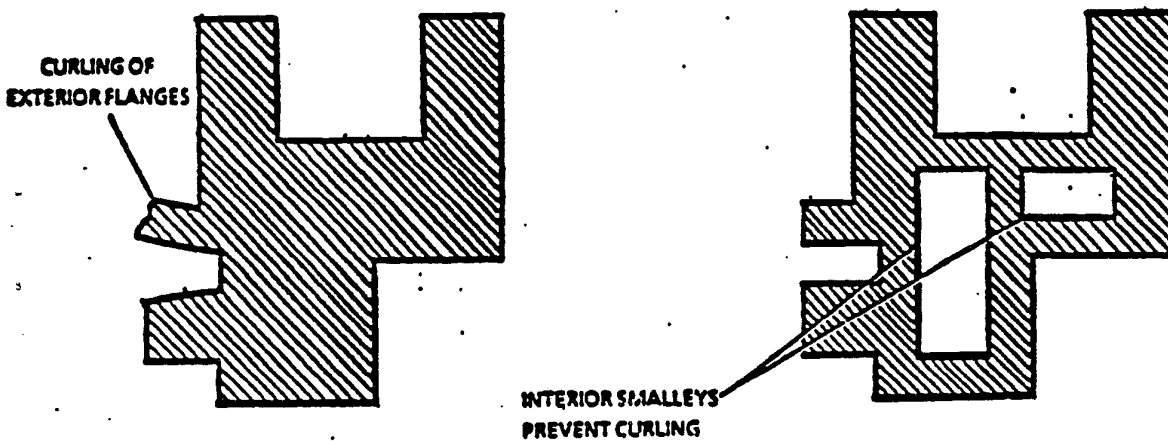

Fig. 9 Smalleys are used to hollow out thick interior structures to inhibit curling

FIG. 10

CAD DESIGNED
UP-FACING CONE

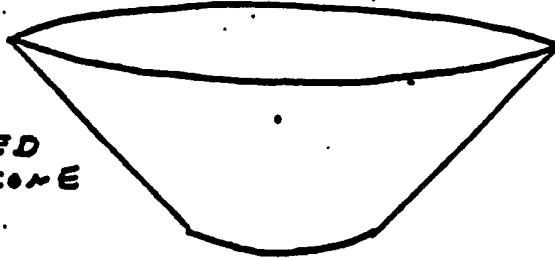

FIG. 11

DESIRED APPEAR-
ANCE OF CONE
AFTER BEING BUILT

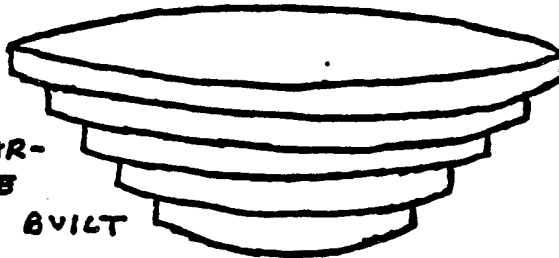

FIG. 12

POSSIBLE APPEARANCE
OF CONE AFTER BUILD-
ING, DUE TO BIRDNESTING

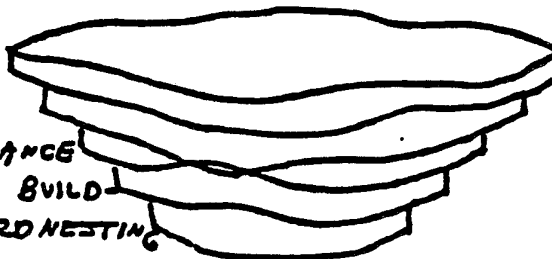
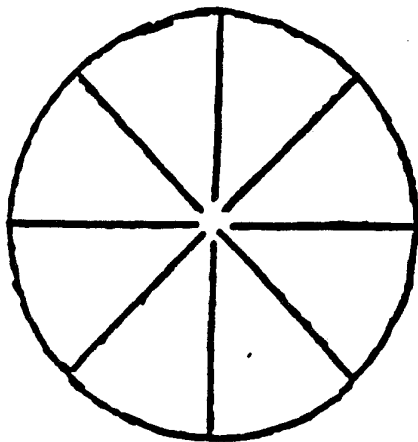
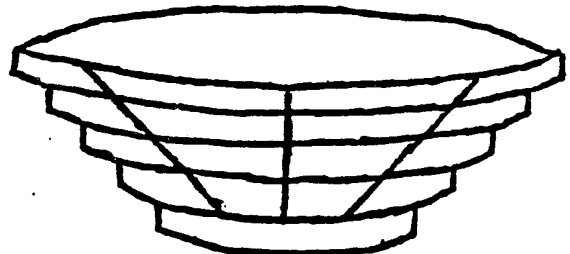

FIG. 13



POSSIBLE LOCATIONS OF
SMALLEYS TO INHIBIT
BIRDNESTING ON A GIVEN
CROSS SECTION

FIG. 14



POSSIBLE APPEARANCE
OF THE CONE AFTER
BEING BUILT WITH
SMALLEYS

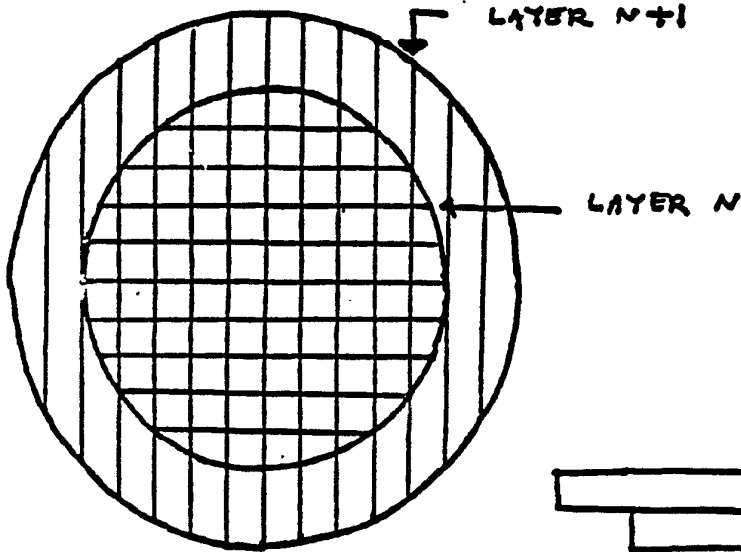
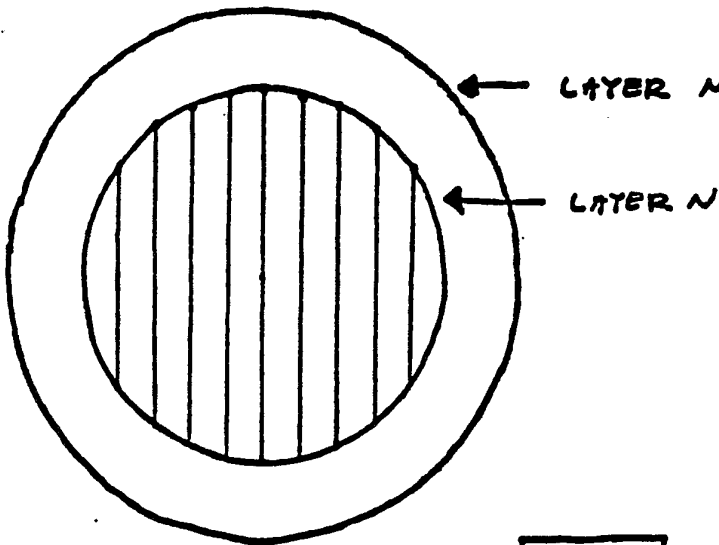
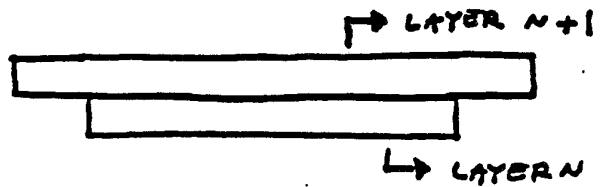

FIG. 15



LAYER N+1 . BOUNDARY, FLOATING
CAN MOVE BEFORE
IT IS ATTACHED.

FIG. 16

FIG. 17

AREAS
WHERE
CROSS HATCH
DOESN'T
CONTACT
BOUNDARY

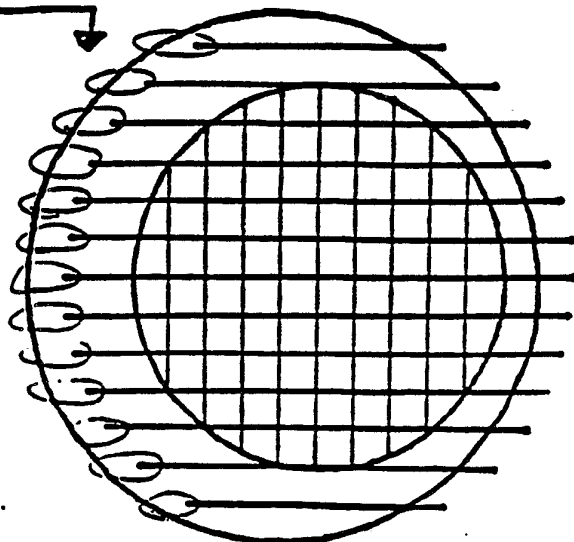

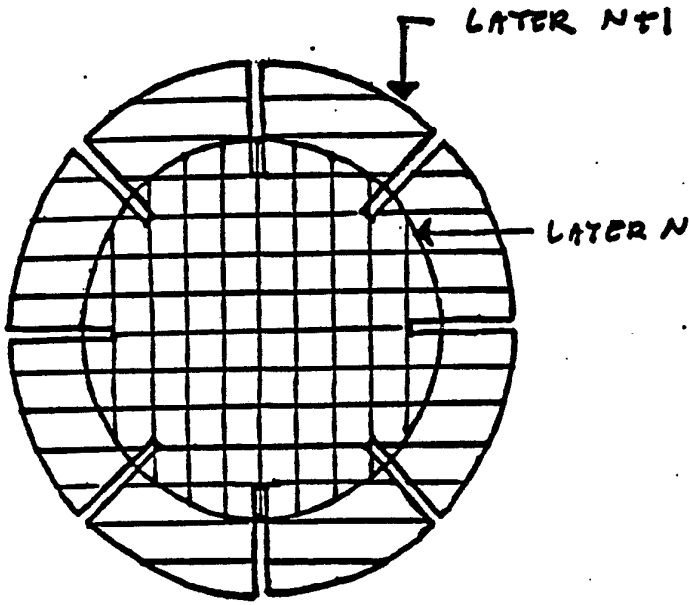

FIG. 18

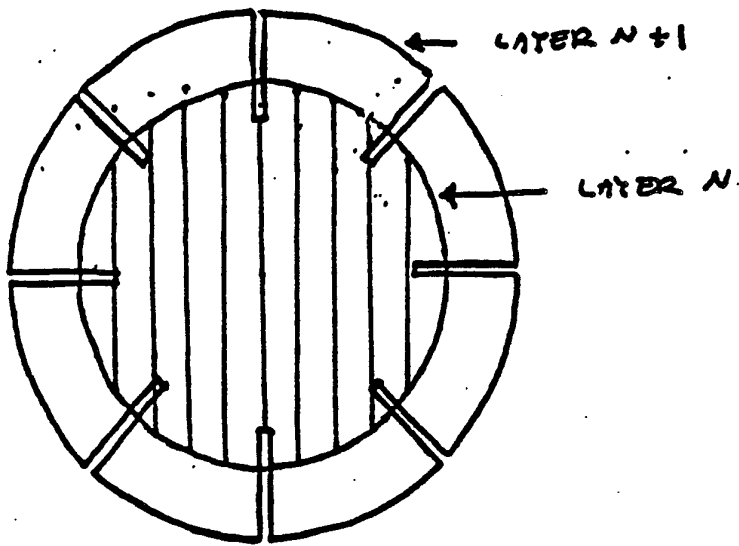
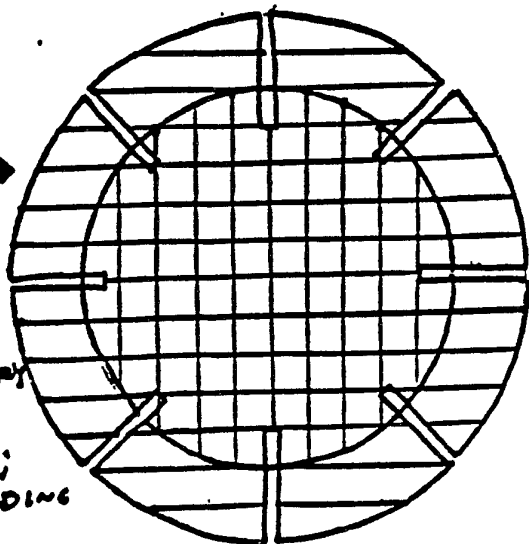

FIG. 19

FIG. 20

BOUNDARY →
MAKES
CONTACT WITH
CROSS HATCH
(SMALLETS
CAUSE BOUNDARY
TO CONTACT
PREVIOUS LAYER;
THEREFORE HOLDING
IT IN PLACE)



INTERNATIONAL SEARCH REPORT

International Application No. PCT/US89/01560

I. CLASSIFICATION OF SUBJECT MATTER (if several classification symbols apply, indicate all) ⁶		
According to International Patent Classification (IPC) or to both National Classification and IPC IPC(4): B29C 67/24; G11C 13/02; B32B 1/10 U.S.CL.: 264/22, 308; 156/58; 425/174.4; 427/43.1, 54.1; 365/106		
II. FIELDS SEARCHED		
Minimum Documentation Searched ⁷		
Classification System	Classification Symbols	
U.S.	264/22, 25, 40.1, 250, 255, 298, 308; 427/43.1, 54.1; 156/58, 273.3, 273.5, 275.5; 425/174.4; 365/106, 107, 119, 120, 127	
Documentation Searched other than Minimum Documentation to the Extent that such Documents are Included in the Fields Searched ⁸		
III. DOCUMENTS CONSIDERED TO BE RELEVANT ⁹		
Category *	Citation of Document, ¹¹ with indication, where appropriate, of the relevant passages ¹²	Relevant to Claim No. ¹³
X	US, A, 4,575,330 (HULL) 11 MARCH 1986 SEE THE ENTIRE DOCUMENT.	1-14
X	US, A, 2,775,758 (MUNZ) 25 DECEMBER 1956 SEE THE ENTIRE DOCUMENT.	1-7
X	HERBERT, "SOLID OBJECT GENERATION," J. Appl. PHOTO.ENG. VOL. 8, NO. 4, AUGUST 1982, pp. 185-188.	8-14
X	KODAMA, "AUTOMATIC METHOD FOR FABRICATING A THREE-DIMENSIONAL PLASTIC MODEL WITH PHOTO-HARDENING POLYMER," REV. SCI. INSTRUM., 52(11), NOVEMBER 1981, pp. 1770-1773.	1-14
Y,P	US, A, 4,801,477 (FUDIM) 31 JANUARY 1989,	
Y,P	US, A, 4,752,498 (FUDIM) 21 JUNE 1988,	
<p>* Special categories of cited documents: ¹⁰</p> <p>"A" document defining the general state of the art which is not considered to be of particular relevance</p> <p>"E" earlier document but published on or after the international filing date</p> <p>"L" document which may throw doubts on priority claim(s) or which is cited to establish the publication date of another citation or other special reason (as specified)</p> <p>"O" document referring to an oral disclosure, use, exhibition or other means</p> <p>"P" document published prior to the international filing date but later than the priority date claimed</p> <p>"T" later document published after the international filing date or priority date and not in conflict with the application but cited to understand the principle or theory underlying the invention</p> <p>"X" document of particular relevance; the claimed invention cannot be considered novel or cannot be considered to involve an inventive step</p> <p>"Y" document of particular relevance; the claimed invention cannot be considered to involve an inventive step when the document is combined with one or more other such documents, such combination being obvious to a person skilled in the art.</p> <p>"&" document member of the same patent family</p>		
IV. CERTIFICATION		
Date of the Actual Completion of the International Search		Date of Mailing of this International Search Report
27 June 1989		27 JUL 1989
International Searching Authority		Signature of Authorized Officer
ISA/US		<i>M.L. Fertig</i> M.L. Fertig