

G. H. BRIGGS.
 DETENT LEVER FOR GAS ENGINES.
 APPLICATION FILED JULY 8, 1910.

1,000,355.

Patented Aug. 8, 1911.
 2 SHEETS—SHEET 2.

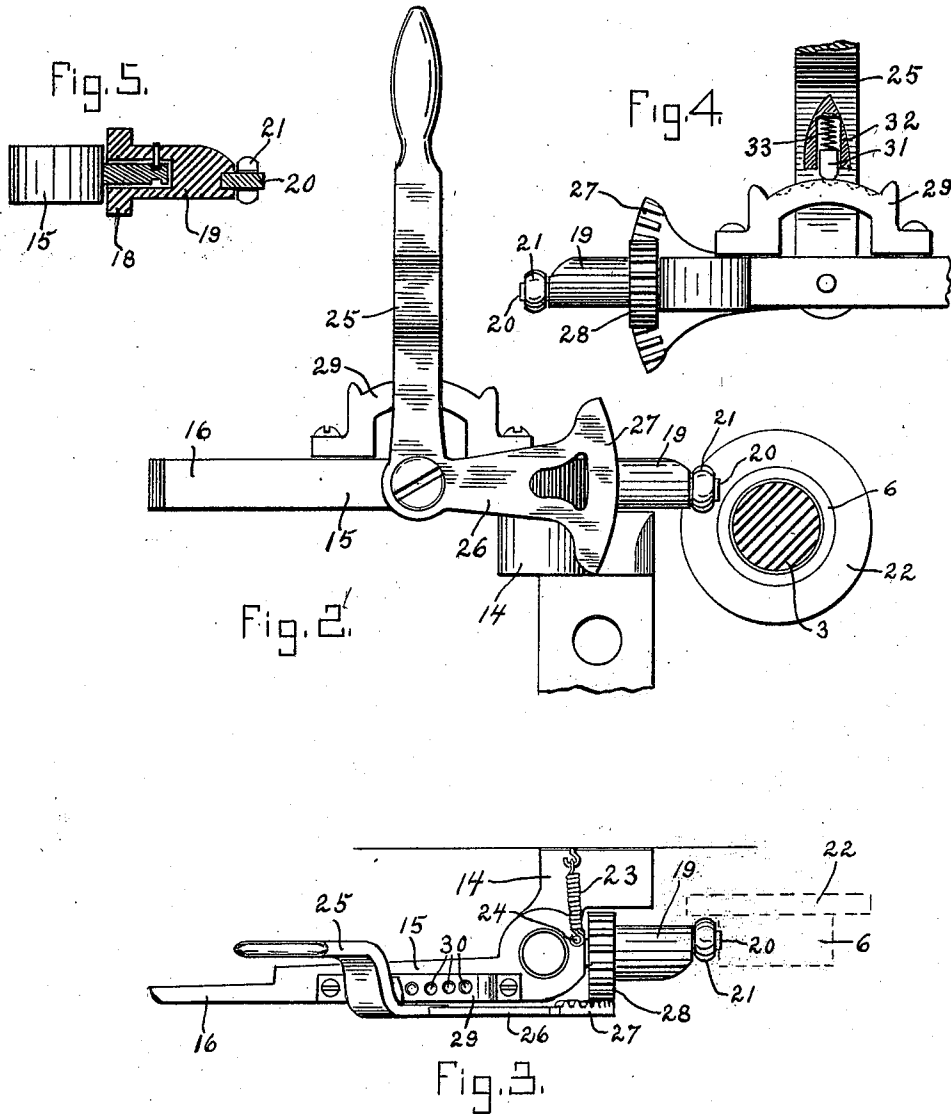

Witnesses

Frank W. Haskell
 Rev. M. H. Haskell

Inventor

George Herbert Briggs,
 by Walter N. Haskell,

his Attorney

UNITED STATES PATENT OFFICE.

GEORGE HERBERT BRIGGS, OF DE KALB, ILLINOIS, ASSIGNOR TO JACOB HAISH COMPANY, OF DE KALB, ILLINOIS.

DETENT-LEVER FOR GAS-ENGINES.

1,000,355.

Specification of Letters Patent. Patented Aug. 8, 1911.

Application filed July 8, 1910. Serial No. 571,074.

To all whom it may concern:

Be it known that I, GEORGE HERBERT BRIGGS, a citizen of the United States, residing at De Kalb, in the county of Dekalb and State of Illinois, have invented certain new and useful Improvements in Detent-Levers for Gas-Engines, of which the following is a specification.

My invention has reference to detent mechanism for gasolene engines, of that class wherein the speed of the engine is controlled by a centrifugal governor.

The principal purpose of my device is to regulate such control so that the action of the governor will be imparted to the operating parts of the engine more or less quickly, as desired.

In the accompanying drawings, Figure 1 is a plan view of an engine in which my invention is embodied. Fig. 2 is a side elevation of my device. Fig. 3 is a plan view thereof. Fig. 4 is an elevation thereof from the inner side, with some of the parts broken away. Fig. 5 is a detail view, showing the roller-arm in longitudinal section.

Similar parts are indicated by corresponding numbers of reference throughout the several figures.

1 represents the cylinder of the engine, 2 the piston thereof, and 3 the crank-shaft, upon the ends of which are balance-wheels 4. One of the wheels 4 is provided with the usual hub governor 5, engaging a collar 6 on the shaft 3, and adapted to move such collar longitudinally of the shaft.

Slidably mounted on the side of the engine is a rod 7, connected at one of its ends with a lever 8, adapted to actuate the exhaust valve of the engine. At its opposite end the rod 7 is provided with a roller 9, actuated by a cam 10 on a shaft 11 mounted on the frame of the engine. On the inner end of the shaft 11 is a gear-wheel 12, actuated by a gear-wheel 13 on the shaft 3. Upon the rotation of the shaft 3 movement is thus imparted to the rod 7 to cause a reciprocating movement thereof, and intermittently open the exhaust valve of the engine.

Fixed to the frame of the engine is a bracket 14, upon which is pivotally supported a detent lever 15, provided with a

finger 16, in proximity to the inner end of the rod 7, and normally out of engagement with a pin 17 projecting outwardly from such rod.

Rotatably mounted on a pin 18 fixed in the lever 15 is a roller-arm 19, in the outer end of which is eccentrically held a pin 20, carrying a small roller 21, adapted to be engaged by a flange 22 on the collar 6. The outward movement of such collar operates to move the detent finger 16 inwardly, causing the end thereof to engage the pin 17, preventing the return movement of the rod 7, and holding the exhaust valve of the engine open. Upon the collar 6 being again moved inwardly upon the shaft 3 the detent finger is permitted to return to its former position, such return movement being effected by means of a spring 23, secured at one end to the engine and at the opposite end to a post 24 on the lever 15.

Fulcrumed on the detent lever 15 is a lever 25, having a short arm 26, provided on its inner face with an arc-shaped rack 27, engaging a pinion 28 on the inner end of the roller-arm 19. The movement of the lever 25 operates to rotate the roller-arm, and change the position of the pin 20 with reference to the longitudinal center of the roller-arm. The apparent result is to move the pin 20 away from or toward the flange 22, but as the roller 21 on such pin is at all times in contact with said flange, the real effect is the movement of the detent finger 16 toward the arm 7, or away therefrom. It will be apparent that when the roller-arm 19 is turned so as to bring the pin 20 on the inner side thereof, as shown in Fig. 3, the detent lever will engage the pin 17 more quickly than when the pin 20 is turned to a more outward position on such roller-arm.

Mounted on the detent-lever 15, adjacent to the lever 25, is an arch 29, having a series of indentations 30, adapted to be engaged by a pin 31 in a socket 32 on the inner face of the lever 25. The engagement of the pin 31 with said indentations is sufficient to hold the lever 25 in the adjusted positions in which it may be placed, but will not interfere with the movement of the lever by the application of force thereto.

By the means just described the lever 25

is capable of being held in adjusted positions, with the roller-arm 19 in position with the pin 20 on the inner side thereof, or on the outer side, or at points intermediate thereof, as desired.

Accidental release of the pin 31 from the indentations in the arch 29 is prevented by a coiled spring 33 in the socket 32, which spring does not interfere with the movement of the lever 25 upon application of force thereto. It is thereby rendered possible to vary the position of the roller-arm 19 by operation of the lever 25, while the engine is in motion.

What I claim as my invention, and desire to secure by Letters Patent of the United States, is:

1. A device of the class named, comprising a pivotally supported lever, provided at one end with a detent finger; a roller-arm, forming the short end of said lever, and provided at its outer end with an eccentrically mounted pin; and means for holding said roller-arm in adjusted positions.

2. A device of the class named, comprising a pivotally supported lever, provided at one end with a detent finger; a roller-arm, forming the short end of said lever, and provided at its outer end with an eccentrically mounted pin; a gear pinion integral with said roller-arm; a hand lever, fulcrumed on said detent lever, and provided on its short end with a rack-gear adapted to actuate

said gear pinion; and means for holding said hand-lever in adjusted positions.

3. A device of the class named, comprising a pivotally supported lever, provided at one end with a detent finger; a roller-arm forming the short end of said lever, and provided at its outer end with an eccentrically mounted pin; a hand lever, fulcrumed on said detent lever; an arch, mounted on said detent lever, and provided on one of its faces with a series of indentations; a spring-controlled pin, supported on said hand-lever, and adapted to severally engage said indentations, and means for imparting the movement of said hand-lever to said roller-arm, to rotate the same.

4. In combination with the crank-shaft of a gasolene engine, and collar, slidably mounted thereon; a rotatable roller-arm, having contact with said collar eccentrically of the axis of such roller arm; a detent-lever, adapted to be actuated by said roller-arm; means for holding said roller-arm in contact with said collar; means for holding said roller-arm in adjusted positions; and governor mechanism adapted to suitably actuate said collar.

In testimony whereof I affix my signature in presence of two witnesses.

GEORGE HERBERT BRIGGS.

Witnesses:

SIMON JOHNSON,
CARL BARINE.