



US 20070125231A1

(19) **United States**

(12) **Patent Application Publication**

Thomas et al.

(10) **Pub. No.: US 2007/0125231 A1**

(43) **Pub. Date: Jun. 7, 2007**

(54) **PRESSURE EQUALISATION DEVICE**

(30) **Foreign Application Priority Data**

(76) Inventors: **Alan Thomas**, Wiltshire (GB); **Colin Gradwell**, Wiltshire (GB); **Mark Hemmings**, Wiltshire (GB)

May 9, 2003 (GB)..... 0310701.8

Publication Classification

Correspondence Address:
BARNES & THORNBURG LLP
750-17TH STREET NW
SUITE 900
WASHINGTON, DC 20006-4675 (US)

(51) **Int. Cl.**
B01D 53/22 (2006.01)
(52) **U.S. Cl.** **96/4; 55/385.4**

(57) **ABSTRACT**

A pressure equalisation device adapted to be operatively connected to an enclosure, the device including an air passage which, when the device is so connected to the enclosure, provides a fluid communication between the interior of the enclosure and atmosphere, the air passage containing a barrier wall comprising an air permeable membrane forming a micro-particulate filter.

(21) Appl. No.: **10/556,167**
(22) PCT Filed: **May 10, 2004**
(86) PCT No.: **PCT/GB04/02015**
§ 371(c)(1),
(2), (4) Date: **Jul. 31, 2006**

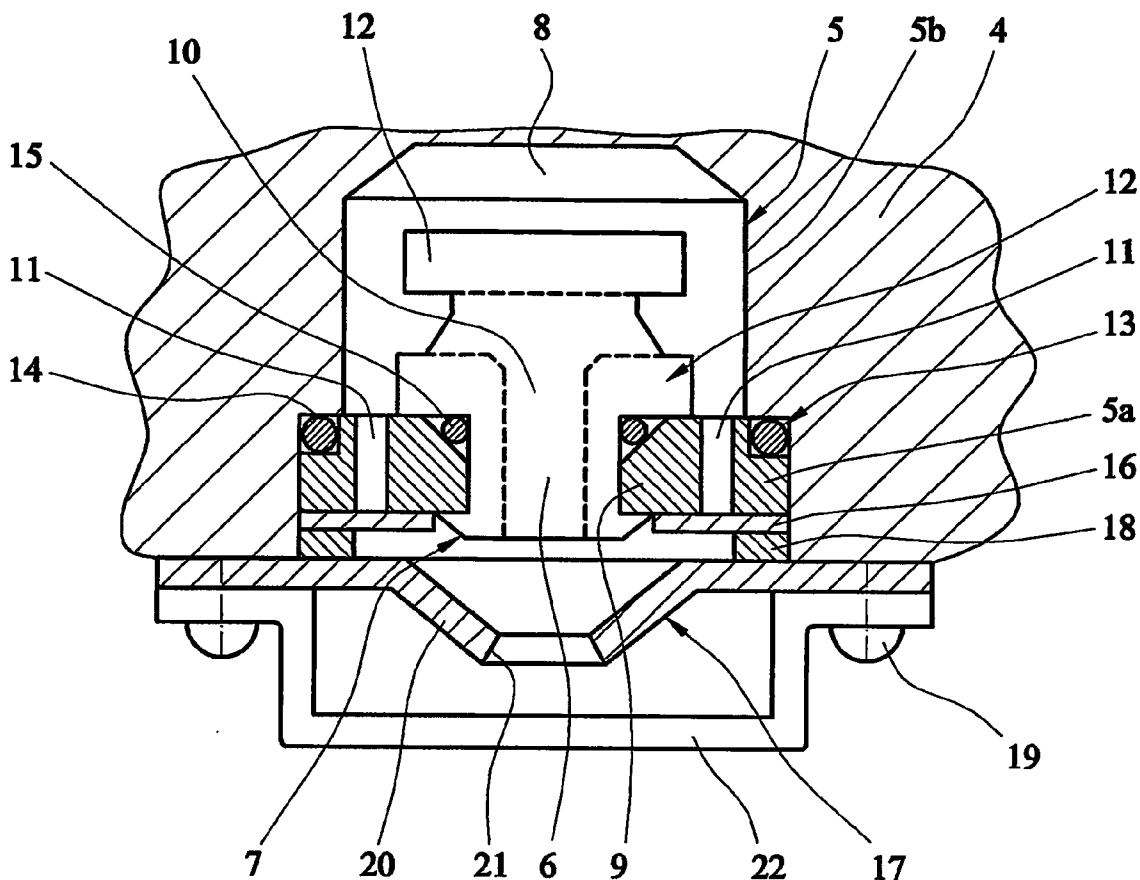

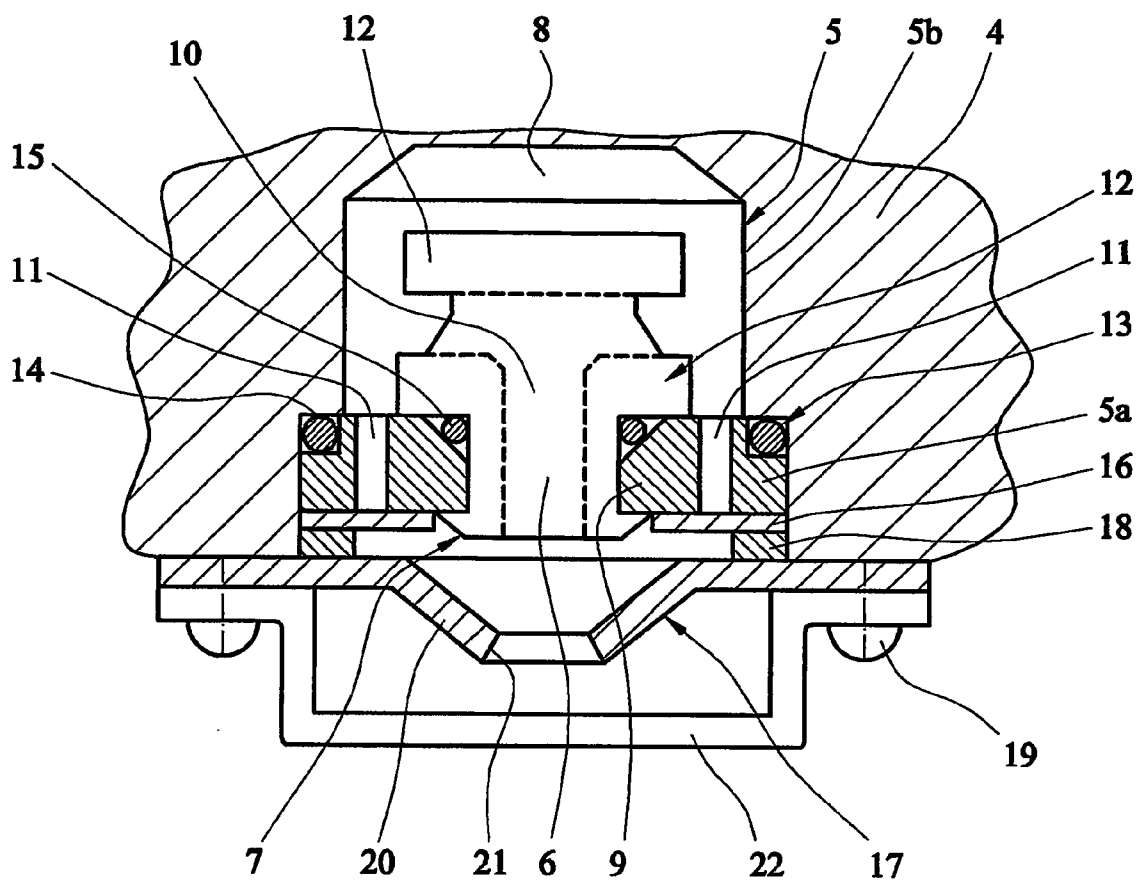

FIG. 1

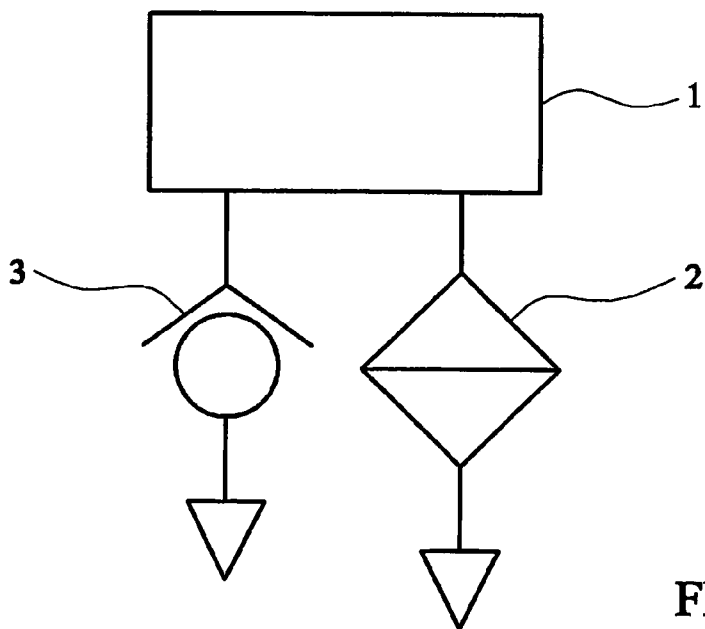

FIG. 2

PRESSURE EQUALISATION DEVICE

[0001] The present invention relates to a pressure equalisation device adapted to be operatively connected to an enclosure to ensure that, during operation, the pressure in the enclosure is substantially equal to atmospheric pressure at all times.

[0002] In many situations, sensitive equipment, such as electrical equipment, printed circuits, pneumatic control circuits and hydraulic control circuits, is used in exposed environmental conditions, from which the equipment must be protected. In many cases, the problem is solved by encasing the equipment entirely in a protective enclosure which is completely sealed from the exterior atmosphere. However, such a solution is not possible where the equipment to be protected includes pressure members or transducers which are required to be responsive to atmospheric pressure. Atmospheric pressure, of course, varies with atmospheric conditions and this problem is compounded when the equipment is used on a vehicle whose height above sea level can vary throughout each journey. In such installations, it is necessary to have the interior of a protective enclosure vented to atmosphere through an air vent or pressure equalisation device to ensure that the air pressure within the protective enclosure is maintained substantially at atmosphere.

[0003] Particularly, when mounted on vehicles such as rail cars, the enclosure and the air vents are subjected to a harsh environment which includes dust and water and it is necessary to exclude such foreign matter from entering the enclosure through the pressure equalisation device, to prevent damage to the equipment inside the enclosure.

[0004] The present invention seeks to provide a solution to this problem and, particularly but not essentially, to provide a pressure equalisation device for an enclosure which can meet the requirements of BS EN 60529: 1992 IP 66. IP 66 is an industry standard for instrument protection, the first digit indicating a level of protection against solid objects, 6 being no ingress of dust possible, the second digit indicating a level of protection against liquids, 6 being protection against powerful jets of water.

[0005] According to the present invention there is provided a pressure equalisation device adapted to be operatively connected to an enclosure, the device including an air passage which, when the device is so connected to the enclosure, provides a fluid communication between the interior of the enclosure and atmosphere, the air passage containing a barrier wall comprising an air permeable membrane forming a particulate filter.

[0006] Preferably, the barrier wall extends across the air passage and a predetermined distance along the passage so as to have an area subjected to the air flow which is greater than the cross-sectional area of the passage.

[0007] Preferably, the device comprises a carrier for the barrier wall, the carrier being sealingly insertable in a bore in a wall of the enclosure, the air passage being formed in part by said bore.

[0008] The permeable membrane preferably forms a micro particulate filter, which may be formed of a polymer material.

[0009] Preferably, the barrier wall also forms a water barrier preventing the increase of water into the enclosure. The device may also include a baffle means to inhibit water entering the air passage. When the device comprises a carrier for the barrier wall, the baffle may serve to clamp the carrier to the enclosure.

[0010] The device preferably includes a second air passage in parallel with the first air passage for venting the enclosure, the second air passage including a one-way vent valve adapted to permit air flow out of the enclosure through said second air passage but to prevent air flowing into the enclosure through said second air passage. Preferably, the second air passage is formed in said carrier, the one-way vent valve comprising a resilient diaphragm biased to close said second air passage and being urged to a closed position by air flowing in a direction towards the enclosure and being opened against the resilient bias by air flowing out of the enclosure.

[0011] A preferred embodiment of the present invention will now be described by way of example with reference to the accompanying drawings, in which:

[0012] FIG. 1 shows cross-section through a pressure equalisation device, and

[0013] FIG. 2 shows a schematic form of a vent arrangement and a sealed enclosure.

[0014] Referring now to FIG. 2 there is shown a schematic layout of an embodiment of the present invention, for providing pressure equalisation between the interior of a sealed enclosure 1 and atmosphere. The pressure equalisation device comprises an air permeable device 2 which permits air to flow to and from the interior of the enclosure and a one-way vent valve 3 which permits air to flow out of the interior of the enclosure 1 but prevents air from flowing into the enclosure 1.

[0015] Referring now to FIG. 1, there is shown in schematic form a cross-sectional view of a pressure equalisation device 2 incorporated in a wall 4 of a sealed enclosure 1. In this particular embodiment, the sealed enclosure 1 comprises the housing 4 of an air pressure operated brake control valve for a railway braking system, which contains gauge pressure sensitive components, but which will not be described in any more detail.

[0016] The housing wall 4 has a stepped bore 5 providing an air passage 6 having an inlet 7 exposed to atmospheric pressure and an outlet 8 leading into the interior of the enclosure. The larger diameter portion 5a of the bore 5 contains an annular carrier 9 having a central opening 10 which defines the first air passage 6, and a plurality of axially extending bores 11 arranged about the carrier 9 on a diameter smaller than the smaller diameter 5b of the stepped bore 5 in the housing and which form a second air passage.

[0017] On the side of the carrier 9 leading towards the interior of the enclosure, the first air passage is closed by an air permeable membrane 12 which extends along the axial direction of the air passage 6 towards the interior of the enclosure 1 so that the surface area of the membrane which is subjected to the passage of air is substantially greater than the cross-sectional area of the opening 10 in the carrier 9. The membrane 12 is formed of a microporous polymer which is air permeable but provides a micro-particulate filter

to prevent any dust entering the enclosure through the air passage 6. A suitable material is sold by WL Gore Inc. under the Trademark GORE-TEX. The membrane is preformed in a semi-rigid condition so that it overlies the carrier 9 and maintains its shape in the installed condition in which it is clip-fastened into the opening 10 in the carrier 9 for ease of assembly. The carrier 9 is sealed in the stepped bore 5a by an annular ring seal 13 located between the carrier 9 and the shoulder 14 of the stepped bore 5 whilst a further annular ring seal 15 is located between the wall of the opening on the carrier 9 and the membrane 12 to prevent the ingress of air past the membrane 12. A resilient annular silicon rubber diaphragm 16 is located on the outside of the carrier 9 and is clamped in position through a spacer 18 by a baffle plate 17 secured to the outer surface of the wall of the enclosure by screws 19.

[0018] The diaphragm 16 forms a one-way check valve for the second air passage formed by the bores 11. In its normal position the diaphragm 16 lies against the face of the carrier 9 to close the second air passage, as shown. When a substantial quantity of air flows from the interior of the enclosure 1 towards atmosphere, the resilient diaphragm deflects to open the second air passage. In the absence of a substantial air flow, the diaphragm lies in its closed position to close the second air passage but if air flows in the inward direction towards the interior of the housing, the higher external pressure urges the diaphragm 16 against the surface of the carrier 9 to securely and air tightly close the bores 11. In this way, in normal circumstances where the device balances the minor fluctuations in pressure differential which occur due to atmospheric conditions and changes in height of the vehicle, the second air passage remains closed but if there is, for example, a failure in the braking system which results in the generation of high pressure in the interior of the enclosure, this high pressure is vented through the second air passage, which minimises the risk of damage being caused to the barrier wall 12.

[0019] The baffle plate 17 has an outwardly extending frusto-conical section 20 axially aligned with the opening 6 in the carrier and having a central bore 21 through which air can flow into the pressure equalisation device. Outside this the baffle plate is shielded by a further, channel-shaped baffle 22 which is also secured to the enclosure housing 4.

[0020] In operation, the pressure in the interior of the enclosure is maintained at atmospheric pressure by air passing in the appropriate direction through the barrier wall 12. The micro-particulate filter characteristic of the membrane prevents the ingress of any dust into the enclosure. In the working condition, when installed on a railway vehicle, the enclosure 1 is subjected to water impact, which can impinge on the housing with a great force as a jet of water if the vehicle passes through standing water, for example, at high-speed. To prevent this impinging directly on the membrane, which is designed to prevent water passing through, a first line of defence is provided by the channel shaped baffle plate 22 which prevents water impinging directly on the membrane 12. Water can pass along the channel flowing laterally of the axis of the first air passage 6 so that to enter the air passage it must change direction by 90 degrees and flow up through the opening in the inner baffle plate 17 before impinging on the membrane 12. In this way, the vast majority of the force of the water is deflected or broken before the water contacts the membrane which reduces the risk of damage to the membrane and also the risk

of water being forced through by rupturing the membrane 12. Water is prevented from passing through into the interior of the housing through the membrane 12 since the pores in the membrane are smaller than molecules of water.

[0021] The second air passage formed by the plurality of bores 11 in the carrier is normally closed by the annular diaphragm 16 but if the pressure in the interior of the enclosure rises rapidly due, for example, to a failure in the pneumatic braking circuits, the air can flow out through the second air passage, urging diaphragm 16 to the open position, to therefore prevent the excessive air pressure damaging the membrane 12.

[0022] Although described with reference to a railway braking system, it will be appreciated that invention is applicable to many other types of installation where protection from the elements is necessary. Although described as being for the equalisation of pressure in an enclosure with atmosphere, it could be used in installations where other gases are used in other environments.

1. A pressure equalization device adapted to be operatively connected to an enclosure, the device including a first air passage which, when the device is so connected to the enclosure, provides a fluid communication between the interior of the enclosure and atmosphere, the first air passage containing a barrier wall comprising an air permeable membrane forming a particulate filter.

2. A device according to claim 1, wherein the barrier wall extends across the first air passage and a predetermined distance along the passage so as to have an area subjected to the air flow which is greater than the cross-sectional area of the passage.

3. A device according to claim 1, including a carrier for the barrier wall, the carrier being sealingly insertable in a bore in a wall of the enclosure, the first air passage being formed in part by said bore.

4. A device according to claim 3, wherein the permeable membrane forms a micro-particulate filter.

5. A device according to claim 4, wherein the filter is formed of a polymer material.

6. A device according to claim 1, wherein the barrier wall also forms a water barrier preventing the ingress of water into the enclosure.

7. A device according to claim 3, further including baffle means to inhibit water entering the air passage.

8. A device according to claim 7, wherein the baffle means serves to clamp the carrier to the enclosure.

9. A device according to claim 1, including a second air passage in parallel with the first air passage for venting the enclosure, the second air passage including a one-way vent valve adapted to permit air flow out of the enclosure through said second air passage but to prevent air flowing into the enclosure through said second air passage.

10. A device according to claim 9, wherein the second air passage is formed in said carrier, the one-way vent valve comprising a resilient diaphragm biased to close said second air passage and additionally being urged to a closed position by air flowing in a direction towards the enclosure and being opened against the resilient bias by air flowing out of the enclosure.

11. A device according to claim 1, further including baffle means to inhibit water entering the air passage.