

J. C. STEARNS.
ELECTRIC LIGHT ATTACHMENT FOR GAS LAMPS.
APPLICATION FILED JAN. 31, 1910.

974,930.

Patented Nov. 8, 1910.

2 SHEETS—SHEET 1.

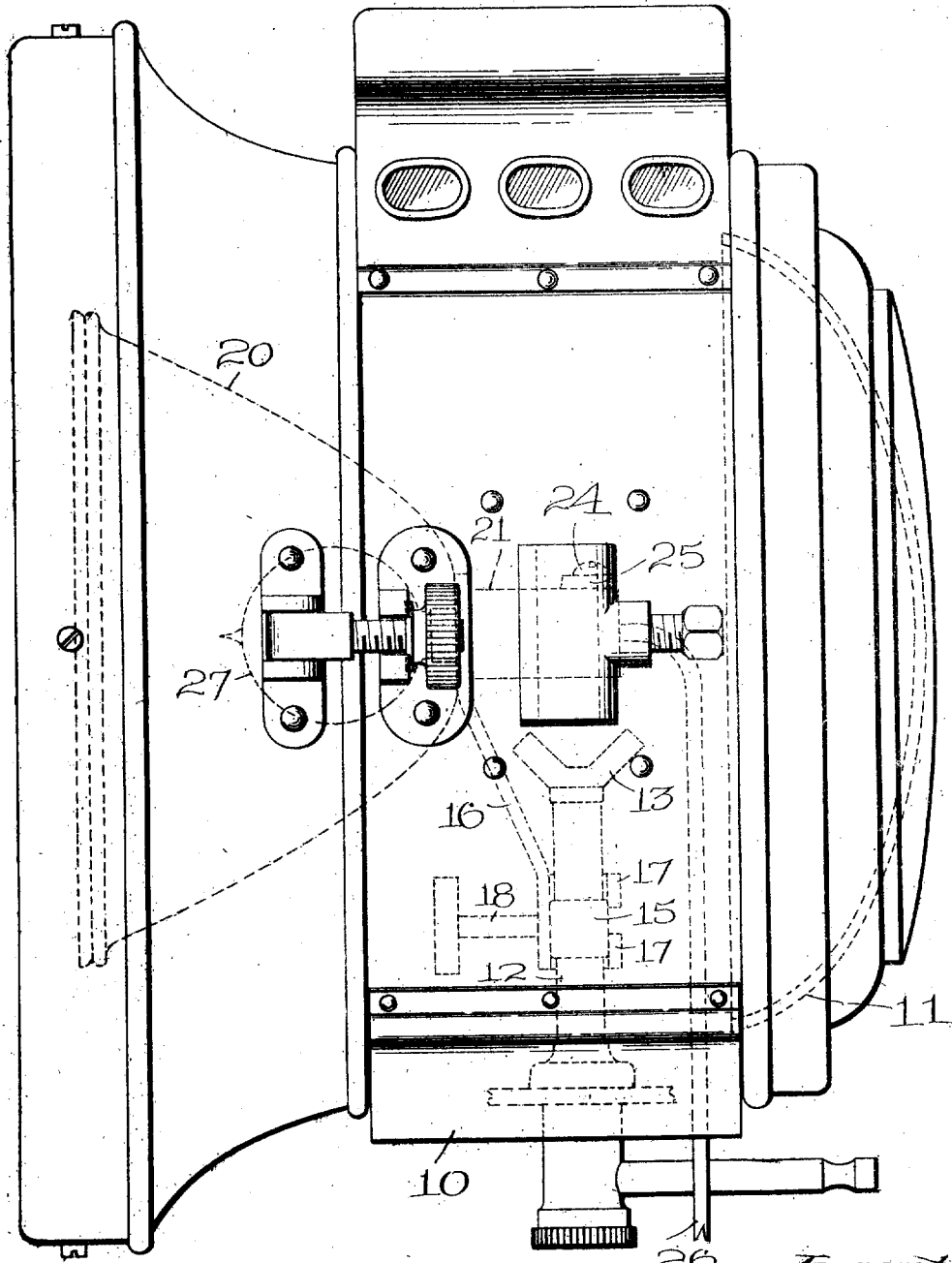

Witnesses:
L. F. Mason
E. W. Allen.

FIG. 1.

Inventor
J. C. Stearns.
S. O'Herniss
Southard & Southgate

J. C. STEARNS.
 ELECTRIC LIGHT ATTACHMENT FOR GAS LAMPS.
 APPLICATION FILED JAN. 31, 1910.

974,930.

Patented Nov. 8, 1910.

2 SHEETS—SHEET 2.

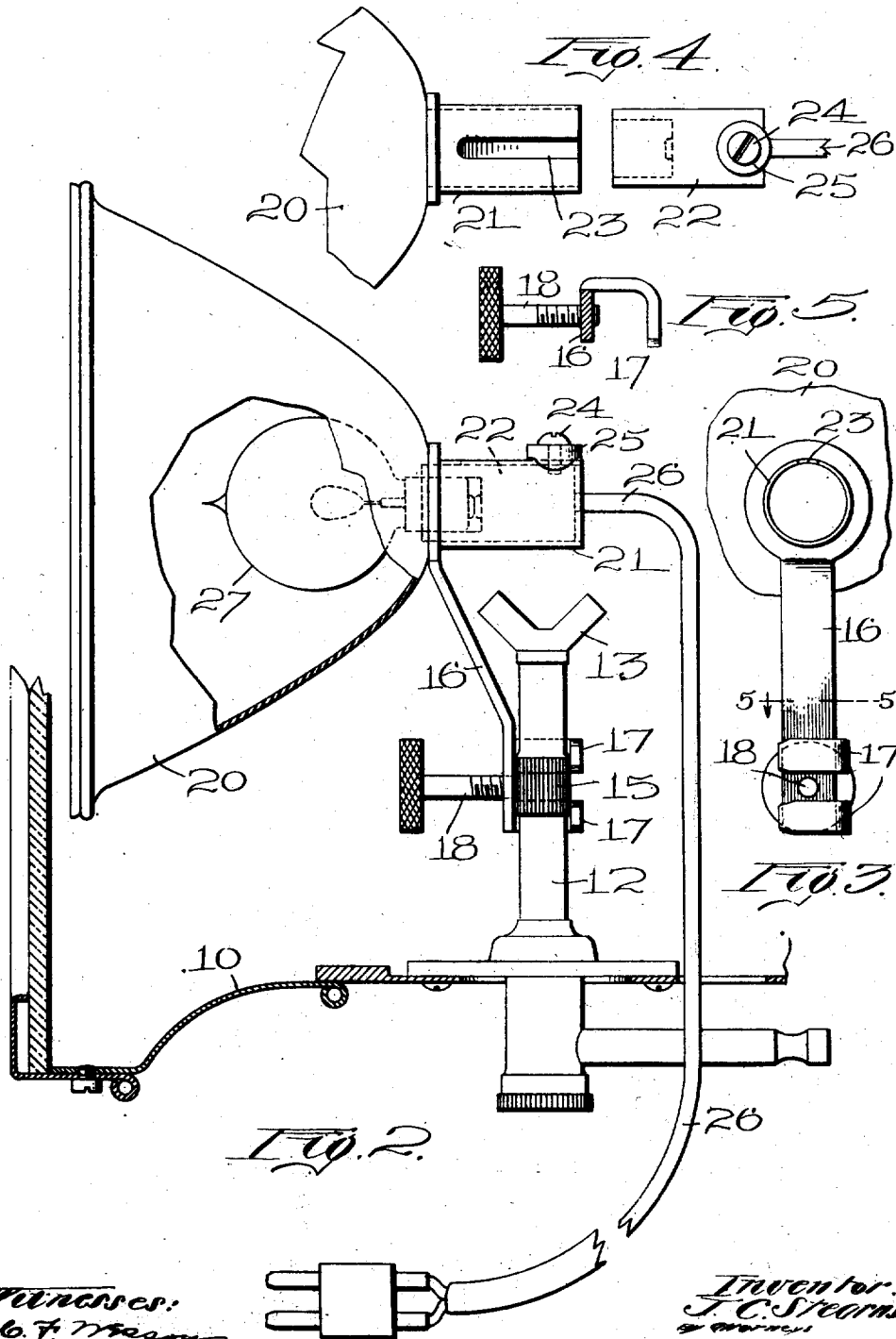

Witnesses:
 G. F. Mason
 E. W. Allen.

Inventor:
 J. C. Stearns
 South at Southgate

UNITED STATES PATENT OFFICE.

JASON C. STEARNS, OF WORCESTER, MASSACHUSETTS.

ELECTRIC-LIGHT ATTACHMENT FOR GAS-LAMPS.

974,930.

Specification of Letters Patent.

Patented Nov. 8, 1910.

Application filed January 31, 1910. Serial No. 541,059.

To all whom it may concern:

Be it known that I, JASON C. STEARNS, a citizen of the United States, residing at Worcester, in the county of Worcester and State of Massachusetts, have invented a new and useful Electric-Light Attachment for Gas-Lamps, of which the following is a specification.

This invention relates to a lamp, particularly adapted for use on automobiles and other vehicles, although the invention is capable of general use. On account of the desirability of changing the head-lights of automobiles from one form of lamp to another, particularly from an acetylene to an incandescent electric lamp, it has been proposed heretofore to provide an acetylene burner with a movable incandescent electric lamp adapted to be moved into and out of position in front of the reflector with which the acetylene lamp is ordinarily provided. This arrangement is open to objection however, on account of the fact that acetylene and other gas lamps cannot be provided with reflectors extending overhead, such as parabolic reflectors, because they would smoke up the upper side thereof. The reflectors usually employed for gas lamps are not as suitable for small incandescent lamps as parabolic reflectors would be, because they do not concentrate the rays sufficiently. This makes it necessary to use a high power incandescent lamp to get sufficient light for the desired purpose. On account of the irregular vibration to which these lamps are subjected when used on automobiles a movable electric lamp is objectionable as it is liable to be shaken out of place, particularly after the parts are considerably worn.

The principal objects of this invention are to provide means whereby without materially modifying the acetylene or other gas lamp ordinarily used, an incandescent electric lamp of comparatively small candle power can be used, and a reflector provided for it of such construction as to provide for efficiently concentrating the rays and throwing them directly forward; also to provide means whereby the incandescent lamp will be removably supported on the standard of the gas burner in fixed position so that the vibration of the vehicle will not jar it out of position; and to provide means whereby the incandescent lamp can be adjusted along the

axis of the reflector in which it is mounted so that the greatest efficiency of the reflector and lamp can be obtained.

Further objects and advantages of the invention will appear hereinafter.

Reference is to be had to the accompanying drawings, in which—

Figure 1 is a side view of an acetylene gas lamp of ordinary construction provided with an electric lamp in accordance with this invention; Fig. 2 is a central longitudinal sectional view of a portion of the casing of the lamp showing the interior parts chiefly in elevation; Fig. 3 is a rear elevation of a portion of the electric lamp attachment; Fig. 4 is a plan of a portion thereof showing the lamp socket removed from the reflector; and Fig. 5 is a sectional view on the line 5—5 of Fig. 3.

The invention is shown as applied to an acetylene gas lamp comprising a casing of ordinary construction provided with a reflector 11 at the back as is well understood in this art. Located entirely front of this reflector is the burner standard 12 on which is the acetylene gas tip 13. This burner is located as usual substantially at the focus of the reflector so as to secure the highest efficiency of the reflector. As has been stated, a reflector of a comparatively shallow construction is used and is located sufficiently far back from the burner to avoid smoking the upper part of the same.

The standard is shown as provided with a roughened or corrugated portion 15 on which is fixed a bracket 16, this bracket having claws 17 extending around back of the standard, and a screw 18 for rigidly fixing it thereto. The bracket extends forward and upward and is provided with a rigid parabolic reflector 20. This reflector is located above the acetylene burner and preferably extends forward substantially to the front of the lamp casing. At the rear of the reflector is a tubular projection 21 in which is mounted an incandescent electric lamp socket 22. This tubular projection is provided with a longitudinal slot 23 and the socket has a fastening screw 24 and a washer 25, the lower surface of which fits the tubular projection. Into this socket pass the electrical connections 26. The inner end of the socket is provided in a well known manner with screw threads for receiving

the incandescent lamp 27. It will be observed that in this way a reflector can be used for the electric lamp that is of the proper shape and size to secure a much higher efficiency than would be the case if it had to depend on the comparatively flat reflector 11 which is suitable for the acetylene flame. No reflector could be used for the latter of such form as to project over the top of the flame, and inclose it in such small space as that in which the parabolic reflector incloses the incandescent lamp. It is to be observed also that the reflector and incandescent lamp are rigidly supported on the standard so that the vibration, to which lamps of this kind are subjected when applied to automobiles and the like, will have no effect to dislodge the lamp or reflector from their proper position. In addition to these advantages it is to be observed that the electric lamp can be moved back and forth along the axis of the parabolic reflector so that it can be adjusted to proper position therein to give the maximum lighting efficiency.

While I have illustrated and described a preferred embodiment of the invention, I am aware that many modifications can be made therein by any person skilled in the art, and that the electric light attachment can be applied to other than acetylene gas lamps without departing from the scope of the invention as expressed in the claims. Therefore I do not wish to be limited to all the details of construction herein shown and described, but

What I do claim is:—

1. As an article of manufacture an acetylene gas burner, having a reflector behind the burner, a parabolic reflector located above said burner, and an incandescent electric lamp located within the parabolic reflector.

2. As an article of manufacture a gas burner comprising a standard, a reflector behind said burner, a parabolic reflector removably mounted on said standard in front of the first named reflector and over the burner, and an incandescent electric lamp located within the parabolic reflector.

3. As an article of manufacture a burner comprising a standard, a reflector behind the burner, a parabolic reflector located above said burner, an incandescent electric lamp located within the parabolic reflector, a bracket on which said parabolic reflector is

fixed, and means for removably attaching the bracket to the standard below the burner.

4. As an article of manufacture a burner having a fixed reflector located entirely behind said burner, an electric lamp removably mounted adjacent to the burner, and a second reflector removable with the electric lamp and extending above it and forward from it.

5. In a device of the class described, the combination of a gas burner having a standard, a bracket removably mounted on the standard and rigidly secured thereto, an incandescent electric lamp mounted on the bracket, and a reflector fixedly mounted on said bracket.

6. In a device of the class described, the combination of a burner, a bracket rigidly fixed thereto and extending upwardly therefrom, an incandescent electric lamp mounted on said bracket, and a reflector for said incandescent lamp removable from the burner with the bracket.

7. In a device of the class described, the combination of a burner having a standard provided with a corrugated surface, a bracket having claws adapted to engage said corrugated surface, a screw for fixing the bracket to the standard on said surface, said bracket extending upwardly, an incandescent electric lamp supported by said bracket above the top of the burner, electrical connections for the lamp extending from the rear of the bracket down past the burner, and a reflector for the incandescent lamp mounted on the bracket.

8. The combination with a burner, of a reflector mounted thereon, and an incandescent electric lamp adjustably supported in the reflector.

9. The combination with a burner, of a parabolic reflector rigidly mounted thereon, and an incandescent electric lamp adjustably supported by said reflector.

10. The combination with a burner, of a parabolic reflector rigidly mounted thereon, and an incandescent electric lamp supported in said reflector, and adjustable along the axis of said reflector.

In testimony whereof I have hereunto set my hand, in the presence of two subscribing witnesses.

JASON C. STEARNS.

Witnesses:

ALBERT E. FAY,
C. FORREST WESSON.