

June 14, 1927.

1,632,371

G. W. GILMAN

PENCIL

Filed Nov. 7, 1921

2 Sheets-Sheet 2

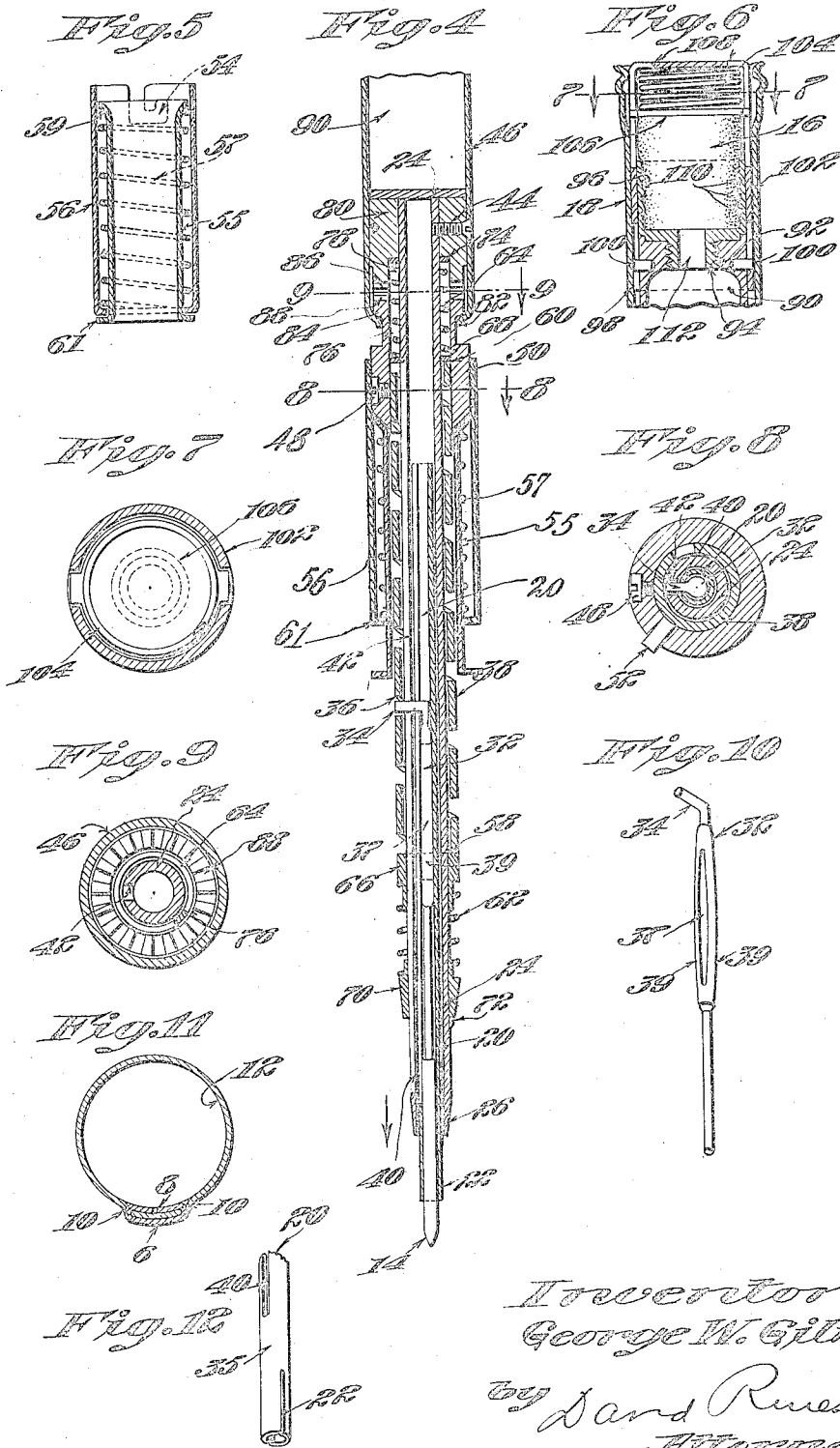

Inventor
George W. Gilman
by Sand Rues
Attorney

UNITED STATES PATENT OFFICE.

GEORGE W. GILMAN, OF ATTLEBORO, MASSACHUSETTS, ASSIGNOR, BY MESNE ASSIGNMENTS, TO THE PARKER PEN COMPANY, OF JANESVILLE, WISCONSIN, A CORPORATION OF WISCONSIN.

PENCIL.

Application filed November 7, 1921. Serial No. 513,226.

The present invention relates to marking devices, and more particularly to lead pencils provided with metal casings through which the lead is gradually advanced at will as it is used up.

In some types of pencils of the above-described character, the lead is advanced by a plunger between predetermined limits of feed movement through a feed mechanism that actuates the plunger in response to relative rotation of the feed mechanism and the plunger. At the limits of feed movement, the feed mechanism can not turn further relative to the plunger in the same direction, and persistent or accidental efforts to effect further rotation causes binding of the parts and, perhaps, destruction of some delicate mechanism.

It is therefore an object of the present invention to permit free relative rotation of the parts at both the limits of feed movement, so that the mechanism may be freely rotated at the said limits, without advancing or retracting the pencil, and without injuring any of the parts.

To this end, a feature of the invention resides in combining a relatively rotatable feed sleeve having a spiral thread adapted to engage a projection provided upon the marker-carrying plunger, the ends of the spiral thread being open, with yielding means at both ends of the sleeve between which and the sleeve the projection is permitted to ride at the limits of movement of the plunger during the free relative rotation of the sleeve at the said limits of movement.

Another object of the invention is to provide improved means for mounting the lead-carrying body within the pencil casing or for mounting the cap upon the lead-carrying body. The invention is not, of course, limited to the specific constructional details illustrated herein, but the preferred embodiment of the invention involves the use of a pin upon one element that is adapted to be maintained yieldingly within a hook that is provided upon another element to lock the elements yieldingly together.

Another feature of the invention contemplates novel means for rotatably connecting together two elements one of which is

locked in place against movement within the casing, the other element being adapted for rotation to cause the lead to be advanced at will. The elements are so connected together as to make possible their removal from the casing by manipulation of one element only.

Further objects of the invention are to improve upon the construction of the pencil-carrying plunger; to provide an improved clutching tube for clutching the plunger and the lead; and to provide an improved adjustable eraser.

Additional objects not enumerated above will be made clear by the following description, taken in connection with the accompanying drawings, and will be particularly pointed out in the appended claims, it being understood that the invention consists of the improved marking device illustrated and described, and that it is intended to set forth in the claims all the novelty that the invention disclosed may possess.

In the drawings, illustrating a preferred embodiment of the present invention, Fig. 1 is an elevation; Fig. 2 is a central longitudinal section taken through the casing and the cap substantially upon the line 2—2 of Fig. 1, looking in the direction of the arrows; Fig. 3 is a view of the body of the pencil with the casing and the cap removed; Fig. 4 is an enlarged central longitudinal section through the body of the pencil shown in Fig. 3; Fig. 5 is a view of a detail; Fig. 6 is a central longitudinal section through the cap and adjacent portions of the pencil; Figs. 7, 8 and 9 are transverse sections taken, respectively, substantially upon the lines 7—7 of Fig. 6 and 8—8 and 9—9 of Fig. 4, looking in the direction of the arrows, the clutch tube and the plunger being omitted from Fig. 9, for clearness; Fig. 10 is a view of a detail; Fig. 11 is a section taken upon the line 11—11 of Fig. 1 and Fig. 12 is a fragmentary perspective view of the clutch tube.

The pencil-carrying body, shown more particularly in Fig. 3, is housed in a casing 2 (Figs. 1 and 2). The pencil may be retained in the owner's pocket by a clip 6 having tongues 8, Figs. 2 and 11, extending through slots 10 and bent over against the

inner wall 12 of the casing. The lead or other marker 14 projects from the forward end of the casing and is gradually fed forward, as it is used up, by rotary feed mechanism hereinafter to be described. An eraser 16 at the other or rear end of the pencil is ordinarily protected against dirt and the like by a cap 18, but may be put into service when the cap is removed.

The lead 14 is frictionally clutched by a tube 20 through one end 22 of which it projects, as will be understood more particularly from Fig. 4. The tube 20 is slidingly mounted in a barrel 24. The end 26 of the barrel 24 is conical and rests against a correspondingly conically shaped inner wall 28 of the casing 2, as will be understood from Fig. 2. The end 22 of the clutch tube 20 normally projects beyond the end 26 of the barrel 24 and into engagement with the inner wall of the casing at 30. When the projecting end of the lead becomes used up, a fresh portion may be forced forward by a plunger 32, Fig. 4, that engages the other end of the lead. As the plunger is of about the same diameter as the lead, the clutch tube 20 frictionally clutches the plunger as well as the lead, but forward progress of the tube 20 is prevented by its engagement with the casing at a stop 30. Advancing the plunger, therefore, will result in the lead 14 being pushed forward through the clutch tube 20 in the direction of the arrow, Fig. 4. There is nothing, however, to prevent the rearward movement of the tube 20 within the barrel 24. Retracting the plunger, therefore, will result in the tube 20 that frictionally clutches it being retracted also, carrying the lead 14 with it. If the lead should be advanced too far by the forward movement of the plunger, therefore, all that is necessary is to retract the plunger, until just so much lead only projects from the casing as is desired. The lead may similarly be withdrawn into the casing to protect it against breakage when the pencil is not in use. The plunger may be advanced in the tube 20 up to the very end 22 of the tube, so that practically the very last tip of the lead 14 may be used up, for the clutch tube will continue to clutch the lead even though only a very small portion of it is left.

The end 22 of the tube 20 is forked to provide a resilient clutching effect upon the lead when only a very small portion of the lead is left. The other end of the tube is longitudinally slotted at 40 for a considerable distance to permit free sliding movement between the walls of the slot of a projection 34 that is provided upon the plunger. For a similar purpose, the barrel 24 is slotted at 42. The slot 40, furthermore, permits of squeezing or deforming the tube 20 to provide for the necessary degree of fric-

tional binding or clutching upon the lead and the plunger. To cause the tube to retain its resiliency, an intermediate portion 35 is uncut. The clutching action of the tube upon the plunger may be adjusted by intermediately slotting the plunger at 37 to provide resilient tongues 39. By pulling the tongues farther apart or forcing them nearer together, the plunger may be expanded or contracted at will. A very flexible tension is thus provided between the plunger and the walls of the clutch tube, for the tongues 39 may be adjusted so as to bind against the walls of the clutch tube with just the proper degree of tension. The clutch mechanism is thereby assured of a very long life.

The preferred mechanism for advancing and retracting the plunger will now be described. The projection 34 of the plunger is adapted to be engaged by a helical or spiral thread 36 upon a rotatable sleeve 38 that is mounted to enclose the barrel 24. As the sleeve is relatively rotated, therefore, the plunger will be advanced or retracted, according to the direction of rotation of the sleeve. The projection 34 will slide freely through the slots 40 and 42 in the clutch tube 20 and the barrel 24, respectively. It is therefore not possible to rotate either the clutch tube or the barrel without also rotating the plunger 32 in the tube 20. Owing to the spiral thread 36, and assuming that the sleeve 38 is stationary, the plunger can not rotate unless it is at the same time carried longitudinally forward or backward. To advance or retract the plunger, therefore, all that is necessary is to rotate the tube 20 or the barrel 24, at the same time holding the sleeve 38 against rotation. In the preferred construction, the barrel 24 is adapted to be manually rotated by securing it, as by means of a screw 44, Fig. 4, to a manually rotatable tube 46 projecting through the casing at the rear or eraser end of the pencil. Manual rotation of the tube 46, therefore, while the sleeve 38 is held stationary, will result in advancing or retracting the lead 14 at will. As will appear later, it will not be necessary to grasp the tube 46 in the hand for this purpose, as the cap 18 is secured to the tube, so that the lead 14 is advanced or retracted at will by rotating the cap in one or the other direction. The tube 46 is enlarged at 47 so as to fit better in the casing 2, as shown in Fig. 2.

To hold the spirally threaded sleeve 38 stationary during the rotation of the tube 46, it is fastened, as by a set screw 48, to a collar 50 that is provided with a projecting pin 52. The pin 52 is adapted to be engaged by a hook 54 that is provided upon a collar 56 that is frictionally or otherwise firmly mounted in the casing 2. A tube 55

is held in place in the collar 56, normally in the position of Fig. 5, by a spring 57. A flaring portion 59 of the tube 55 is adapted to be engaged by the collar 50, when the body of the pencil is forced into place in the casing, thereby forcing the tube 55, in opposition to the spring 57, to hold the pin 52 yieldingly in the hook 54. This hook-and-pin connection is all that holds the body of the pencil within its casing 2. The parts are yieldingly locked together against displacement by the spring 57.

Rotation of the tube 46 is thus adapted to effect the actuation of the lead 14 between predetermined limits of movement dependent upon the length of the sleeve 38. The pencil is thus adapted to hold originally a lead substantially equal in length to the length of the sleeve 38, and the projection 34 will travel the whole length of the spirally threaded sleeve 38 while advancing the lead throughout its length. At the limits of movement of the projection 34, near the ends of the sleeve, there would be a tendency for the spiral threads 36 to bind against the projection 34, causing injury, and perhaps destruction, of some delicate part of the mechanism. According to the present invention, however, this is prevented by preventing binding of the parts.

To the attainment of this result, the spiral thread is cut abruptly at both ends 58 and 60, and springs 62 and 64 yieldingly hold collars 66 and 68, respectively, in engagement with the ends of the sleeve 38. At the limits of movement of the projection 34, therefore, the projection rides off the open ends 58 and 60 of the spiral thread and into the space between the sleeve 38 and the collar 66 or the collar 68 as the case may be, compressing the corresponding spring 62 or spring 64. The tube 46 may thus be freely rotated at the limits of movement of the projection 34 without in any manner injuring the parts.

The spring 62 is confined between the collar 66 and a collar 70. The collar 70 is freely slidable upon the barrel 24 but its slidable movement is limited by a pin or projection 72 that is provided upon the barrel 24. The pressure of the collar 66 against the corresponding end 58 of the spirally threaded sleeve is thus rendered uniform, permitting the projection 34 to ride freely between the projection 66 and the sleeve 38 without causing greater tension in one position than in another.

Similar uniform tension is provided at the other end of the sleeve 38 by positioning the spring 64 between the collar or washer 68 and another collar or washer 74. The washers 68 and 74 and the spring 64 are held within opposed recesses 76 and 78, respectively formed in the collar 50 and a collar 80. The collar 80 is positioned between

the barrel 24 and the tube 46 and is secured to them in such intermediate position by the screw 44. The collars 50 and 80 are normally separated from each other, as shown in Fig. 4, and are maintained separated by the spring 64. Their detachment is, however, prevented by spinning at 82 the end of the tube 46 over against an annular shoulder 84 of the collar 50. By this arrangement, the tube 46, with the collar 80 and the barrel 24 secured thereto, is freely rotatable with respect to the collar 50 and the spirally threaded sleeve 38 that is fastened to the collar 50, but they nevertheless form a single unit the elements of which are not detachable one from the other.

When it is desired to have the sleeve 38 rotate with the tube 46, the tube 46 is first pressed forward towards the sleeve 38, in the direction of the straight arrow, Fig. 2. Clutch teeth 86 upon the collar 80 are thereupon forced into engagement with clutch teeth 88 upon the collar 50. So long as these teeth engage, rotation of the tube 46 will cause rotation of the sleeve 38 also. Further forward movement of the tube 46 in the direction of the straight arrow, Fig. 2, will cause the sleeve 36 to be pushed forward along with the tube 46, compressing the spring 62. The spring 64 is weaker than the spring 62, so that the former will yield first, to permit engagement of the clutch teeth 86 and 88 before the latter yield. Sufficient forward movement of the tube 46 and the sleeve 38, together with the parts carried thereby, in opposition to the springs 62 and 64, will cause the pin 52 to be moved away from the hook 54, Fig. 2, and a slight turning movement of the tube 46 at this time in the direction of the curved arrow, Fig. 2, will cause the pin 52 to become moved out of range of the hook 54. The pin 52, that is normally maintained in yieldingly locked position within the hook 54 by the spring 62, becomes thus freed from the hook and the body of the pencil, may then be readily removed from its casing, as shown in Fig. 3. The parts may be readily reassembled by reverse movements. The use of the spring 62 makes it unnecessary to manufacture the various parts with great precision, for any variations in size or shape from the standard will readily be compensated for by the spring and the parts will nevertheless be maintained snugly fitted together.

It will now be understood that the pencil-carrying body of the present invention comprises two relatively rotatable elements that are undetachably connected at 82; that one of these elements may be yieldingly locked in place within the casing through the hook-and-pin connection 52, 54; and that the other element may then be rotated, through manipulation of the tube 46, to cause the advance or retraction of the plun-

ger 32 and, therefore, of the lead 14. The elements are provided with normally yielding separated clutch faces that may be caused to engage to permit the removal of the body of the pencil from its casing.

Rearward of the collar 80, the tube 46 constitutes a chamber 90 for extra leads 14. Entrance to the chamber is by way of a screw-threaded opening 92, Fig. 6. The opening 92 is adapted to be plugged by a screw-threaded projection 94 provided upon the eraser cup 96. To insert or to remove leads, the eraser cup is unscrewed, thereby affording access to the lead chamber 90 through the opening 92.

Before the eraser cup 96 can be unscrewed, the cap 18 must be removed. The cap is very easily removed by a slight inward movement, in the direction of the straight arrow, Fig. 2, combined with a slight rotary movement in the direction of the curved arrow, Fig. 2, to effect the detachment of a hook 98, that is secured to the cap, from a pin 100 that is carried upon the body of the pencil. Any desired number of pins 100 and interengaging hooks 98 may be employed. As shown in Figs. 2, 3 and 6, two oppositely disposed pins 100 are preferred. These are adapted to be engaged by any opposite two of preferably four equiangularly arranged hooks 98 that are integral with a collar 102 that is rigidly secured to the interior of the cap. When it is desired to remove the cap, pressure is first applied in the direction of the straight arrow, in opposition to the force of a spring 104, a slight turning movement is given to the cap in the direction of the curved arrow to bring the projections or pins 100 out of range of the hooks, and the cap is then readily lifted off rearwardly. Reverse movements will cause the cap to be returned to its illustrated protective position, Figs. 2 and 6. The spring 104 is confined between a movable washer 106 and spun-over portions 108 of the collar 102, thus yieldingly maintaining the pins 100 within the hooks 98. With the cap in place, rotation of the cap will be communicated to the tube 46, thereby advancing or withdrawing the lead 14, at will.

The eraser cap is provided with a plurality of grooves 110 that the rubber of the eraser bites into to cause the eraser to be held firmly in place. When the eraser wears down, it may be adjusted by unscrewing the cup 96 and inserting a pin or other member through an opening 112 in the projection 94. The pin or other member will force the eraser any desired distance out of the cup to compensate for the wear. The rubber will again bite into the grooves 110 causing it to be held in place in its newly adjusted position.

Modifications will readily suggest themselves to persons skilled in the art, and all

such are considered to be included within the scope of the invention.

What is claimed as new is:

1. A device of the class described having, in combination, a marker plunger having a projection and adapted to be advanced and retracted between predetermined limits of movement, a sleeve having a spiral thread adapted to engage the projection to advance and retract the plunger according to the direction of relative rotation of the sleeve and the plunger, the ends of the spiral thread being open, and means at both ends of the sleeve adapted to yield to permit the projection to ride between the sleeve and the yielding means at the limits of movement of the plunger during the free relative rotation of the sleeve and the plunger at the said limits of movement, thereby to prevent binding of the parts at the said limits of movement.

2. A writing implement having, in combination, a marker plunger having a projection, a rotatable feed sleeve having a spiral thread adapted to engage the projection to advance and retract the plunger according to the direction of rotation of the sleeve, a collar mounted at each end of the feed sleeve, and springs interposed between the feed sleeve and the collars, the ends of the feed sleeve being open to permit the projection to ride between the sleeve and the springs to prevent binding of the parts when the projection is actuated to the ends of the feed sleeve.

3. A device of the class described having in combination, a casing having a stop, a marker plunger, a clutch tube adapted to bind frictionally against the marker and the plunger to clutch yieldingly the marker and the plunger, and means for advancing the plunger through the casing, thereby first causing to advance with it the tube clutching it and the marker clutched by the tube, until the tube engages the stop to prevent farther advance movement of the tube, and then causing the plunger to advance through the tube in opposition to the yielding clutching action of the tube against the plunger to advance the marker through the tube, the plunger being adapted to be retracted to retract the tube clutching it and the marker clutched by the tube, whereby the marker is adapted to be retracted into the casing.

4. A device of the class described having, in combination, a casing through one end of which a marker is adapted to project, a marker plunger having a projection, a slotted clutch tube adapted to bind frictionally against the marker and the plunger to clutch yieldingly the plunger and the marker, the projection extending through the slot of the tube, and a rotatable feed sleeve having a spiral thread adapted to engage the projection to advance and retract the plunger according to the direction of ro-

tation of the sleeve, whereby, when the feed sleeve is rotated in one direction, first the plunger is advanced through the casing, carrying with it the tube clutching it and the marker clutched by the tube, until the tube engages the said end of the casing and is held against further advance movement, and then the plunger is advanced through the tube in opposition to the yielding clutching action of the tube against the plunger to advance the marker through the tube and the said end of the casing, and when the feed sleeve is rotated in the opposite direction, the plunger, the tube clutching it and the marker clutched by the tube are retracted, carrying the marker into the casing.

5. A device of the class described having, in combination, a marker plunger, a clutch tube adapted to bind frictionally against marker and the plunger to clutch yieldingly the marker and the plunger, means for advancing the plunger, thereby causing to advance with it the tube clutching it and the marker clutched by the tube, means for preventing advance of the tube, whereby the plunger is adapted to be advanced through the tube in opposition to the yielding clutching action of the tube against the plunger to engage the marker and advance it through the tube, and means for adjusting the binding action of the tube upon the plunger to adjust the clutching action of the tube upon the plunger, the plunger-advancing means being reversible so as to retract the plunger, the tube clutching it and the marker clutched by the tube.

6. A device of the class described having, in combination, a casing through one end of which a marker is adapted to project, a marker plunger having a projection, a slotted clutch tube adapted to bind frictionally against the marker and the plunger to clutch yieldingly the marker and the plunger, the projection extending through the slot of the tube, a rotatable feed sleeve having a spiral thread adapted to engage the projection to advance and retract the plunger according to the direction of rotation of the sleeve, the plunger being expansible and contractible to adjust the binding action of the tube upon the plunger to adjust the clutching action of the tube, and means for preventing the advance of the tube, whereby the plunger is adapted to be advanced through the tube in opposition to the yielding clutching action of the tube against the plunger to engage the marker and advance it through the tube when the sleeve is rotated in one direction, and whereby the tube and the marker are retracted with the plunger when the sleeve is rotated in the opposite direction.

7. A writing implement having, in combination, two elements, one a marker-carrying body, and the other a casing within

which the marker-carrying body is adapted to be mounted and having an opening through which a marker carried by the marker-carrying body is adapted to project, one of the elements having a collar provided with a hook and the other element having a pin for locking the marker-carrying body within the casing, the collar having a member that is adapted to be engaged by the said other element, and a spring for holding the member in engagement with the said other element and the pin in yieldingly locked relation within the hook.

8. A writing implement having, in combination, a casing, a marker-carrying body comprising two relatively rotatable connected elements, one of the elements being positioned entirely in the casing, means for locking the said one element against movement in its position in the casing, means for rotating the other element to move the marker, and means for locking the two elements together to facilitate their removal from the casing as a unit.

9. A device of the class described having, in combination, a casing, a marker-carrying body comprising two relatively rotatable connected elements provided with normally yieldingly separated clutch faces, a hook-and-pin connection between the casing and one of the elements, means for yieldingly maintaining the pin within the hook to yieldingly lock the body within the casing, and means for rotating the other element to move the marker, the clutch faces being adapted to become engaged to permit turning of the body as a unit, thereby to permit separation of the body from the casing.

10. A device of the class described having, in combination, a marker plunger having a projection, a barrel within which the plunger is slidingly mounted having a longitudinal slot permitting free sliding movement of the projection between the walls of the slot, a sleeve enclosing the barrel having a spiral thread adapted to engage the projection to advance and retract the plunger according to the direction of relative rotation of the sleeve and the plunger, means rotatably connecting the sleeve and the barrel together, a casing within which the sleeve is locked against rotation, means projecting through the casing secured to the barrel for rotating the barrel, and means for locking the sleeve and the barrel and cause them to rotate together to facilitate their removal from the casing.

11. A writing implement having, in combination, a marker-carrying body, a casing within which the marker-carrying body is adapted to be mounted and having an opening through which a marker carried by the marker-carrying body is adapted to project, the casing having an interiorly disposed collar provided with a hook, the marker-

carrying body having a pin adapted to be engaged by the hook, a member within the collar adapted to be engaged by the marker-carrying body, and a spring for holding the member in yielding engagement with the marker-carrying body and the pin in yieldingly locked relation within the hook to yieldingly lock the marker-carrying body in the casing.

12. A device of the class described having, in combination, a marker plunger having a projection and adapted to be advanced and retracted between predetermined limits of movement, a sleeve having a spiral thread adapted to engage the projection to advance and retract the plunger according to the direction of relative rotation of the sleeve and the plunger, the ends of the spiral thread being open, and means at the end of the sleeve adapted to yield to permit the projection to ride between the sleeve and the yielding means at the limits of movement of the plunger during the free relative rotation of the sleeve and the plunger at the said limits of movement, thereby to prevent binding of the parts at the said limits of movement.

13. A mechanical pencil comprising a rotatable member and a non-rotatable member with a spiral slot in one of same and a longitudinal slot in the other, a lead holding member with a lug thereon to project through the said slots into the spiral slot, with means whereby the rotation of the rotatable member will cause the lead holding member to be projected forwardly or retracted, means whereby when the lead holding member has reached the limit of its stroke, either forwardly or rearwardly, the operative parts for driving the lead will be released from operative connections so the rotatable member may continue to rotate without binding of the parts.

14. A mechanical pencil with means for projecting and retracting the lead, comprising a rotatable member and a non-rotatable member, with means whereby the operation of the rotatable member will selectively project or retract the lead; means whereby when the lead has reached the limit of its stroke either forwardly or rearwardly, the rotatable member may continue to rotate without binding of the parts.

15. A mechanical pencil comprising a rotatable and a nonrotatable member, there being a spiral slot in one of said members and a longitudinal slot in the other; a lead holding member with a lug to engage in the aforesaid slots; means whereby the operation of the rotatable member will selectively project or retract the lead holding member; yielding means whereby when the lead holding member has reached the end of its stroke, either forwardly or rearwardly, it will be released from its operative connection and

urged toward the sleeve so that continued operation of the rotatable member will not cause binding of the parts.

16. A mechanical pencil comprising a rotatable member and a non-rotatable member, there being a spiral slot in one of said members, said slot being open at each of its ends and a longitudinal slot in the other member; a lead holding member provided with a lug to engage in the slots; means whereby the operation of the rotatable member will selectively project or retract the lead holding member; means whereby the lug on the lead holding member after it has passed out of the open spiral slot, will be yieldingly held in engagement with the end of the member provided with the said spiral slot.

17. In a pencil, a relatively rotatable feed sleeve having a spiral thread, a lead carrying plunger, a projection thereon which engages said spiral thread, the ends of said thread being open, and yielding means between which and the sleeve the projection is free to ride and by which it is urged toward the sleeve at the end of the movement of said plunger whereby there may be free relative rotation of the parts without binding.

18. A mechanical pencil comprising a rotatable member and a non-rotatable member, there being a spiral slot in one of said members and a longitudinal slot in the other, a lead holding plunger provided with a lug to engage in the said slots; means yieldingly closing said spiral slot automatically operated to release the lug on the plunger from the spiral slot when the plunger has reached the limit of its stroke, either forwardly or rearwardly.

19. In magazine pencils wherein is provided a holder with a lead guide, a plunger for feeding the leads, and a screw for moving the plunger forwardly and reversely; the combination with the plunger and screw of means effective at the end of the plunger's forward stroke for holding the plunger and screw in position for engagement upon reverse rotation of the screw while permitting the screw to rotate in the forward direction freely without projecting the plunger.

20. In magazine pencils wherein is provided a plunger and a feeding screw and a guide for the plunger; said screw adapted to operatively disconnect from the plunger when the plunger has completed its forward stroke, whereby free rotation of the screw in the forward direction is permitted at that time, of resilient means engaging the plunger at the forward limit of its stroke continuously tending to force the plunger into reverse rotation of the screw the plunger and screw will again be operatively connected.

21. In magazine pencils of the character wherein is provided a lead guide, a feeding

plunger operating in the guide, a tubular
feed screw for operating with the plunger
to feed it forwardly and reversely, said
plunger and said screw adapted to opera-
5 tively disengage when the plunger has been
fully advanced whereby forward feed rota-
tion of the feed screw will not effect a for-
ward adjustment of the plunger, a spring
pressed collar on the guide engaging a part
10 of the plunger when it reaches the forward
limit of its movement to force it toward the
screw and ensure engagement therewith
when the screw is reversely rotated.

22. In magazine pencils of the character
15 wherein is provided a lead guide, a feeding
plunger operating in the guide, a tubular
feed screw for operating with the plunger
to feed it forwardly and reversely, said

plunger and said screw adapted to opera-
tively disengage when the plunger has been 20
fully advanced whereby forward feed rota-
tion of the feed screw will not effect a for-
ward adjustment of the plunger, a spring
pressed collar on the guide engaging a part 25
of the plunger when it reaches the forward
limit of its movement, to force it toward the
screw and ensure engagement therewith
when the screw is reversely rotated, said
collar adapted to engage the end of said
30 screw and disengage the plunger after the
screw has been reversed and the plunger re-
tracted.

In testimony whereof, I have hereunto
subscribed my name this 3d day of Novem-
ber, 1921.

GEORGE W. GILMAN.