

May 6, 1952

T. ORNAS, JR

Des. 166,705

VEHICLE CAB

Filed Dec. 29, 1951

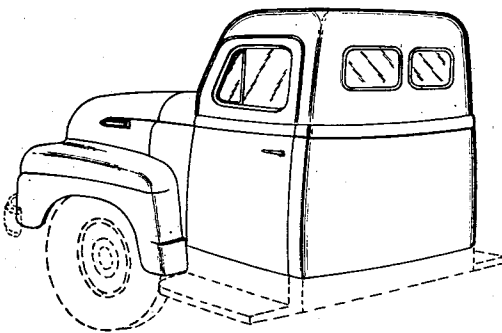
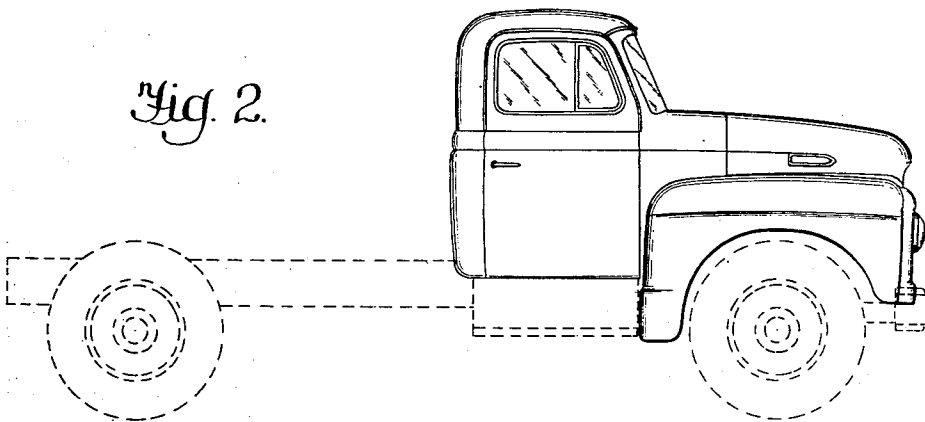
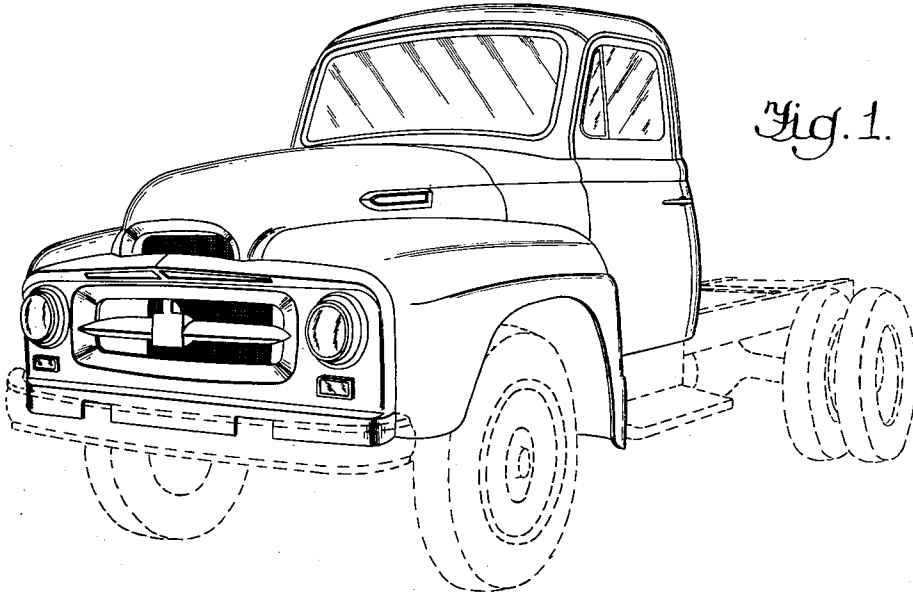

Fig. 3.

INVENTOR.  
Theodore Ornas, Jr.  
BY Paul O. Pippel  
Atty

# UNITED STATES PATENT OFFICE

166,705

## VEHICLE CAB

Theodore Ornas, Jr., Fort Wayne, Ind., assignor  
to International Harvester Company, a corporation  
of New Jersey

Application December 29, 1951, Serial No. 17,866

Term of patent 14 years

(Cl. D14—3)

*To all whom it may concern:*

Be it known that I, Theodore Ornas, Jr., a citizen of the United States, residing at Fort Wayne, in the county of Allen and State of Indiana, have invented a new, original, and ornamental Design for a Vehicle Cab, of which the following is a specification, reference being had to the accompanying drawings, forming part thereof, in which:

Figure 1 is a perspective view taken from one side of a vehicle cab, showing my new design;

Figure 2 is a side elevational view taken from the other side thereof; and

Figure 3 is a perspective view taken from a point disposed rearwardly of the cab.

The dot-dash lines shown in the several drawing figures are for illustrative purposes only.

I claim:

The ornamental design for a vehicle cab, substantially as shown and described.

THEODORE ORNAS, JR.

### REFERENCES CITED

The following references are of record in the file of this patent:

#### UNITED STATES PATENTS

Number	Name	Date
D. 166,041	Lee .....	Feb. 26, 1952

#### OTHER REFERENCES

Commercial Car Journal, February 1950, page 221.