

(19) World Intellectual Property Organization  
International Bureau



(43) International Publication Date  
16 February 2006 (16.02.2006)

PCT

(10) International Publication Number  
**WO 2006/016155 A1**

(51) International Patent Classification<sup>7</sup>: **E21B 17/10**

(21) International Application Number:  
PCT/GB2005/003137

(22) International Filing Date: 11 August 2005 (11.08.2005)

(25) Filing Language: English

(26) Publication Language: English

(30) Priority Data:  
0417937.0 12 August 2004 (12.08.2004) GB

(71) Applicant (for all designated States except US): **WIRE-LINE ENGINEERING LIMITED** [GB/GB]; Technology House, Blackburn Business Park, Balckburn, Aberdeen AB21 0PS (GB).

(72) Inventor; and

(75) Inventor/Applicant (for US only): **HALL, Robert, Neil** [GB/GB]; 8 Keir Heights, Balmedie, Aberdeen AB23 8WJ (GB).

(74) Agent: **MURGITROYD & COMPANY**; 165-169 Scotland Street, Glasgow G5 8PL (GB).

(81) Designated States (unless otherwise indicated, for every kind of national protection available): AE, AG, AL, AM, AT, AU, AZ, BA, BB, BG, BR, BW, BY, BZ, CA, CH, CN, CO, CR, CU, CZ, DE, DK, DM, DZ, EC, EE, EG, ES, FI, GB, GD, GE, GH, GM, HR, HU, ID, IL, IN, IS, JP, KE, KG, KM, KP, KR, KZ, LC, LK, LR, LS, LT, LU, LV, MA, MD, MG, MK, MN, MW, MX, MZ, NA, NG, NI, NO, NZ, OM, PG, PH, PL, PT, RO, RU, SC, SD, SE, SG, SK, SL, SM, SY, TJ, TM, TN, TR, TT, TZ, UA, UG, US, UZ, VC, VN, YU, ZA, ZM, ZW.

(84) Designated States (unless otherwise indicated, for every kind of regional protection available): ARIPO (BW, GH, GM, KE, LS, MW, MZ, NA, SD, SL, SZ, TZ, UG, ZM, ZW), Eurasian (AM, AZ, BY, KG, KZ, MD, RU, TJ, TM), European (AT, BE, BG, CH, CY, CZ, DE, DK, EE, ES, FI, FR, GB, GR, HU, IE, IS, IT, LT, LU, LV, MC, NL, PL, PT, RO, SE, SI, SK, TR), OAPI (BF, BJ, CF, CG, CI, CM, GA, GN, GQ, GW, ML, MR, NE, SN, TD, TG).

Published:  
— with international search report

For two-letter codes and other abbreviations, refer to the "Guidance Notes on Codes and Abbreviations" appearing at the beginning of each regular issue of the PCT Gazette.

(54) Title: DOWNHOLE DEVICE

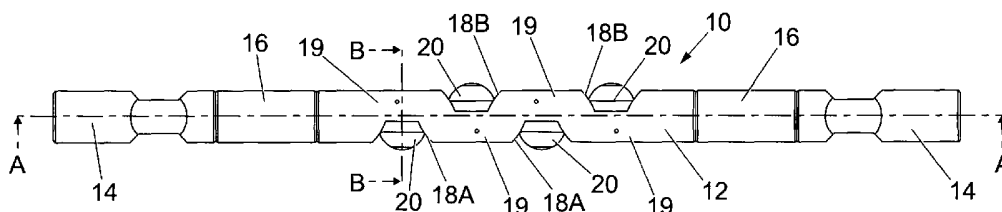

(57) Abstract: The invention relates to a downhole device for incorporation into a downhole string and movement in a wellbore. The device comprises a body member (12), at least one roller (20) arranged on the device to engage the inner surface of the wellbore and means to orient the device in the wellbore. The means to orient the device are provided on the or each roller. Preferably the means to orient the device comprise a projecting portion provided on the or each roller which projects radially outwardly from the body member. The projecting portion can be an eccentrically-shaped portion of the or each roller.



WO 2006/016155 A1

1 "Downhole Device"

2

3 This invention relates to a downhole device, and  
4 particularly but not exclusively a downhole device  
5 adapted for use in wireline or slickline  
6 applications.

7

8 In conventional wireline and slickline operations, a  
9 toolstring comprising different tools is lowered  
10 into casing, tubing or other tubulars in a borehole  
11 from a wire or cable spooled from a drum located at  
12 the surface of the wellbore. It is often necessary  
13 to perform wireline or slickline operations during  
14 for example completion, maintenance and servicing,  
15 installation and retrieval of downhole apparatus,  
16 intervention and well logging. Toolstrings often  
17 comprise one or more devices that collect data from  
18 the wellbore such as temperature, salinity etc of  
19 recovered fluids. In addition to suspending the  
20 string of tools, the wire or cable spooled from a  
21 drum may also act as a conduit for power required by  
22 the tools to carry out their functions in the

1 wellbore, and may include signal cables for  
2 conveying data gathered by downhole sensors back to  
3 the surface.

4  
5 Toolstrings operate satisfactorily in vertical and  
6 near vertical wells, but problems arise when they  
7 are used in deviated wells since contact between the  
8 outer diameter of the toolstring and the inner  
9 diameter of the wellbore casing or other tubular  
10 creates a frictional force which acts against the  
11 gravitational forces urging the toolstring downhole,  
12 and these frictional forces increase with the  
13 deviation of the well. In addition, as deviation  
14 increases, the string is more likely to snag on the  
15 casing connections or other raised surfaces on the  
16 inner wall of the casing or other tubular.

17  
18 Roller bogies incorporated into the toolstring to  
19 assist the movement of toolstrings within casing or  
20 other tubulars in such deviated wells are available;  
21 however, contortions throughout the length of the  
22 casing or other tubular, and in the toolstring  
23 itself, often results in the rollers of such  
24 conventional roller bogies failing to make contact  
25 with the inner diameter of the casing or tubular.  
26 This reduces or removes the effect of the roller  
27 bogie and can result in parts of the toolstring  
28 contacting the inner diameter of the casing or other  
29 tubular regardless of the provision of the roller  
30 bogie.

31

1 According to the present invention there is provided  
2 a downhole device for incorporation into a downhole  
3 string and movement in a well-bore, the device  
4 comprising:-

5 one body member;

6 at least one roller arranged on the device to  
7 engage the inner surface of the well-bore; and

8 means to orient the device in the well bore,  
9 the means to orient the device is provided on the or  
10 each roller.

11

12 Optionally, the means to orient the device comprises  
13 a projecting portion of the or each roller which  
14 projects from the body of the device in the  
15 direction of the axis of rotation of the or each  
16 roller by a distance at least equal to and  
17 preferably greater than the diameter of the or each  
18 roller.

19

20 When the dimension along the axis of rotation of the  
21 rollers of the device is larger than the diameter of  
22 the roller, a degree of eccentricity is provided on  
23 the device, in order to allow the device to assume a  
24 desirable orientation e.g. with the rollers in  
25 contact with the inner surface of the casing or  
26 other tubular in which it is run.

27

28 Optionally, the projecting portion of the or each  
29 roller is an eccentrically shaped portion of the or  
30 each roller. Typically, the eccentrically shaped  
31 portion comprises an oval shape which extends from

1 the outer diameter of the roller to the end of the  
2 projecting portion.

3

4 Alternatively, the means to orient the device is  
5 provided by the or each roller being offset from the  
6 longitudinal axis of the device such that the or  
7 each roller projects from the body of the device in  
8 the direction of the axis of rotation of the or each  
9 roller by a distance at least equal to and  
10 preferably greater than the diameter of the or each  
11 roller.

12

13 Typically, the or each roller comprises a running  
14 edge which extends around the outer circumference of  
15 the or each roller. Preferably, the running edge is  
16 shaped such that it matches the internal surface of  
17 the well bore in which the device is to be run.

18

19 Optionally, the or each roller is secured to the  
20 device via a pin which typically also provides an  
21 axis of rotation about which the or each roller may  
22 rotate.

23

24 Optionally, the or each roller is provided with  
25 rotational friction reducing means adapted to reduce  
26 the frictional forces created when the or each  
27 roller rotates about the axis of rotation.

28

29 Typically, the frictional reducing means comprises a  
30 bearing arrangement adapted to act between a portion  
31 of the or each roller and a portion of the pin.

32 Alternatively, the frictional reducing means

1 comprises a slip surface provided on a portion of  
2 the or each roller in abutment with a slip surface  
3 provided on a portion of the body member of the  
4 device.

5

6 Optionally, the friction reducing means may also  
7 provide an axis of rotation about which the or each  
8 roller may rotate.

9

10 Typically, the slip surfaces comprise a durable low  
11 friction material such as ceramic.

12

13 Optionally, a plurality of rollers are provided on  
14 opposing sides of the device. Alternatively, a  
15 plurality of rollers are alternately spaced along  
16 the device such that a roller is provided on one  
17 side of the device at a first location followed by  
18 another roller on the other side of the device at a  
19 second location followed by a another roller on the  
20 same side as the roller at the first location.

21 Typically, this alternation continues along the  
22 length of the device for the plurality of rollers.

23

24 Preferably, the or each rollers are provided in a  
25 recess provided in the body of the device.

26

27 Preferably, the device comprises at least a swivel  
28 device.

29

30 Optionally, a throughbore capable of housing at  
31 least an elongate member such as a cable or wire may

1 be provided along the body of the device, typically  
2 along the longitudinal axis of the device.

3

4 Embodiments of the present invention will now be  
5 described by way of example only with reference to  
6 the accompanying drawings, in which:-

7

8 Fig. 1a is a planer view of a first embodiment  
9 of the device in accordance with the present  
10 invention;

11 Fig. 1b is a transverse cross-sectional view of  
12 the device of Fig. 1a taken through the view A-  
13 A;

14 Fig. 1c is a cross-sectional view of a roller  
15 of the device of Fig. 1a taken through the view  
16 B-B;

17 Fig. 2a is a planer view of a second embodiment  
18 of the device in accordance with the present  
19 invention;

20 Fig. 2b is a transverse cross-sectional view of  
21 the device of Fig. 2a taken through the view A-  
22 A;

23 Fig. 2c is a cross-sectional view of a roller  
24 of the device of Fig. 2A taken through the view  
25 B-B; and

26 Fig. 3 is a cross-sectional view of a roller  
27 arrangement of a third embodiment of the device  
28 in accordance with the present invention.

29

30 Referring to Figs. 1a, 1b and 1c and according to a  
31 first embodiment of the present invention, the  
32 device comprises a downhole sub 10 having a body 12

1 provided with suitable connections 14 at either end  
2 in order to allow the downhole sub 10 to be attached  
3 into a string of wireline tools for e.g. well  
4 intervention or MWD operations etc. The connections  
5 14 may be conventional box and pin type connections  
6 or any other suitable connections as required to  
7 allow connection to rest of the string. Swivels 16  
8 are typically provided at each end of the body 12 in  
9 order to allow the downhole sub 10 to rotate  
10 independently of the connections 14, and hence the  
11 rest of the toolstring (not shown) in the casing or  
12 tubular (not shown) as will be described  
13 subsequently.

14

15 The body 12 of the downhole sub 10 comprises a  
16 substantially circular cross-sectioned cylindrical  
17 member (best shown in Fig. 1c) having a number of  
18 recesses 18 provided at intervals along the length  
19 of the body 12. Each recess 18 comprises an indent  
20 on one side of the body 12 and are staggered along  
21 the length of the body 12 such that a recess 18A is  
22 positioned on the left hand side of the body 12 and  
23 is followed by a recess 18B on the right hand side  
24 of the body 12 which in turn is followed by a recess  
25 18A on the left hand side of the body 12 and so on  
26 along the length of the body. The body 12 connects  
27 at either end to a pin 22 which is surrounded by a  
28 rotating collar 24 of the swivel 16. The rotating  
29 collar 24 of each swivel 16 is connected to the  
30 connections 14 in order to provide a rotational  
31 dislocation of the device 10 from the rest of the  
32 toolstring (not shown).

1 The staggered arrangement of recesses 18 provides a  
2 degree of flexibility in the sub 10 whilst  
3 maintaining sufficient structural integrity of the  
4 sub 10. As the sub 10 moves downhole it is able to  
5 flex at bridging locations 19 on the body 12 due to  
6 the lower bending resistance of the reduced cross-  
7 sectional area provided by recessed portions 18. In  
8 this regard it should be noted that although four  
9 recesses 18 are shown in the embodiment of Fig. 1a,  
10 1b and 1c, more or fewer recesses 18 may be  
11 provided, and the distance between the recesses 18  
12 can be increased or decreased such that the bending  
13 resistance of the body 12 may be altered during  
14 manufacture of the sub 10 as required for specific  
15 downhole situations.

16

17 Rollers 20 are housed within each recess 18 and  
18 project therefrom. Each roller 20 comprises an oval  
19 shaped rotating member having a machined running  
20 edge 26 (best shown in Fig. 1c) which circumscribes  
21 a portion of the circumference of the roller 20  
22 adjacent its equator. The running edge 26 may be  
23 machined during manufacture such that its outer  
24 circumference matches the inner circumference of the  
25 casing or other tubular in which the sub 10 is to  
26 operate.

27

28 Each roller 20 projects from the body 12 by a small  
29 amount, indicated by A in Fig. 1c, in the order of  
30 3-25mm adjacent the machined running edge 26 and by  
31 a greater amount, indicated by B in Fig. 1c, in the  
32 order of 5-30mm adjacent a securing pin 36. The

1 projection differential between distances A and B  
2 may be provided by an asymmetrically shaped roller  
3 20 which has a greater diameter across one axis than  
4 an axis perpendicular to that axis i.e. one half of  
5 a three dimensional oval roller 20 or a  
6 substantially uniformly dimensioned semi-spherical  
7 roller which has been offset from the body 12  
8 longitudinal axis by a sufficient amount to provide  
9 the required differential, or may simply be provided  
10 by a portion of the apparatus (such as the pin 36)  
11 extending by the distance B from the body 12. This  
12 gives the sub 10 a degree of asymmetry via the  
13 rollers 20.

14

15 In the embodiment shown in Figs. 1a, 1b and 1c a  
16 ball bearing cage 28 is provided in a cavity on the  
17 inside of each roller 20 and encloses a number of  
18 ball bearings 30 therein. The ball bearing cage 28  
19 has an outer race 32 in communication with the  
20 inside of the roller 20 and an inner race 34 in  
21 communication with the outside edge of the securing  
22 pin 36. The outer race 32 may be secured to the  
23 inside of the roller 20 or may simply form an  
24 interference fit therebetween. Likewise the inner  
25 race 34 may be secured to the pin 36 or may simply  
26 form an interference fit therebetween. The number  
27 of ball bearings 30 are housed within the  
28 circumference of the ball bearing cage 28.

29

30 The securing pin 36 secures each roller 20 to the  
31 body 12 by projecting through a throughbore 21 in  
32 the roller 20 and into an appropriately dimensioned

1 socket 23 in the body 12 such that the roller 20 is  
2 secured to the body 12. The pin 36 may be held in  
3 the socket 23 by a latching pin (not shown) which  
4 can be inserted into detent 23a provided between the  
5 pin 36 and the socket 23 bore. In order to ensure  
6 that the rollers 20 are not prevented from rotating  
7 by the securing action of the securing pin 36, a  
8 spacer 38 is provided between the ball bearing cage  
9 28 and the recess 18 on the body 12 such that the  
10 roller 20 is secured to the body 12 but does not  
11 abut thereagainst.

12

13 Operation of the first embodiment of the downhole  
14 sub 10 will now be described.

15

16 When the toolstring (not shown) is fed downhole from  
17 the surface, the sub 10 is incorporated into the  
18 toolstring by connecting it thereto at connections  
19 14 such that the downhole sub 10 is integrated into  
20 the toolstring. The toolstring including the  
21 downhole sub 10 is then progressed into a downhole  
22 tubular such as wellbore casing (not shown). When  
23 the portion of the toolstring comprising the sub 10  
24 approaches a deviated section of the wellbore, the  
25 downhole sub 10 will tend to drift towards one side  
26 of the internal diameter of the casing due to the  
27 deviation thereof. Depending upon the initial  
28 orientation of the downhole sub 10 within the casing  
29 as it approaches the internal diameter of the  
30 casing, one of the machined running edge 26, the  
31 head of the pin 36 and a portion of the roller 20  
32 therebetween will contact the inner diameter of the

1 casing. Similar contact will occur at each of the  
2 rollers 20 along the length of the downhole sub 10.

3

4 If the orientation of the downhole sub 10 is such  
5 that the machined running edge 26 makes initial  
6 contact with the inner diameter of the casing then  
7 the downhole sub 10 will tend to run along the edges  
8 26 and thereby ensure minimal frictional resistance  
9 between the downhole sub 10 and the inner diameter  
10 of the casing.

11

12 In the event that the initial orientation of the  
13 downhole sub 10 is such that the first portion of  
14 the downhole sub 10 to contact the inner diameter of  
15 the casing is either the outer end of the pin 36 or  
16 a curved portion of the roller 20 between the outer  
17 end of the pin 36 and the machined running edge 26,  
18 the asymmetry of the rollers 20 projecting from the  
19 body 12 will tend to cause the sub 10 to rotate  
20 (this is possible due to the provision of swivels 16  
21 at either end of the sub 10) until the machined  
22 running edge 26 of the roller 20 comes into contact  
23 with the bottom of the casing. Therefore regardless  
24 of the initial rotational orientation of the sub 10  
25 is as it approaches the inner diameter of a deviated  
26 portion of the casing, the asymmetrical nature of  
27 the rollers 20 will ensure that the sub 10 and hence  
28 the toolstring is able to move through the casing  
29 with minimal frictional resistance.

30

31 A number of subs 10 may be incorporated along the  
32 length of the toolstring in order to allow each sub

1 10 to assume the correct orientation for that  
2 particular location in the deviated wellbore. This  
3 is possible due to the rotational dislocation  
4 between the orientation of the sub 10 and the rest  
5 of the toolstring (not shown).

6  
7 It should be noted that in this embodiment the  
8 rollers 20 are able to freely rotate independent of  
9 one another due to the movement of the toolstring  
10 and hence the sub 10 in the casing. The rotation of  
11 rollers 20 is assisted by the ball bearing  
12 arrangement 28, 30. As each roller 20 attempts to  
13 rotate around the pin 36 the internal circumference  
14 of outer race 32 rotates ball bearing 30 which acts  
15 against the outer circumference of inner race 34.  
16 This action allows the roller 20 to rotate around  
17 the pin 36 with minimal frictional resistance.

18  
19 Referring to Figs. 2a, 2b and 2c a second embodiment  
20 of a downhole sub will now be described. It should  
21 be noted that the second embodiment shares many  
22 common features with the first embodiment and where  
23 applicable these features have been referred to in  
24 the following description with similar numerals. A  
25 prefix 1 has been given to apparatus where this  
26 applies.

27  
28 The downhole sub 110 of Fig. 2 is provided with  
29 indents 118 on either side of the body 112 in order  
30 to accommodate rollers 120 on each side of the body  
31 112. This embodiment provides greater support for  
32 the downhole sub 10 on rollers 120 and hence the

1 toolstring to which it is attached (not shown) since  
2 fewer portions of the downhole sub 10 are  
3 unsupported by rollers 120. In addition the  
4 arrangement of rollers e.g. four on each side of the  
5 sub 110 results in the sub 110 having fewer points  
6 at which the body 112 of the sub 110 may contact the  
7 inner diameter of the casing or other tubular in  
8 which the sub 110 is run.

9  
10 Referring to Fig. 2c, each roller 120 is secured to  
11 the body 112 by a pair of interlocking pins 40, 42  
12 which project through a throughbore 121 on each  
13 roller 120 and the centre of the body 112 in order  
14 to engage with one another and thereby secure the  
15 rollers 120 to the body 112 and also provide an axis  
16 of rotation about which the rollers 120 may rotate.

17  
18 The required asymmetry of the sub 110 may be  
19 provided by an asymmetrically shaped roller which  
20 has a greater diameter across one axis than an axis  
21 perpendicular to that axis i.e. an oval shaped  
22 roller or as shown in Fig. 2c a substantially  
23 uniformly dimensioned semi-spherical roller which  
24 has been offset from the body 12 longitudinal axis  
25 by a sufficient amount to provide the required  
26 difference in the cross-sectional shape of the body  
27 112. In this regard it should be noted that the  
28 interengagement between pins 40 and 42 is arranged  
29 such that the overall dimension of the sub 110 is  
30 greater along the axis of rotation of the rollers  
31 120 than the circumference of the rollers 120.  
32 Alternatively the asymmetry may simply be provided

1 by a portion of the apparatus (such as pins 40, 42)  
2 extending from the body 112.

3

4 The various other components of the apparatus 110 of  
5 the second embodiment are substantially the same as  
6 those previously described in relation to the first  
7 embodiment and therefore will not be described any  
8 further.

9

10 In operation, the ball bearing arrangement provided  
11 by ball bearings 130 and ball bearing cage 128 of  
12 the sub 110 allows the rollers 120 to rotate about  
13 the interlocking pins 40, 42 whilst ensuring minimal  
14 frictional forces there between. In this embodiment  
15 the rollers 120 may move independently of one  
16 another which may be beneficial when e.g.  
17 discontinuities in the internal diameter of the  
18 casing are encountered i.e. one roller may rotate  
19 whilst the other does not.

20

21 Referring to Fig. 3 a third embodiment of a downhole  
22 sub will now be described. Again, it should be  
23 noted that the third embodiment shares many common  
24 features with the first embodiment and where  
25 applicable these features have been referred to in  
26 the following description with similar numerals. A  
27 prefix 2 has been given to apparatus where this  
28 applies.

29

30 Referring to Fig. 3 a further alternative embodiment  
31 of the downhole sub 210 is shown whereby the rollers  
32 220 are secured to the body 212 by securing studs 44

1 on each side of the body 212. The securing studs 44  
2 secure each roller 220 to the body by way of a  
3 threaded socket 46 in the body 212. In this way the  
4 centre of the downhole sub 210 is left free from  
5 obstructions and a central throughbore 48 can  
6 therefore be provided along the length of the  
7 downhole sub 210. The throughbore 48 may be used to  
8 house cables such as power or data cables (not  
9 shown) which are often necessary to provide a  
10 communication means along the length of the  
11 toolstring.

12

13 The embodiment shown in Fig. 3 may be used with a  
14 ball bearing cage similar to that described in  
15 relation to the first and second embodiments;  
16 however, due to the limited space available in the  
17 body 212 caused by providing throughbore 48 in the  
18 body 212 it is preferable to provide alternative  
19 means to assist the rotation of the rollers 220  
20 around the pins 44 as shown in Fig.3. Suitable  
21 alternative means comprise an inner slip surface 50  
22 provided on a projecting shoulder 54 of the body 212  
23 which abuts against an outer slip surface 52  
24 provided on an inner cavity of each roller 220. The  
25 inner and outer slip surfaces 50, 52 are made of a  
26 suitable material such that the abutment between  
27 each slip surface 50, 52 is conducive to rotation of  
28 the rollers 220 around the projecting stud 54, i.e.  
29 the material on the surfaces 50, 52 is made of a  
30 suitable low frictional resistance material such as  
31 ceramic in order to cause minimal frictional

1 resistance due to rotation of the rollers 220  
2 relative to the body 212.

3

4 The various other components of the apparatus 210 of  
5 the third embodiment are substantially the same as  
6 those previously described in relation to the first  
7 embodiment and therefore will not be described any  
8 further.

9

10 In each embodiment previously described the distance  
11 (indicated by A in Fig. 1c) by which the rollers 20,  
12 120 and 220 project from the respective body  
13 portions 12, 112 and 212 is manufactured such that  
14 the rollers may wear down during their operational  
15 lifetime without being worn down to such an extent  
16 that they are flush with the body 12, 112, 212 since  
17 this would cause the body portions to contact the  
18 inner diameter of the casing or other tubular.

19

20 Since the asymmetrical arrangement of the rollers in  
21 the embodiments described orientates the downhole  
22 sub in order that the running edge of the rollers  
23 engage the inner surface of the wellbore casing,  
24 this mitigates the possibility that the rollers fail  
25 to engage the inner surface of the wellbore casing  
26 by for instance the downhole sub resting on a  
27 portion not provided with rollers. This allows the  
28 sub to operate in highly deviated wells.

29

30 Modifications and improvements may be incorporated  
31 without departing from the scope of the invention,  
32 for example; further tools and/or subs such as

1 inclination sensors, vibrators etc. may also be  
2 provided on the downhole subs previously described.  
3 In addition, drive motors may be provided to rotate  
4 the rollers when the deviation in the wellbore is  
5 large enough to prevent gravity alone progressing  
6 the downhole sub down the casing or other tubular.  
7

## 1 CLAIMS

2

3 1. A downhole device for incorporation into a  
4 downhole string and movement in a well-bore, the  
5 device comprising:-

6 a body member;

7 at least one roller arranged on the device to  
8 engage the inner surface of the well-bore; and

9 means to orient the device in the well bore,  
10 wherein the means to orient the device is provided  
11 on the or each roller.

12

13 2. A downhole device according to claim 1, wherein  
14 the means to orient the device comprise a projecting  
15 portion of the or each roller which projects  
16 radially outwardly from the body member.

17

18 3. A downhole device according to claim 2, wherein  
19 the projecting portion projects in the direction of  
20 an axis of rotation of the or each roller.

21

22 4. A downhole device according to claim 3, wherein  
23 the dimension along the axis of rotation of the  
24 rollers of the device is larger than the diameter of  
25 the roller perpendicular to the axis of rotation.

26

27 5. A downhole device according to any of claims 2  
28 to 4, wherein the projecting portion of the or each  
29 roller is an eccentrically shaped portion of the or  
30 each roller.

31

1     6.    A downhole device according to claim 5, wherein  
2     the eccentrically shaped portion comprises an oval  
3     shape which extends from the outer diameter of the  
4     roller to the end of the projecting portion.

5

6     7.    A downhole device according to any preceding  
7     claim, wherein the means to orient the device is  
8     provided by the or each roller being offset from the  
9     longitudinal axis of the device such that the or  
10    each roller projects from the body of the device in  
11    the direction of the axis of rotation of the or each  
12    roller.

13

14    8.    A downhole device according to any preceding  
15    claim, wherein the or each roller comprises a  
16    running edge which extends around an outer  
17    circumference of the or each roller.

18

19    9.    A downhole device according to claim 8, wherein  
20    the running edge is shaped such that it matches the  
21    internal surface of the well bore in which the  
22    device is to be run.

23

24    10.   A downhole device according to any preceding  
25    claim, wherein the or each roller is secured to the  
26    device via a pin which provides an axis of rotation  
27    about which the or each roller may rotate.

28

29    11.   A downhole device according to any preceding  
30    claim, wherein the or each roller is provided with  
31    rotational friction reducing means adapted to reduce

1 the frictional forces created when the or each  
2 roller rotates about the axis of rotation.

3

4 12. A downhole device according to claim 11,  
5 wherein the friction reducing means comprises a  
6 roller bearing arrangement adapted to act between a  
7 portion of the or each roller and a portion of the  
8 pin.

9

10 13. A downhole device according to claim 11,  
11 wherein the friction reducing means comprise a slip  
12 surface provided on a portion of the or each roller  
13 in abutment with a slip surface provided on a  
14 portion of the body member of the device.

15

16 14. A downhole device according to claim 13,  
17 wherein the friction reducing means provide an axis  
18 of rotation about which the or each roller are  
19 rotatable.

20

21 15. A downhole device according to claim 13 or  
22 claim 14, wherein the slip surfaces comprise a  
23 durable low friction material.

24

25 16. A downhole device according to any preceding  
26 claim, wherein a plurality of rollers are provided  
27 on opposing sides of the device.

28

29 17. A downhole device according to claim 16,  
30 wherein the plurality of rollers are alternately  
31 spaced on opposing sides along the length of the  
32 device.

1

2 18. A downhole device according to any preceding  
3 claim, wherein the or each roller is provided in a  
4 recess provided in the body member of the device.

5

6 19. A downhole device according to any preceding  
7 claim, wherein the device comprises at least one  
8 swivel device arranged to allow rotation of the body  
9 member.

10

11 20. A downhole device according to any preceding  
12 claim, wherein a throughbore capable of housing at  
13 least one elongate member is provided within the  
14 body member of the device.

15

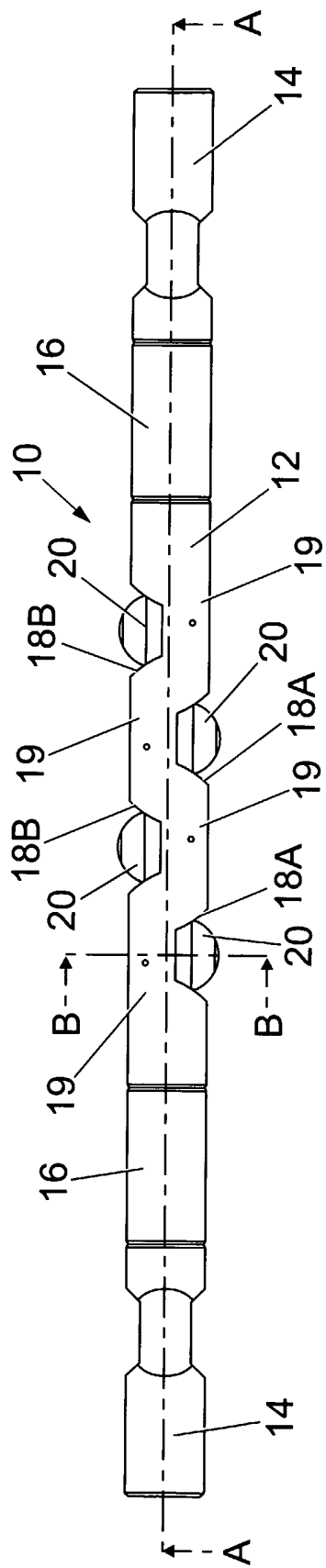

Fig. 1a

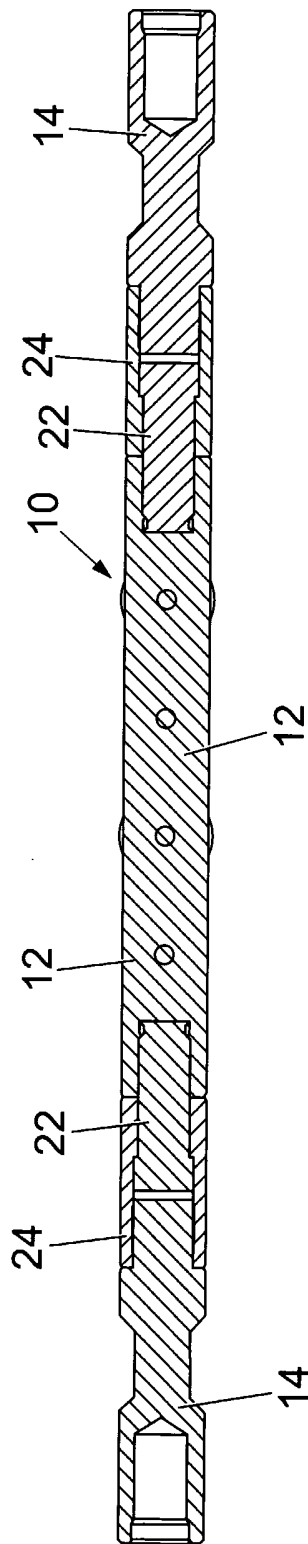
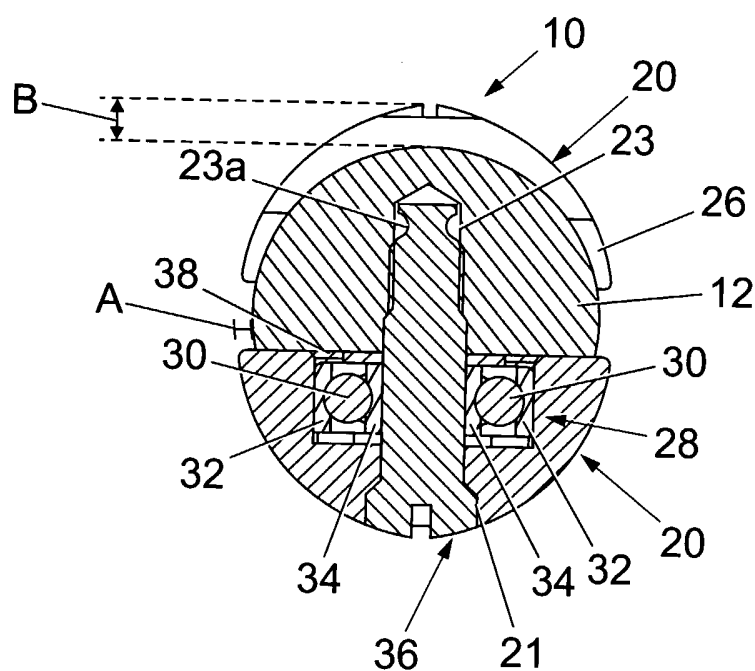

Fig. 1b



*Fig. 1c*

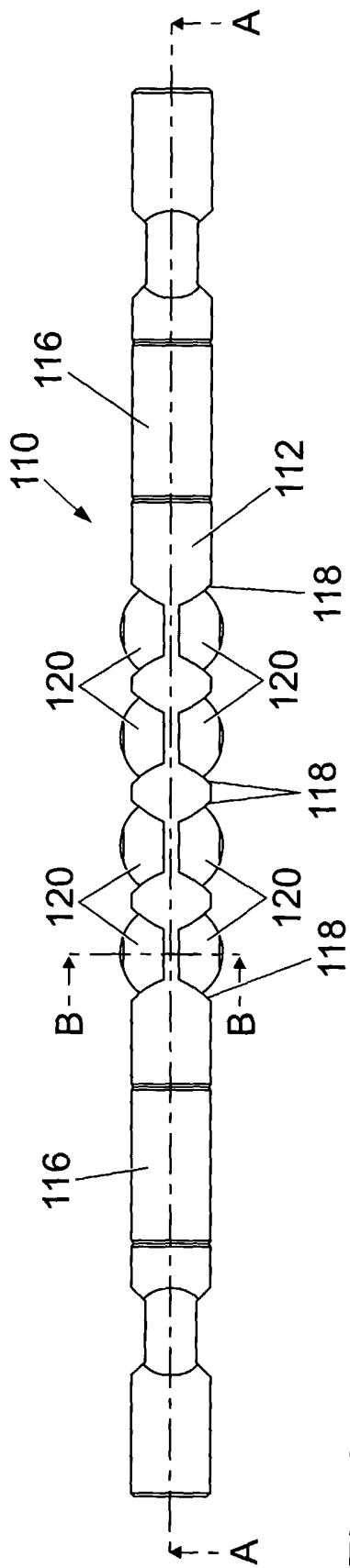

Fig. 2a

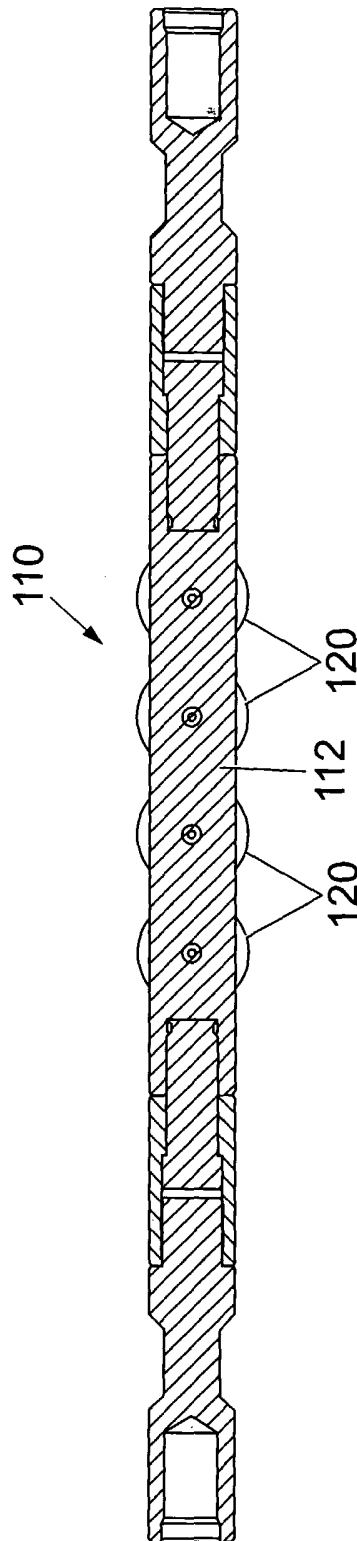
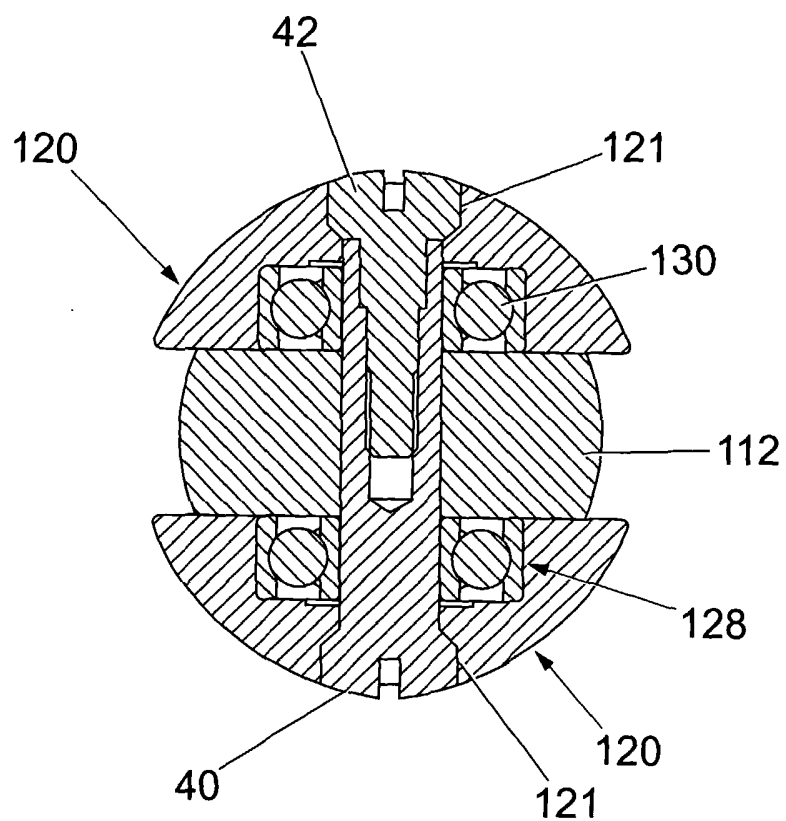

Fig. 2b



*Fig. 2c*

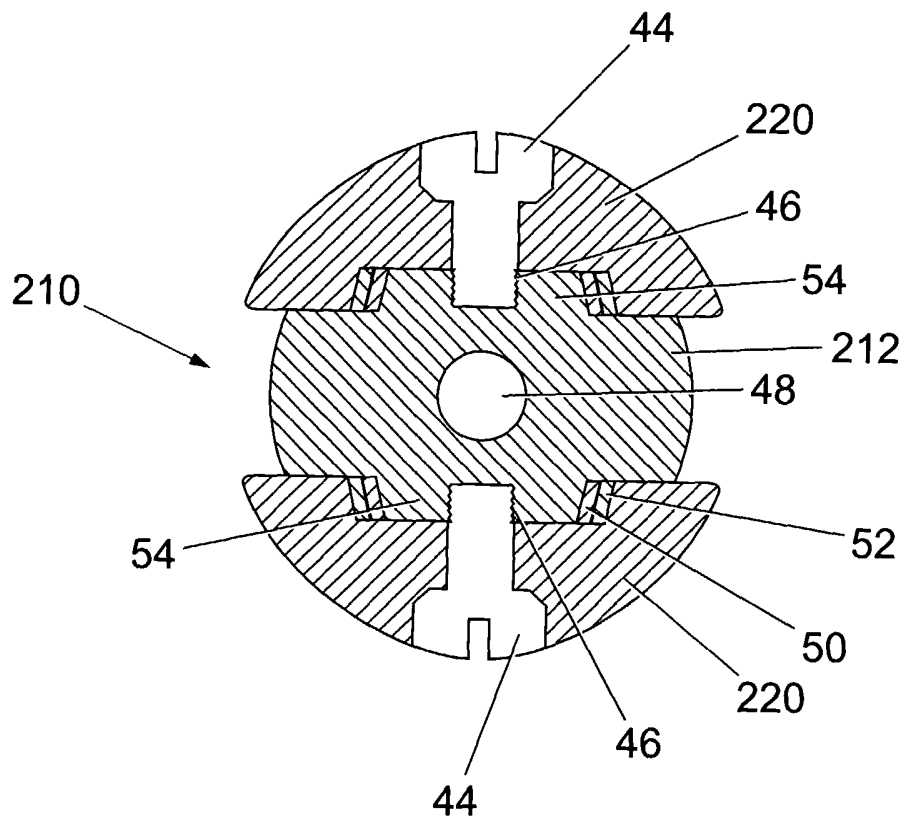

Fig. 3

# INTERNATIONAL SEARCH REPORT

International Application No  
PCT/GB2005/003137

<b>A. CLASSIFICATION OF SUBJECT MATTER</b> IPC 7 E21B17/10				
According to International Patent Classification (IPC) or to both national classification and IPC				
<b>B. FIELDS SEARCHED</b>				
Minimum documentation searched (classification system followed by classification symbols) IPC 7 E21B				
Documentation searched other than minimum documentation to the extent that such documents are included in the fields searched				
Electronic data base consulted during the international search (name of data base and, where practical, search terms used)  EPO-Internal				
<b>C. DOCUMENTS CONSIDERED TO BE RELEVANT</b>				
Category °	Citation of document, with indication, where appropriate, of the relevant passages	Relevant to claim No.		
X	US 2003/075321 A1 (HALL ROBERT NEIL) 24 April 2003 (2003-04-24)  paragraphs '0001!, '0003!; figures 3,4b,5c last sentence , paragraph 14 last sentence , paragraph 26 sentences 3,4, paragraph 38 last sentence , paragraph 39	1,2, 7-11,16, 18-20		
A	US 4 620 802 A (HARREL ET AL) 4 November 1986 (1986-11-04) figures 1,4	1-20		
A	CA 1 231 866 A1 (RED WING TOOL CO. LTD) 26 January 1988 (1988-01-26) figures 1,2	1-20		
<input type="checkbox"/> Further documents are listed in the continuation of box C.				
<input checked="" type="checkbox"/> Patent family members are listed in annex.				
° Special categories of cited documents :				
<table style="width: 100%; border: none;"> <tr> <td style="width: 50%; border: none; vertical-align: top;"> <ul style="list-style-type: none"> <li>*A* document defining the general state of the art which is not considered to be of particular relevance</li> <li>*E* earlier document but published on or after the international filing date</li> <li>*L* document which may throw doubts on priority claim(s) or which is cited to establish the publication date of another citation or other special reason (as specified)</li> <li>*O* document referring to an oral disclosure, use, exhibition or other means</li> <li>*P* document published prior to the international filing date but later than the priority date claimed</li> </ul> </td> <td style="width: 50%; border: none; vertical-align: top;"> <ul style="list-style-type: none"> <li>*T* later document published after the international filing date or priority date and not in conflict with the application but cited to understand the principle or theory underlying the invention</li> <li>*X* document of particular relevance; the claimed invention cannot be considered novel or cannot be considered to involve an inventive step when the document is taken alone</li> <li>*Y* document of particular relevance; the claimed invention cannot be considered to involve an inventive step when the document is combined with one or more other such documents, such combination being obvious to a person skilled in the art.</li> <li>*&amp;* document member of the same patent family</li> </ul> </td> </tr> </table>			<ul style="list-style-type: none"> <li>*A* document defining the general state of the art which is not considered to be of particular relevance</li> <li>*E* earlier document but published on or after the international filing date</li> <li>*L* document which may throw doubts on priority claim(s) or which is cited to establish the publication date of another citation or other special reason (as specified)</li> <li>*O* document referring to an oral disclosure, use, exhibition or other means</li> <li>*P* document published prior to the international filing date but later than the priority date claimed</li> </ul>	<ul style="list-style-type: none"> <li>*T* later document published after the international filing date or priority date and not in conflict with the application but cited to understand the principle or theory underlying the invention</li> <li>*X* document of particular relevance; the claimed invention cannot be considered novel or cannot be considered to involve an inventive step when the document is taken alone</li> <li>*Y* document of particular relevance; the claimed invention cannot be considered to involve an inventive step when the document is combined with one or more other such documents, such combination being obvious to a person skilled in the art.</li> <li>*&amp;* document member of the same patent family</li> </ul>
<ul style="list-style-type: none"> <li>*A* document defining the general state of the art which is not considered to be of particular relevance</li> <li>*E* earlier document but published on or after the international filing date</li> <li>*L* document which may throw doubts on priority claim(s) or which is cited to establish the publication date of another citation or other special reason (as specified)</li> <li>*O* document referring to an oral disclosure, use, exhibition or other means</li> <li>*P* document published prior to the international filing date but later than the priority date claimed</li> </ul>	<ul style="list-style-type: none"> <li>*T* later document published after the international filing date or priority date and not in conflict with the application but cited to understand the principle or theory underlying the invention</li> <li>*X* document of particular relevance; the claimed invention cannot be considered novel or cannot be considered to involve an inventive step when the document is taken alone</li> <li>*Y* document of particular relevance; the claimed invention cannot be considered to involve an inventive step when the document is combined with one or more other such documents, such combination being obvious to a person skilled in the art.</li> <li>*&amp;* document member of the same patent family</li> </ul>			
Date of the actual completion of the international search	Date of mailing of the international search report			
8 November 2005	21/11/2005			
Name and mailing address of the ISA European Patent Office, P.B. 5818 Patentlaan 2 NL - 2280 HV Rijswijk Tel. (+31-70) 340-2040, Tx. 31 651 epo nl, Fax: (+31-70) 340-3016	Authorized officer  Georgescu, M			

# INTERNATIONAL SEARCH REPORT

International Application No  
PCT/GB2005/003137

Patent document cited in search report	Publication date	Patent family member(s)	Publication date
US 2003075321 A1	24-04-2003	AU 1870801 A	12-06-2001
		CA 2392451 A1	07-06-2001
		EP 1234091 A1	28-08-2002
		WO 0140615 A1	07-06-2001
		GB 2374623 A	23-10-2002
US 4620802 A	04-11-1986	NONE	
CA 1231866 A1	26-01-1988	NONE	