

(19) World Intellectual Property Organization  
International Bureau



(43) International Publication Date  
2 April 2009 (02.04.2009)

PCT

(10) International Publication Number  
**WO 2009/041874 A1**

(51) International Patent Classification:  
*G02B 6/42* (2006.01) *G02B 6/38* (2006.01)

(74) Agent: **OLSSON, Gunnar**; Åsebackevägen 18, S-427 36  
Billdal (SE).

(21) International Application Number:  
PCT/SE2008/000526

(81) Designated States (unless otherwise indicated, for every kind of national protection available): AE, AG, AL, AM, AO, AT, AU, AZ, BA, BB, BG, BH, BR, BW, BY, BZ, CA, CH, CN, CO, CR, CU, CZ, DE, DK, DM, DO, DZ, EC, EE, EG, ES, FI, GB, GD, GE, GH, GM, GT, HN, HR, HU, ID, IL, IN, IS, JP, KE, KG, KM, KN, KP, KR, KZ, LA, LC, LK, LR, LS, LT, LU, LY, MA, MD, ME, MG, MK, MN, MW, MX, MY, MZ, NA, NG, NI, NO, NZ, OM, PG, PH, PL, PT, RO, RS, RU, SC, SD, SE, SG, SK, SL, SM, ST, SV, SY, TJ, TM, TN, TR, TT, TZ, UA, UG, US, UZ, VC, VN, ZA, ZM, ZW.

(22) International Filing Date:  
19 September 2008 (19.09.2008)

(25) Filing Language: English

(26) Publication Language: English

(30) Priority Data:  
0702125-6 25 September 2007 (25.09.2007) SE

(71) Applicant (for all designated States except US): **OPTOSKAND AB** [SE/SE]; Krokslättis Fabriker 30, S-431 37 Mölndal (SE).

(84) Designated States (unless otherwise indicated, for every kind of regional protection available): ARIPO (BW, GH, GM, KE, LS, MW, MZ, NA, SD, SL, SZ, TZ, UG, ZM, ZW), Eurasian (AM, AZ, BY, KG, KZ, MD, RU, TJ, TM), European (AT, BE, BG, CH, CY, CZ, DE, DK, EE, ES, FI, FR, GB, GR, HR, HU, IE, IS, IT, LT, LU, LV, MC, MT, NL, NO, PL, PT, RO, SE, SI, SK, TR), OAPI (BF, BJ, CF, CG, CI, CM, GA, GN, GQ, GW, ML, MR, NE, SN, TD, TG).

(72) Inventors; and

(75) Inventors/Applicants (for US only): **ROOS, Sven-Olov** [SE/SE]; Nyponvägen 42, S-448 37 Floda (SE). **BLOMSTER, Ola** [SE/SE]; Råvekärmsgatan 127, S-431 33 Mölndal (SE). **UHRWING, Thomas** [SE/SE]; Meijjerbergsgatan 8, S-412 60 Göteborg (SE).

Published:  
— with international search report

(54) Title: OPTICAL FIBER CONTACT

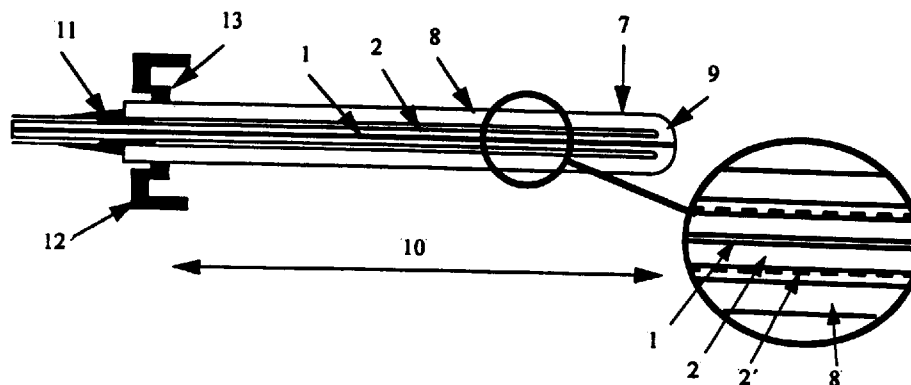

Fig 2

(57) Abstract: The present invention relates to an optical fiber contact for transmitting moderate-magnitude optical power, specifically power in the range of 50-500W. The fiber contact comprises an optical fiber having an inner core (1) and a surrounding cladding (2) for transmitting the radiation in the core. In order to mechanically stabilise the optical fiber it also comprises additional surrounding layers (3) in the form of so-called buffer and jackets. According to the invention the forward part (7) of the optical fiber contact is surrounded by a transparent tubular member (8), preferably made of a material similar to the material of the cladding (2), and which tubular member is extending a certain length (10) along the outer cylindrical surface of the cladding. This means that there is no heating by power loss radiation, as the power loss radiation is leaving the contact as optical radiation. In order to disperse any radiation propagating within the cladding (2), the cladding is provided with a roughening or additional layers of a transparent material. In case of additional layers of transparent material then the outermost layer should be roughened.



WO 2009/041874 A1

PN 16

## Optical fiber contact

5 The present invention relates to an optical fiber contact for transmitting moderate-magnitude optical power, specifically power in the range of 50-500W, comprising an optical fiber having an inner core and a surrounding cladding for transmitting the radiation within the core, as well as additional surrounding layers or protecting jackets in order to mechanically stabilise the optical fiber.

10

In order to avoid damage of the optical fiber contact in case of incident radiation outside the core of the fiber, or radiation reflected back to the fiber contacts, specific methods have been developed to take care of such power loss. When transmitting low optical power a more conventional type of fiber contact might be used, but in case of high optical power some kind of cooling is required, for instance means for absorbing incident power loss radiation at least partially in a flowing coolant.

15

Optical fiber cables for transmitting optical power in the range of some mW up to several kW are frequently used in industrial applications. For such applications specific type of contacts have been developed to transmit the radiation between different units. For low optical power it is previously known a contact type called SMA, based on a ferrule which is centering the fiber. The ferrule can be made of a metal, or a ceramic material in order to sustain more high optical power. Such a contact is small and has a low manufacturing cost, but has a limited use because of low cooling capacity so that the contact might be damaged under heavy heating.

20 For that reason there are other types of fiber contacts for high optical power on the market which are based on the fact that a certain length of the fiber is detached. However, only a limited increase of capacity can be achieved by this type of contact design. The contact might transmit high optical power, but if the radiation for some reason comes outside the core of the fiber the contact might be destroyed. For that reason this type of contact should be used only

25 for optical power up to some tenths of W.

30

The main reason for a damage in the optical system is the heating. Normally, an optical fiber has an inner core made of glass and one or more surrounding layers having a refractive index which exceeds the refractive index of the core in order to “lock” the radiation into the core

without any power loss. Such a surrounding layer or layers are called the cladding of the fiber. Outside the cladding there are also one or more protecting layers to stabilise the fiber mechanically. These layers are called buffers or jackets, and they are optimized for a high mechanical capacity but they do not have the necessary optical capacity to take care of high optical power. In case of radiation entering into the cladding such radiation is propagating through the cladding up to the area in which the surrounding protecting layers are connected to the cladding. This is a critical region of the fiber, and therefore a damage might be expected here.

Another critical region of the fiber, which is exposed to damages, is the part of the fiber which is in a mechanical contact with a supporting element. Radiation transmitted in the cladding might leak out in such contacting points and cause a damage of the fiber. As soon as the fiber is built into a contact, the fiber must be maintained and centered in a correct position in the contact body and therefore some mechanical component is required to hold the fiber and which then also comes into a mechanical contact with the fiber.

Different methods to take care of the unwanted power radiation and protect the fiber components against damages are already known. In fiber contacts for high optical power unwanted radiation can be removed from the cladding by means of so-called mode stripping, see for instance EP 0619508. In this case the cladding is provided with an additional layer which can be roughened for diverging unwanted radiation, which is entered into the cladding, into the surroundings. By making the fiber contact big enough, and thereby the outer surface exposed to the surroundings big enough, unwanted heating can be reduced, see for instance DE 4305313. There are also other types of cooling methods, specifically by means of inner water cooling in the contact so that unwanted power radiation is spread away, see EP 0910810.

In SE 0600263-8 it is described another example of an optical fiber contact for high optical power. In this case the end surface of the fiber is in optical contact with a body of a transparent material, for instance a rod or any other type of a solid body made of quartz, which body in connection with the optical fiber end has a surface area exceeding the contact surface area of the fiber end and has a conical design. By such a design of the surface of the transparent body a more efficient flowing geometry is provided around the fiber end. Furthermore, such a surface provides an increased area for incident power loss radiation as well as deflection of such incident radiation towards the optical axis of the fiber contact.

The cooling methods which have been described now can be used also for very high optical power. However, such optical fiber contacts are complicated, expensive and voluminous. There is a need for an optical fiber contact to be used for moderate-magnitude power radiation, typically 50-500 W, and which are not too complicated and voluminous.

According to the invention the forward part of the optical fiber contact is transparent so that power loss radiation is leaving the fiber contact in the form of optical radiation without any heating of the contact.

According to a preferred embodiment of the invention the forward part of the optical fiber contact is surrounded by a transparent tubular member, preferably made of a material similar to the cladding material. The tubular member is extending a certain length along the outer cylindrical surface of the cladding, surrounding and connected to the cladding along this length distance.

According to a further preferred embodiment the tubular member and the fiber are fused together at the front end to provide a single mechanical structure.

In the following the invention will be described more in detail with reference to the accompanying drawings, in which

Figure 1 illustrates what happens in a typical optical fiber contact when over-heated,

Figure 2 schematically illustrates an optical fiber contact according to the invention in which the forward part of the optical fiber contact is surrounded by a transparent tubular member,

Figure 3 illustrates an alternative embodiment with a non-transparent, but light-scattering member arranged in the rear region of the contact,

Figure 4 illustrates a first application example of the fiber contact,

Figure 5 illustrates a second application example of the fiber contact, and

Figure 6 illustrates a device for minimizing back-reflections.

In figure 1 it is illustrated the general design of a conventional optical fiber having areas which might be over-heated and damaged when the fiber is exposed to incident power loss radiation. The optical fiber comprises an inner core 1, for instance made of quartz glass, for transmitting radiation, and a surrounding cladding 2, for example made of glass or some polymer, and having a refractive index exceeding the refractive index of the core to optically "lock" the radiation into the core without any power loss. Outside the cladding there are one or more layers 3 of protecting jackets or buffers to mechanically stabilise the fiber. These layers are optimized for mechanical capacity and does not necessarily have the required optical capacity to take care of high optical power. As the fiber is built into a contact member the fiber also has to be fixed positioned by means of any mechanical component. These outer mechanical components have not been illustrated in figure 1.

In case of an incident radiation 4 into the cladding 2 the radiation is propagating through the cladding, indicated by the arrow 5 in the figure, to the region in which the surrounding layers 3 are connected to the cladding, indicated by numeral 6 in the figure. This is a critical area for the fiber, an area in which it is often an over-heating which might lead to a damage of the fiber. Other critical areas on the fiber are those areas in which the mechanical elements are supporting the fiber. In these areas radiation in the cladding might leak out and cause damages. The fiber has to be supported in these areas to be centered in the fiber contact.

In figure 2 it is illustrated an optical fiber contact which according to the invention is provided with a transparent forward part 7. This means that there is no heating by power loss radiation, as the power loss radiation is leaving the contact as optical radiation. The fiber with its core 1 and cladding 2 is inserted into a transparent tubular member 8 preferably made of a material similar to the cladding, i e made of glass or some polymer, having the same refractive index, or slightly higher than the cladding. The transparent tubular member 8 is surrounding the cladding along a certain distance 10, so that the inner cylindrical surface of the tubular member is adapted to the outer cylindrical surface of the cladding. In the front end the tubular member and the fiber are preferably fused together to form a mechanical structure 9.

On the cladding 2 it is also provided a mode stripper, schematically illustrated by the dotted line 2' in figure 2, either by means of a roughening of the cladding surface to a matt-finish or

by means of a further layer having a refractive index corresponding to the refractive index of the cladding, or slightly higher. If radiation for some reason goes into the cladding, such radiation is gradually leaving the cladding along a certain distance 10. The distance 10 should be long enough so that the remaining radiation in the cladding does not harm the surrounding layer or details. At least one of the cylindrical surfaces of the outer tubular member, preferably its outer cylindrical surface, could be roughened like the cladding or matt-finished, so that the radiation is reflected away from this sleeve prior to the termination of the contact. Even in this case the distance 10 should be selected long enough so that the radiation power is reduced to such a level that it does not harm components and glue joints at the rear part of the contact. This means that glue joints 11 and non-transparent mechanical components such as locking nuts 12 and rings 13 could be used in these rear regions, as the radiation power has been reduced to such an extent that it does not harm. The length of the transparent tube is typically 30-100 mm, while its outer diameter is typically 1-5 mm.

The end surface of the fiber is centered against the outer diameter of the transparent tubular member 8 in the forward part 7 of the fiber contact. If necessary grinding of the surface might be carried out for the centering.

In figure 3 it is illustrated another example of the fiber contact. According to the invention, also in this case the optical fiber with its core 1 and cladding 2 is inserted into a transparent tubular member 8, preferably made of a material similar to the cladding material, i.e. glass or some polymer. At the forward part the sleeve and the fiber are fused together to form a mechanical structure 9. A non-transparent, non-absorbing but light-scattering sleeve member 14 is provided at the rear part of the fiber contact as a further protection of the rear glue joint 11. This means that the length 10 can be reduced. The non-transparent, non-absorbing but light-scattering sleeve member 14 could be made of for instance aluminium oxide ceramics ( $\text{Al}_2\text{O}_3$ ) or the like, and it could have the same outer dimensions as the transparent tubular member 8 so that it also is surrounding the cladding and is forming an extension of the transparent tube. Also in this case non-transparent mechanical components such as locking nuts 12 and rings 13 could be applied in the rear regions of the contact.

In figures 4 and 5 it is illustrated some proposed applications of the fiber contact. In the application of figure 4 the forward part of the fiber contact is held by means of a supporting element 15 having a conical aperture 16. If necessary this supporting element 15 can be made

of a non-absorbing material. The mechanical design of the forward and rear parts of the fiber contact provides for a cavity 17 formed between the outer transparent tubular member 8 of the fiber contact, a cylindrical housing 18, the front supporting element 15 and rear supporting rings 12, 13. By means of this cavity 17 the power loss is distributed over an increased surface, which means that the risk for over-heating and damages is minimized.

In figure 5 it is illustrated another application in which the fiber contact is arranged in a substantially cylindrical guiding member 19 in a surrounding body 20 made of a heat-conducting material. If necessary this body might be provided with channels 21 for water cooling.

If the fiber contact is used together with equipments susceptible to optical back reflections the front end 22 of the fiber contact might be inclined by grinding and polished, see figure 6. In case of back-reflections, the radiation is deviated by means of the inclined and polished end surface of the fiber contact.

The invention is not limited to the examples that have been illustrated here but can be varied within the scope of the following claims.

20

25

30

## CLAIMS

1. Optical fiber contact for transmitting moderate-magnitude optical power, specifically power in the range of 50-500W, comprising an optical fiber having an inner core (1) and a surrounding cladding (2) for transmitting the radiation within the core, as well as additional surrounding layers (3) in order to mechanically stabilise the optical fiber, characterized in that the forward part (7) of the optical fiber contact is surrounded by a transparent tubular member (8), preferably made of a material similar to the material of the cladding (2), and which tubular member is extending a certain length (10) along the outer cylindrical surface of the cladding, and that a mode stripper (2') is applied to the cladding (2) in order to disperse any radiation propagating within the cladding (2).
2. Optical fiber contact according to claim 1, characterized in that the mode stripper (2') comprises a roughening of the cladding (2).
3. Optical fiber contact according to claim 1, characterized in that the mode stripper (2') comprises an additional layer of a transparent material having a roughening and applied to the cladding (2).
4. Optical fiber contact according to claim 1, characterized in that the transparent tubular member (8) is surrounding the cladding (2) along said length (10).
5. Optical fiber contact according to claim 1, characterized in that the transparent tubular member (8) and the fiber are fused together at the front end of the forward part (7) of the contact forming a mechanical structure (9).
6. Optical fiber contact according to claim 1, characterized in that the transparent tubular member (8) has an outer diameter of 1-5 mm and a length of 30-100 mm.
7. Optical fiber contact according to claim 1, characterized in that at least one of the cylindrical surfaces of the tubular member is roughened.
8. Optical fiber contact according to claim 1, characterized in that a non-transparent, non-absorbing but light-scattering sleeve member (14) is applied to the rear

region of the contact, surrounding the cladding and forming an extension of said transparent tubular member (8).

9.           Optical fiber contact according to claim 8, characterized in that said  
5 non-transparent, non-absorbing but light-scattering sleeve member (14) is made of aluminium oxide ceramics ( $\text{Al}_2\text{O}_3$ ) or the like and having substantially the same outer diameter as the transparent tubular member (8).

10.           Optical fiber contact according to claim 1, characterized in that the  
10 forward part (7) of the fiber contact is held by a front supporting element (15) having a conical aperture (16) and that the forward (7) and rear parts of the fiber contact provides for a cavity (17) formed between the outer transparent tubular member (8) of the fiber contact, a cylindrical housing (18), the front supporting element (15) and a rear ring-shaped supporting  
15 element (12, 13).

11.           Optical fiber contact according to claim 10, characterized in that the  
front supporting element (15) is made of a non-absorbing material.

12.           Optical fiber contact according to claim 5, characterized in that the  
20 front end (22) of the fiber contact has an inclined grinded and polished surface to deviate back-reflected radiation.

25

30

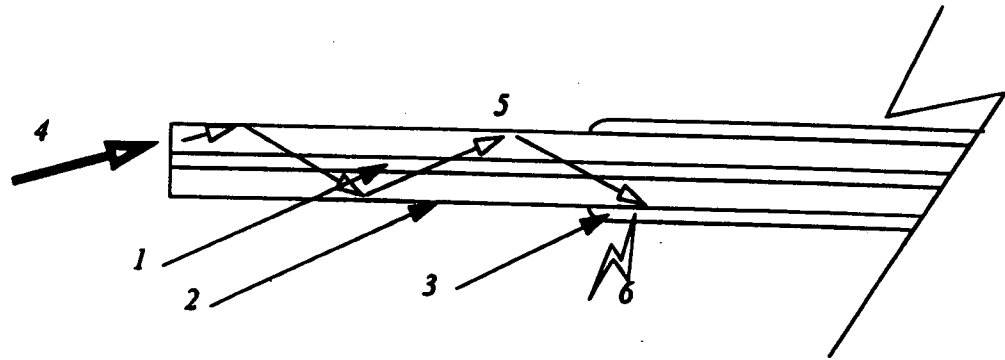

Fig. 1

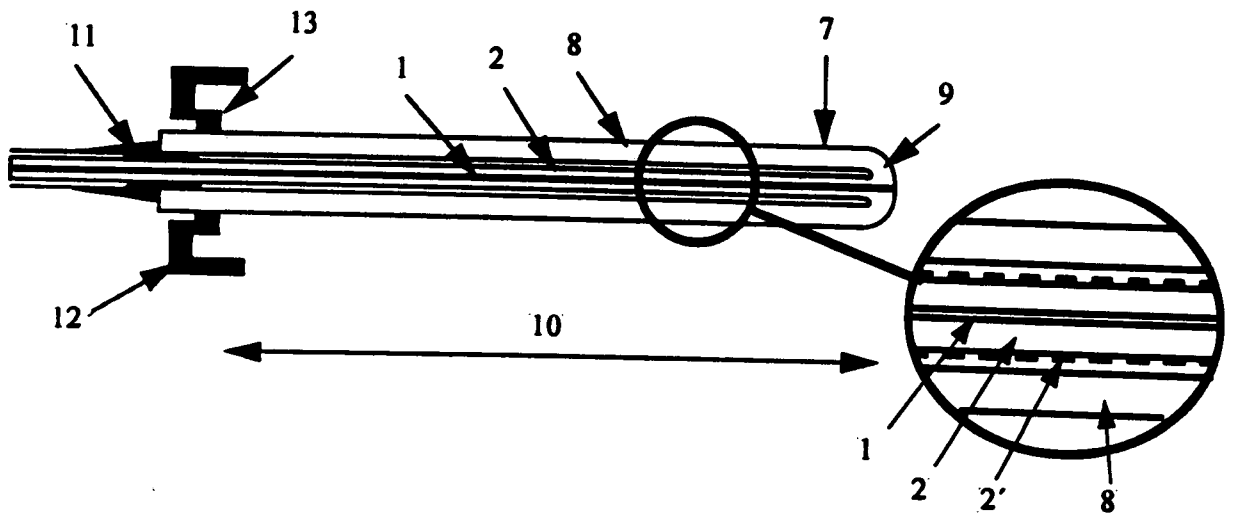

Fig. 2

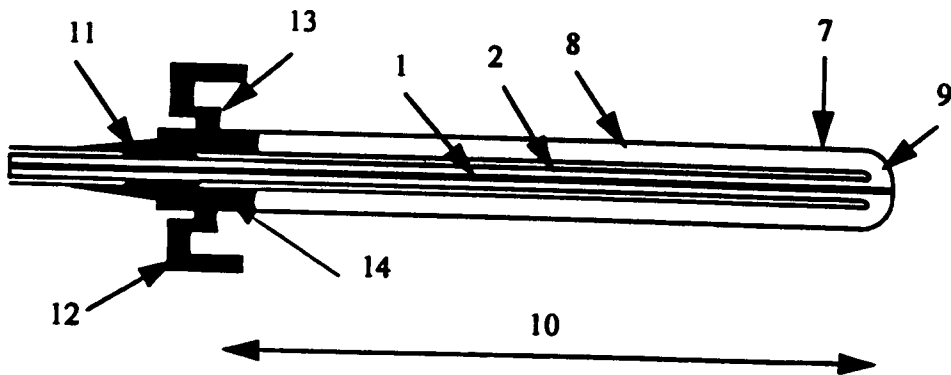

Fig. 3

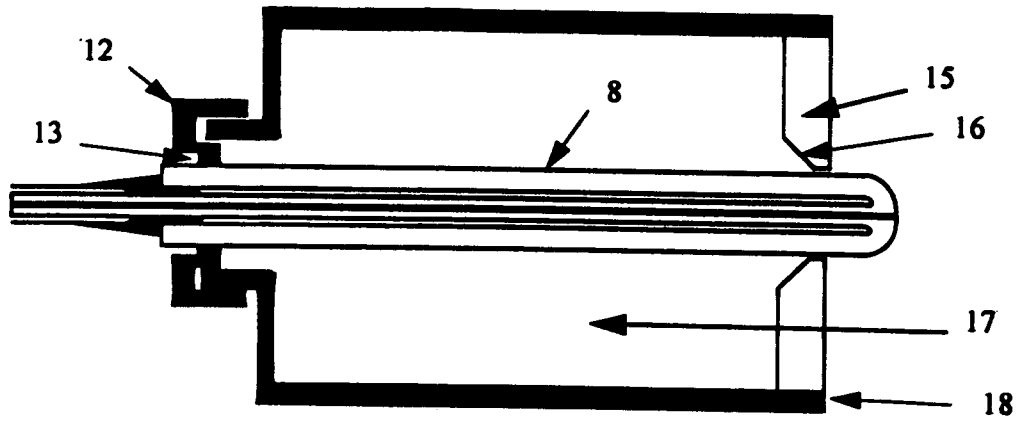

Fig 4

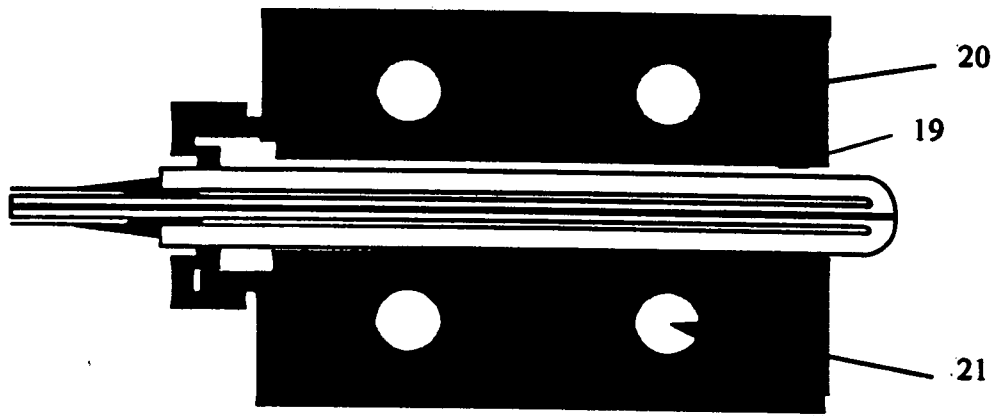

Fig 5

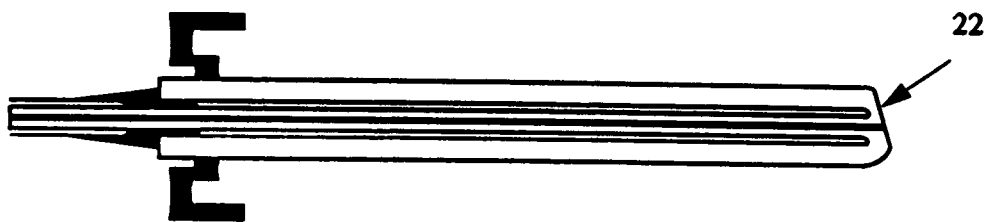

Fig 6

## INTERNATIONAL SEARCH REPORT

International application No.  
PCT/SE2008/000526

## A. CLASSIFICATION OF SUBJECT MATTER

**IPC: see extra sheet**

According to International Patent Classification (IPC) or to both national classification and IPC

## B. FIELDS SEARCHED

Minimum documentation searched (classification system followed by classification symbols)

**IPC: G02B**

Documentation searched other than minimum documentation to the extent that such documents are included in the fields searched

**SE,DK,FI,NO classes as above**

Electronic data base consulted during the international search (name of data base and, where practicable, search terms used)

**EPO-INTERNAL, WPI DATA, PAJ**

## C. DOCUMENTS CONSIDERED TO BE RELEVANT

Category*	Citation of document, with indication, where appropriate, of the relevant passages	Relevant to claim No.
X	US 20070172174 A1 (SCERBAK, D G ET AL), 26 July 2007 (26.07.2007), paragraphs [0015]; [0022]; [0036]-[0039]; [0042], figures 1-3,6 --	1-12
A	WO 9801784 A1 (PERMANOVA LASERSYSTEM AB), 15 January 1998 (15.01.1998), figure 5b, abstract -- -----	10,11

Further documents are listed in the continuation of Box C.  See patent family annex.

\* Special categories of cited documents:

"A" document defining the general state of the art which is not considered to be of particular relevance  
 "E" earlier application or patent but published on or after the international filing date  
 "L" document which may throw doubts on priority claim(s) or which is cited to establish the publication date of another citation or other special reason (as specified)  
 "O" document referring to an oral disclosure, use, exhibition or other means  
 "P" document published prior to the international filing date but later than the priority date claimed

"T" later document published after the international filing date or priority date and not in conflict with the application but cited to understand the principle or theory underlying the invention  
 "X" document of particular relevance: the claimed invention cannot be considered novel or cannot be considered to involve an inventive step when the document is taken alone  
 "Y" document of particular relevance: the claimed invention cannot be considered to involve an inventive step when the document is combined with one or more other such documents, such combination being obvious to a person skilled in the art  
 "&" document member of the same patent family

Date of the actual completion of the international search

7 January 2009

Date of mailing of the international search report

12-01-2009

Name and mailing address of the ISA/  
Swedish Patent Office  
Box 5055, S-102 42 STOCKHOLM  
Facsimile No. +46 8 666 02 86

Authorized officer

Magnus Westöö /LR  
Telephone No. +46 8 782 25 00

**International patent classification (IPC)****G02B 6/42** (2006.01)**G02B 6/38** (2006.01)**Download your patent documents at [www.prv.se](http://www.prv.se)**

The cited patent documents can be downloaded at [www.prv.se](http://www.prv.se) by following the links:

- In English/Searches and advisory services/Cited documents (service in English) or
- e-tjänster/anförda dokument (service in Swedish).

Use the application number as username.

The password is **HKUDXYMEUA**.

Paper copies can be ordered at a cost of 50 SEK per copy from PRV InterPat (telephone number 08-782 28 85).

Cited literature, if any, will be enclosed in paper form.

INTERNATIONAL SEARCH REPORT  
Information on patent family members

01/11/2008

International application No.

PCT/SE2008/000526

US	20070172174	A1	26/07/2007	US	7306376	B	11/12/2007
-----							
WO	9801784	A1	15/01/1998	AT	290228	T	15/03/2005
				CZ	291894	B	18/06/2003
				CZ	9804313	A	16/06/1999
				DE	69732632	D,T	29/12/2005
				EP	0910810	A,B	28/04/1999
				ES	2239358	T	16/09/2005
				HU	224381	B	29/08/2005
				HU	9902835	A	28/12/1999
				JP	3699486	B	28/09/2005
				JP	2000514930	T	07/11/2000
				KR	2000022476	A	25/04/2000
				KR	20000022476	A	25/04/2000
				RU	2180130	C	27/02/2002
				SE	509706	C	01/03/1999
				SE	9602666	A,L	06/01/1998
				US	6167177	A	26/12/2000
-----							