

(No Model.)

J. B. ATON.

LEVER ATTACHMENT FOR RAISING OR LOWERING BUGGY TOPS.

No. 526,430.

Patented Sept. 25, 1894.

Fig. 1.

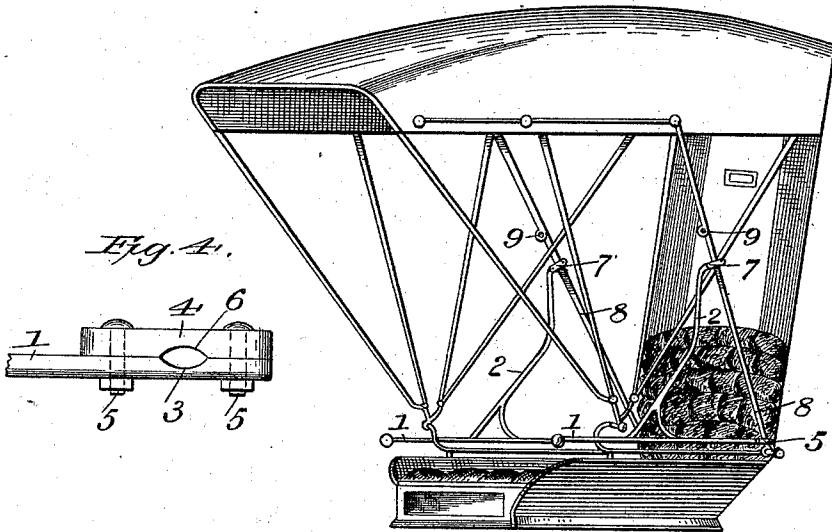

Fig. 4.

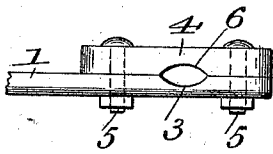

Fig. 2.

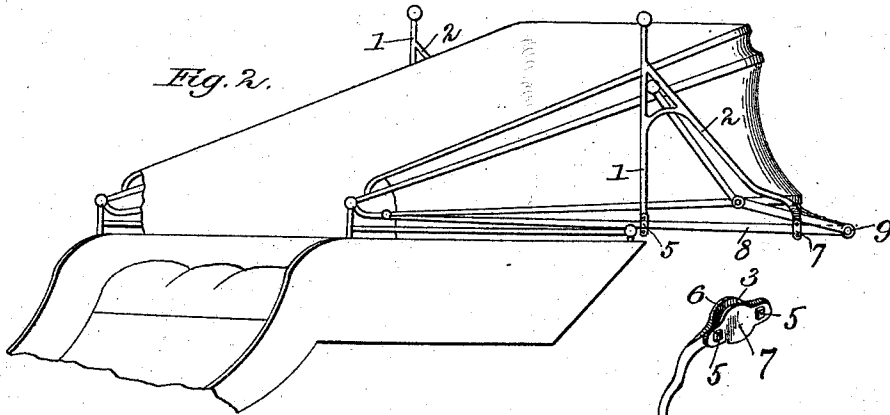

Fig. 3.

WITNESSES
F. L. Curand.
Jose Gregory

INVENTOR
James B. Aton.
by J. Fred Rely
his Attorney

UNITED STATES PATENT OFFICE.

JAMES B. ATON, OF MORGANFIELD, KENTUCKY.

LEVER ATTACHMENT FOR RAISING OR LOWERING BUGGY-TOPS.

SPECIFICATION forming part of Letters Patent No. 526,430, dated September 25, 1894.

Application filed March 17, 1894. Serial No. 604,010. (No model.)

To all whom it may concern:

Be it known that I, JAMES B. ATON, a citizen of the United States, residing at Morganfield, in the county of Union and State of Kentucky, have invented certain new and useful Improvements in Attachments for Raising or Lowering Buggy-Tops; and I do declare the following to be a full, clear, and exact description of the invention, such as will enable others skilled in the art to which it appertains to make and use the same, reference being had to the accompanying drawings, and to the figures of reference marked thereon, which form a part of this specification.

My invention consists in an attachment for raising and lowering buggy and carriage tops, and has for its object to provide a simple, convenient, and inexpensive device which can be readily attached to any buggy or carriage, and by means of which the occupant of the buggy or carriage can readily and easily raise and lower its top while sitting on a normal position on the seat; thus doing away with all necessity for either having to alight or be obliged to manipulate the braces at a great inconvenience by reaching out of the carriage or buggy and causing the braces to "break joint" first on one side and then upon the other in lowering, and in locking the joints when raised. My invention entirely overcomes these objections, and is designed to be manufactured and sold separately, and can be readily attached in operative position by any person; and the invention will be hereinafter fully described and claimed.

Referring to the accompanying drawings, Figure 1 is a perspective view, showing my invention secured in operative position. Fig. 2 is a perspective view showing the top folded back. Fig. 3 shows the attachment alone. Fig. 4 is a detailed view of one of its clamping ends.

Referring to the several parts by their designating numerals, the same numerals indicating corresponding parts in the several figures: 1 indicates the straight lower handle rod of the attachment, the outer end of this rod or bar being turned into a knob and forming the handle by means of which the attachment is operated. The rear end of this

bar has a curved seat or recess, 3, formed in its inner face; and against the inner side of this end is secured the small clamping plate 4, by means of screws 5 passing through its ends and the bar 1. The inner side of this clamping plate is formed with a curved seat or recess, 6, registering with the seat 3 of the bar. This rear end of the bar 1 is clamped on the hinge iron 8 of the buggy top, just above the lower pivotal point of the latter, at the back corner of the seat, as shown, the hinge iron fitting in the recesses 3 and 6 of the bar and clamping plate. The curved rod or arm 2 of the attachment extends up from a point near its front handle end, and curves back until its rear end, 7, which is provided with a clamping device like that at the rear end of the bar 1, can be conveniently clamped to the upper part of the hinge iron immediately below the joint 9 of the same, as shown in Fig. 1. One of these attachments is secured on each side of the buggy top, as shown.

It will now be seen that when the buggy top is up, as shown in Fig. 1, that the handle bars 1 extend horizontally, in convenient reach of the occupant while sitting in a normal position on the seat; and that when the occupant desires to lower the top he can take hold of the outer ends of bars 1 and raise them, when the upper bars 2, pressing against the hinge irons just below their joints, will at once "break" said joints and the attachments will then swing the top back into its lowered position; and the top is as readily raised by taking hold of the elevated handles of bars 1 and pressing them forward and down into their horizontal positions, in which movement the attachments will raise the buggy top and lock the joints of the hinge irons in the position shown in Fig. 1, as will be readily understood. It is obvious that any other suitable clamping device may be used at the rear ends of the bars which will secure them to the hinge irons.

From the foregoing description, taken in connection with the accompanying drawings, the construction, operation, and advantages of my invention will be readily understood.

The attachment is very simple and inexpensive; it will be made in two or more sizes

to suit different sizes, and styles, of tops; and is designed to be sold separately and can be readily attached by the purchaser in a few minutes to his buggy. Its uses and advantages are above fully set forth.

5 Having thus described my invention, what I claim, and desire to secure by Letters Patent, is—

10 1. The herein described means for raising and lowering vehicle tops, consisting of a handle bar having a clamping device at its rear end to be fixed to the hinge iron of the top near the joint, an arm springing from the handle bar near its free end and bracingly
15 connected therewith and inclining rearwardly and outwardly therefrom and terminating in a clamping device opposite the clamping device of the handle bar to be attached to the

hinge iron of the top near its joint, substantially as described. 20

2. In a buggy top, the combination of a handle bar attached at its rear end to the hinge iron near its lower joint and extending approximately parallel with and contiguous to the top edge of the side bar of the seat
25 when the top is raised, and an arm bracingly connected with the handle bar near its outer end and inclining therefrom and attached to the said hinge bar near the middle joint, substantially as described. 30

In testimony whereof I affix my signature in presence of two witnesses.

JAMES B. ATON.

Witnesses:

T. P. ATON,
W. F. ATON.