



- (51) International Patent Classification:
H04L 29/02 (2006.01) H04W 74/00 (2009.01)
- (21) International Application Number:
PCT/CN2018/097029
- (22) International Filing Date:
25 July 2018 (25.07.2018)
- (25) Filing Language: English
- (26) Publication Language: English
- (30) Priority Data:
PCT/CN2017/095169
31 July 2017 (31.07.2017) CN

(74) Agent: NTD PATENT & TRADEMARK AGENCY LIMITED; 10th Floor, Tower C, Beijing Global Trade Center, 36 North Third Ring Road East, Dongcheng District, Beijing 100013 (CN).

(81) Designated States (unless otherwise indicated, for every kind of national protection available): AE, AG, AL, AM, AO, AT, AU, AZ, BA, BB, BG, BH, BN, BR, BW, BY, BZ, CA, CH, CL, CN, CO, CR, CU, CZ, DE, DJ, DK, DM, DO, DZ, EC, EE, EG, ES, FI, GB, GD, GE, GH, GM, GT, HN, HR, HU, ID, IL, IN, IR, IS, JO, JP, KE, KG, KH, KN, KP, KR, KW, KZ, LA, LC, LK, LR, LS, LU, LY, MA, MD, ME, MG, MK, MN, MW, MX, MY, MZ, NA, NG, NI, NO, NZ, OM, PA, PE, PG, PH, PL, PT, QA, RO, RS, RU, RW, SA, SC, SD, SE, SG, SK, SL, SM, ST, SV, SY, TH, TJ, TM, TN, TR, TT, TZ, UA, UG, US, UZ, VC, VN, ZA, ZM, ZW.

(71) Applicant: QUALCOMM INCORPORATED [US/US]; ATTN: International IP Administration, 5775 Morehouse Drive, San Diego, California 92121-1714 (US).

(72) Inventors; and

(71) Applicants (for US only): WEI, Chao [CN/CN]; 5775 Morehouse Drive, San Diego, California 92121-1714 (US). BHATTAD, Kapil [IN/IN]; 5775 Morehouse Drive, San Diego, California 92121-1714 (US). XU, Hao [US/CN]; 5775 Morehouse Drive, San Diego, California 92121-1714 (US). RICO ALVARINO, Alberto [ES/US]; 5775 Morehouse Drive, San Diego, California 92121-1714 (US).

(84) Designated States (unless otherwise indicated, for every kind of regional protection available): ARIPO (BW, GH, GM, KE, LR, LS, MW, MZ, NA, RW, SD, SL, ST, SZ, TZ, UG, ZM, ZW), Eurasian (AM, AZ, BY, KG, KZ, RU, TJ, TM), European (AL, AT, BE, BG, CH, CY, CZ, DE, DK, EE, ES, FI, FR, GB, GR, HR, HU, IE, IS, IT, LT, LU, LV, MC, MK, MT, NL, NO, PL, PT, RO, RS, SE, SI, SK, SM, TR), OAPI (BF, BJ, CF, CG, CI, CM, GA, GN, GQ, GW, KM, ML, MR, NE, SN, TD, TG).

(54) Title: UPLINK AND DOWNLINK GRANTS FOR NARROWBAND OPERATIONS

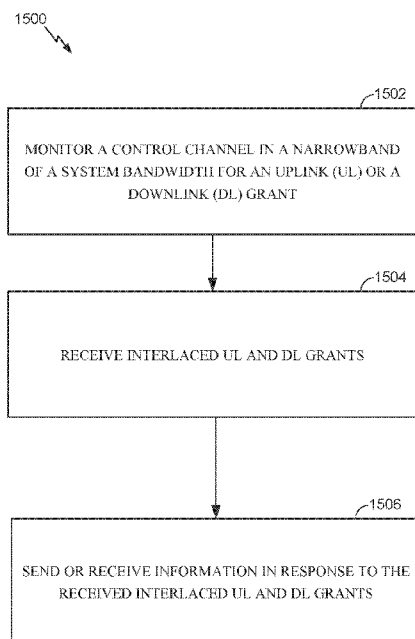

FIG. 15

(57) Abstract: Aspects of the present disclosure provide techniques and apparatus for wireless communication. In one aspect, a method is provided which may be performed by a wireless device such as a user equipment (UE), which can be an Internet-of-things (IoT) device. The method generally includes monitoring a control channel in a narrowband of a system bandwidth for an uplink (UL) or a downlink (DL) grant, receiving interlaced UL and DL grants, sending or receiving information in response to the received interlaced UL and DL grants.



Published:

— *with international search report (Art. 21(3))*

UPLINK AND DOWNLINK GRANTS FOR NARROWBAND OPERATIONS

CROSS REFERENCE

[0001] The present Application for Patent claims priority to International Patent Application Number PCT/CN2017/095169, filed July 31, 2017, assigned to the assignee hereof.

BACKGROUND

Field of the Disclosure

[0002] Certain aspects of the present disclosure generally relate to wireless communications and, more particularly, to uplink (UL) and downlink (DL) grants for narrowband operations.

Description of Related Art

[0003] Wireless communication systems are widely deployed to provide various types of communication content such as voice, data, and so on. These systems may be multiple-access systems capable of supporting communication with multiple users by sharing the available system resources (e.g., bandwidth and transmit power). Examples of such multiple-access systems include code division multiple access (CDMA) systems, time division multiple access (TDMA) systems, frequency division multiple access (FDMA) systems, 3rd Generation Partnership Project (3GPP) Long Term Evolution (LTE)/LTE-Advanced (LTE-A) systems and orthogonal frequency division multiple access (OFDMA) systems.

[0004] Generally, a wireless multiple-access communication system can simultaneously support communication for multiple wireless terminals. Each terminal communicates with one or more base stations (BSs) via transmissions on the forward and reverse links. The forward link (or downlink) refers to the communication link from the BSs to the terminals, and the reverse link (or uplink) refers to the communication link from the terminals to the BSs. This communication link may be established via a single-input single-output, multiple-input single-output or a multiple-input multiple-output

(MIMO) system.

[0005] A wireless communication network may include a number of BSs that can support communication for a number of wireless devices. Wireless devices may include user equipments (UEs). Machine type communications (MTC) may refer to communication involving at least one remote device on at least one end of the communication and may include forms of data communication which involve one or more entities that do not necessarily need human interaction. MTC UEs may include UEs that are capable of MTC communications with MTC servers and/or other MTC devices through Public Land Mobile Networks (PLMN), for example. Wireless devices may include Internet-of-Things (IoT) devices (e.g., narrowband IoT (NB-IoT) devices). IoT may refer to a network of physical objects, devices, or “things”. IoT devices may be embedded with, for example, electronics, software, or sensors and may have network connectivity, which enable these devices to collect and exchange data.

[0006] Some next generation, NR, or 5G networks may include a number of base stations, each simultaneously supporting communication for multiple communication devices, such as UEs. In LTE or LTE-A network, a set of one or more BSs may define an e NodeB (eNB). In other examples (e.g., in a next generation or 5G network), a wireless multiple access communication system may include a number of distributed units (e.g., edge units (EUs), edge nodes (ENs), radio heads (RHs), smart radio heads (SRHs), transmission reception points (TRPs), etc.) in communication with a number of central units (e.g., CU, central nodes (CNs), access node controllers (ANCs), etc.), where a set of one or more distributed units (DUs), in communication with a CU, may define an access node (e.g., AN, a new radio base station (NR BS), a NR NB, a network node, a gNB, a 5G BS, an access point (AP), etc.). A BS or DU may communicate with a set of UEs on downlink channels (e.g., for transmissions from a BS or to a UE) and uplink channels (e.g., for transmissions from a UE to a BS or DU).

[0007] These multiple access technologies have been adopted in various telecommunication standards to provide a common protocol that enables different wireless devices to communicate on a municipal, national, regional, and even global level. NR (e.g., 5G radio access) is an example of an emerging telecommunication standard. NR is a set of enhancements to the LTE mobile standard promulgated by 3GPP. NR is designed to better support mobile broadband Internet access by improving spectral

efficiency, lowering costs, improving services, making use of new spectrum, and better integrating with other open standards using OFDMA with a cyclic prefix (CP) on the downlink (DL) and on the uplink (UL) as well as support beamforming, MIMO antenna technology, and carrier aggregation.

[0008] However, as the demand for mobile broadband access continues to increase, there exists a need for further improvements in LTE, MTC, IoT, and NR (new radio) technology. Preferably, these improvements should be applicable to other multi-access technologies and the telecommunication standards that employ these technologies.

SUMMARY

[0009] The systems, methods, and devices of the disclosure each have several aspects, no single one of which is solely responsible for its desirable attributes. Without limiting the scope of this disclosure as expressed by the claims which follow, some features will now be discussed briefly. After considering this discussion, and particularly after reading the section entitled "DETAILED DESCRIPTION" one will understand how the features of this disclosure provide advantages that include improved communications between access points and stations in a wireless network.

[0010] Certain aspects of the present disclosure generally relate to uplink and downlink operations for narrowband operations.

[0011] Certain aspects of the present disclosure provide a method, performed by a wireless device, such as a user equipment (UE). The method generally includes monitoring a control channel in a narrowband of a system bandwidth for an uplink (UL) or a downlink (DL) grant, receiving interlaced UL and DL grants, and sending or receiving information in response to the received interlaced UL and DL grants.

[0012] Certain aspects of the present disclosure provide a method, performed by a wireless device, such as a UE. The method generally includes monitoring a control channel in a narrowband of a system bandwidth for an uplink (UL) or a downlink (DL) grant, receiving two consecutive UL or DL grants, wherein the consecutive UL or DL grants have a same HARQ process identification (ID), and selecting one of the grants to use based, at least in part, on at least one of: the grant meeting an energy metric threshold, the grant being received first, or the grant being received second, or selecting both grants

to use, wherein the grants are treated as hybrid automatic repeat request (HARQ) retransmissions.

[0013] Certain aspects of the present disclosure provide a method, performed by a wireless device, such as a UE. The method generally includes monitoring a control channel in a narrowband of a system bandwidth for an uplink (UL) or a downlink (DL) grant, receiving two consecutive UL or DL grants, sending or receiving information in response to the received two consecutive UL and DL grants, and in response to the sending or receiving information, identifying a collision, the collision comprising at least one of: collision between first DL data channel and second DL data channel, collision between the second DL data channel and first HARQ acknowledgement (HARQ-ACK) signaling for the first DL data channel, collision between first HARQ-ACK signaling for the first DL data channel and second HARQ-ACK signaling for the second DL data channel, or collision between first UL data channel and second UL data channel.

[0014] Certain aspects of the present disclosure provide a method, performed by a wireless device, such as a base station (BS). The method generally includes transmitting interlaced uplink (UL) and downlink (DL) grants on a control channel in a narrowband of a system bandwidth, and sending or receiving information in response to the transmitted interlaced UL and DL grants.

[0015] Certain aspects of the present disclosure provide a method, performed by a wireless device, such as a base station (BS). The method generally includes transmitting, to a user equipment (UE), two consecutive uplink (UL) or downlink (DL) grants on a control channel in a narrowband of a system bandwidth, the consecutive UL or DL grants having a same HARQ process identification (ID), wherein: a grant for use is selected by the UE based, at least in part, on at least one of: the grant meeting energy metric threshold, the grant being received first, or the grant being received second, or both grants are selected for use by the UE, wherein the grants are treated as hybrid automatic repeat request (HARQ) retransmissions.

[0016] Certain aspects of the present disclosure provide a method, performed by a wireless device, such as a base station (BS). The method generally includes transmitting, to a user equipment (UE), two consecutive UL or DL grants on a control channel in a narrowband of a system bandwidth, sending or receiving information in response to the

transmitted two consecutive UL and DL grants, wherein, in response to the sending or receiving information, identifying a collision comprising at least one of: collision between first DL data channel and second DL data channel, collision between the second DL data channel and first HARQ acknowledgement (HARQ-ACK) signaling for the first DL data channel, collision between first HARQ-ACK signaling for the first DL data channel and second HARQ-ACK signaling for the second DL data channel; or collision between first UL data channel and second UL data channel.

[0017] Numerous other aspects are provided including methods, apparatus, systems, computer program products, computer-readable medium, and processing systems. To the accomplishment of the foregoing and related ends, the one or more aspects comprise the features hereinafter fully described and particularly pointed out in the claims. The following description and the annexed drawings set forth in detail certain illustrative features of the one or more aspects. These features are indicative, however, of but a few of the various ways in which the principles of various aspects may be employed, and this description is intended to include all such aspects and their equivalents.

BRIEF DESCRIPTION OF THE DRAWINGS

[0018] So that the manner in which the above-recited features of the present disclosure can be understood in detail, a more particular description, briefly summarized above, may be had by reference to aspects, some of which are illustrated in the appended drawings. It is to be noted, however, that the appended drawings illustrate only certain typical aspects of this disclosure and are therefore not to be considered limiting of its scope, for the description may admit to other equally effective aspects.

[0019] FIG. 1 is a block diagram conceptually illustrating an example of a wireless communication network, in accordance with certain aspects of the present disclosure.

[0020] FIG. 2 shows a block diagram conceptually illustrating an example of a base station (BS) in communication with a user equipment (UE) in a wireless communications network, in accordance with certain aspects of the present disclosure.

[0021] FIG. 3 is a block diagram conceptually illustrating an example of a frame structure in a wireless communications network, in accordance with certain aspects of the present disclosure.

[0022] FIG. 4 is a block diagram conceptually illustrating two exemplary subframe formats with the normal cyclic prefix, in accordance with certain aspects of the present disclosure.

[0023] FIG. 5 illustrates an exemplary subframe configuration for enhanced/evolved machine type communications (eMTC), in accordance with certain aspects of the present disclosure.

[0024] FIG. 6 illustrates an example deployment of narrowband Internet-of-Things (NB-IoT), in accordance with certain aspects of the present disclosure.

[0025] FIG. 7 illustrates an example logical architecture of a distributed radio access network (RAN), in accordance with certain aspects of the present disclosure.

[0026] FIG. 8 illustrates an example physical architecture of a distributed RAN, in accordance with certain aspects of the present disclosure.

[0027] FIG. 9 is a diagram illustrating an example of a downlink (DL)-centric subframe, in accordance with certain aspects of the present disclosure.

[0028] FIG. 10 is a diagram illustrating an example of an uplink (UL)-centric subframe, in accordance with certain aspects of the present disclosure.

[0029] FIG. 11 illustrates an example of Release 13 HARQ process timing and an example of Release 14 HARQ process timing, in accordance with certain aspects of the present disclosure.

[0030] FIG. 12 illustrates example interlaced grants (DL followed by UL) in accordance with certain aspects of the present disclosure.

[0031] FIG. 13 illustrates example interlaced grants (UL followed by DL) in accordance with certain aspects of the present disclosure.

[0032] FIG. 14 illustrates example interlaced NPDCCH and NPUSCH in accordance with certain aspects of the present disclosure.

[0033] FIG. 15 is a flow diagram illustrating example operations for receiving interlaced uplink and downlink grants in a narrowband of a system bandwidth, in

accordance with certain aspects of the present disclosure.

[0034] FIG. 16 is a flow diagram illustrating example operations for UE behavior when receiving back to back UL grants or DL grants with same HARQ IDs, in accordance with certain aspects of the present disclosure.

[0035] FIG. 17 is a flow diagram illustrating example operations for UE behavior in connection with collisions when receiving back to back UL grants or DL grants, in accordance with certain aspects of the present disclosure.

[0036] To facilitate understanding, identical reference numerals have been used, where possible, to designate identical elements that are common to the figures. It is contemplated that elements disclosed in one aspect may be beneficially utilized on other aspects without specific recitation.

DETAILED DESCRIPTION

[0037] Aspects of the present disclosure provide techniques for uplink and downlink operations for narrowband operations. The techniques described herein may be used for various wireless communication networks such as CDMA, TDMA, FDMA, OFDMA, SC-FDMA and other networks. The terms “network” and “system” are often used interchangeably. A CDMA network may implement a radio technology such as universal terrestrial radio access (UTRA), cdma2000, etc. UTRA includes wideband CDMA (WCDMA), time division synchronous CDMA (TD-SCDMA), and other variants of CDMA. cdma2000 covers IS-2000, IS-95 and IS-856 standards. A TDMA network may implement a radio technology such as global system for mobile communications (GSM). An OFDMA network may implement a radio technology such as evolved UTRA (E-UTRA), ultra mobile broadband (UMB), IEEE 802.11 (Wi-Fi), IEEE 802.16 (WiMAX), IEEE 802.20, Flash-OFDM®, etc. UTRA and E-UTRA are part of universal mobile telecommunication system (UMTS). 3GPP Long Term Evolution (LTE) and LTE-Advanced (LTE-A), in both frequency division duplex (FDD) and time division duplex (TDD), are new releases of UMTS that use E-UTRA, which employs OFDMA on the downlink and SC-FDMA on the uplink. UTRA, E-UTRA, UMTS, LTE, LTE-A and GSM are described in documents from an organization named “3rd Generation Partnership Project” (3GPP). cdma2000 and UMB are described in documents from an

organization named “3rd Generation Partnership Project 2” (3GPP2). NR (e.g., 5G radio access) is an example of an emerging telecommunication standard. NR is a set of enhancements to the LTE mobile standard promulgated by 3GPP. The techniques described herein may be used for the wireless networks and radio technologies mentioned above as well as other wireless networks and radio technologies. For clarity, certain aspects of the techniques are described below for LTE/LTE-Advanced, and LTE/LTE-Advanced (LTE-A) terminology is used in much of the description below. LTE and LTE-A are referred to generally as LTE.

[0038] It is noted that while aspects may be described herein using terminology commonly associated with 3G and/or 4G wireless technologies, aspects of the present disclosure can be applied in other generation-based communication systems, such as 5G and later.

EXAMPLE WIRELESS COMMUNICATIONS NETWORK

[0039] FIG. 1 illustrates an example wireless communication network 100, in which aspects of the present disclosure may be practiced. For example, techniques presented herein may be used for UL and DL grants for narrowband operation in wireless communication network 100, which may be narrowband Internet-of-things (NB-IoT) and/or an enhanced/evolved machine type communications (eMTC) network. Wireless communication network 100 may include base stations (BSs) 110 and user equipment (UEs) 120. In aspects, a BS 110 can determine at least one narrowband region of a wideband region for communication with a UE 120. UE 120, which may be a low cost device, such a NB-IoT device or an eMTC UE, can determine the narrowband region and receive, send, monitor, or decode information on the narrowband region for communication with BS 110.

[0040] Wireless communication network 100 may be a long term evolution (LTE) network or some other wireless network, such as a new radio (NR) or 5G network. Wireless communication network 100 may include a number of BSs 110 and other network entities. A BS is an entity that communicates with UEs and may also be referred to as a NR BS, a Node B (NB), an evolved/enhanced NB (eNB), a 5G NB, a gNB, an access point (AP), a transmission reception point (TRP), etc. Each BS may provide communication coverage for a particular geographic area. In 3GPP, the term “cell” can

refer to a coverage area of a BS and/or a BS subsystem serving this coverage area, depending on the context in which the term is used.

[0041] A BS may provide communication coverage for a macro cell, a pico cell, a femto cell, and/or other types of cell. A macro cell may cover a relatively large geographic area (e.g., several kilometers in radius) and may allow unrestricted access by UEs with service subscription. A pico cell may cover a relatively small geographic area and may allow unrestricted access by UEs with service subscription. A femto cell may cover a relatively small geographic area (e.g., a home) and may allow restricted access by UEs having association with the femto cell (e.g., UEs in a closed subscriber group (CSG)). A BS for a macro cell may be referred to as a macro BS. A BS for a pico cell may be referred to as a pico BS. A BS for a femto cell may be referred to as a femto BS or a home BS. In the example shown in FIG. 1, BS 110a may be a macro BS for a macro cell 102a, BS 110b may be a pico BS for a pico cell 102b, and BS 110c may be a femto BS for a femto cell 102c. A BS may support one or multiple (e.g., three) cells. The terms “base station” and “cell” may be used interchangeably herein.

[0042] Wireless communication network 100 may also include relay stations. A relay station is an entity that can receive a transmission of data from an upstream station (e.g., BS 110 or UE 120) and send a transmission of the data to a downstream station (e.g., UE 120 or BS 110). A relay station may also be a UE that can relay transmissions for other UEs. In the example shown in FIG. 1, relay station 110d may communicate with macro BS 110a and UE 120d in order to facilitate communication between BS 110a and UE 120d. A relay station may also be referred to as a relay BS, a relay, etc.

[0043] Wireless communication network 100 may be a heterogeneous network that includes BSs of different types, e.g., macro BSs, pico BSs, femto BSs, relay BSs, etc. These different types of BSs may have different transmit power levels, different coverage areas, and different impact on interference in wireless communication network 100. For example, macro BSs may have a high transmit power level (e.g., 5 to 40 Watts) whereas pico BSs, femto BSs, and relay BSs may have lower transmit power levels (e.g., 0.1 to 2 Watts).

[0044] Network controller 130 may couple to a set of BSs and may provide coordination and control for these BSs. Network controller 130 may communicate with

the BSs via a backhaul. The BSs may also communicate with one another, e.g., directly or indirectly via a wireless or wireline backhaul.

[0045] UEs 120 (e.g., UE 120a, UE 120b, UE 120c) may be dispersed throughout wireless communication network 100, and each UE may be stationary or mobile. A UE may also be referred to as an access terminal, a terminal, a mobile station, a subscriber unit, a station, a Customer Premises Equipment (CPE), etc. A UE may be a cellular phone (e.g., a smart phone), a personal digital assistant (PDA), a wireless modem, a wireless communication device, a handheld device, a laptop computer, a cordless phone, a wireless local loop (WLL) station, a tablet, a camera, a drone, a robot/robotic device, a netbook, a smartbook, an ultrabook, a medical device, medical equipment, a healthcare device, a biometric sensor/device, a wearable device such as a smart watch, smart clothing, smart glasses, virtual reality goggles, a smart wristband, and/or smart jewelry (e.g., a smart ring, a smart bracelet, etc.), an entertainment device (e.g., a music device, a video device, a gaming device, a satellite radio, etc.), industrial manufacturing equipment, a navigation/positioning device (e.g., GNSS (global navigation satellite system) devices based on, for example, GPS (global positioning system), Beidou, GLONASS, Galileo, terrestrial-based devices, etc.), or any other suitable device configured to communicate via a wireless or wired medium. Some UEs may be implemented as IoT (Internet of things) UEs. IoT UEs include, for example, robots/robotic devices, drones, remote devices, sensors, meters, monitors, cameras, location tags, etc., that may communicate with a BS, another device (e.g., remote device), or some other entity. IoT UEs may include MTC/eMTC UEs, NB-IoT UEs, as well as other types of UEs. A wireless node may provide, for example, connectivity for or to a network (e.g., a wide area network such as Internet or a cellular network) via a wired or wireless communication link.

[0046] One or more UEs 120 in the wireless communication network 100 (e.g., an LTE network) may be a narrowband bandwidth UE. As used herein, devices with limited communication resources, e.g. smaller bandwidth, may be referred to generally as narrowband UEs. Similarly, legacy devices, such as legacy and/or advanced UEs (e.g., in LTE) may be referred to generally as wideband UEs. Generally, wideband UEs are capable of operating on a larger amount of bandwidth than narrowband UEs.

[0047] In FIG. 1, a solid line with double arrows indicates desired transmissions between a UE and a serving BS, which is a BS designated to serve the UE on the downlink

and/or uplink. A dashed line with double arrows indicates potentially interfering transmissions between a UE and a BS.

[0048] In general, any number of wireless networks may be deployed in a given geographic area. Each wireless network may support a particular radio access technology (RAT) and may operate on one or more frequencies. A RAT may also be referred to as a radio technology, an air interface, etc. A frequency may also be referred to as a carrier, a frequency channel, etc. Each frequency may support a single RAT in a given geographic area in order to avoid interference between wireless networks of different RATs. In some cases, NR or 5G RAT networks may be deployed.

[0049] In some examples, access to the air interface may be scheduled, wherein a scheduling entity (e.g., a BS 110) allocates resources for communication among some or all devices and equipment within its service area or cell. The scheduling entity may be responsible for scheduling, assigning, reconfiguring, and releasing resources for one or more subordinate entities. For scheduled communication, subordinate entities utilize resources allocated by the scheduling entity. BSs 110 are not the only entities that may function as a scheduling entity. In some examples, UE 120 may function as a scheduling entity, scheduling resources for one or more subordinate entities (e.g., one or more other UEs 120). In this example, the UE is functioning as a scheduling entity, and other UEs utilize resources scheduled by the UE for wireless communication. A UE may function as a scheduling entity in a peer-to-peer (P2P) network, and/or in a mesh network. In a mesh network example, UEs may optionally communicate directly with one another in addition to communicating with the scheduling entity.

[0050] Thus, in a wireless communication network with a scheduled access to time-frequency resources and having a cellular configuration, a P2P configuration, and a mesh configuration, a scheduling entity and one or more subordinate entities may communicate utilizing the scheduled resources.

[0051] FIG. 2 shows a block diagram of a design of BS 110 and UE 120, which may be one of the BSs 110 and one of the UEs 120 in FIG. 1. BS 110 may be equipped with T antennas 234a through 234t, and UE 120 may be equipped with R antennas 252a through 252r, where in general $T \geq 1$ and $R \geq 1$.

[0052] At BS 110, transmit processor 220 may receive data from a data source 212 for one or more UEs, select one or more modulation and coding schemes (MCS) for each UE based on channel quality indicators (CQIs) received from the UE, process (e.g., encode and modulate) the data for each UE based on the MCS(s) selected for the UE, and provide data symbols for all UEs. Transmit processor 220 may also process system information (e.g., for static resource partitioning information (SRPI), etc.) and control information (e.g., CQI requests, grants, upper layer signaling, etc.) and provide overhead symbols and control symbols. Processor 220 may also generate reference symbols for reference signals (e.g., the cell-specific reference signal (CRS)) and synchronization signals (e.g., the primary synchronization signal (PSS) and the secondary synchronization signal (SSS)). Transmit (TX) multiple-input multiple-output (MIMO) processor 230 may perform spatial processing (e.g., precoding) on the data symbols, the control symbols, the overhead symbols, and/or the reference symbols, if applicable, and may provide T output symbol streams to T modulators (MODs) 232a through 232t. Each modulator 232 may process a respective output symbol stream (e.g., for OFDM, etc.) to obtain an output sample stream. Each modulator 232 may further process (e.g., convert to analog, amplify, filter, and upconvert) the output sample stream to obtain a downlink signal. T downlink signals from modulators 232a through 232t may be transmitted via T antennas 234a through 234t, respectively.

[0053] At UE 120, antennas 252a through 252r may receive the downlink signals from base station 110 and/or other BSs and may provide received signals to demodulators (DEMOS) 254a through 254r, respectively. Each demodulator 254 may condition (e.g., filter, amplify, downconvert, and digitize) its received signal to obtain input samples. Each demodulator 254 may further process the input samples (e.g., for OFDM, etc.) to obtain received symbols. MIMO detector 256 may obtain received symbols from all R demodulators 254a through 254r, perform MIMO detection on the received symbols if applicable, and provide detected symbols. Receive processor 258 may process (e.g., demodulate and decode) the detected symbols, provide decoded data for UE 120 to data sink 260, and provide decoded control information and system information to controller/processor 280. A channel processor may determine reference signal received power (RSRP), received signal strength indicator (RSSI), reference signal receive quality (RSRQ), CQI, etc.

[0054] On the uplink, at UE 120, transmit processor 264 may receive and process data from data source 262 and control information (e.g., for reports comprising RSRP, RSSI, RSRQ, CQI, etc.) from controller/processor 280. Processor 264 may also generate reference symbols for one or more reference signals. The symbols from transmit processor 264 may be precoded by TX MIMO processor 266 if applicable, further processed by modulators 254a through 254r (e.g., for SC-FDM, OFDM, etc.), and transmitted to BS 110. At BS 110, the uplink signals from UE 120 and other UEs may be received by antennas 234, processed by demodulators 232, detected by MIMO detector 236 if applicable, and further processed by receive processor 238 to obtain decoded data and control information sent by UE 120. Processor 238 may provide the decoded data to data sink 239 and the decoded control information to controller/processor 240. BS 110 may include communication unit 244 and communicate to network controller 130 via communication unit 244. Network controller 130 may include communication unit 294, controller/processor 290, and memory 292.

[0055] Controllers/processors 240 and 280 may direct the operation at BS 110 and UE 120, respectively, to perform techniques presented herein. For example, processor 240 and/or other processors and modules at BS 110, and processor 280 and/or other processors and modules at UE 120, may perform or direct operations of BS 110 and UE 120, respectively. For example, controller/processor 280 and/or other controllers/processors and modules at UE 120 may perform or direct operations 1500 shown in FIG. 15, operations 1600 shown in FIG. 16, and operations 1700 shown in FIG. 17. Memories 242 and 282 may store data and program codes for BS 110 and UE 120, respectively. Scheduler 246 may schedule UEs for data transmission on the downlink and/or uplink.

[0056] FIG. 3 shows an exemplary frame structure 300 for frequency division duplexing (FDD) in a wireless communication system (e.g., such as wireless communication network 100). The transmission timeline for each of the downlink and uplink may be partitioned into units of radio frames. Each radio frame may have a predetermined duration (e.g., 10 milliseconds (ms)) and may be partitioned into 10 subframes with indices of 0 through 9. Each subframe may include two slots. Each radio frame may thus include 20 slots with indices of 0 through 19. Each slot may include L symbol periods, for example, seven symbol periods for a normal cyclic prefix (as shown

in FIG. 3) or six symbol periods for an extended cyclic prefix. The $2L$ symbol periods in each subframe may be assigned indices of 0 through $2L-1$.

[0057] In certain wireless communication systems (e.g., LTE), a BS (e.g., such as BS 110) may transmit a PSS and a SSS on the downlink in the center of the system bandwidth for each cell supported by the BS. The PSS and SSS may be transmitted in symbol periods 6 and 5, respectively, in subframes 0 and 5 of each radio frame with the normal cyclic prefix, as shown in FIG. 3. The PSS and SSS may be used by UEs (e.g., such as UEs 120) for cell search and acquisition. The BS may transmit a CRS across the system bandwidth for each cell supported by the BS. The CRS may be transmitted in certain symbol periods of each subframe and may be used by the UEs to perform channel estimation, channel quality measurement, and/or other functions. The BS may also transmit a physical broadcast channel (PBCH) in symbol periods 0 to 3 in slot 1 of certain radio frames. The PBCH may carry some system information. The BS may transmit other system information such as system information blocks (SIBs) on a physical downlink shared channel (PDSCH) in certain subframes. The BS may transmit control information/data on a physical downlink control channel (PDCCH) in the first B symbol periods of a subframe, where B may be configurable for each subframe. The BS may transmit traffic data and/or other data on the PDSCH in the remaining symbol periods of each subframe.

[0058] In certain systems (e.g., such as NR or 5G systems), a BS may transmit these or other signals in these locations or in different locations of the subframe.

[0059] FIG. 4 shows two exemplary subframe formats 410 and 420 with the normal cyclic prefix. The available time frequency resources may be partitioned into resource blocks (RBs). Each RB may cover 12 subcarriers in one slot and may include a number of resource elements (REs). Each RE may cover one subcarrier in one symbol period and may be used to send one modulation symbol, which may be a real or complex value.

[0060] Subframe format 410 may be used for two antennas. A CRS may be transmitted from antennas 0 and 1 in symbol periods 0, 4, 7 and 11. A reference signal is a signal that is known *a priori* by a transmitter and a receiver and may also be referred to as pilot. A CRS is a reference signal that is specific for a cell, e.g., generated based on a cell identity (ID). In FIG. 4, for a given RE with label Ra, a modulation symbol may be

transmitted on that RE from antenna a , and no modulation symbols may be transmitted on that RE from other antennas. Subframe format 420 may be used with four antennas. A CRS may be transmitted from antennas 0 and 1 in symbol periods 0, 4, 7 and 11 and from antennas 2 and 3 in symbol periods 1 and 8. For both subframe formats 410 and 420, a CRS may be transmitted on evenly spaced subcarriers, which may be determined based on cell ID. CRSs may be transmitted on the same or different subcarriers, depending on their cell IDs. For both subframe formats 410 and 420, REs not used for the CRS may be used to transmit data (e.g., traffic data, control data, and/or other data).

[0061] The PSS, SSS, CRS and PBCH in LTE are described in 3GPP TS 36.211, entitled "Evolved Universal Terrestrial Radio Access (E-UTRA); Physical Channels and Modulation," which is publicly available.

[0062] An interlace structure may be used for each of the downlink and uplink for FDD in LTE. For example, Q interlaces with indices of 0 through $Q - 1$ may be defined, where Q may be equal to 4, 6, 8, 10, or some other value. Each interlace may include subframes that are spaced apart by Q frames. In particular, interlace q may include subframes $q, q + Q, q + 2Q$, etc., where $q \in \{0, \dots, Q-1\}$.

[0063] The wireless network may support hybrid automatic retransmission request (HARQ) for data transmission on the downlink and uplink. For HARQ, a transmitter (e.g., a BS) may send one or more transmissions of a packet until the packet is decoded correctly by a receiver (e.g., a UE) or some other termination condition is encountered. For synchronous HARQ, all transmissions of the packet may be sent in subframes of a single interlace. For asynchronous HARQ, each transmission of the packet may be sent in any subframe.

[0064] A UE may be located within the coverage of multiple BS. One of these BSs may be selected to serve the UE. The serving BS may be selected based on various criteria such as received signal strength, received signal quality, pathloss, etc. Received signal quality may be quantified by a signal-to-noise-and-interference ratio (SINR), or a RSRQ, or some other metric. The UE may operate in a dominant interference scenario in which the UE may observe high interference from one or more interfering BS.

[0065] The wireless communication network may support a 180 kHz deployment for

narrowband operation (e.g., NB-IoT) with different deployment modes. In one example, narrowband operations may be deployed in-band, for example, using RBs within a wider system bandwidth. In one case, narrowband operations may use one RB within the wider system bandwidth of an existing network (e.g., such as an LTE network). In this case, the 180 kHz bandwidth for the RB may have to be aligned with a wideband RB. In one example, narrowband operations may be deployed in the unused RBs within a carrier guard-band (e.g., LTE). In this deployment, the 180 kHz RB within the guard band may be aligned with a 15 kHz tone grid of wideband LTE, for example, in order to use the same Fast Fourier Transform (FFT) and/or reduce interference in-band legacy LTE communications.

Example Narrowband Communications

[0066] The focus of traditional LTE design (e.g., for legacy “non MTC” devices) is on the improvement of spectral efficiency, ubiquitous coverage, and enhanced quality of service (QoS) support. Current LTE system downlink (DL) and uplink (UL) link budgets are designed for coverage of high end devices, such as state-of-the-art smartphones and tablets, which may support a relatively large DL and UL link budget.

[0067] However, as described above, one or more UEs in the wireless communication network (e.g., wireless communication network 100) may be devices that have limited communication resources, such as narrowband UEs, as compared to other (wideband) devices in the wireless communication network. For narrowband UEs, various requirements may be relaxed as only a limited amount of information may need to be exchanged. For example, maximum bandwidth may be reduced (relative to wideband UEs), a single receive radio frequency (RF) chain may be used, peak rate may be reduced (e.g., a maximum of 100 bits for a transport block size), transmit power may be reduced, Rank 1 transmission may be used, and half duplex operation may be performed.

[0068] In some cases, if half-duplex operation is performed, MTC UEs may have a relaxed switching time to transition from transmitting to receiving (or receiving to transmitting). For example, the switching time may be relaxed from 20 μ s for regular UEs to 1ms for MTC UEs. Release 12 MTC UEs may still monitor downlink (DL) control channels in the same way as regular UEs, for example, monitoring for wideband control channels in the first few symbols (e.g., PDCCH) as well as narrowband control channels

occupying a relatively narrowband, but spanning a length of a subframe (e.g., enhanced PDCCH or ePDCCH).

[0069] Certain standards (e.g., LTE Release 13) may introduce support for various additional MTC enhancements, referred to herein as enhanced MTC (or eMTC). For example, eMTC may provide MTC UEs with coverage enhancements up to 15dB.

[0070] As illustrated in the subframe structure 500 of FIG. 5, eMTC UEs can support narrowband operation while operating in a wider system bandwidth (e.g., 1.4/3/5/10/15/20MHz). In the example illustrated in FIG. 5, a conventional legacy control region 510 may span system bandwidth of a first few symbols, while a narrowband region 530 of the system bandwidth (spanning a narrow portion of a data region 520) may be reserved for an MTC physical downlink control channel (referred to herein as an M-PDCCH) and for an MTC physical downlink shared channel (referred to herein as an M-PDSCH). In some cases, an MTC UE monitoring the narrowband region may operate at 1.4MHz or 6 resource blocks (RBs).

[0071] However, as noted above, eMTC UEs may be able to operate in a cell with a bandwidth larger than 6 RBs. Within this larger bandwidth, each eMTC UE may still operate (e.g., monitor/receive/transmit) while abiding by a 6-physical resource block (PRB) constraint. In some cases, different eMTC UEs may be served by different narrowband regions (e.g., with each spanning 6-PRB blocks). As the system bandwidth may span from 1.4 to 20 MHz, or from 6 to 100 RBs, multiple narrowband regions may exist within the larger bandwidth. An eMTC UE may also switch or hop between multiple narrowband regions in order to reduce interference.

Example Narrowband Internet-of-Things

[0072] The Internet-of-Things (IoT) may refer to a network of physical objects, devices, or “things”. IoT devices may be embedded with, for example, electronics, software, or sensors and may have network connectivity, which enable these devices to collect and exchange data. IoT devices may be sensed and controlled remotely across existing network infrastructure, creating opportunities for more direct integration between the physical world and computer-based systems and resulting in improved efficiency, accuracy, and economic benefit. Systems that include IoT devices augmented with

sensors and actuators may be referred to cyber-physical systems. Cyber-physical systems may include technologies such as smart grids, smart homes, intelligent transportation, and/or smart cities. Each “thing” (e.g., IoT device) may be uniquely identifiable through its embedded computing system may be able to interoperate within existing infrastructure, such as Internet infrastructure.

[0073] NB-IoT may refer to a narrowband radio technology specially designed for the IoT. NB-IoT may focus on indoor coverage, low cost, long battery life, and large number of devices. To reduce the complexity of UEs, NB-IoT may allow for narrowband deployments utilizing one PRB (e.g., 180 kHz + 20 kHz guard band). NB-IoT deployments may utilize higher layer components of certain systems (e.g., LTE) and hardware to allow for reduced fragmentation and cross compatibility with, for example, NB-LTE/NB-IoT and/or eMTC.

[0074] FIG. 6 illustrates an example deployment 600 of NB-IoT, according to certain aspects of the present disclosure. Three NB-IoT deployment configurations include in-band, guard-band, and standalone. For the in-band deployment configuration, NB-IoT may coexist with a legacy system (e.g., GSM, WCDMA, and/or LTE system(s)) deployed in the same frequency band. For example, the wideband LTE channel may be deployed in various bandwidths between 1.4 MHz to 20 MHz. As shown in FIG. 6, a dedicated RB 602 within that bandwidth may be available for use by NB-IoT and/or the RBs 1204 may be dynamically allocated for NB-IoT. As shown in FIG. 6, in an in-band deployment, one RB, or 200 kHz, of a wideband channel (e.g., LTE) may be used for NB-IoT.

[0075] Certain systems (e.g., LTE) may include unused portions of the radio spectrum between carriers to guard against interference between adjacent carriers. In some deployments, NB-IoT may be deployed in a guard band 606 of the wideband channel.

[0076] In other deployments, NB-IoT may be deployed standalone (not shown). In a standalone deployment, for example, one 200 MHz carrier may be utilized to carry NB-IoT traffic and GSM spectrum may be reused.

[0077] Deployments of NB-IoT may include synchronization signals such as PSS for frequency and timing synchronization and SSS to convey system information. For NB-

IoT operations, PSS/SSS timing boundaries may be extended as compared to the existing PSS/SSS frame boundaries in legacy systems (e.g., LTE), for example, from 10 ms to 40 ms. Based on the timing boundary, a UE is able to receive a PBCH transmission, which may be transmitted in subframe 0 of a radio frame.

Example NR/5G RAN Architecture

[0078] New radio (NR) may refer to radios configured to operate according to a new air interface (e.g., other than Orthogonal Frequency Divisional Multiple Access (OFDMA)-based air interfaces) or fixed transport layer (e.g., other than Internet Protocol (IP)). NR may utilize OFDM with a CP on the uplink and downlink and include support for half-duplex operation using TDD. NR may include Enhanced Mobile Broadband (eMBB) service targeting wide bandwidth (e.g. 80 MHz beyond), millimeter wave (mmW) targeting high carrier frequency (e.g. 60 GHz), massive MTC (mMTC) targeting non-backward compatible MTC techniques, and/or mission critical targeting ultra reliable low latency communications (URLLC) service.

[0079] A single component carrier (CC) bandwidth of 100 MHz may be supported. NR RBs may span 12 sub-carriers with a sub-carrier bandwidth of 75 kHz over a 0.1 ms duration. Each radio frame may consist of 50 subframes with a length of 10 ms. Consequently, each subframe may have a length of 0.2 ms. Each subframe may indicate a link direction (e.g., DL or UL) for data transmission and the link direction for each subframe may be dynamically switched. Each subframe may include DL/UL data as well as DL/UL control data. UL and DL subframes for NR may be as described in more detail below with respect to FIGs. 9 and 10.

[0080] Beamforming may be supported and beam direction may be dynamically configured. MIMO transmissions with precoding may also be supported. MIMO configurations in the DL may support up to 8 transmit antennas with multi-layer DL transmissions up to 8 streams and up to 2 streams per UE. Multi-layer transmissions with up to 2 streams per UE may be supported. Aggregation of multiple cells may be supported with up to 8 serving cells. Alternatively, NR may support a different air interface, other than an OFDM-based interface. NR networks may include entities such central units (CUs) or distributed units (DUs).

[0081] The NR RAN may include a CU and DUs. A NR BS (e.g., a NB, an eNB, a gNB, a 5G NB, a TRP, an AP, etc.) may correspond to one or multiple BSs. NR cells can be configured as access cells (ACells) or data only cells (DCells). For example, the RAN (e.g., a CU or DU) can configure the cells. DCells may be cells used for carrier aggregation or dual connectivity, but not used for initial access, cell selection/reselection, or handover. In some cases DCells may not transmit synchronization signals—in some case cases DCells may transmit synchronization signals.

[0082] FIG. 7 illustrates an example logical architecture 700 of a distributed RAN, according to aspects of the present disclosure. 5G access node 706 may include access node controller (ANC) 702. ANC 702 may be a CU of the distributed RAN. The backhaul interface to the next generation core network (NG-CN) 704 may terminate at ANC 702. The backhaul interface to neighboring next generation access nodes (NG-ANs) 710 may terminate at ANC 702. ANC 702 may include one or more TRPs 708. As described above, TRP may be used interchangeably with “cell”, BS, NR BS, NB, eNB, 5G NB, gNB, AP, etc.

[0083] TRPs 708 may comprise a DU. TRPs 708 may be connected to one ANC (e.g., ANC 702) or more than one ANC (not illustrated). For example, for RAN sharing, radio as a service (RaaS), and service specific AND deployments, TRP 708 may be connected to more than one ANC. TRP 708 may include one or more antenna ports. TRPs 708 may be configured to individually (e.g., dynamic selection) or jointly (e.g., joint transmission) serve traffic to a UE.

[0084] Logical architecture 700 may be used to illustrate fronthaul definition. The architecture may be defined that support fronthauling solutions across different deployment types. For example, logical architecture 700 may be based on transmit network capabilities (e.g., bandwidth, latency, and/or jitter). Logical architecture 700 may share features and/or components with LTE. According to aspects, NG-AN 710 may support dual connectivity with NR. NG-AN 710 may share a common fronthaul for LTE and NR. Logical architecture 700 may enable cooperation between and among TRPs 708. For example, cooperation may be preset within a TRP and/or across TRPs via ANC 702. In some cases, no inter-TRP interface may be needed/present.

[0085] A dynamic configuration of split logical functions may be present within

logical architecture 700. The packet data convergence protocol (PDCP), radio link control (RLC), and medium access control (MAC) protocols may be adaptably placed at ANC 702 or TRP 708.

[0086] FIG. 8 illustrates an example physical architecture 800 of a distributed RAN, according to aspects of the present disclosure. Centralized core network unit (C-CU) 802 may host core network functions. C-CU 802 may be centrally deployed. C-CU 802 functionality may be offloaded (e.g., to advanced wireless services (AWS)), in an effort to handle peak capacity.

[0087] Centralized RAN unit (C-RU) 804 may host one or more ANC functions. Optionally, C-RU 804 may host core network functions locally. C-RU 804 may have distributed deployment. C-RU 804 may be closer to the network edge.

[0088] DU 806 may host one or more TRPs. DU 806 may be located at edges of the network with radio frequency (RF) functionality.

[0089] FIG. 9 is a diagram showing an example of a DL-centric subframe 900. DL-centric subframe 900 may include control portion 902. Control portion 902 may exist in the initial or beginning portion of DL-centric subframe 900. Control portion 902 may include various scheduling information and/or control information corresponding to various portions of DL-centric subframe 900. In some configurations, control portion 902 may be a physical DL control channel (PDCCH), as shown in FIG. 9. DL-centric subframe 900 may also include DL data portion 904. DL data portion 904 may sometimes be referred to as the payload of DL-centric subframe 900. DL data portion 904 may include the communication resources utilized to communicate DL data from the scheduling entity (e.g., UE or BS) to the subordinate entity (e.g., UE). In some configurations, DL data portion 904 may be a physical DL shared channel (PDSCH).

[0090] DL-centric subframe 900 may also include common UL portion 906. Common UL portion 906 may sometimes be referred to as an UL burst, a common UL burst, and/or various other suitable terms. Common UL portion 906 may include feedback information corresponding to various other portions of DL-centric subframe 900. For example, common UL portion 906 may include feedback information corresponding to control portion 902. Non-limiting examples of feedback information

may include an acknowledgment (ACK) signal, a negative acknowledgment (NACK) signal, a HARQ indicator, and/or various other suitable types of information. Common UL portion 906 may include additional or alternative information, such as information pertaining to random access channel (RACH) procedures, scheduling requests (SRs), and various other suitable types of information. As illustrated in FIG. 9, the end of DL data portion 904 may be separated in time from the beginning of common UL portion 906. This time separation may sometimes be referred to as a gap, a guard period, a guard interval, and/or various other suitable terms. This separation provides time for the switch-over from DL communication (e.g., reception operation by the subordinate entity) to UL communication (e.g., transmission by the subordinate entity). One of ordinary skill in the art will understand that the foregoing is merely one example of a DL-centric subframe and alternative structures having similar features may exist without necessarily deviating from the aspects described herein.

[0091] FIG. 10 is a diagram showing an example of an UL-centric subframe 1000. UL-centric subframe 1000 may include control portion 1002. Control portion 1002 may exist in the initial or beginning portion of UL-centric subframe 1000. Control portion 1002 in FIG. 10 may be similar to control portion 1002 described above with reference to FIG. 9. UL-centric subframe 1000 may also include UL data portion 1004. UL data portion 1004 may sometimes be referred to as the payload of UL-centric subframe 1000. The UL portion may refer to the communication resources utilized to communicate UL data from the subordinate entity (e.g., UE) to the scheduling entity (e.g., UE or BS). In some configurations, control portion 1002 may be a PDCCH. In some configurations, the data portion may be a physical uplink shared channel (PUSCH).

[0092] As illustrated in FIG. 10, the end of control portion 1002 may be separated in time from the beginning of UL data portion 1004. This time separation may sometimes be referred to as a gap, guard period, guard interval, and/or various other suitable terms. This separation provides time for the switch-over from DL communication (e.g., reception operation by the scheduling entity) to UL communication (e.g., transmission by the scheduling entity). UL-centric subframe 1000 may also include common UL portion 1006. Common UL portion 1006 in FIG. 10 may be similar to common UL portion 906 described above with reference to FIG. 9. Common UL portion 1006 may additionally or alternatively include information pertaining to CQI, sounding reference signals (SRSS),

and various other suitable types of information. One of ordinary skill in the art will understand that the foregoing is merely one example of an UL-centric subframe and alternative structures having similar features may exist without necessarily deviating from the aspects described herein.

[0093] In some circumstances, two or more subordinate entities (e.g., UEs) may communicate with each other using sidelink signals. Real-world applications of such sidelink communications may include public safety, proximity services, UE-to-network relaying, vehicle-to-vehicle (V2V) communications, Internet of Everything (IoE) communications, IoT communications, mission-critical mesh, and/or various other suitable applications. Generally, a sidelink signal may refer to a signal communicated from one subordinate entity (e.g., UE1) to another subordinate entity (e.g., UE2) without relaying that communication through the scheduling entity (e.g., UE or BS), even though the scheduling entity may be utilized for scheduling and/or control purposes. In some examples, the sidelink signals may be communicated using a licensed spectrum (unlike wireless local area networks, which typically use an unlicensed spectrum).

[0094] A UE may operate in various radio resource configurations, including a configuration associated with transmitting pilots using a dedicated set of resources (e.g., a RRC dedicated state, etc.) or a configuration associated with transmitting pilots using a common set of resources (e.g., an RRC common state, etc.). When operating in the RRC dedicated state, the UE may select a dedicated set of resources for transmitting a pilot signal to a network. When operating in the RRC common state, the UE may select a common set of resources for transmitting a pilot signal to the network. In either case, a pilot signal transmitted by the UE may be received by one or more network access devices, such as an AN, a DU, or portions thereof. Each receiving network access device may be configured to receive and measure pilot signals transmitted on the common set of resources, and also receive and measure pilot signals transmitted on dedicated sets of resources allocated to the UEs for which the network access device is a member of a monitoring set of network access devices for the UE. One or more of the receiving network access devices, or a CU to which receiving network access device(s) transmit the measurements of the pilot signals, may use the measurements to identify serving cells for the UEs, or to initiate a change of serving cell for one or more of the UEs.

EXAMPLE UPLINK AND DOWNLINK GRANTS FOR NARROWBAND

[0095] As mentioned above, certain systems (e.g., Release 13 or later eMTC systems), may support narrowband operation. For example, the narrowband operation may include support for communications on a 6 RB band and half-duplex operation (e.g., capability to transmit and receive, but not both simultaneously) for up to, e.g., 15 dB coverage enhancements. These systems may reserve a portion of the system bandwidth for control, which may be an MTC physical downlink control channel (MPDCCH). The MPDCCH may be transmitted in a narrowband, may use at least one subframe, and may rely on demodulation reference signal (DMRS) demodulation for decoding of the control channel. Coverage may be increased by performing repetition/bundling of signals.

[0096] Certain systems (e.g., Release 13 or later NB-IoT systems) may support narrowband Internet-of-things operation (NB-IOT). NB-IoT may use 180 kHz bandwidth. NB-IoT may offer standalone, in-band, or guard band deployment scenarios. Standalone deployment may use new bandwidth, whereas guard band deployment may be done using bandwidth typically reserved in the guard band of an existing network, such as long term evolution (LTE). In-band deployment on the other hand may use the same resource blocks in the LTE carrier of the existing LTE network. NB-IoT may offer increased coverage. NB-IoT may define a new narrowband control channel (e.g., Narrowband PDCCH (NPDCCH)), data, and references signals that fit in 1 RB. For clarity, certain aspects of the techniques are described below for NB-IoT, and NB-IoT terminology is used in much of the description below.

[0097] Currently, in certain systems such as NB-IoT, only half-duplex (HD) FDD (frequency division duplex) operation is supported. A UE cannot monitor both UL and DL at the same time and is not required to support parallel UL and DL transmissions. The rules of timing limitation are defined so that the gap between NPDCCH for UL grant and the associated NPUSCH (narrowband PUSCH) transmission is at least 8ms (e.g., exact delay is determined by a field in the UL grant) and the gap between the NPDCCH for DL grant and the associated NPDSCH (narrowband PDSCH) is at least 5ms (e.g., exact delay is determined by a field in the DL grant). NPUSCH and NPDSCH are examples of shared channels or data channels. Depending on the context, "channel" may refer to the channel on which signaling/data/information is transmitted or received, or to the signaling/data/information that is transmitted or received on the channel. In Rel-13, only a single HARQ process is supported in NB-IoT. After receiving one NPDCCH for

DL grant or UL grant, UE stops monitoring the NPDCCH until finishing the data transmission. In Rel-14, for NB-IoT, it is possible to have two DL grants back to back or two UL grants back to back for two HARQ processes, e.g., after receiving one DL or UL grant, UE may be required to continue monitoring any NPDCCH search space containing candidates ending at least 2 ms ($x_1 \geq 2$ ms) before the start of the first NPDSCH or NPUSCH.

[0098] Figure 11 illustrates an example of Release 13 HARQ process timing and an example of Release 14 HARQ process timing. As illustrated for Release 13, the time gap between a NPDCCH for DL grant and an associated NPDSCH is 5ms or more. After receiving the NPDCCH, UE stops monitoring for NPDCCH, and after 5ms or more, UE starts receiving downlink transmission (e.g., data transmission, such as repetition data transmission to improve coverage) on NPDSCH. After receiving the data transmission, UE transmits ACK information after 12ms or more. For the uplink example, UE receives NPDCCH for UL grant, stops monitoring for NPDCCH, and transmits (e.g., data transmission) on uplink on the associated NPUSCH after 8ms or more. As illustrated for Release 14, UE is required to continue monitor for a second NPDCCH (NPDCCH2) after receiving a first NPDCCH (NPDCCH1). UE monitors for the second NPDCCH until 2ms or more before the start of the NPDSCH (NPDSCH1) transmission associated with the first NPDCCH. As illustrated for Release 14, the two back to back NPDCCHs are either both for DL grant or both for UL grant. In other words, UE receives two consecutive UL grants or two consecutive DL grants. Receiving consecutive UL grants comprises receiving a UL grant as the next grant after a UL grant, and receiving consecutive DL grants comprises receiving a DL grant as the next grant after a DL grant.

[0099] Unlike HD-FDD, for TDD, the DL and UL subframes can interlace during NPUSCH/NPDSCH transmission. For supporting NB-IoT TDD DL and UL transmission, UE may receive some DL subframes for a DL packet (e.g., associated with NPDCCH for DL grant), followed by UL transmission for an UL packet (e.g., associated with NPDCCH for UL grant), then followed by repetition for the same DL packet, followed again by some repetitions of the same UL packet, and so on.

[00100] Per Rel-14 specification, an UE may only receive two DL grants back to back or two UL grants back to back for NB-IoT, and receiving interlaced UL and DL grants by a UE is not supported. For Rel-15, extending NB-IoT to TDD mode may be discussed.

For TDD, parallel uplink and downlink transmission means, for example, UE receives DL transmission of DL packet followed by UL transmission of a UL packet, followed by repetition of the same DL packet followed by repetition of same UL packet. To support this interlaced DL/UL transmission, the DL/UL grants would also need to be interlaced, and this feature is not supported by the current standard specification. Receiving interlaced UL and DL grants comprises receiving a DL grant as the next grant after an UL grant, or receiving an UL grant as the next grant after a DL grant. Interlacing UL and DL grants is needed in order to support interlacing UL and DL transmission, especially for TDD. Interlacing UL and DL grants may also be beneficial for FDD, for example, to improve UL/DL transmission efficiency (e.g., for some current TDM-based applications, for UL data transmission, may need to finish DL data transmission first).

[00101] Interlaced UL and DL grants can be supported so that an UE can receive two grants, one for UL and one for DL, before the start of the corresponding NPUSCH or NPDSCH transmission. The rules of timing limitation between NPDCCH and NPDSCH/NPUSCH can be unchanged. For example, the gap between the 2nd NPDCCH to the start of NPDSCH or NPUSCH may be ≥ 2 ms. Additionally, for HD-FDD, an UE is not required to monitor the NPDCCH (e.g., for a third grant) between the start of NPDSCH to HARQ-ACK. This simplifies UE implementation and conserves UE power because otherwise the UE would need to receive DL control information in addition to receiving data at the same time. In an aspect, there is no restriction on the order of interlaced UL and DL grants, e.g., the first grant can be either UL or DL grant.

[00102] Figure 12 illustrates example interlaced grants (DL followed by UL) in accordance with certain aspects of the present disclosure. In one example, first grant is UL grant and second grant is DL grant. Time delay from a grant to the associated data transmission may be the same as described above (e.g., 8ms or more between UL grant and associated NPUSCH transmission, 5ms or more between DL grant and associated NPDSCH transmission). In this example, UL data transmission (e.g., on NPUSCH) takes place between DL data transmission (e.g., on NPDSCH) and the HARQ-ACK associated with the DL data transmission. In the second example, the order of data transmission is different. Here, the UL data transmission (e.g., on NPUSCH) takes place before DL data transmission (e.g., on NPDSCH). In the third example, UL data transmission (e.g., on NPUSCH) takes place after HARQ-ACK associated with the DL data transmission (e.g.,

on NPDSCH). Therefore, the order of data transmission is determined by, for example, the delay between the NPDCCH and the associated data transmission (e.g., determined by a field in NPDCCH).

[00103] Figure 13 illustrates example interlaced grants (UL followed by DL) in accordance with certain aspects of the present disclosure. Figure 13 illustrates similar concepts as Figure 12.

[00104] For NB-IoT in TDD mode, NPUSCH and NPDCCH interlacing may be supported, e.g., an UE can continue to monitor the NPDCCH search space when doing NPUSCH transmission. Due to TDD UL-DL configuration, there may be some DL subframes (SFs) between UL transmission, and UE may switch from UL transmission (e.g., NPUSCH transmission) to monitoring NPDCCH search space during the DL SFs. In an aspect, if subframes are indicated as DL according to TDD UL-DL configuration, an UE may be required to continue to monitor the search space unless the DL subframe is used for NPDSCH. If a guard subframe is needed to switch from UL to DL or from DL to UL, then the DL or UL communication associated with the guard subframe (e.g., the communication scheduled to take place during the guard subframe) may be postponed to a next available SF in case of interlacing DL and UL data transmission. If a few OFDM symbols are needed to switch from UL to DL or from DL to UL, then for example the associated DL or UL communication in the subframe may be punctured in the case of interlacing DL and UL data transmission. For example, when the switch is from UL to DL, then the first two symbols in a second subframe (DL) may be punctured, and when the switch is from DL to UL, then the last symbol in the first subframe (DL) and the first symbol in the second subframe (UL) may be punctured.

[00105] Figure 14 illustrates example interlaced NPDCCH and NPUSCH in accordance with certain aspects of the present disclosure. In this example, TDD UL-DL configuration 1 is illustrated. First, NPDCCH (NPDCCH1) for UL grant is received by UE. Based on the UL grant, a set of repetitions of uplink data transmission (e.g., for enhanced coverage) may be sent on NPUSCH. As illustrated, the number of repetitions is 8 (e.g., 8 subframes). Due to TDD frame structure, there may be some DL subframes between repetitions of the uplink data on NPUSCH. Normally, UE does not utilize these DL subframes between NPUSCH transmissions because it would not be efficient. In one aspect of the present disclosure, these DL SFs may be utilized to monitor for NPDCCH.

In this example, a guard subframe is used for switching from UL to DL so that a first DL subframe may serve as a guard subframe (indicated by “G” in Figure 14) and a second, adjacent DL subframe may be used for NPDCCH (e.g., NPDCCH2). If a few OFDM symbols are used for switching from UL to DL, then there is no need for guard subframes and the second NPDCCH (NPDCCH2) can be transmitted in the DL subframe right after the UL subframe.

[00106] Interlaced UL/DL grants can be supported with or without two HARQ processes support. If interlacing UL and DL grants is supported with two HARQ processes, up to 4 NPDCCHs can be received, e.g., two for DL and two for UL grants. In case of back-to-back DL grants or UL grants, the two grants could have same or different HARQ IDs. Same HARQ IDs may mean repetition transmission (e.g., retransmission of a first NPDCCH). For different HARQ IDs, the two HARQ IDs may appear in any order, or the first grant may always have HARQ ID 0 and second grant HARQ ID 1 (e.g., fixed order). If UE detects two grants with the same HARQ ID (e.g., two NPDCCHs associated with the same data), UE can discard one of them; for example, A) discard the one with lowest energy; B) always discard either the first one or the second one; or C) combination of the two, e.g., always discard first one if both have energy above some threshold. In another aspect, an UE honors both grants treating them as HARQ retransmissions. UE’s support of interlacing UL and DL grants can be separate, or independent from its support of two HARQ processes (e.g., UE can support interlacing UL and DL grants, or two HARQ processes, or both). The support of interlacing UL and DL grants may be indicated separately by an UE for the support of two HARQ processes. For example, UE may indicate the support of interlacing UL and DL grants using capability signaling and indicate the support of two HARQ processes independently (e.g., using different capability signaling) when it attaches to a network.

[00107] As one aspect of the current disclosure, example timelines for two HARQ processes are shown below.

[00108] Timeline 1 : NPDCCH1 NPDCCH2 NPDSCHA ACKA NPDSCHB ACKB

[00109] Timeline 2 : NPDCCH1 NPDCCH2 NPDSCHA NPDSCHB ACKA ACKB

[00110] In one aspect, only one of these timelines are allowed (e.g., fixed timing). In

another aspect, both timelines are allowed. For NPDCCH to NPDSCH mapping, in an aspect, NPDSCH A may always map to NPDCCH 1 and NPDSCH B may always map to NPDCCH2, and other mappings may be treated as error case and UE may discard one of the grants. In another aspect, both mappings (e.g., NPDSCHA to NPDCCH1 or NPDCCH 2) are allowed.

[00111] Thus, techniques for uplink and downlink grants in narrowband operations are desirable. Accordingly, techniques presented herein may be used for uplink and downlink grants in narrowband operations (e.g., NB-IoT).

[00112] FIG. 15 is a flow diagram illustrating example operations 1500 for receiving interlaced UL and DL grants, according to aspects described herein. Operations 1500 may be performed, for example, by a UE (e.g., UE 120) which may be a low cost, IoT device, such as an NB-IoT device. Operations 1500 may begin, at 1502, by monitoring a control channel in a narrowband of a system bandwidth for an uplink (UL) or a downlink (DL) grant. At 1504, the UE receives interlaced UL and DL grants. At 1506, the UE sends or receives information in response to the received interlaced UL and DL grants. In an aspect, the UE may monitor control channel search space and receive a DL grant as the next grant after the UL grant and after start of the sending information on an uplink data channel in response to the UL grant. In an aspect, the uplink data channel may be on a different carrier as the control channel search space. In an aspect, the uplink data channel may be an uplink shared channel. The uplink shared channel, for example, may be a narrowband physical uplink shared channel (NPUSCH).

[00113] FIG. 16 is a flow diagram illustrating example operations 1600 for UE behavior when receiving back to back UL grants or DL grants with same HARQ IDs, according to aspects described herein. Operations 1600 may be performed, for example, by a UE (e.g., UE 120) which may be a low cost, IoT device, such as an NB-IoT device. Operations 1600 may begin, at 1602, by monitoring a control channel in a narrowband of a system bandwidth for an uplink (UL) or a downlink (DL) grant. At 1604, the UE receives two consecutive UL or DL grants, wherein the consecutive UL or DL grants have a same HARQ process identification (ID). At 1606, the UE selects one of the grants to use, based, at least in part, on at least one of: the grant meeting an energy metric threshold; the grant being received first; or the grant being received second. At 1608, the UE can alternatively select both grants to use, wherein the grants are treated as HARQ

retransmissions.

Example UL and/or DL Collision Handling

[00114] With two HARQ processes being configured it is possible that eNB may schedule a UE such that there are collisions across channels, e.g., through incorrect scheduling. A collision may occur, e.g., when two or more sets of information are transmitted or received on the same resource (e.g., subframe) simultaneously. For example, it is possible for a UE to have two back to back NPDSCHs whose ACKs collide or have the second NPDSCH collide with ACK for the first NPDSCH, etc. For back to back NPUSCHs, there may be similar types of collisions. If interlaced UL and DL grants are implemented, there may also be collisions of NPUSCH with NPDSCH, NPUSCH with ACK, etc. Example UE behavior in case of such collisions is illustrated herein and may be applicable to TDD and/or FDD.

Collision handling for back-to-back DL grants or UL grants

[00115] FIG. 17 is a flow diagram illustrating example operations 1700 for UE behavior in connection with collisions when receiving back to back UL grants or DL grants, according to aspects described herein. Operations 1700 may be performed, for example, by a UE (e.g., UE 120) which may be a low cost, IoT device, such as an NB-IoT device. Operations 1700 may begin, at 1702, by monitoring a control channel in a narrowband of a system bandwidth for an uplink (UL) or a downlink (DL) grant. At 1704, the UE receives two consecutive UL or DL grants. At 1706, the UE sends or receives information in response to the received two consecutive UL and DL grants. At 1708, in response to the sending or receiving information, the UE identifies a collision, the collision comprising at least one of: collision between first DL data channel and second DL data channel, collision between the second DL data channel and first HARQ acknowledgement (HARQ-ACK) signaling for the first DL data channel, collision between first HARQ-ACK signaling for the first DL data channel and second HARQ-ACK signaling for the second DL data channel, or collision between first UL data channel and second UL data channel.

[00116] In the case of NPDSCH to NPDSCH collision, in one aspect, even though there are collisions, both NPDSCHs may be treated as valid NPDSCHs and attempt may be made to decode using 1) non-colliding subframes in both NPDSCHs (e.g., UE decodes

both of them) or 2) colliding SFs only for one of the NPDSCH (e.g., UE decodes only one of the two, the first one, the second one, or based on associated control channel energy metrics). In another aspect, only one of the NPDSCHs may be monitored – e.g., the first NPDSCH, or the second NPDSCH, or based on the corresponding NPDCCH energy metrics (e.g., associated control channel energy detection). The first NPDSCH may refer to the NPDSCH starting first or whose NPDCCH started first, and the second NPDSCH may refer to the NPDSCH starting second or whose NPDCCH started second.

[00117] In the case of NPDSCH to ACK collision (e.g., ACK for a first NPDSCH is colliding with a second NPDSCH), in one aspect, treat it as incorrect grant and drop one of the NPDSCH and corresponding ACK (similar to NPDSCH to NPDSCH collision). In another aspect, ACK may be dropped. (entirely or partly, e.g., on colliding subframes). In another aspect, NPDSCH may be dropped (entirely or partly, e.g., on colliding subframes). Colliding SFs could include SFs containing ACK/NPDSCH as well as guard SFs for switch from UL to DL, etc.

[00118] In the case of ACK to ACK collision, in one aspect, treat it as incorrect grant and drop one of the NPDSCHs (similar to NPDSCH to NPDSCH collision) or ACKs. In another aspect, send only the first or second ACK. In another aspect, send first ACK fully, and puncture the second ACK, or vice-versa. If only one NPDSCH decodes successfully, ACK corresponding to that NPDSCH may be sent, and for the failed NPDSCH, the ACK transmission corresponding to the failed NPDSCH may be punctured.

[00119] In the case of NPUSCH to NPUSCH collision, in one aspect, one of the NPUSCHs may be dropped. In another aspect, one of the NPUSCHs may be punctured and the other NPUSCH may be transmitted fully. For example, the dropped or punctured NPUSCH may be the first one always, the second one always, or based on NPDCCH energy metric.

Collision handling for interlaced UL and DL grants

[00120] In the case of NPUSCH to NPDSCH collision, in one aspect, treat it as incorrect grant and drop either NPUSCH or NPDSCH (for example, the first, or the second, or based on the NPDCCH energy metrics etc.). In another aspect, treat it as valid

grants but only one of them is retained in colliding SFs by prioritizing one channel over the other. For example, one of the NPUSCH or NPDSCH may be dropped or punctured. For example, the dropped or punctured channel may be the first one always, the second one always, or based on NPDCCH energy metrics.

[00121] In the case of NPUSCH to HARQ-ACK collision, in one aspect, only one of them is retained in colliding SFs by prioritizing one channel over the other (e.g., HARQ-ACK prioritized over NPUSCH). In another aspect, HARQ-ACK may be multiplexed on NPUSCH (e.g., HARQ-ACK is used to modulate the DMRS of NPUSCH in colliding SFs).

[00122] As used herein, the term “identifying” encompasses a wide variety of actions. For example, “identifying” may include calculating, computing, processing, deriving, investigating, looking up (e.g., looking up in a table, a database or another data structure), ascertaining and the like. Also, “identifying” may include receiving (e.g., receiving information), accessing (e.g., accessing data in a memory) and the like. Also, “identifying” may include resolving, selecting, choosing, establishing and the like.

[00123] Moreover, the term “or” is intended to mean an inclusive “or” rather than an exclusive “or.” That is, unless specified otherwise, or clear from the context, the phrase, for example, “X employs A or B” is intended to mean any of the natural inclusive permutations. That is, for example the phrase “X employs A or B” is satisfied by any of the following instances: X employs A; X employs B; or X employs both A and B. As used herein, reference to an element in the singular is not intended to mean “one and only one” unless specifically so stated, but rather “one or more.” For example, the articles “a” and “an” as used in this application and the appended claims should generally be construed to mean “one or more” unless specified otherwise or clear from the context to be directed to a singular form. Unless specifically stated otherwise, the term “some” refers to one or more. A phrase referring to “at least one of” a list of items refers to any combination of those items, including single members. As an example, “at least one of: *a, b, or c*” is intended to cover: *a, b, c, a-b, a-c, b-c, and a-b-c*, as well as any combination with multiples of the same element (e.g., *a-a, a-a-a, a-a-b, a-a-c, a-b-b, a-c-c, b-b, b-b-b, b-b-c, c-c, and c-c-c* or any other ordering of *a, b, and c*). As used herein, including in the claims, the term “and/or,” when used in a list of two or more items, means that any one of the listed items can be employed by itself, or any combination of two or more of the

listed items can be employed. For example, if a composition is described as containing components A, B, and/or C, the composition can contain A alone; B alone; C alone; A and B in combination; A and C in combination; B and C in combination; or A, B, and C in combination.

[00124] In some cases, rather than actually communicating a frame, a device may have an interface to communicate a frame for transmission or reception. For example, a processor may output a frame, via a bus interface, to an RF front end for transmission. Similarly, rather than actually receiving a frame, a device may have an interface to obtain a frame received from another device. For example, a processor may obtain (or receive) a frame, via a bus interface, from an RF front end for transmission.

[00125] The methods disclosed herein comprise one or more steps or actions for achieving the described method. The method steps and/or actions may be interchanged with one another without departing from the scope of the claims. In other words, unless a specific order of steps or actions is specified, the order and/or use of specific steps and/or actions may be modified without departing from the scope of the claims.

[00126] The various operations of methods described above may be performed by any suitable means capable of performing the corresponding functions. The means may include various hardware and/or software component(s) and/or module(s), including, but not limited to a circuit, an application specific integrated circuit (ASIC), or processor. Generally, where there are operations illustrated in Figures, those operations may be performed by any suitable corresponding counterpart means-plus-function components.

[00127] For example, means for monitoring, means for identifying, means for selecting, means for determining, means for performing, means for transmitting, means for receiving, means for sending, means for signaling, means for requesting, and/or means for deriving may include one or more processors, transmitters, receivers, antennas, and/or other elements of the user equipment 120 and/or the base station 110 illustrated in FIG. 2.

[00128] Those of skill in the art would understand that information and signals may be represented using any of a variety of different technologies and techniques. For example, data, instructions, commands, information, signals, bits, symbols, and chips that may be

referenced throughout the above description may be represented by voltages, currents, electromagnetic waves, magnetic fields or particles, optical fields or particles, or combinations thereof.

[00129] Those of skill would further appreciate that the various illustrative logical blocks, modules, circuits, and algorithm steps described in connection with the disclosure herein may be implemented as hardware, software, or combinations thereof. To clearly illustrate this interchangeability of hardware and software, various illustrative components, blocks, modules, circuits, and steps have been described above generally in terms of their functionality. Whether such functionality is implemented as hardware or software depends upon the particular application and design constraints imposed on the overall system. Skilled artisans may implement the described functionality in varying ways for each particular application, but such implementation decisions should not be interpreted as causing a departure from the scope of the present disclosure.

[00130] The various illustrative logical blocks, modules, and circuits described in connection with the disclosure herein may be implemented or performed with a general-purpose processor, a digital signal processor (DSP), an application specific integrated circuit (ASIC), a field programmable gate array (FPGA) or other programmable logic device, discrete gate or transistor logic, discrete hardware components, or any combination thereof designed to perform the functions described herein. One or more aforementioned devices or processors may execute software. Software shall be construed broadly to mean instructions, instruction sets, code, code segments, program code, programs, subprograms, software modules, applications, software applications, software packages, routines, subroutines, objects, executables, threads of execution, procedures, functions, etc., whether referred to as software, firmware, middleware, microcode, hardware description language, or otherwise. A general-purpose processor may be a microprocessor, but in the alternative, the processor may be any conventional processor, controller, microcontroller, or state machine. A processor may also be implemented as a combination of computing devices, e.g., a combination of a DSP and a microprocessor, a plurality of microprocessors, one or more microprocessors in conjunction with a DSP core, or any other such configuration.

[00131] The steps of a method or algorithm described in connection with the disclosure herein may be embodied directly in hardware, in a software module executed by a

processor, or in a combination thereof. A software module may reside in RAM memory, flash memory, ROM memory, EPROM memory, EEPROM memory, phase change memory, registers, hard disk, a removable disk, a CD-ROM, or any other form of storage medium known in the art. An exemplary storage medium is coupled to the processor such that the processor can read information from, and write information to, the storage medium. In the alternative, the storage medium may be integral to the processor. The processor and the storage medium may reside in an ASIC. The ASIC may reside in a user terminal. In the alternative, the processor and the storage medium may reside as discrete components in a user terminal.

[00132] In one or more exemplary designs, the functions described may be implemented in hardware, software, or combinations thereof. If implemented in software, the functions may be stored on or transmitted over as one or more instructions or code on a computer-readable medium. Computer-readable media includes both computer storage media and communication media including any medium that facilitates transfer of a computer program from one place to another. A storage media may be any available media that can be accessed by a general purpose or special purpose computer. By way of example, and not limitation, such computer-readable media can comprise RAM, ROM, EEPROM, CD/DVD or other optical disk storage, magnetic disk storage or other magnetic storage devices, or any other medium that can be used to carry or store desired program code means in the form of instructions or data structures and that can be accessed by a general-purpose or special-purpose computer, or a general-purpose or special-purpose processor. Also, any connection is properly termed a computer-readable medium. For example, if the software is transmitted from a website, server, or other remote source using a coaxial cable, fiber optic cable, twisted pair, digital subscriber line (DSL), or wireless technologies such as infrared, radio, and microwave, then the coaxial cable, fiber optic cable, twisted pair, DSL, or wireless technologies such as infrared, radio, and microwave are included in the definition of medium. Disk and disc, as used herein, includes compact disc (CD), laser disc, optical disc, digital versatile disc (DVD), floppy disk and Blu-ray® disc where disks usually reproduce data magnetically, while discs reproduce data optically with lasers. Combinations of the above should also be included within the scope of computer-readable media.

[00133] The previous description of the disclosure is provided to enable any person

skilled in the art to make or use the disclosure. Various modifications to the disclosure will be readily apparent to those skilled in the art, and the generic principles defined herein may be applied to other variations without departing from the spirit or scope of the disclosure. Thus, the disclosure is not intended to be limited to the examples and designs described herein but is to be accorded the widest scope consistent with the principles and novel features disclosed herein.

WHAT IS CLAIMED IS:

CLAIMS

1. A method for wireless communication by a user equipment (UE), comprising:
 - monitoring a control channel in a narrowband of a system bandwidth for an uplink (UL) or a downlink (DL) grant;
 - receiving interlaced UL and DL grants; and
 - sending or receiving information in response to the received interlaced UL and DL grants.
2. The method of claim 1, wherein receiving the interlaced UL and DL grants comprise at least one of: receiving a DL grant as the next grant after an UL grant, or receiving an UL grant as the next grant after a DL grant.
3. The method of claim 1, wherein the interlaced UL and DL grants are received before start of the sending or receiving information in response to the interlaced UL and DL grants.
4. The method of claim 1, wherein the UE monitors control channel search space and receives a DL grant as the next grant after the UL grant and after start of the sending information on an uplink data channel in response to the UL grant.
5. The method of claim 4, wherein the uplink data channel is on a different carrier as the control channel search space.
6. The method of claim 4, wherein a subframe after a subframe in which the UE sends information on the UL data channel and before a subframe for DL communication serves as a guard subframe.
7. The method of claim 6, wherein a communication associated with the guard subframe is postponed to a next available subframe.
8. The method of claim 1, wherein each of the interlaced UL and DL grants support one or more hybrid automatic repeat request (HARQ) processes.

9. The method of claim 8, wherein each of the interlaced UL and DL grants supports two HARQ processes.
10. The method of claim 8, wherein the UE indicates, via capability signaling, support of at least one of:
two HARQ processes for each UL or DL grant, or interlacing of UL and DL grants.
11. The method of claim 1, further comprising:
in response to the sending or receiving information in response to the received interlaced UL and DL grants, identifying a collision, the collision comprising at least one of:
a collision between UL data channel and DL data channel, or
a collision between UL data channel and a hybrid ARQ acknowledgement (HARQ-ACK) signaling.
12. The method of claim 11, wherein the HARQ-ACK signaling comprises acknowledgement or non-acknowledgment (NACK) and wherein the HARQ-ACK signaling is for the DL data channel.
13. The method of claim 11, wherein the collision comprises the collision between the UL data channel and the DL data channel, further comprising at least one of:
determining to use one of the UL data channel and the DL data channel, or
for subframes that collide between the UL data channel and the DL data channel, determining to use the subframes of one of the UL data channel and the DL data channel.
14. The method of claim 13, wherein the determining to use is based, at least in part, on an energy metric threshold.
15. The method of claim 12, wherein the collision comprises the collision between the UL data channel and the HARQ-ACK signaling, further comprising at least one of:
for subframes that collide between the UL data channel and the HARQ-ACK signaling, determining to transmit the HARQ-ACK signaling, or multiplexing the HARQ-ACK signaling with the UL data channel.

16. The method of claim 15, wherein the multiplexing the HARQ-ACK signaling with the UL data channel comprises modulating demodulation reference signal (DMRS) of the UL data channel with the HARQ-ACK signaling for subframes that collide between the UL data channel and the HARQ-ACK signaling.

17. The method of claim 1, wherein the UE is configured for narrowband Internet-of-things (NB-IoT).

18. The method of claim 1, wherein the UE is configured for time division duplex (TDD) operation.

19. The method of claim 1, wherein the UE is configured for frequency division duplex (FDD) operation.

20. The method of claim 1, wherein the control channel comprises a narrowband physical downlink control channel (NPDCCH).

21. The method of claim 1, wherein the sending information comprises sending information in an uplink data channel in response to the received UL grant; and wherein the receiving information comprises receiving information in a downlink data channel in response to the DL grant.

22. The method of claim 1, wherein the uplink data channel comprises a narrowband physical uplink shared channel (NPUSCH), and wherein the downlink data channel comprises a narrowband physical downlink shared channel (NPDSCH).

23. The method of claim 11, wherein the DL data channel comprises a narrowband physical downlink shared channel (NPDSCH), the HARQ-ACK comprises a hybrid automatic repeat request (HARQ) acknowledgement or non-acknowledgement, and the UL data channel comprises a narrowband physical uplink shared channel (NPUSCH).

24. A method for wireless communication by a user equipment (UE), comprising:
monitoring a control channel in a narrowband of a system bandwidth for an uplink (UL) or a downlink (DL) grant;
receiving two consecutive UL or DL grants, wherein the consecutive UL or DL grants have a same HARQ process identification (ID); and
selecting one of the grants to use, based, at least in part, on at least one of:
the grant meeting an energy metric threshold,
the grant being received first, or
the grant being received second,
or selecting both grants to use, wherein the grants are treated as hybrid automatic repeat request (HARQ) retransmissions.
25. The method of claim 24, wherein receiving two consecutive UL or DL grants comprise at least one of:
receiving a UL grant as the next grant after a UL grant; or
receiving a DL grant as the next grant after a DL grant.
26. The method of claim 24, wherein the UE is configured for narrowband Internet-of-things (NB-IoT).
27. The method of claim 24, wherein the control channel comprises a narrowband physical downlink control channel (NPDCCH).
28. A method for wireless communication by a user equipment (UE), comprising:
monitoring a control channel in a narrowband of a system bandwidth for an uplink (UL) or a downlink (DL) grant;
receiving two consecutive UL or DL grants;
sending or receiving information in response to the received two consecutive UL and DL grants; and
in response to the sending or receiving information, identifying a collision, the collision comprising at least one of:
collision between first DL data channel and second DL data channel,
collision between the second DL data channel and first HARQ

acknowledgement (HARQ-ACK) signaling for the first DL data channel,
collision between first HARQ-ACK signaling for the first DL data channel
and second HARQ-ACK signaling for the second DL data channel, or
collision between first UL data channel and second UL data channel.

29. The method of claim 28, wherein receiving two consecutive UL or DL grants
comprise at least one of:

- receiving a UL grant as the next grant after a UL grant; or
- receiving a DL grant as the next grant after a DL grant.

30. The method of claim 28, wherein the collision comprises the collision between
the first DL data channel and the second DL data channel, the method further comprising
at least one of:

- selecting only one of the first or second DL data channel to monitor; or
- for subframes that collides between the first DL data channel and the second DL data
channel, selecting only one of the first or second DL data channel to monitor.

31. The method of claim 30, wherein the selecting comprises:

- selecting the first DL data channel signaling;
- selecting the second DL data channel signaling; or
- selecting the first or second DL data channel signaling based, at least in
part, on an energy metric threshold.

32. The method of claim 28, wherein the collision comprises the collision between
the second DL data channel and the first HARQ-ACK signaling for the first DL data
channel, the method further comprising at least one of: determining to not use the first
HARQ-ACK signaling; or determining to not use the second DL data channel.

33. The method of claim 32, wherein the determining to not use the first HARQ-ACK
signaling comprises determining to not use all subframes for the first HARQ-ACK
signaling or only subframes for the first HARQ-ACK signaling that collide with the
second data channel.

34. The method of claim 32, wherein the determining to not use the second DL data channel comprises determining to not use all subframes for the second DL shared or only subframes for the second DL that collide with the first HARQ-ACK signaling.

35. The method of claim 28, wherein colliding subframes comprise at least one of: subframes for ACK, subframes for DL data channel, or guard subframes.

36. The method of claim 28, wherein the collision comprises the collision between the first HARQ-ACK signaling for the first DL data channel and the second HARQ-ACK signaling for the second DL data channel, further comprising at least one of:

sending one of the first HARQ-ACK signaling or the second HARQ-ACK signaling, or

sending one of the first HARQ-ACK signaling or the second HARQ-ACK signaling and puncturing the other one of the first HARQ-ACK signaling or the second HARQ-ACK signaling.

37. The method of claim 36, wherein only one of the first DL data channel and the second DL data channel is decoded successfully, further comprising sending HARQ-ACK for the one of the first DL data channel and the second DL data channel that is decoded successfully and puncturing the HARQ-ACK for the other one of the first DL data channel signaling and the second DL data channel signaling.

38. The method of claim 28, wherein the collision comprises the collision between the first UL data channel and the second UL data channel, further comprising at least one of:

determining to transmit one of the first UL data channel and the second UL data channel, or

determining to transmit one of the first UL data channel and the second UL data channel and puncturing the other one of first UL data channel and the second UL data channel.

39. The method of claim 38, wherein the determining to transmit or the puncturing are based, at least in part, on an energy metric threshold.

40. The method of claim 28, wherein the DL data channel comprises a narrowband physical downlink shared channel (NPDSCH), the HARQ-ACK comprises a hybrid automatic repeat request (HARQ) acknowledgement or non-acknowledgement, and the UL data channel comprises a narrowband physical uplink shared channel (NPUSCH).

41. The method of claim 28, wherein the UE is configured for narrowband Internet-of-Things (NB-IoT).

42. The method of claim 28, wherein the control channel comprises a narrowband physical downlink control channel (NPDCCH), the first DL data channel and the second DL data channel comprise a NPDSCH, and the first UL data channel and the second UL data channel comprise a NPUSCH.

43. A method for wireless communication by a base station (BS), comprising:
transmitting interlaced uplink (UL) and downlink (DL) grants on a control channel in a narrowband of a system bandwidth to a user equipment (UE); and
receiving information from or sending information to the UE in response to the transmitted interlaced UL and DL grants.

44. A method for wireless communication by a base station (BS), comprising:
transmitting, to a user equipment (UE), two consecutive uplink (UL) or downlink (DL) grants on a control channel in a narrowband of a system bandwidth, the consecutive UL or DL grants having a same HARQ process identification (ID), wherein:
one of the grants is selected for use by the UE, based, at least in part, on at least one of:

- the grant meeting an energy metric threshold,
- the grant being received first, or
- the grant being received second,

or both grants are selected for use by the UE, wherein the grants are treated as hybrid automatic repeat request (HARQ) retransmissions.

45. A method for wireless communication by a base station (BS), comprising:

transmitting, to a user equipment (UE), two consecutive UL or DL grants on a control channel in a narrowband of a system bandwidth;

sending or receiving information in response to the transmitted two consecutive UL and DL grants; and

in response to the sending or receiving information, identifying a collision comprising at least one of:

- collision between first DL data channel and second DL data channel,
- collision between the second DL data channel and first HARQ acknowledgement (HARQ-ACK) signaling for the first DL data channel,
- collision between first HARQ-ACK signaling for the first DL data channel and second HARQ-ACK signaling for the second DL data channel, or
- collision between first UL data channel and second UL data channel.

46. An apparatus for wireless communication by a user equipment (UE), comprising:
 means for monitoring a control channel in a narrowband of a system bandwidth for an uplink (UL) or a downlink (DL) grant;
 means for receiving interlaced UL and DL grants; and
 means for sending or receiving information in response to the received interlaced UL and DL grants.

47. An apparatus for wireless communication by a user equipment (UE), comprising:
 means for monitoring a control channel in a narrowband of a system bandwidth for an uplink (UL) or a downlink (DL) grant;
 means for receiving two consecutive UL or DL grants, wherein the consecutive UL or DL grants have a same HARQ process identification (ID); and
 means for:
 selecting one of the grants to use, based, at least in part, on at least one of:
 the grant meeting an energy metric threshold,
 the grant being received first, or
 the grant being received second,
 or selecting both grants to use, wherein the grants are treated as hybrid automatic repeat request (HARQ) retransmissions.

48. An apparatus for wireless communication by a user equipment (UE), comprising:
means for monitoring a control channel in a narrowband of a system bandwidth for an uplink (UL) or a downlink (DL) grant;
means for receiving two consecutive UL or DL grants;
means for sending or receiving information in response to the received two consecutive UL and DL grants; and
means for, in response to the sending or receiving information, identifying a collision, the collision comprising at least one of:
collision between first DL data channel and second DL data channel,
collision between the second DL data channel and first HARQ acknowledgement (HARQ-ACK) signaling for the first DL data channel,
collision between first HARQ-ACK signaling for the first DL data channel and second HARQ-ACK signaling for the second DL data channel, or
collision between first UL data channel and second UL data channel.
49. An apparatus for wireless communication by a base station (BS), comprising:
means for transmitting interlaced uplink (UL) and downlink (DL) grants on a control channel in a narrowband of a system bandwidth to a user equipment (UE); and
means for receiving information from or sending information to the UE in response to the transmitted interlaced UL and DL grants.
50. An apparatus for wireless communication by a base station (BS), comprising:
means for transmitting, to a user equipment (UE), two consecutive uplink (UL) or downlink (DL) grants on a control channel in a narrowband of a system bandwidth, the consecutive UL or DL grants having a same HARQ process identification (ID), wherein:
one of the grants is selected for use by the UE, based, at least in part, on at least one of:
the grant meeting an energy metric threshold,
the grant being received first, or
the grant being received second,
or both grants are selected for use by the UE, wherein the grants are treated as hybrid automatic repeat request (HARQ) retransmissions.

51. An apparatus for wireless communication by a base station (BS), comprising:
- means for transmitting, to a user equipment (UE), two consecutive UL or DL grants on a control channel in a narrowband of a system bandwidth;
 - means for sending or receiving information in response to the transmitted two consecutive UL and DL grants; and
 - means for, in response to the sending or receiving information, identifying a collision comprising at least one of:
 - collision between first DL data channel and second DL data channel,
 - collision between the second DL data channel and first HARQ acknowledgement (HARQ-ACK) signaling for the first DL data channel,
 - collision between first HARQ-ACK signaling for the first DL data channel and second HARQ-ACK signaling for the second DL data channel, or
 - collision between first UL data channel and second UL data channel.
52. An apparatus for wireless communication by a user equipment (UE), comprising one or more processors configured to:
- monitor a control channel in a narrowband of a system bandwidth for an uplink (UL) or a downlink (DL) grant,
 - receive interlaced UL and DL grants, and
 - send or receive information in response to the received interlaced UL and DL grants; and
- a memory coupled to the one or more processors.
53. An apparatus for wireless communication by a user equipment (UE), comprising one or more processors configured to:
- monitor a control channel in a narrowband of a system bandwidth for an uplink (UL) or a downlink (DL) grant,
 - receive two consecutive UL or DL grants, wherein the consecutive UL or DL grants have a same HARQ process identification (ID), and
 - select one of the grants to use based, at least in part, on at least one of:
 - the grant meeting an energy metric threshold,
 - the grant being received first, or
 - the grant being received second,

or select both grants to use, wherein the grants are treated as hybrid automatic repeat request (HARQ) retransmissions; and
a memory coupled to the one or more processors.

54. An apparatus for wireless communication by a user equipment (UE), comprising one or more processors configured to:

monitor a control channel in a narrowband of a system bandwidth for an uplink (UL) or a downlink (DL) grant,

receive two consecutive UL or DL grants,

send or receive information in response to the received two consecutive UL and DL grants, and

in response to the sending or receiving information, identify a collision, the collision comprising at least one of:

collision between first DL data channel and second DL data channel,

collision between the second DL data channel and first HARQ acknowledgement (HARQ-ACK) signaling for the first DL data channel,

collision between first HARQ-ACK signaling for the first DL data channel and second HARQ-ACK signaling for the second DL data channel, or

collision between first UL data channel and second UL data channel; and

a memory coupled to the one or more processors.

55. An apparatus for wireless communication by a base station (BS), comprising one or more processors configured to:

transmit interlaced uplink (UL) and downlink (DL) grants on a control channel in a narrowband of a system bandwidth to a user equipment (UE), and

receive information from or sending information to the UE in response to the transmitted interlaced UL and DL grants; and

a memory coupled to the one or more processors.

56. An apparatus for wireless communication by a base station (BS), comprising one or more processors configured to:

transmit, to a user equipment (UE), two consecutive uplink (UL) or downlink (DL) grants on a control channel in a narrowband of a system bandwidth, the consecutive

UL or DL grants having a same HARQ process identification (ID), wherein:
one of the grants is selected for use by the UE, based, at least in part, on at least one of:
the grant meeting an energy metric threshold,
the grant being received first, or
the grant being received second,
or both grants are selected for use by the UE, wherein the grants are treated as hybrid automatic repeat request (HARQ) retransmissions; and
a memory coupled to the one or more processors.

57. An apparatus for wireless communication by a base station (BS), comprising one or more processors configured to:

transmit, to a user equipment (UE), two consecutive UL or DL grants on a control channel in a narrowband of a system bandwidth,

send or receive information in response to the transmitted two consecutive UL and DL grants, and

in response to the sending or receiving information, identify a collision comprising at least one of:

collision between first DL data channel and second DL data channel,
collision between the second DL data channel and first HARQ acknowledgement (HARQ-ACK) signaling for the first DL data channel,

collision between first HARQ-ACK signaling for the first DL data channel and second HARQ-ACK signaling for the second DL data channel, or

collision between first UL data channel and second UL data channel; and
a memory coupled to the one or more processors.

58. A computer-readable medium having executable code stored thereon for wireless communication by a user equipment (UE), the executable code comprising:

code for monitoring a control channel in a narrowband of a system bandwidth for an uplink (UL) or a downlink (DL) grant;

code for receiving interlaced UL and DL grants; and

code for sending or receiving information in response to the received interlaced UL and DL grants.

59. A computer-readable medium having executable code stored thereon for wireless communication by a user equipment (UE), the executable code comprising:

- code for monitoring a control channel in a narrowband of a system bandwidth for an uplink (UL) or a downlink (DL) grant;

- code receiving two consecutive UL or DL grants, wherein the consecutive UL or DL grants have a same HARQ process identification (ID); and

- code for:

- selecting one of the grants to use based, at least in part, on at least one of:

- the grant meeting an energy metric threshold,

- the grant being received first, or

- the grant being received second,

- or selecting both grants to use, wherein the grants are treated as hybrid automatic repeat request (HARQ) retransmissions.

60. A computer-readable medium having executable code stored thereon for wireless communication by a user equipment (UE), the executable code comprising:

- code for monitoring a control channel in a narrowband of a system bandwidth for an uplink (UL) or a downlink (DL) grant;

- code for receiving two consecutive UL or DL grants;

- code for sending or receiving information in response to the received two consecutive UL and DL grants; and

- code for, in response to the sending or receiving information, identifying a collision, the collision comprising at least one of:

- collision between first DL data channel and second DL data channel,

- collision between the second DL data channel and first HARQ acknowledgement (HARQ-ACK) signaling for the first DL data channel,

- collision between first HARQ-ACK signaling for the first DL data channel and second HARQ-ACK signaling for the second DL data channel, or

- collision between first UL data channel and second UL data channel.

61. A computer-readable medium having executable code stored thereon for wireless communication by a base station (BS), the executable code comprising:

code for transmitting interlaced uplink (UL) and downlink (DL) grants on a control channel in a narrowband of a system bandwidth to a user equipment (UE); and
code for receiving information from or sending information to the UE in response to the transmitted interlaced UL and DL grants.

62. A computer-readable medium having executable code stored thereon for wireless communication by a base station (BS), the executable code comprising:

code for transmitting, to a user equipment (UE), two consecutive uplink (UL) or downlink (DL) grants on a control channel in a narrowband of a system bandwidth, the consecutive UL or DL grants having a same HARQ process identification (ID), wherein:

one of the grants is selected for use by the UE, based, at least in part, on at least one of:

- the grant meeting an energy metric threshold,
 - the grant being received first, or
 - the grant being received second,
- or both grants are selected for use by the UE, wherein the grants are treated as hybrid automatic repeat request (HARQ) retransmissions.

63. A computer-readable medium having executable code stored thereon for wireless communication by a base station (BS), the executable code comprising:

code for transmitting, to a user equipment (UE), two consecutive UL or DL grants on a control channel in a narrowband of a system bandwidth;

code for sending or receiving information in response to the transmitted two consecutive UL and DL grants; and

code for, in response to the sending or receiving information, identifying a collision comprising at least one of:

- collision between first DL data channel and second DL data channel,
- collision between the second DL data channel and first HARQ acknowledgement (HARQ-ACK) signaling for the first DL data channel,
- collision between first HARQ-ACK signaling for the first DL data channel and second HARQ-ACK signaling for the second DL data channel, or
- collision between first UL data channel and second UL data channel.

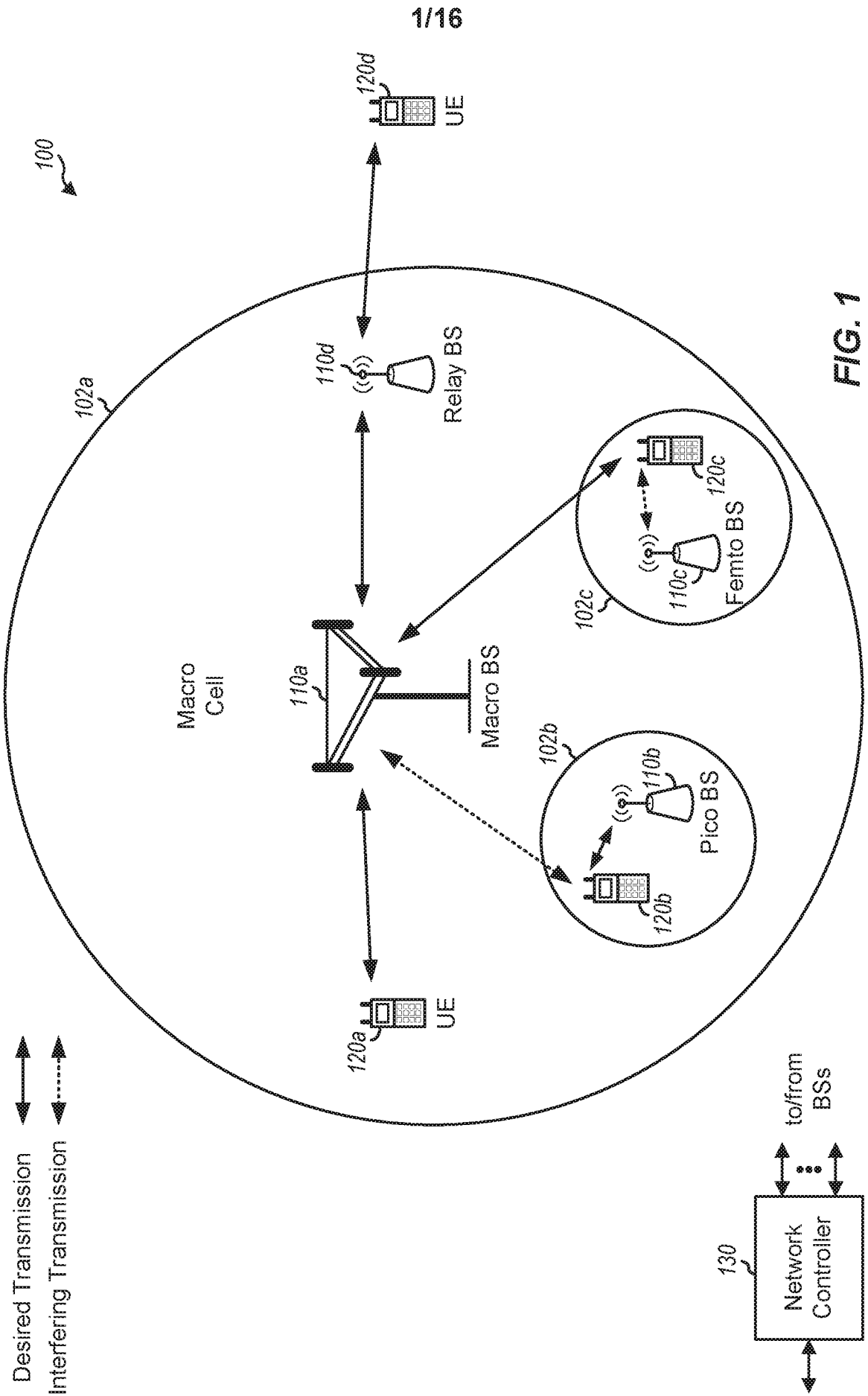

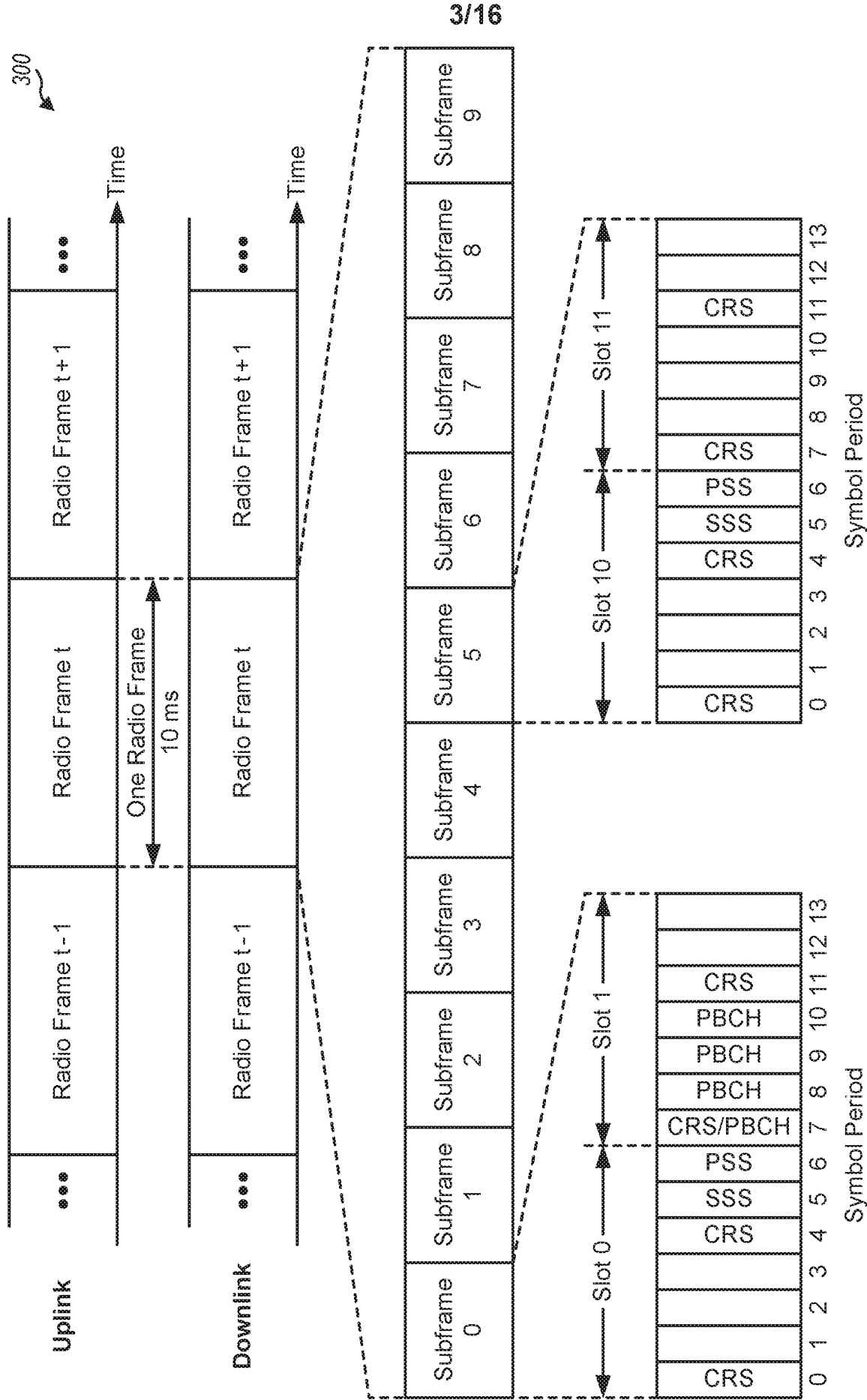

FIG. 3

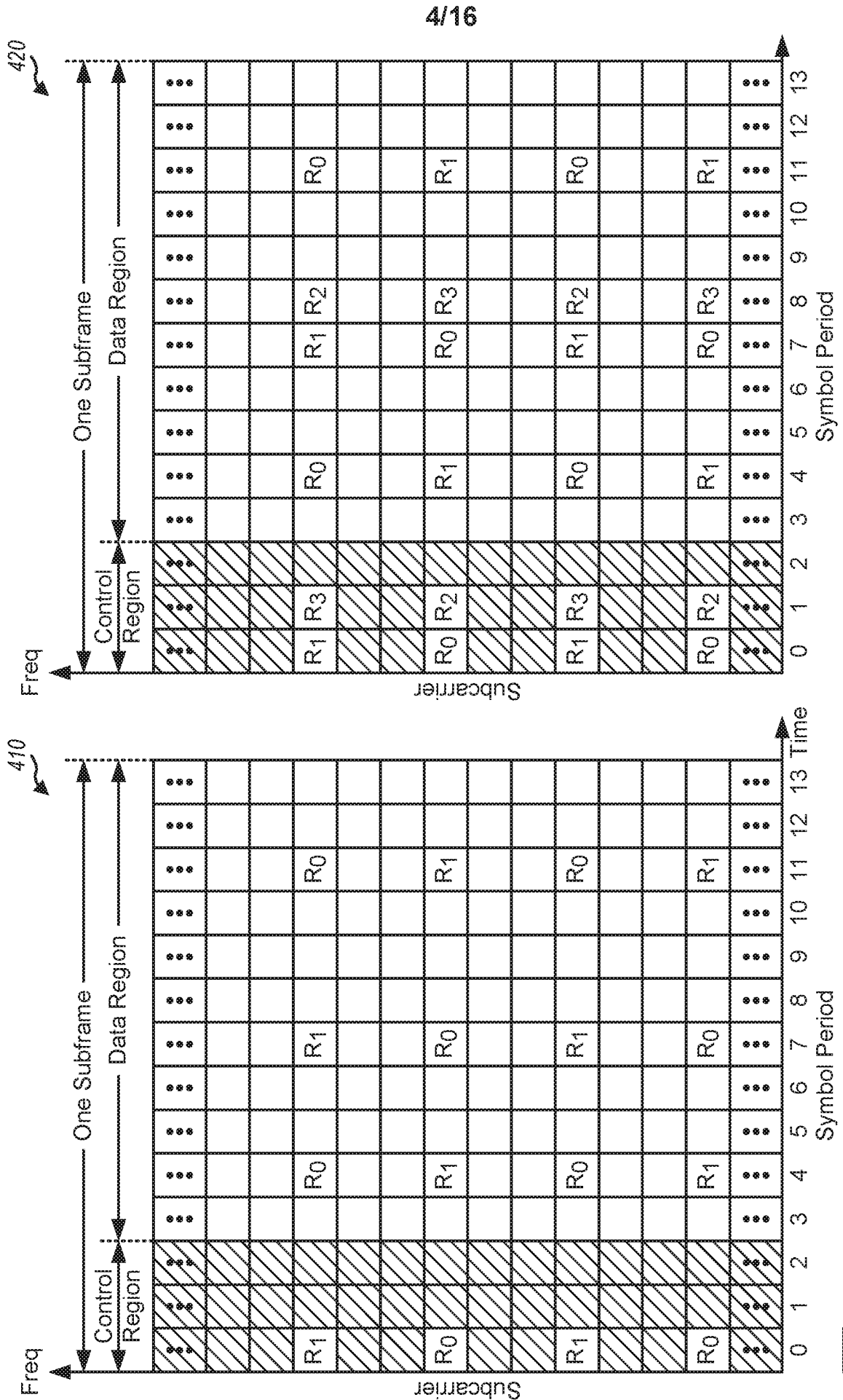

FIG. 4

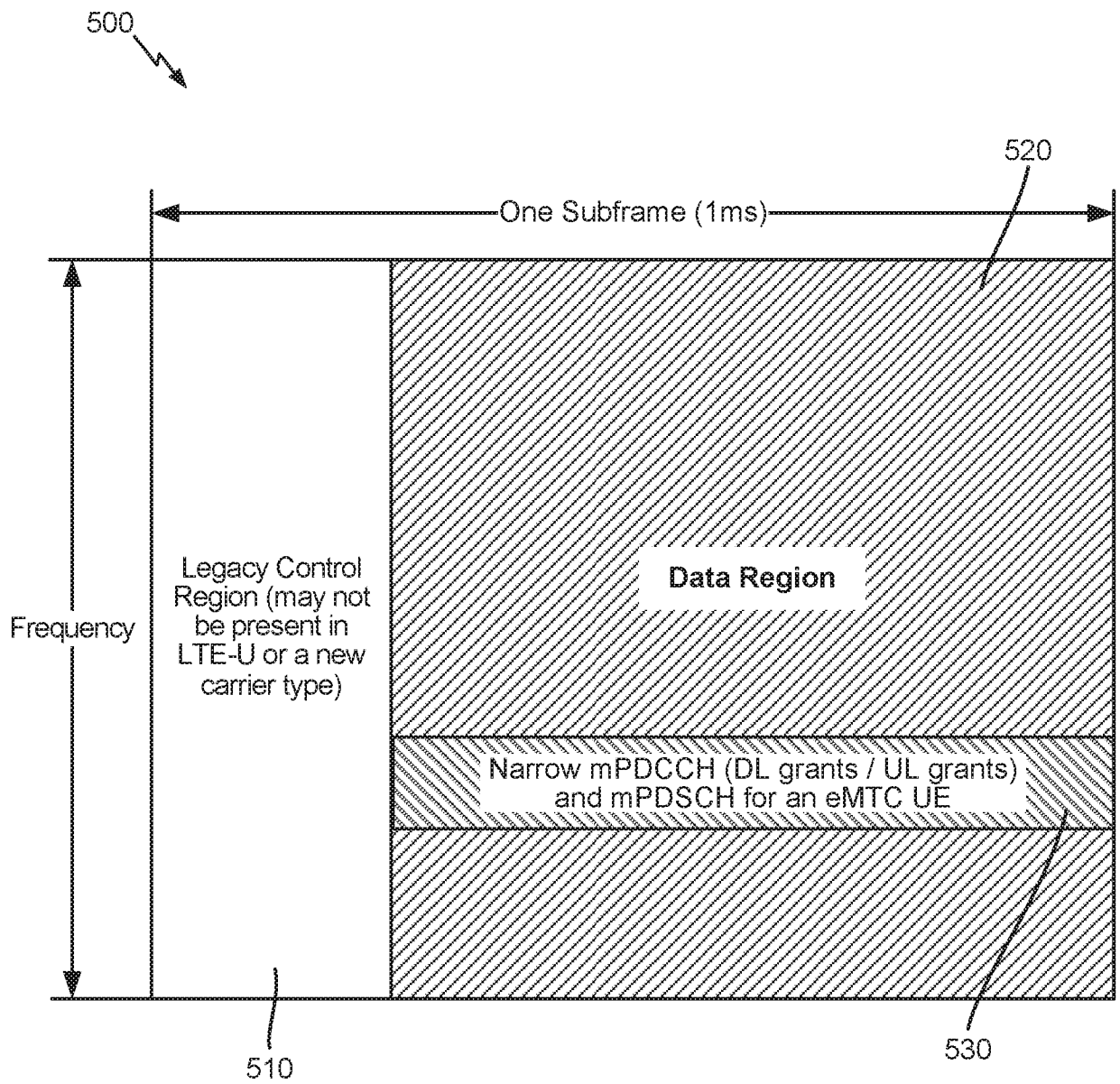

FIG. 5

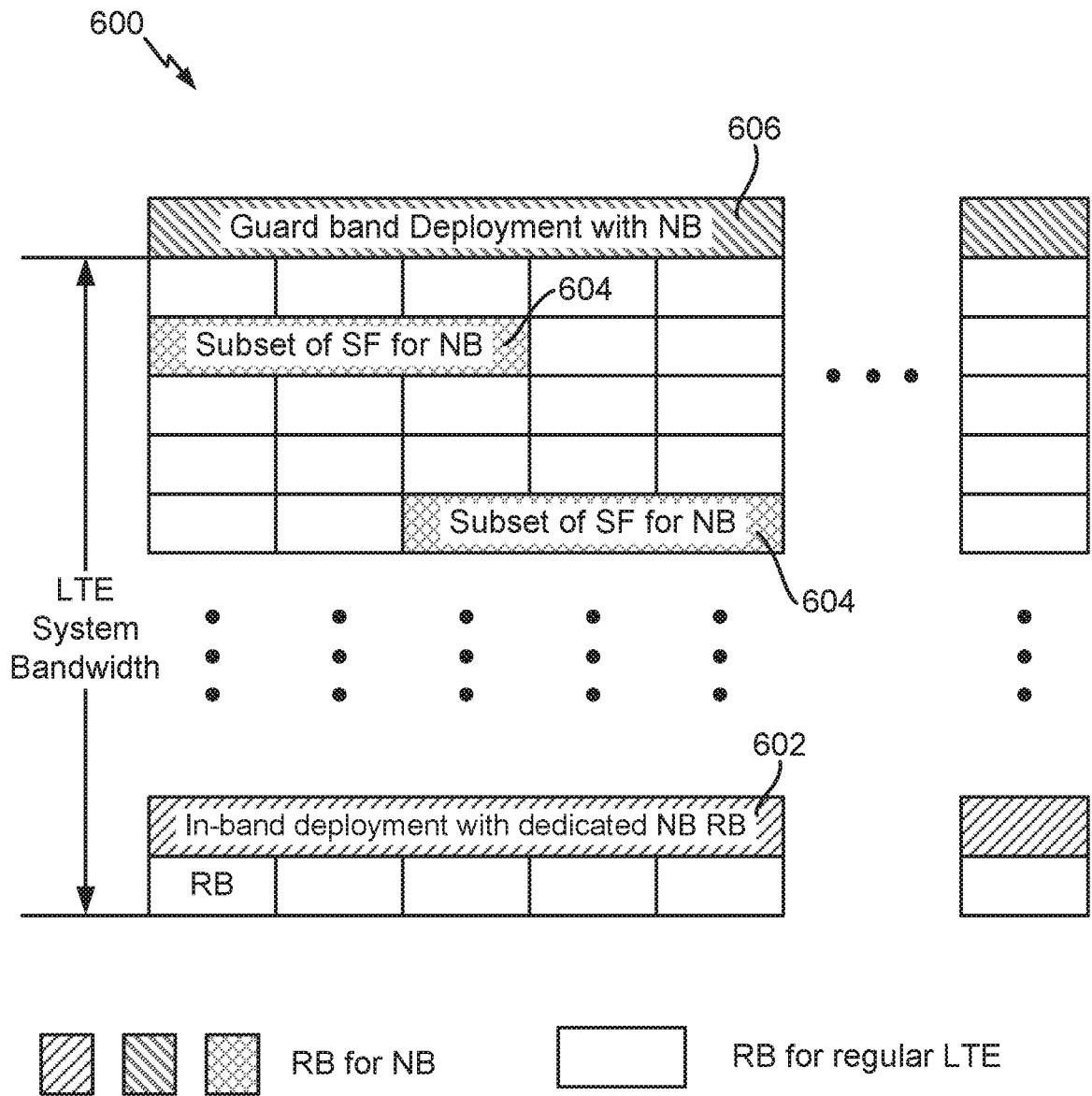

FIG. 6

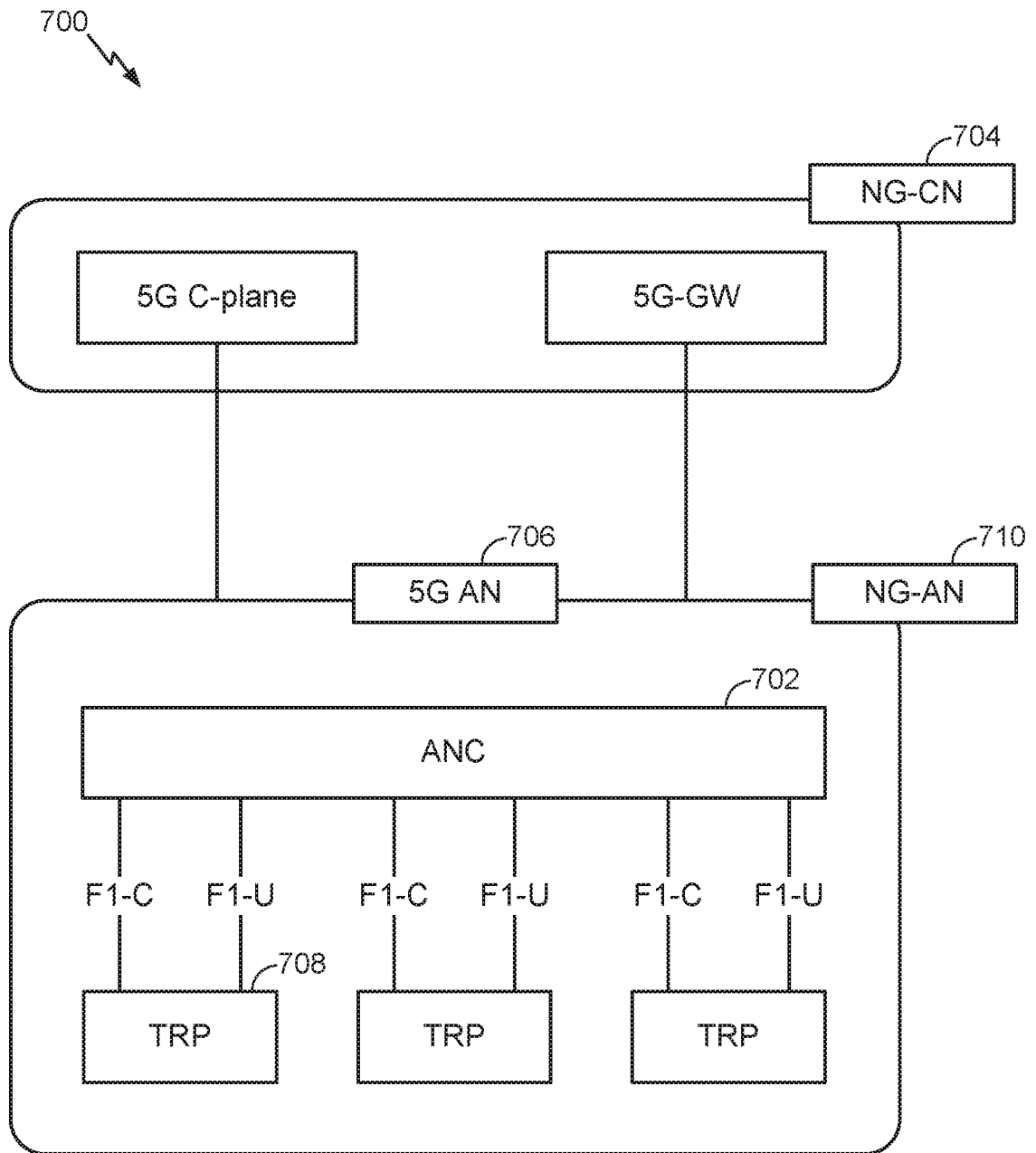

FIG. 7

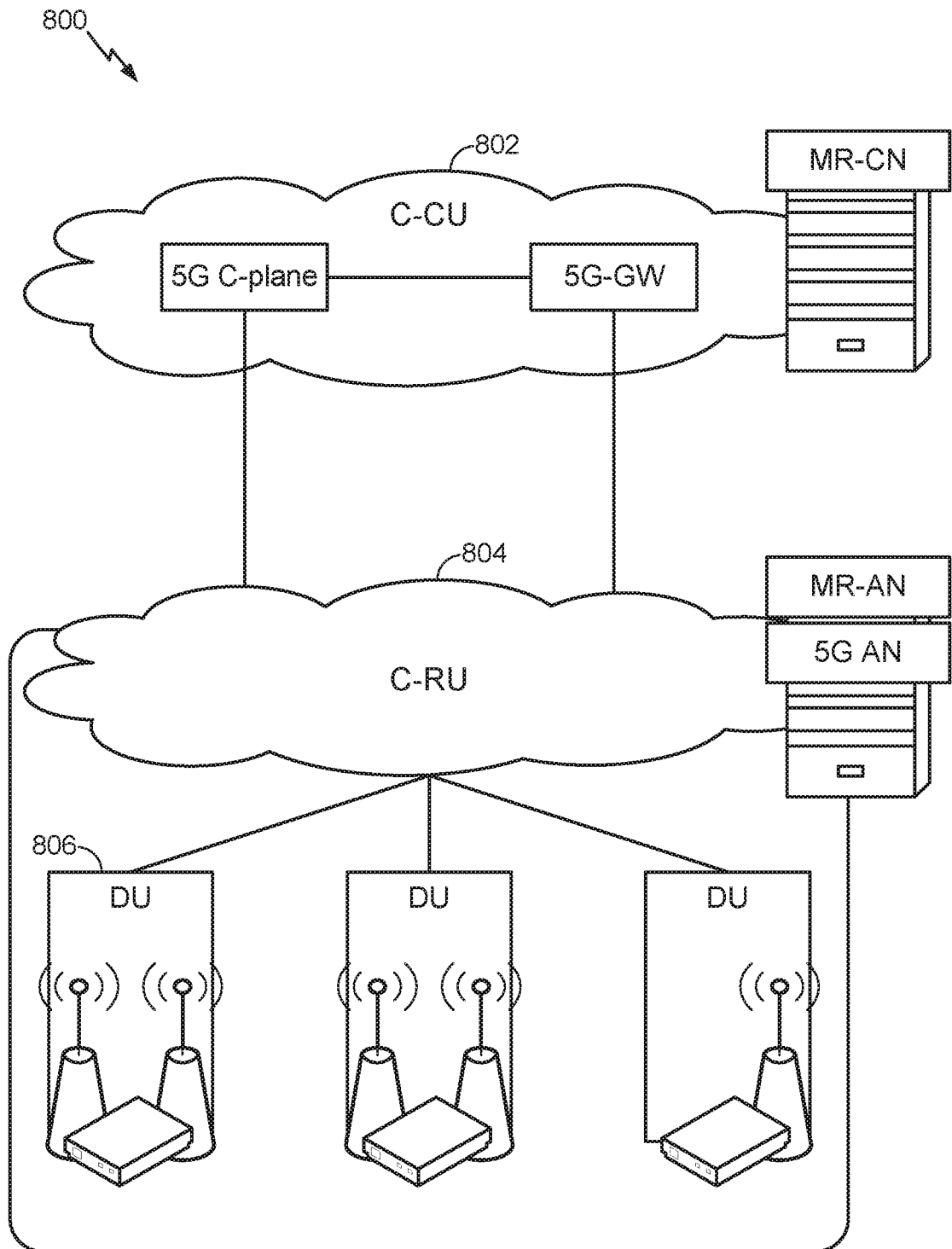

FIG. 8

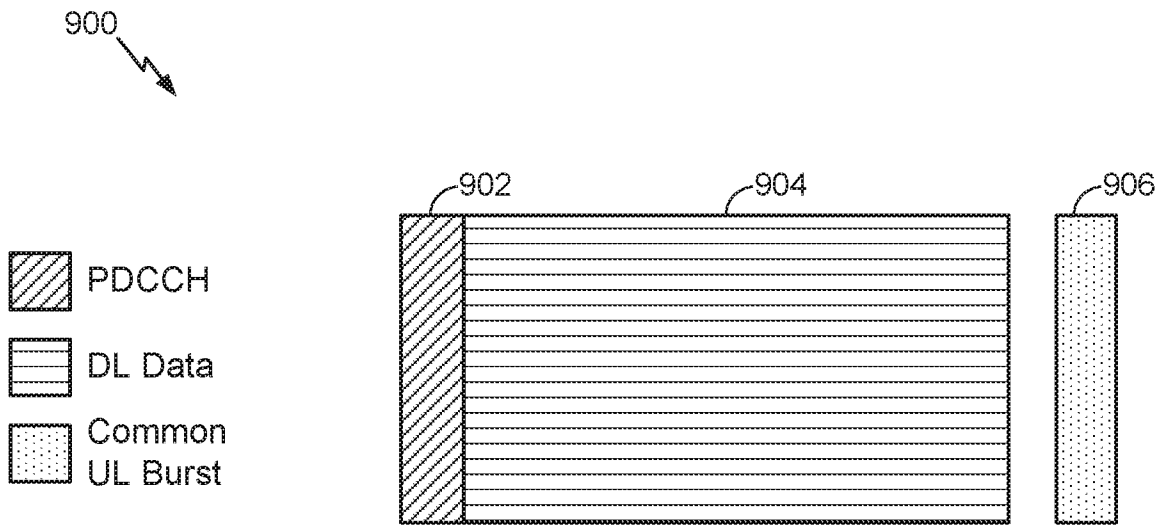

FIG. 9

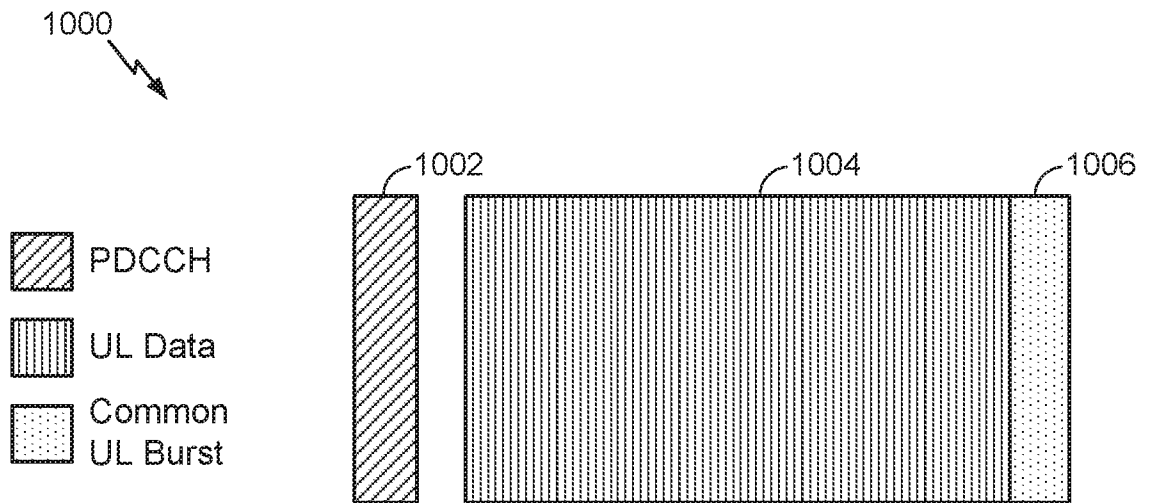

FIG. 10

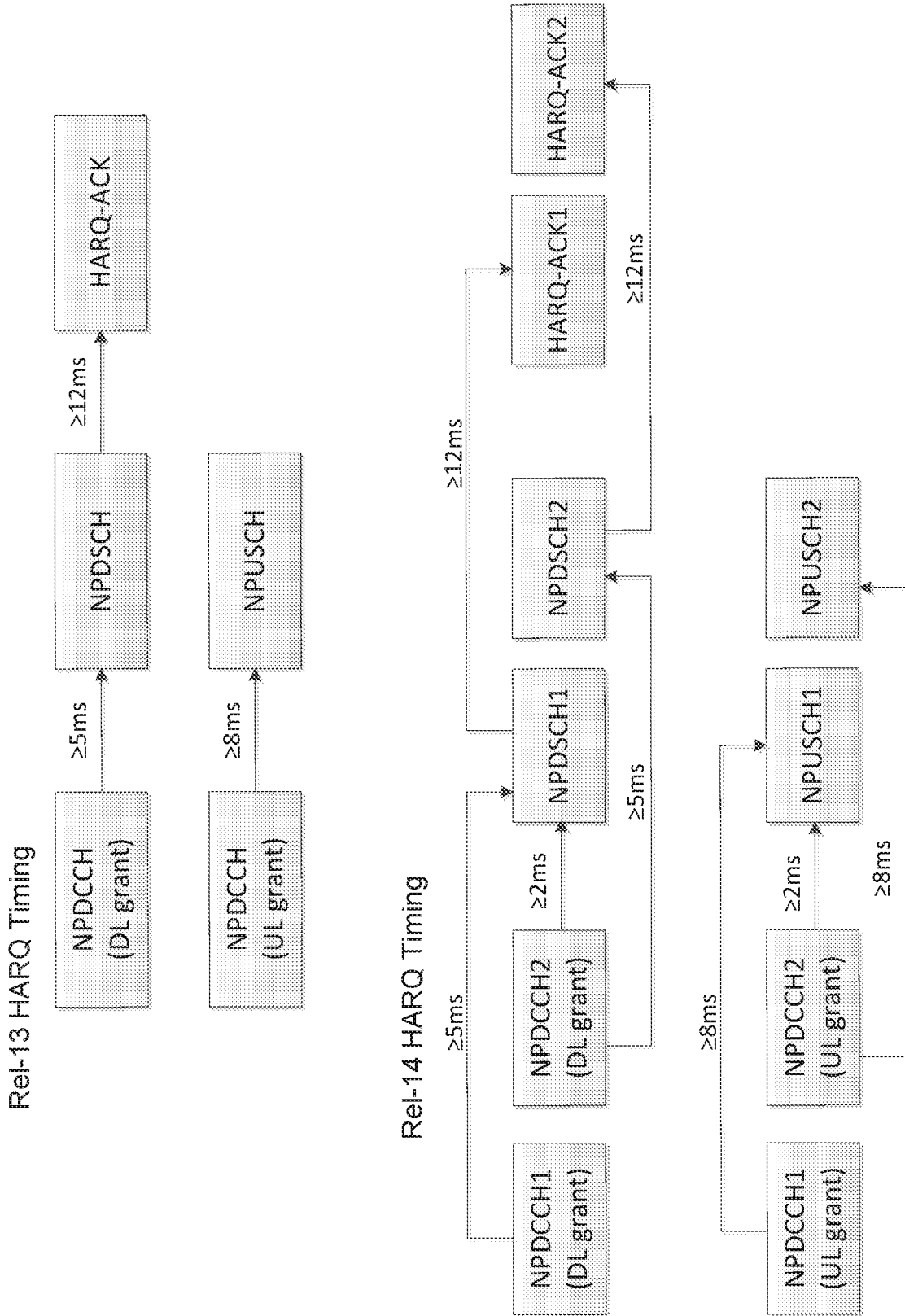

FIG. 11

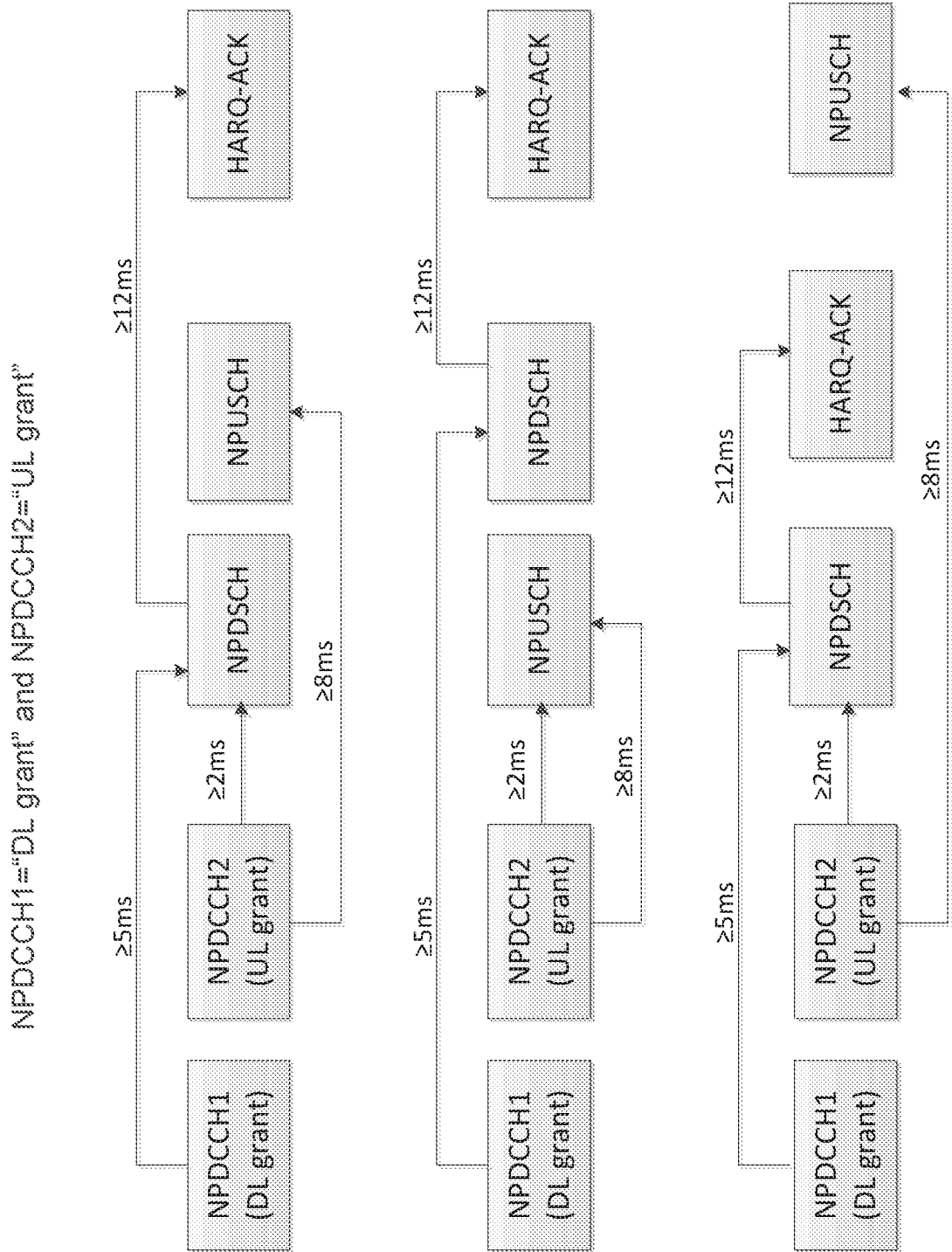

FIG. 12

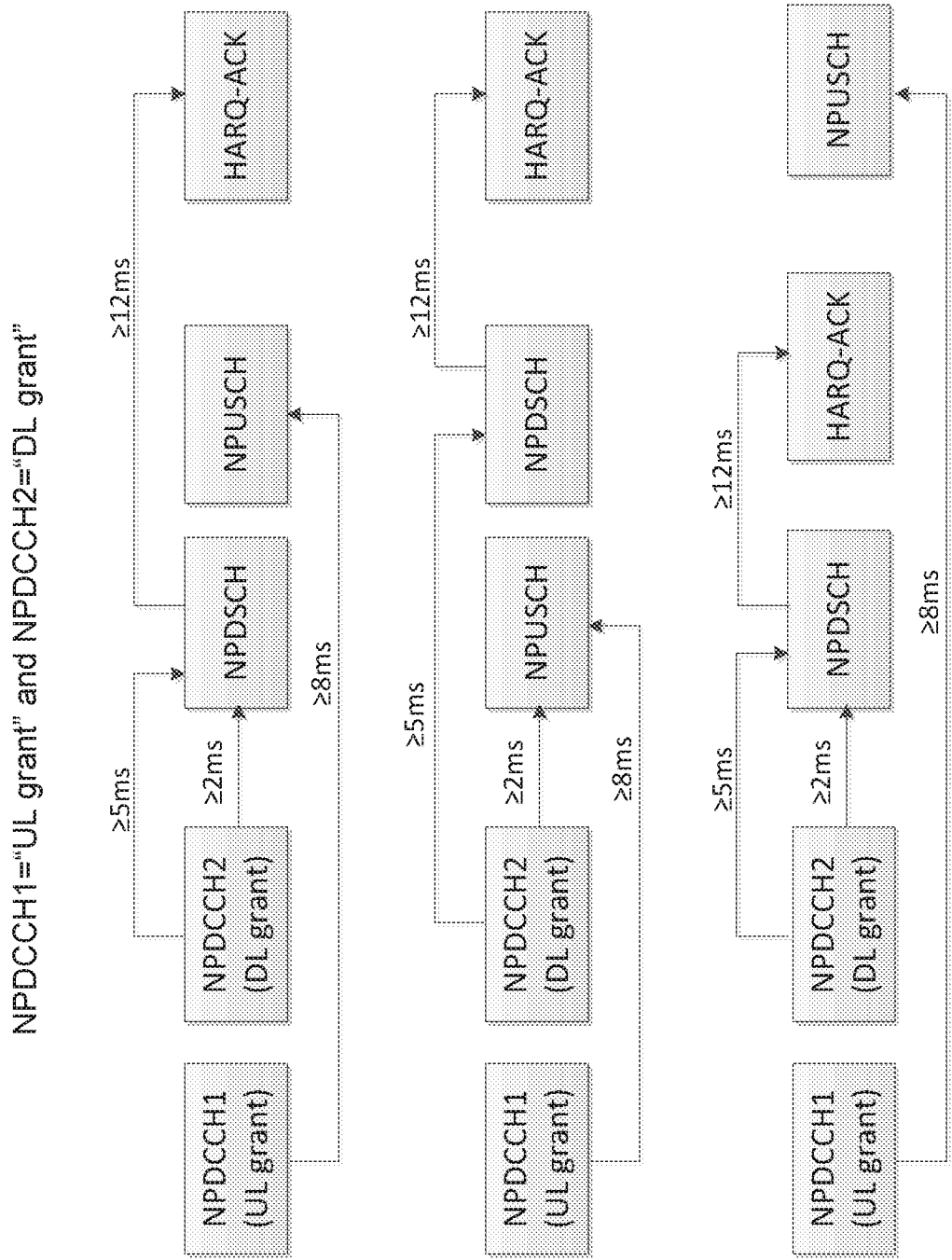

FIG. 13

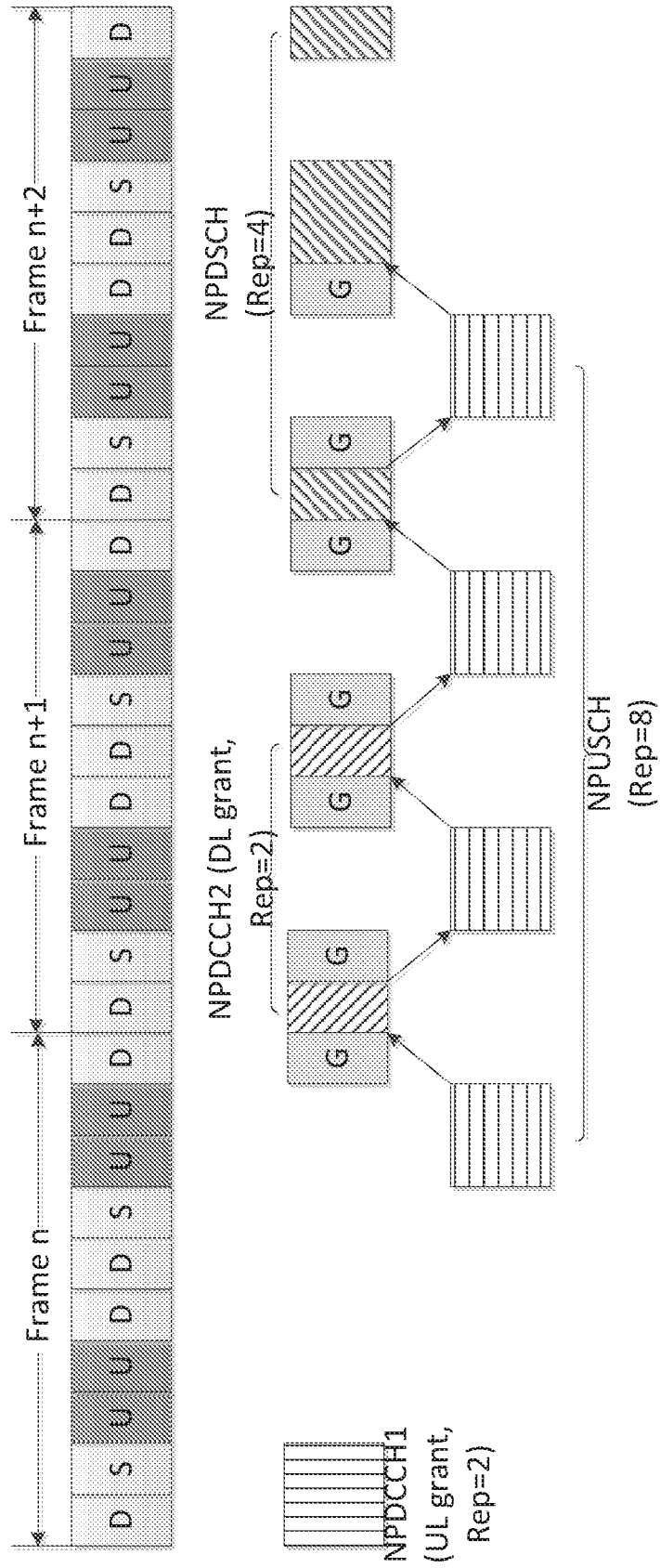

FIG. 14

14/16

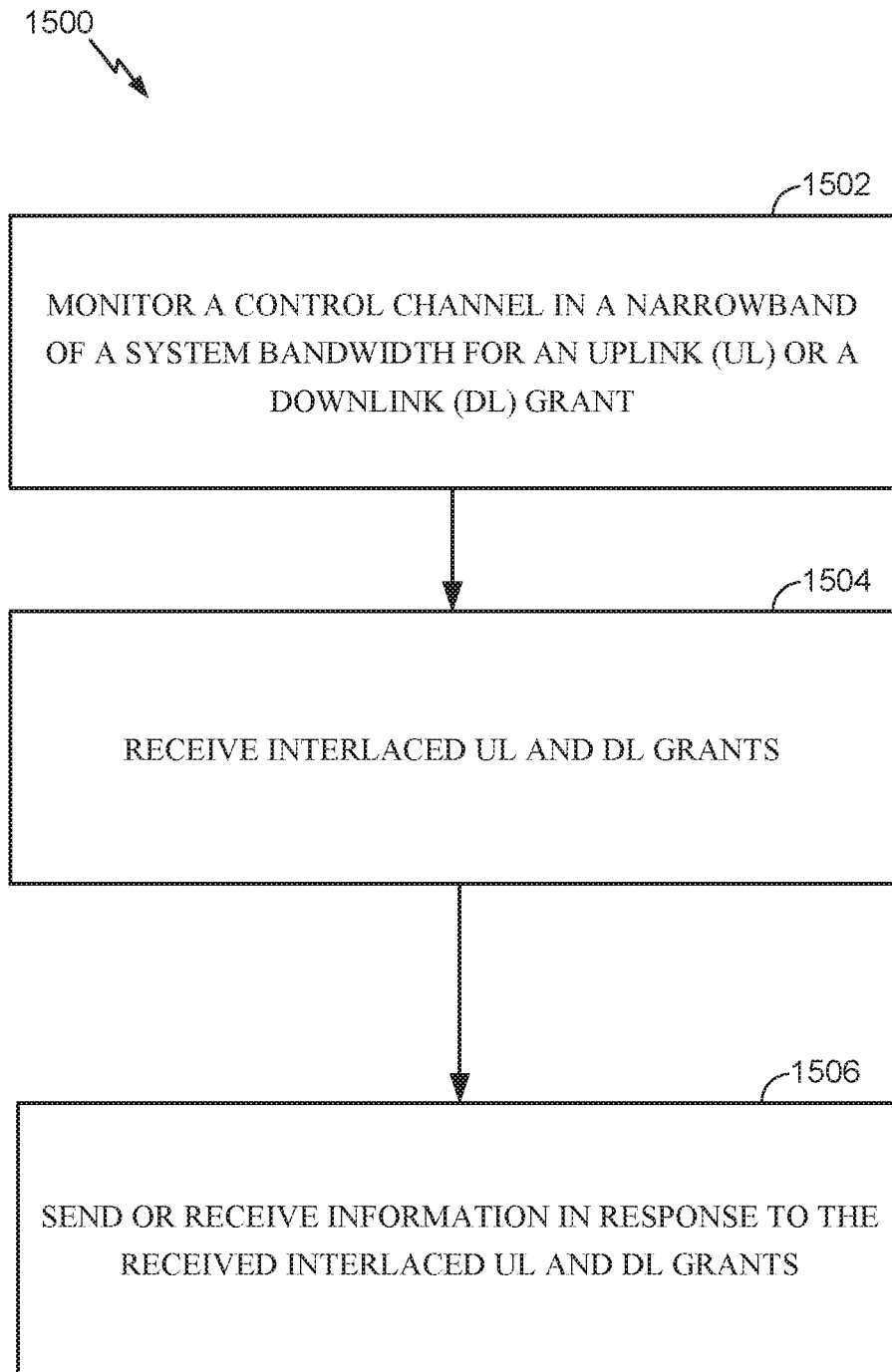

FIG. 15

15/16

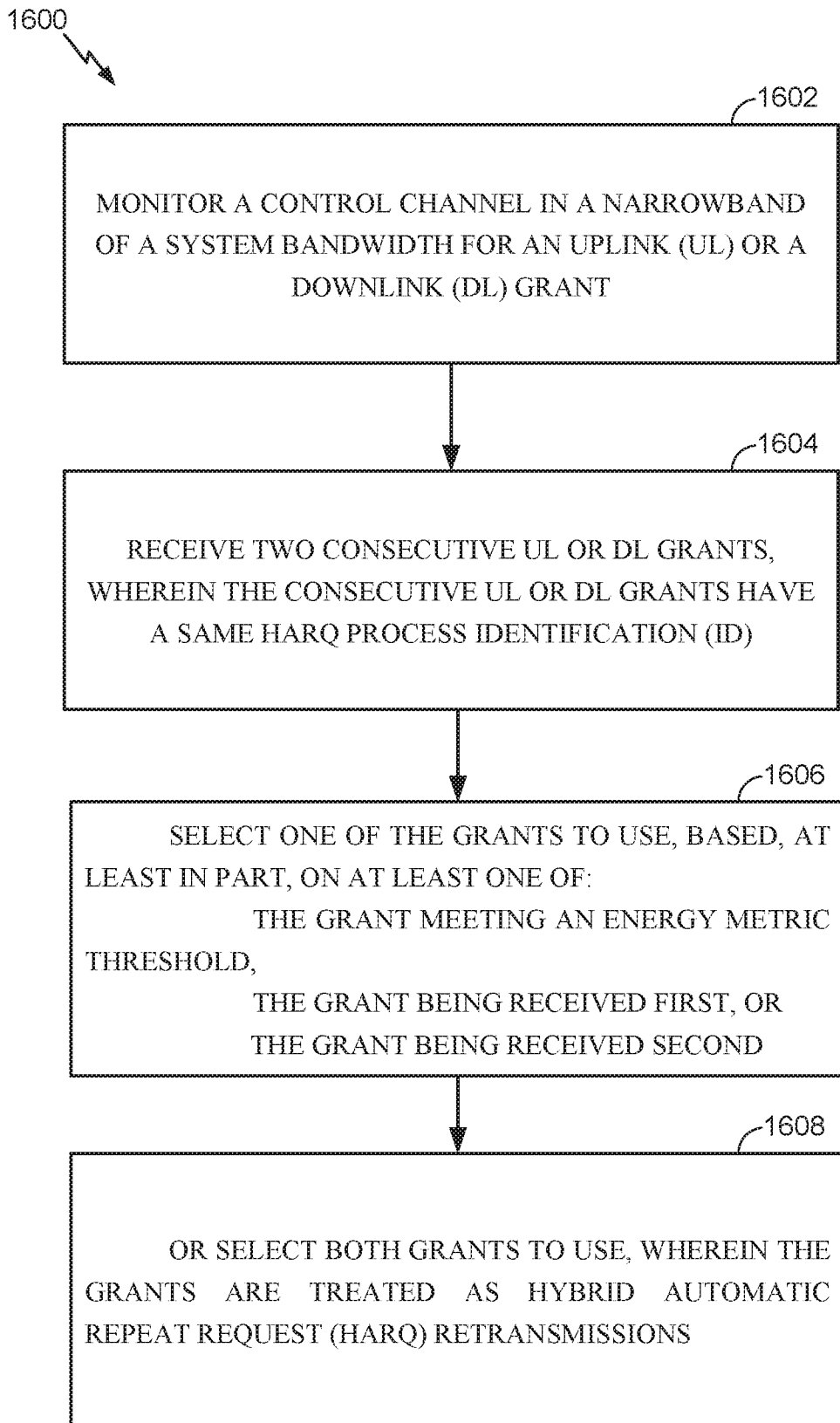

FIG. 16

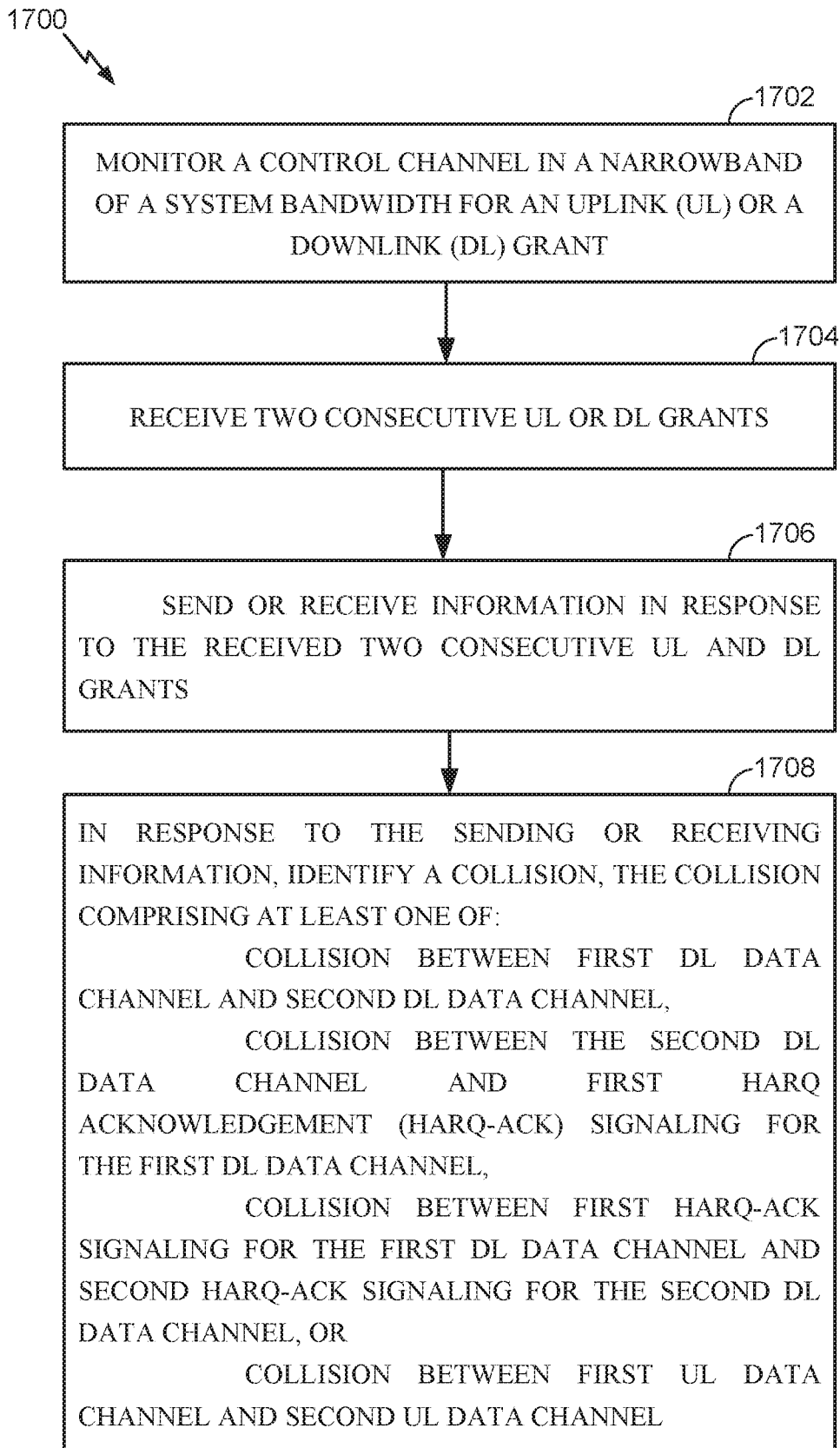

FIG. 17

INTERNATIONAL SEARCH REPORT

International application No.

PCT/CN2018/097029

A. CLASSIFICATION OF SUBJECT MATTER

H04L 29/02(2006.01)i; H04W 74/00(2009.01)i

According to International Patent Classification (IPC) or to both national classification and IPC

B. FIELDS SEARCHED

Minimum documentation searched (classification system followed by classification symbols)

H04W; H04L; H04B

Documentation searched other than minimum documentation to the extent that such documents are included in the fields searched

Electronic data base consulted during the international search (name of data base and, where practicable, search terms used)

CNABS;CPRSABS;CNTXT;CNKI;VEN;JPTXT;WOTXT;EPTXT;USTXT;3GPP:monitor,narrowband,uplink,UL,downlink,DL,grant,interlac+,switch,HARQ,identification,ID,NB-IoT,NPDCCH,NPDSCH,NPUSCH,energy,threshold,TDD

C. DOCUMENTS CONSIDERED TO BE RELEVANT

Category*	Citation of document, with indication, where appropriate, of the relevant passages	Relevant to claim No.
X	ZTE. "Clarification on Rel-14 NPDCCH monitoring" <i>3GPP Draft; R1-1707799</i> http://www.3gpp.org/ftp/tsg_ran/WG1_RL1/TSGR1_89/Docs/ , 06 May 2017 (2017-05-06), Section 2	1-3, 8, 9, 17- 22, 43, 46, 49, 52, 55, 58, 61
A	Huawei et al. "Remaining details for 2 HARQ processes" <i>3GPP Draft; R1-1701754</i> http://www.3gpp.org/ftp/tsg_ran/WG1_RL1/TSGR1_88/Docs/ , 12 February 2017 (2017-02-12), Section 2, figures 1 and 2	24-63
A	CN 103999528 A (INTERDIGITAL PATENT HOLDINGS INC) 20 August 2014 (2014-08-20) the whole document	1-63
A	WO 2017014549 A1 (LG ELECTRONICS INC) 26 January 2017 (2017-01-26) the whole document	1-63
A	US 2017141901 A1 (QUALCOMM INC) 18 May 2017 (2017-05-18) the whole document	1-63

 Further documents are listed in the continuation of Box C. See patent family annex.

* Special categories of cited documents:

"A" document defining the general state of the art which is not considered to be of particular relevance

"E" earlier application or patent but published on or after the international filing date

"L" document which may throw doubts on priority claim(s) or which is cited to establish the publication date of another citation or other special reason (as specified)

"O" document referring to an oral disclosure, use, exhibition or other means

"P" document published prior to the international filing date but later than the priority date claimed

"T" later document published after the international filing date or priority date and not in conflict with the application but cited to understand the principle or theory underlying the invention

"X" document of particular relevance; the claimed invention cannot be considered novel or cannot be considered to involve an inventive step when the document is taken alone

"Y" document of particular relevance; the claimed invention cannot be considered to involve an inventive step when the document is combined with one or more other such documents, such combination being obvious to a person skilled in the art

"&" document member of the same patent family

Date of the actual completion of the international search

19 October 2018

Date of mailing of the international search report

29 October 2018

Name and mailing address of the ISA/CN

STATE INTELLECTUAL PROPERTY OFFICE OF THE
P.R.CHINA
6, Xitucheng Rd., Jimen Bridge, Haidian District, Beijing
100088
China

Authorized officer

WANG, Qiong

Facsimile No. (86-10)62019451

Telephone No. 86- (010) -62411297

INTERNATIONAL SEARCH REPORT
Information on patent family members

International application No.

PCT/CN2018/097029

Patent document cited in search report			Publication date (day/month/year)	Patent family member(s)			Publication date (day/month/year)
CN	103999528	A	20 August 2014	TW	201330558	A	16 July 2013
				SG	11201401068S	A	28 April 2014
				EP	2761955	B1	26 July 2017
				KR	20140071480	A	11 June 2014
				TW	I627849	B	21 June 2018
				EP	3247160	A1	22 November 2017
				JP	2017139796	A	10 August 2017
				TW	201807988	A	01 March 2018
				JP	6122855	B2	26 April 2017
				US	2013083753	A1	04 April 2013
				WO	2013049768	A1	04 April 2013
				JP	2014531856	A	27 November 2014
				CN	103999528	B	07 August 2018
				EP	2761955	A1	06 August 2014
				JP	6367999	B2	01 August 2018
				CA	2850569	A1	04 April 2013
				WO	2017014549	A1	26 January 2017
				EP	3327972	A1	30 May 2018
US	2017141901	A1	18 May 2017	CN	108352971	A	31 July 2018
				AU	2016351566	A1	26 April 2018
				EP	3375122	A1	19 September 2018
				KR	20180084771	A	25 July 2018
				WO	2017083137	A1	18 May 2017
				TW	201720197	A	01 June 2017