

No. 695,577.

Patented Mar. 18, 1902.

E. O. MÖCKEL.

MACHINE FOR CLEANING PLAYING CARDS.

(Application filed May 20, 1901.)

(No Model.)

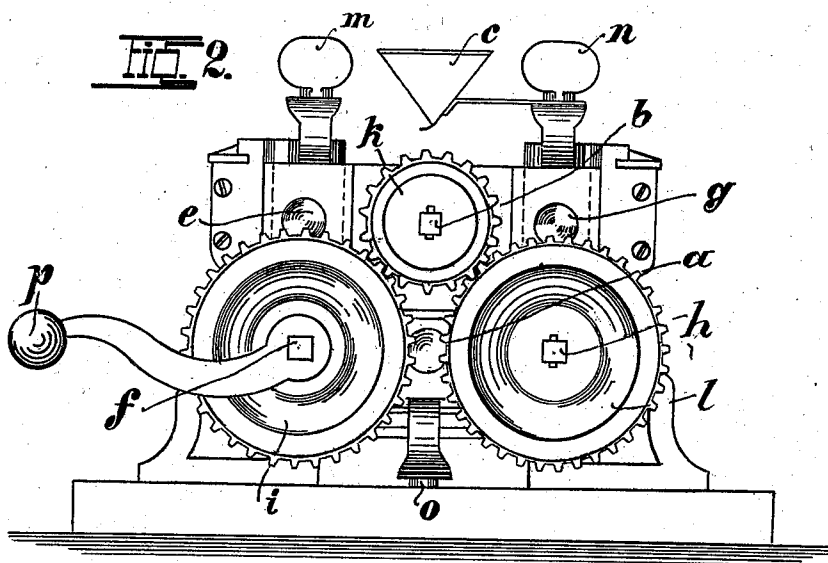
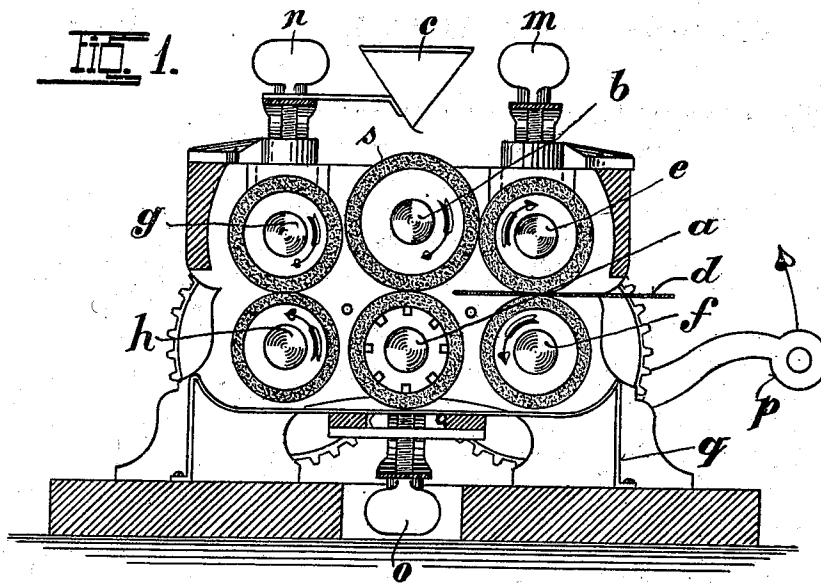

WITNESSES:
Isabella Waldron
Oliver

INVENTOR
Emil Otto Möckel
BY
Richard
ATTORNEYS

UNITED STATES PATENT OFFICE.

EMIL OTTO MÖCKEL, OF CROTTENDORF, GERMANY.

MACHINE FOR CLEANING PLAYING-CARDS.

SPECIFICATION forming part of Letters Patent No. 695,577, dated March 18, 1902.

Application filed May 20, 1901. Serial No. 61,134. (No model.)

To all whom it may concern:

Be it known that I, EMIL OTTO MÖCKEL, master carpenter, of 23 Hauptstrasse, Crottendorf, in the Erz-Gebirge, in the Empire of Germany, have invented Improvements in Machines for Cleaning Playing-Cards; and I do hereby declare the nature of this invention and in what manner the same is to be performed to be particularly described and ascertained in and by the following statement.

This invention relates to the renovation of playing-cards after use, and has for its object to provide a machine which will efficiently flatten the cards bent by use, remove the dirt from them, and finally repolish them, so as to prevent cards which have been in use for some time from adhering together.

I have illustrated my new or improved machine in the accompanying drawings, in which—

Figure 1 is a longitudinal section, and Fig. 2 a rear elevation, of the same.

The machine comprises a stationary roller *a* and five rotary rollers *b e f g h*, of which latter the roller *f* is driven by means of a crank-handle. Upon the shaft of the latter there is mounted a spur-wheel *i*, gearing in the spur-wheel *k* of the roller *b* and which transmits the rotation to a toothed wheel *l*, connected with the roller *h*. The rollers *g* and *e* are driven by friction. All the rollers are provided with a covering, preferably of felt, *s*.

Above the roller *b* is a trough or container *c* for the reception of steatite or any other suitable polishing media. The trough *c* is formed with a slot in its bottom through which the polishing media issues while the machine is being used and falls in a fine stream upon the roller *b*.

The pressure-screws *m n* permit the pressure of the rollers *e g* on the rollers *f* and *h* to be regulated as may be required, while another pressure-screw *o* allows the pressure

of the lower stationary roller *a* to be adjusted against the roller *b* above it.

The machine operates in the following manner: The playing-card *d*, which has been used and become dirty, is inserted between the rollers *e* and *f*, and the latter is then revolved by means of the crank-handle *p*. The card is thereby drawn through the pair of rollers *e* and *f* and reaches the middle pair of rollers *a b*. The rollers *e* and *f* are arranged to remove the rough dirt from the card and also flatten the same when having been bent or curved from repeated use. The final cleaning and polishing of the card is effected between the rollers *a* and *b*. From here the card passes between the pair of rollers *g h*. These latter also flatten the card and wipe off any excess of polishing material, which is caused to drop into the box *q*. If desired, in special cases the card may be passed once more through the machine by reversing it—that it is to say, if in the first instance the face of the card was placed upward in going through the rollers it would now be placed face downward.

Having now particularly described and ascertained the nature of my said invention and in what manner the same is to be performed, I declare that what I claim is—

In combination, a feed-hopper for polishing material, a rotary roller beneath the same, a rotary roller on each side and in contact with said first-named roller, a rotary roller beneath and in contact with each side roller, and a stationary roller between the lower rollers and in contact with the central roller, substantially as described.

In witness whereof I have hereunto set my hand in presence of two witnesses.

EMIL OTTO MÖCKEL.

Witnesses:

OSKAR EICHHOLZ,
B. H. WARNER, Jr.