

(No Model.)

O. MULLER.

CONNECTING BOX FOR SECTIONAL STEAM BOILERS.

No. 368,603.

Patented Aug. 23, 1887.

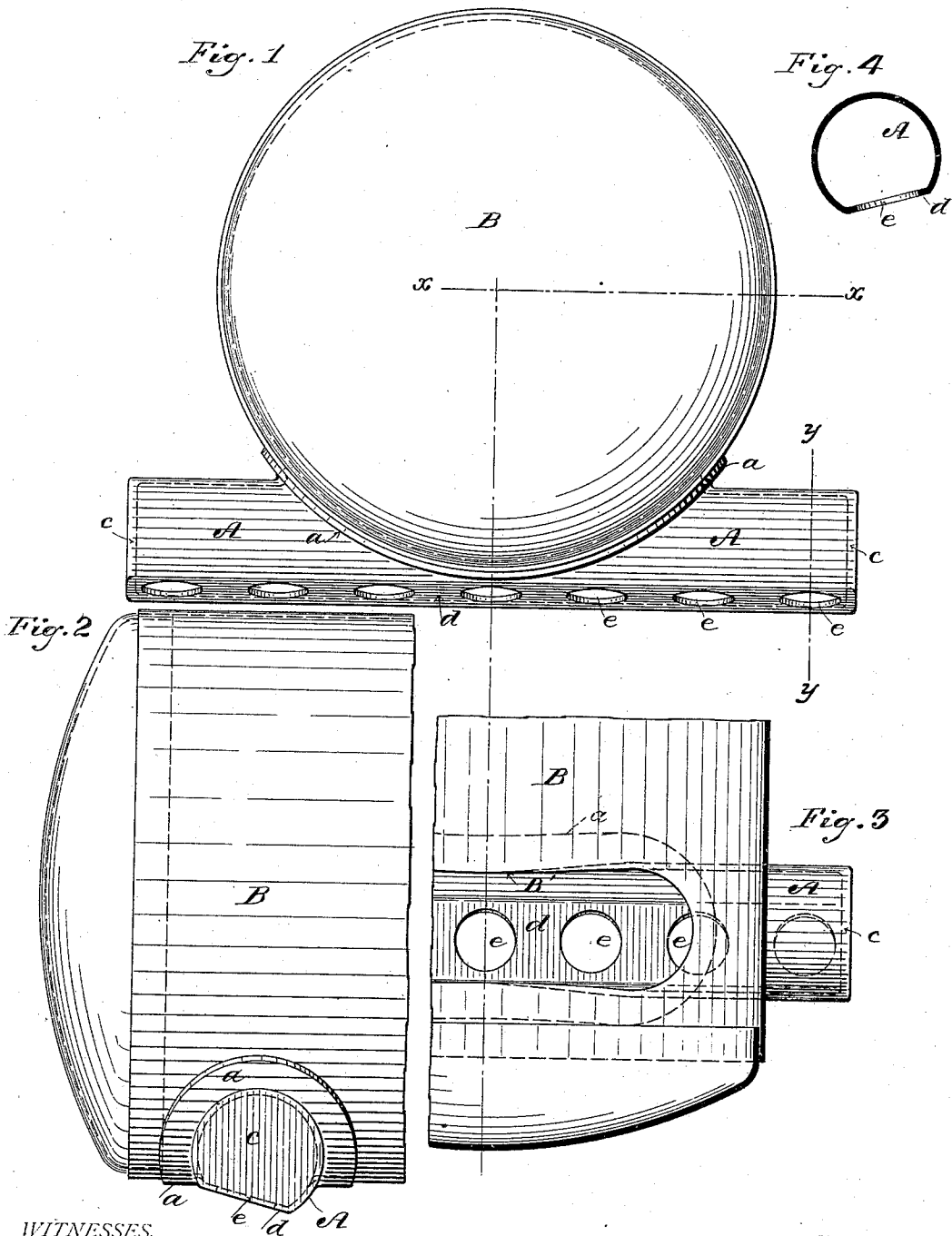

WITNESSES.

Aug. 23, 1887
W. W. Weston

INVENTOR.

Otto Muller
by Chas. N. Jordan
ATTORNEY.

UNITED STATES PATENT OFFICE.

OTTO MULLER, OF NEW YORK, N. Y.

CONNECTING-BOX FOR SECTIONAL STEAM-BOILERS.

SPECIFICATION forming part of Letters Patent No. 368,603, dated August 23, 1887.

Application filed March 3, 1887. Serial No. 229,553. (No model.)

To all whom it may concern:

Be it known that I, OTTO MULLER, a citizen of the United States, residing in the city, county, and State of New York, have invented certain new and useful Improvements in Connecting-Boxes for Sectional Steam-Boilers, of which the following is a specification.

This invention relates to the construction of manifold boxes for use in making a connection between a drum and a series of water-tubes of sectional steam-boilers; and the said invention consists in applying certain novel features of construction to the said boxes, for the purpose of producing them from wrought metal.

In order to enable others skilled in the art to which my invention appertains to understand and use the same, I will proceed to describe the features of its construction, having reference to the accompanying drawings, and subsequently point out in the appended claims its novel characteristics.

Figure 1 is an end elevation of a drum and connecting-box in position thereon; Fig. 2, a side elevation of one end of the same; Fig. 3, a horizontal section (*x x*, Fig. 1) of the same; and Fig. 4, a cross-section (*y y*, Fig. 1) of the connecting-box.

The connecting-box or manifold A consists of a chamber approximately cylindrical, closed at the ends, and having an oblong opening on its upper side which matches the opening B' of the drum B, Fig. 3, and for the purpose of being riveted or welded thereon the said tube-opening is provided with a flange, *a*, having a saddle-like form, which coincides in curvature with the external circumference of the drum. The opening B' and flanged opening of the chamber A, as will be observed by an inspection of Fig. 3, conform in outline with the figure described by the intersection of the two cylinders, the aperture having a slightly con-

tracting curvature toward its center, in accord with the original cylindrical form of the chamber from which the manifold is produced. The opposite or lower side of the chamber is flattened throughout its length, presenting a surface, *d*, of sufficient width, as more clearly shown by Fig. 4, for the reception of tube-perforations *e*, into which tubes may be expanded for connecting sections of water tubes in a manner common to water-tube boilers. The flattened portion *d*, corresponding in cross-section with the chord of the arc of the partly-circular chamber, may be formed with an incline in either direction with relation to the horizontal axial plane of the drum or made parallel therewith. The ends *c* of the chamber A are formed of plates welded therein or otherwise secured in place.

What I claim as my invention, and desire to secure by Letters Patent, is—

1. A wrought-metal connecting-box for a water-tube boiler, consisting of a chamber approximately cylindrical, one side of which is opened and flanged to fit the side of a drum, substantially as described.

2. A wrought-metal connecting-box for a water-tube boiler, consisting of a chamber flattened upon one side and perforated for the reception of tubes, and opened and flanged upon another side to fit the side of a drum, substantially as described.

3. A wrought-metal connecting-box for a water-tube boiler, consisting of a chamber approximately cylindrical, closed at the ends, perforated on one side for the reception of tubes, and fitted to be secured to the side of a drum, substantially as specified.

OTTO MULLER.

Witnesses:

CHAS. W. FORBES,
AUG. CREVELING.