

A. FRAISSINET.
 TUBE CLEANER.
 APPLICATION FILED MAR. 31, 1911.

1,002,255.

Patented Sept. 5, 1911.

2 SHEETS—SHEET 1.

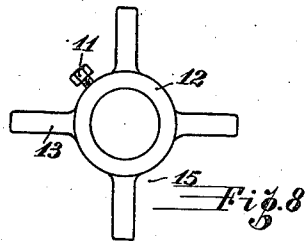
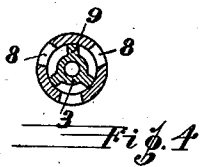
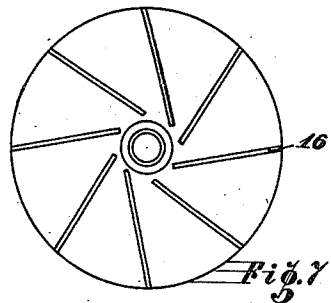
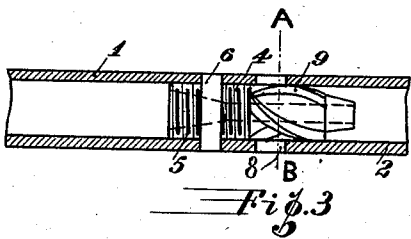
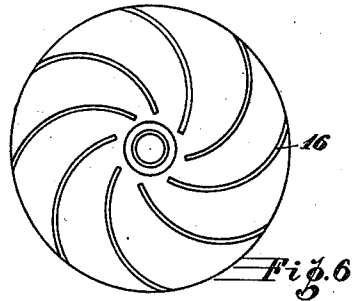
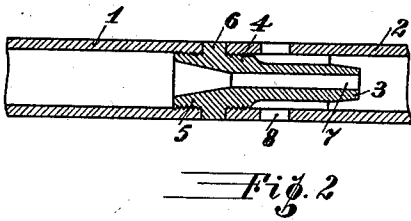
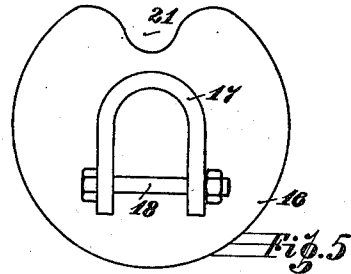
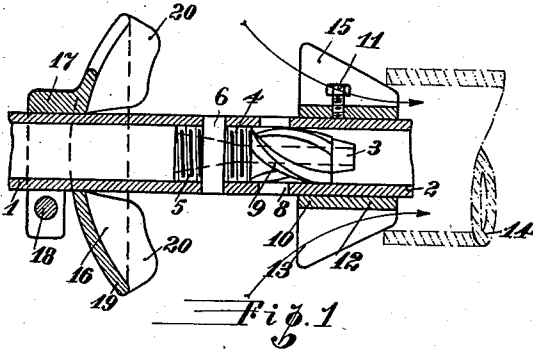

Witnesses

Ernst Wilhelm Fraissinet
 Rechtsanwalt

Felix Müller

Inventor

Alfred Fraissinet

A. FRAISSINET.
 TUBE CLEANER.
 APPLICATION FILED MAR. 31, 1911.

1,002,255.

Patented Sept. 5, 1911.

2 SHEETS—SHEET 2.

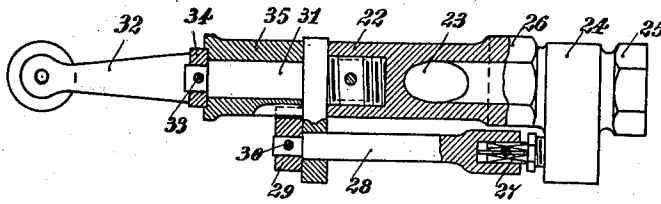

Fig. 9

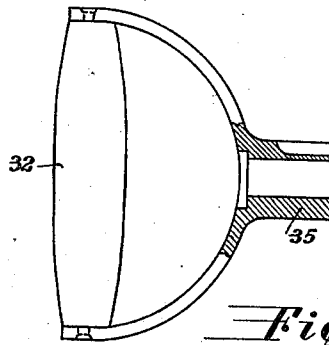

Fig. 10

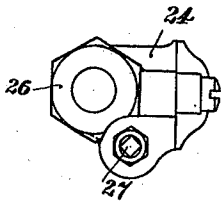

Fig. 11

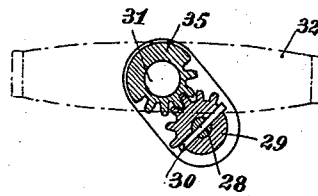

Fig. 12

Witnesses
for Wilhelm Fraissinet
 Rechtsanwalt.
Felix Müller

Inventor
Alfred Fraissinet

UNITED STATES PATENT OFFICE.

ALFRED FRAISSINET, OF CHEMNITZ, GERMANY.

TUBE-CLEANER.

1,002,255.

Specification of Letters Patent.

Patented Sept. 5, 1911.

Application filed March 31, 1911. Serial No. 618,144.

To all whom it may concern:

Be it known that I, ALFRED FRAISSINET, a subject of the Emperor of Germany, and a resident of Chemnitz, Saxony, Germany, have invented an Improved Tube-Cleaner, of which the following is a specification.

The present invention relates to a tube-cleaner for steam boilers and the like of the kind effecting the cleaning by means of compressed gaseous fluid, such as steam and the like, and by means of air sucked in by such fluid, a whirling motion being imparted to the air-mixture by spirally disposed ribs fitted in or about the feeding nozzle.

According to the present invention, which partly consists in various details of construction of the nozzle itself, an adjustable shield is provided for the purpose of preventing other than the hot air rising along the wall of the boiler from entering the tubes. By thus excluding cold air from the tubes, the cooling of the boiler by the cleaning process and a condensation of the cleaning fluid, with consequent formation of mud and incrustation in the tubes, is prevented.

Whereas in previous arrangements the supply of compressed fluid is generally regulated by the depression, with the finger, of a valve either in opposition to the pressure or to a still more powerful spring, means are in the present instance provided for regulating the fluid supply by turning the operating handle which is capable of rotary motion and which is geared to a rotary slide valve for the purpose. In this manner the operation of the device is considerably facilitated.

The invention is illustrated by way of example in the accompanying drawings, Figures 1, 2, 3 representing longitudinal sections of the front part of the apparatus, Fig. 1 showing also the shield and the nozzle-head, Fig. 4, a cross-section on the line A—B of Fig. 3, Fig. 5, a rear view of the shield, Figs. 6 and 7, front views of different constructions of the same, Fig. 8, a view of the nozzle-head, Fig. 9, a longitudinal section of the rear part of the apparatus, Fig. 10, a view, partly in section, of the operating handle, Fig. 11, a front view of the valve casing, and Fig. 12, a sectional front view of the gearing by means of which the valve is operated.

According to the invention the apparatus is composed of two pipe ends 1 and 2, of uniform cross-section, which are screwed together over a contracted nozzle 3 having on

its rear part two screw-threaded portions 4 and 5 for the reception of the pipes, the nozzle being projected into the front pipe 2. A shoulder 6 between the screw-threaded portions serves as abutment for the ends of the pipes. The duct 7 of the nozzle 3 is conical at the rear and cylindrical at the front; the front end of the nozzle is moreover tapered on the outside. Apertures 8 are provided in the wall of the pipe 2 to admit air from the outside, and such air is set in a whirling motion by spirally arranged ribs 9 fitted between the projecting part of the nozzle 3 and the pipe 2 and extended through a suitable distance. The ribs, which may have a more forward position than indicated in the drawings, may be connected either to the nozzle or to the pipe 2.

For the purpose of applying the cleaner to the smoke tubes a head 10 is provided which is adjustably arranged on the pipe 2. This head consists of a sleeve 12 to which forwardly tapering ribs 13 are connected. The ribs engage the smoke tube with their edges and admit air through the spaces 15 between them into the tube. A whirling motion is imparted to such air by arranging the ribs 13 spirally on the sleeve 12. The direction in which the ribs are carried must be the same as that of the ribs 9. A set screw 11 fitted in the sleeve enables the head to be secured to the pipe in various positions.

In order to guide the hot air, rising along the boiler wall, into the apertures 8 and the spaces 15, and to exclude the cold air disposed at some distance from the boiler wall, a shield 16 is provided which is adjustably arranged on the pipe 1 by means of a clamp 17 and a screw-bolt 18. The side of the shield-plate 19 which faces the boiler is fitted with vanes 20, such vanes being either spiral-shaped, as shown in Fig. 6, or set in an oblique position, as shown in Fig. 7. These vanes serve to impart a rotary motion to the air before its entrance into the passages between the ribs 9 and 13, and are set in the same direction as the latter. A notch 21 may be provided in the shield-plate 19 to allow the front part of the apparatus to be surveyed. For the same purpose the shield may be made partly or entirely of some transparent material such as mica or the like.

For regulating the fluid supply to the nozzle the following arrangement is pro-

60

65

70

75

80

85

90

95

100

105

110

vided, reference being had to Figs. 9 to 12 of the drawings: A casing 24, containing any known kind of rotary slide valve, is fitted on opposite sides with screw-sockets 5 25 and 26. The socket 25 is screwed to the pipe 1; the other socket is screwed to a cylindrical body 22 through a laterally opening duct 23 of which the fluid is conducted to the valve. The duct 23 is for that purpose 10 connected to the steam space of the boiler or to any other source of compressed gaseous fluid. The valve is operated by a spindle 27, to the outer, squared end of which a socket-wrench 28 is applied. The 15 outer end of the wrench 28 is rotatably held in a bracket provided on the outer end of the body 22 and is fitted with a toothed wheel 29 connected thereto by a cross-pin 30. On a pin 31, screwed into the end of the body 20 22, an operating handle 32 is swivelly mounted by means of its stem 35. A collar 34 on the outer, reduced end of the pin 31 retains the handle on the pin, the collar being in its turn retained by a cross-pin 33. 25 The lower part of the handle stem 35 is formed with teeth which mesh with the teeth of the wheel 29. When, therefore, the handle is turned on the body 22, the wrench 28 and the valve must be turned with it. 30 Since the pressure on the slide valve does not materially interfere with its movement, and since the operator is able to apply his whole hand power to the operating handle 32, it is evident that the improved device 35 will be far more easy to manipulate than those in which a valve has to be depressed by a finger. Besides, the valve always remains in adjusted position, which is a further advantage. 40 The device is operated in the usual manner, the nozzle-head 10 being applied to the smoke tubes 14, as shown in Fig. 1, and the valve opened by turning the handle 32. Owing to the velocity of the compressed 45 fluid discharged by the nozzle 3, air is sucked in through the apertures 8 and set in a whirling motion by the spiral ribs 9. This motion of the air is also transmitted to the fluid discharged by the nozzle 3, a thorough 50 mixing of the two being thus effected. As the air-mixture is discharged into the tube by the pipe 2, more air is sucked in through the spaces between the ribs 13 of the head 10, this air being also set in rotation owing to the spiral position of the ribs. The shield 16 prevents other than the hot air rising 55 along the boiler wall from entering the apertures 8 and the spaces 15, the cold air from the outside being excluded. The vanes 20 of the shield set the air in circulation before it enters the apertures 8 and the spaces 15.

The general effect of the arrangement is therefore to introduce a large quantity of 35 hot air into the tubes together with the com-

pressed fluid, the moisture of which is thus absorbed and prevented from adhering to the walls of the tubes for the formation of mud and incrustation. The tubes are effectively cleared of soot and other deposits by 70 the speedily circulating air-mixture, and the boiler is not cooled by the operation since cold air is excluded.

When the device is used for cleaning the 75 outside of water tubes, superheaters, and the like, the nozzle-head 10 and, if need be, also the shield 16, may be removed. The construction of the device allows of making its external parts sufficiently strong to resist shocks, and since the internal parts are 80 well covered up and protected, no damage need be incurred to the same if the cleaner is dropped or otherwise roughly handled.

I claim:—

1. A tube cleaner of the character described, comprising a nozzle having at its 85 rear end a shoulder and screw-threaded portions at both sides of said shoulder, a pipe supplying compressed gaseous fluid screwed from the rear against said shoulder, another 90 pipe screwed from the front against the same so as to inclose the front part of the nozzle, spirally arranged ribs between the nozzle and wall of the latter pipe, said 95 latter pipe having apertures to admit air into the spaces between the ribs, and means for shielding said apertures against cold air, substantially as and for the purpose set forth.

2. A tube cleaner of the character described, comprising a nozzle having at its 100 rear end a shoulder and screw-threaded portions at both sides of said shoulder, pipe ends of a diameter equal to that of the 105 shoulder screwed against the latter from opposite sides, a collar having forwardly tapering spirally arranged ribs adjustably fitted on the pipe for holding the apparatus in position in the nozzle of the tube to 110 be cleaned, means for admitting air into the front pipe, and means for shielding the air inlets from cold air.

3. A tube cleaner of the character described, comprising a nozzle having at its 115 rear end a shoulder and screw-threaded portions at both sides of said shoulder, pipe end of a diameter equal to that of the shoulder screwed against the latter from 120 both sides, the front pipe having apertures to admit air to the nozzle, spirally arranged ribs between the nozzle and the pipe for putting such air into circulation, an adjustable shield on the rear pipe to prevent other than 125 the hot air rising along the boiler wall from entering the apertures, and forwardly directed spirally disposed vanes on said shield to set the air in circulation.

4. In a tube cleaner of the character described a rotary valve for regulating the 130 fluid supply, a cylindrical body screwed to

the valve casing and provided with a lateral port admitting fluid to the valve, an operating handle swiveled to the outer end of the cylindrical body, and connections between
5 the swiveled handle and the actuating spindle of the valve allowing the valve to be operated by the turning of the handle.

5. In a tube cleaner of the character described, a rotary valve for regulating the
10 fluid supply, a cylindrical body screwed to the valve casing, means for admitting fluid through the body to the valve, an operating handle, having teeth formed on its stem,

swivelly held by means of its stem at the outer end of the cylindrical body, a socket-
wrench arranged parallel with the body and
15 connected with its socket to the actuating spindle of the valve, and a toothed wheel on the rear end of the wrench meshing with
the teeth of the handle so that the valve
20 can be operated by the turning of the handle.

ALFRED FRAISSINET.

Witnesses:

ALBERT R. MORAWETZ,
RUDOLPH FRICKE.

Copies of this patent may be obtained for five cents each, by addressing the "Commissioner of Patents,
Washington, D. C."
