



PATENT SPECIFICATION

(11) S86616

(21) Application No. S2014/0318

(22) Date of Filing of Application: 19/12/2014

(45) Specification Published: 13 January 2016

(51) Int. Cl. (2015.01)
E06C 9/00

(54) Title: Folding fire-escape

(72) Inventor: NOEL O'ROURKE

(73) Patent Granted to: NOEL O'ROURKE, Irish, 65 Lakeside Gardens, Kilminchy, Portlasoise,
Co Laois, Ireland

Title

Folding fire-escape

Field of the Invention

- 5 The present invention relates to a folding fire escape. In particular the invention relates to a new type of folded fire escape.

Description of the Drawings

10 Referring now to the drawings and initially to Figures 1, 2 and 3, there is a folding fire escape comprising a support bracket assembly (1) and additional supporting brackets (2, 3). The support assembly bracket (1) comprises a single U shaped support and an additional support bracket (2, 3), which when combined form a secure wall mounted base assembly support and are bolted to the wall, as can be seen in Fig 8.

15 Fig 4 shows two flat aluminium supports with three hinges welded on to them which are then bolted together comprising the additional support brackets. Referring to Figures 5 and 9, component (4) is the base of the folding fire escape and has the escape ladder (9) attached to it, which is shown in an unfolded state Fig 5. Figures 5 and 6 shows the unfolded state of the folding fire escape, component (6) is the fireproof canvas attached to the frame and (9) is the fire escape ladder attached. The
20 folding fire escape platform base (4) will be illuminated with luminous paint especially in the areas of the railings, the floor of the platform and the steps of the ladder.

Fig 7 shows the support assembly bracket (1) mounted on the wall attached to the folding fire escape base (4) in its open state, showing the railings (5) and the canvas
25 (6) with the folding fire escape ladder (9) in its closed state.

Fig 8 shows the folding fire escape in its closed assembled position. Fig 9 shows the folding fire escape in its open state.

In addition the folding fire escape can be covered with a protective plan.

30 Summary of the Invention

According to the invention there is provided, as set out in the appended claims, a folding fire escape comprising: an aluminium platform; an aluminium ladder; a folding railing with non-flammable canvas attached on three sides; a release lever mounted on the inside wall of the house, these four main components form a folding fire

escape, whereby, three components will be fitted on the outside wall of the bedroom or bathroom window.

A console or bracket is affixed outside on the wall, positioned under the window sill and alongside the bedroom/bathroom window. The folding fire escape is then hinged to the console or bracket in five positions, two hinges are situated on the top right and left corners, three are situated one to the right and one to the left and the fifth in the middle on the bar of the console or bracket. The five hinges are made of steel which are affixed to both the console or bracket and the folding fire escape base. The hinge bolts are of steel and are fitted with spring clips for security. There is an additional feature to the console or bracket; three 90° angles are also attached to the outside wall for further strength and support for the platform in its unfolded escape position. The folding fire escape platform base is comprised of aluminium frame, which is constructed of square aluminium profile. The folding fire escape base floor is covered with aluminium mesh wire, whereby an opening is allowed on the front right hand side for the escape ladder which is mounted on the underside and front right hand corner; it unfolds downwards to an angle of 45° to the ground.

A 16mm hole is drilled through the house wall into the bedroom/bathroom to allow the release lever to be fitted on the inside wall which is situated beside the bedroom/bathroom window. The folding function of the folding fire escape will be released from the inside of the room in question whereby all components of the folding fire escape will on release automatically unfold into its escape position.

The main folding mechanics are found on the side railings, they fold into each other by means of a telescopic function aided by two spring hinges. When unfolding they slide and click into a vertical position creating a safe and secure railing, a non-flammable canvas is provided to eliminate any visual confusion.

When the folding fire escape is in its folded or closed state, it will stand approximately 220mm from the house wall allowing the window to open and does not obstruct in any way.

30 **Detailed Description**

According to the invention there is provided, as set out in the appended claims, a folding fire escape comprising: an aluminium platform (4); an aluminium ladder (9); a folding railing (5) with non-flammable canvas (6) attached on three sides; a release lever (8) mounted on the inside wall of the house, these four main components form

a folding fire escape, whereby, three components will be fitted on the outside wall of the bedroom or bathroom window.

A console or bracket (1) is affixed outside on the wall, positioned under the window sill and alongside the bedroom/bathroom window. The folding fire escape is then hinged to the console or bracket (1) in five positions as shown in Fig 1 and 2, two hinges are situated on the top right and left corners, three are situated one to the right and one to the left and the fifth in the middle on the bar of the console or bracket. The five hinges are made of steel which are affixed to both the console or bracket (1) and the folding fire escape platform (4). The hinge bolts are of steel and are fitted with spring clips for security. There is an additional feature to the console or bracket (1), three 90° angles, as shown in Fig 2, are also attached to the outside wall for further strength and support for the aluminium platform (4) in its unfolded escape position.

The folding fire escape platform (4) is comprised of an aluminium frame, which is constructed of square aluminium profile. On the folding fire escape platform base as shown in Fig 5, the floor is covered with aluminium mesh wire. An opening is allowed on the front right hand side for the folding escape ladder (9) which is mounted on the underside and front right hand corner. When opened the ladder unfolds downwards to an angle of 45° to the ground.

A 16mm hole is drilled through the house wall into the bedroom/bathroom to allow the release lever (8) as shown in Fig 8, to be fitted on the inside wall which is situated beside the bedroom/bathroom window. The folding function of the folding fire escape as shown in Fig 6, will be released from the inside of the room in question by the release lever (8) whereby all components of the folding fire escape will on release automatically unfold into its outward escape position. The main folding mechanics are found on the side railings, as shown in Fig 7, they fold into each other by means of a telescopic function aided by two spring hinges. When unfolding they slide and click into a vertical position creating a safe and secure railing (5), a non-flammable canvas (6) is provided to eliminate any visual confusion. When the folding fire escape is in its folded or closed state, it will stand approximately 220mm from the house wall allowing the window to open and does not obstruct in any way.

The folding fire escape which is mounted on the outside wall surrounding the window will when released from the inside room, will eject outwards from the house wall and fall downwards to a horizontal position, at time release an attached stable folding escape ladder to the ground or to the platform underneath, so that all occupants can reach safety.

It should be emphasized that the above-described embodiments of the present teaching, is a possible example of implementation, merely set forth for a clear understanding of the principles. Many variations and modifications may be made to the above-described embodiment without substantially departing from the spirit and principles of the invention. All such modifications are intended to be included herein within the scope of this disclosure and the present invention and protected by the following claims.

15

20

25

30

Claims

1. A folding fire escape comprising:
a support bracket assembly (1) and supporting brackets (2, 3) providing a
secure wall mounted base for:
5 an aluminium platform (4),
 an aluminium ladder (9),
 and a folding railing (5) with a non-flammable canvas (6) attached on
 three sides;
and a release lever (8) mounted on the inside wall of a house wherein the
10 support assembly bracket (1) is mounted to the outside wall of a dwelling, the
 supporting brackets (2, 3) being attached to this bracket (1) and the folding
 rail (5).
2. A folding fire escape as claimed in 1 wherein the aluminium platform (4) is
15 optionally partially covered with a mesh wire with an opening remaining
 uncovered for the position of the escape ladder (9).
3. The folding fire escape of any preceding claim wherein the platform (4), the
20 ladder (9) and the folding rail (5) are connected with bolts and hinges to the
 support assembly bracket (1) and the supporting brackets (2,3), which allows
 ease of operation of the folding fire escape.
4. The folding fire escape of any preceding claim wherein the platform (4) is
25 illuminated with luminous paint in the areas of: the railings, the floor of the
 platform and the steps of the ladder.
5. The folding fire escape as substantially hereinbefore described with reference
30 to the accompanying description and / or drawings.

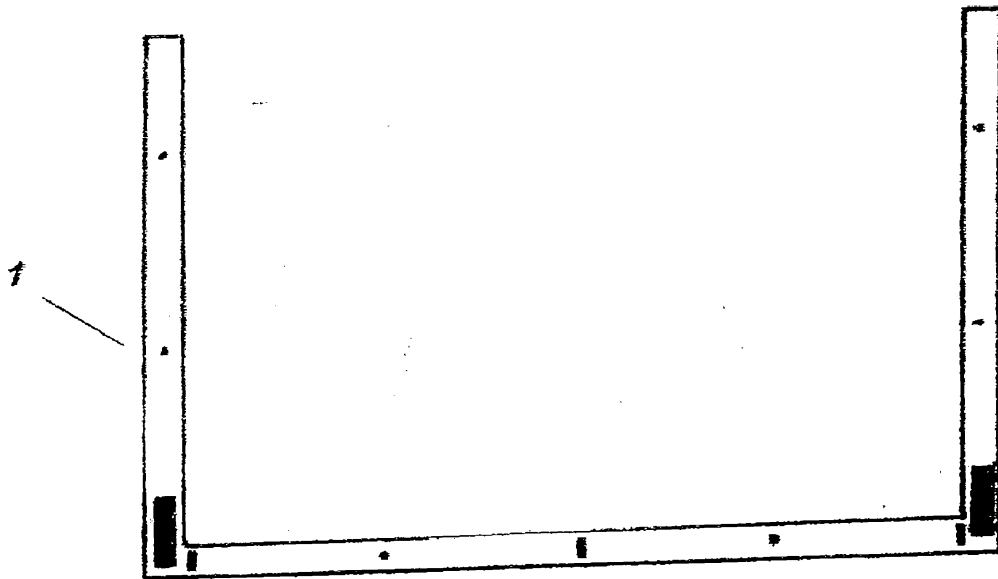

Fig 1

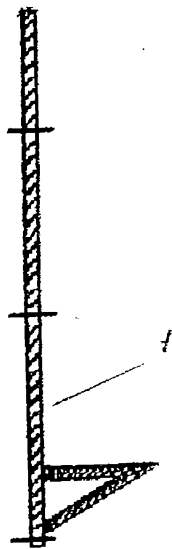

Fig 2

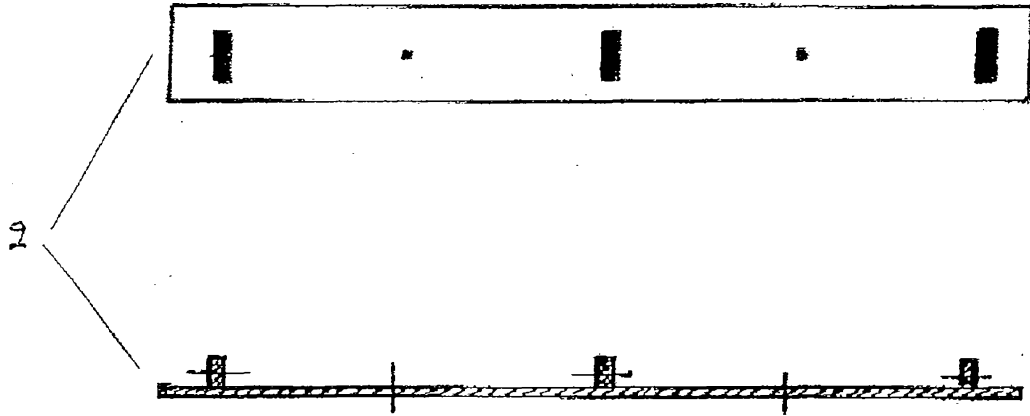

Fig 3

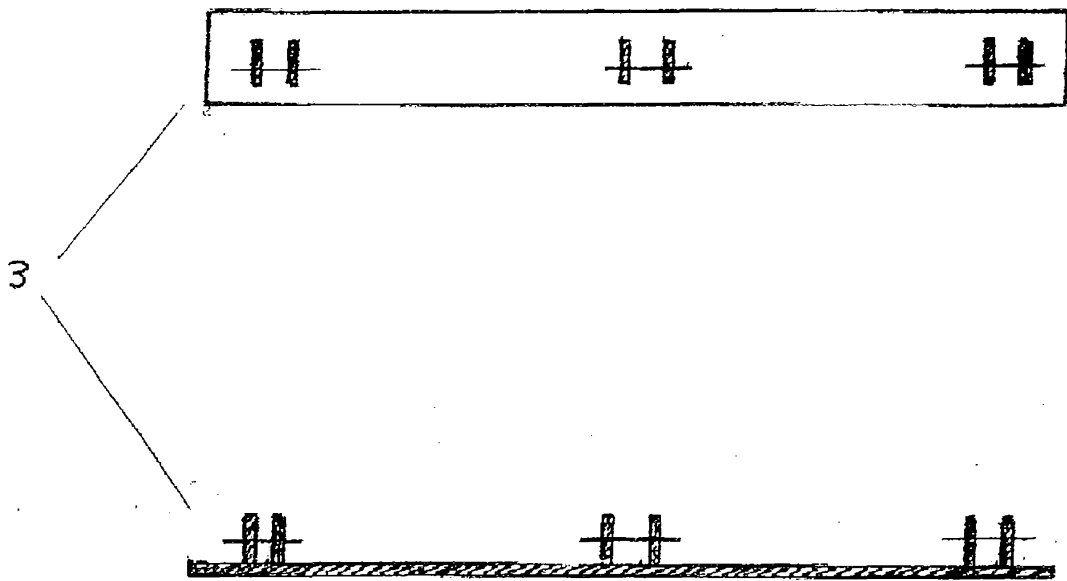

Fig 4

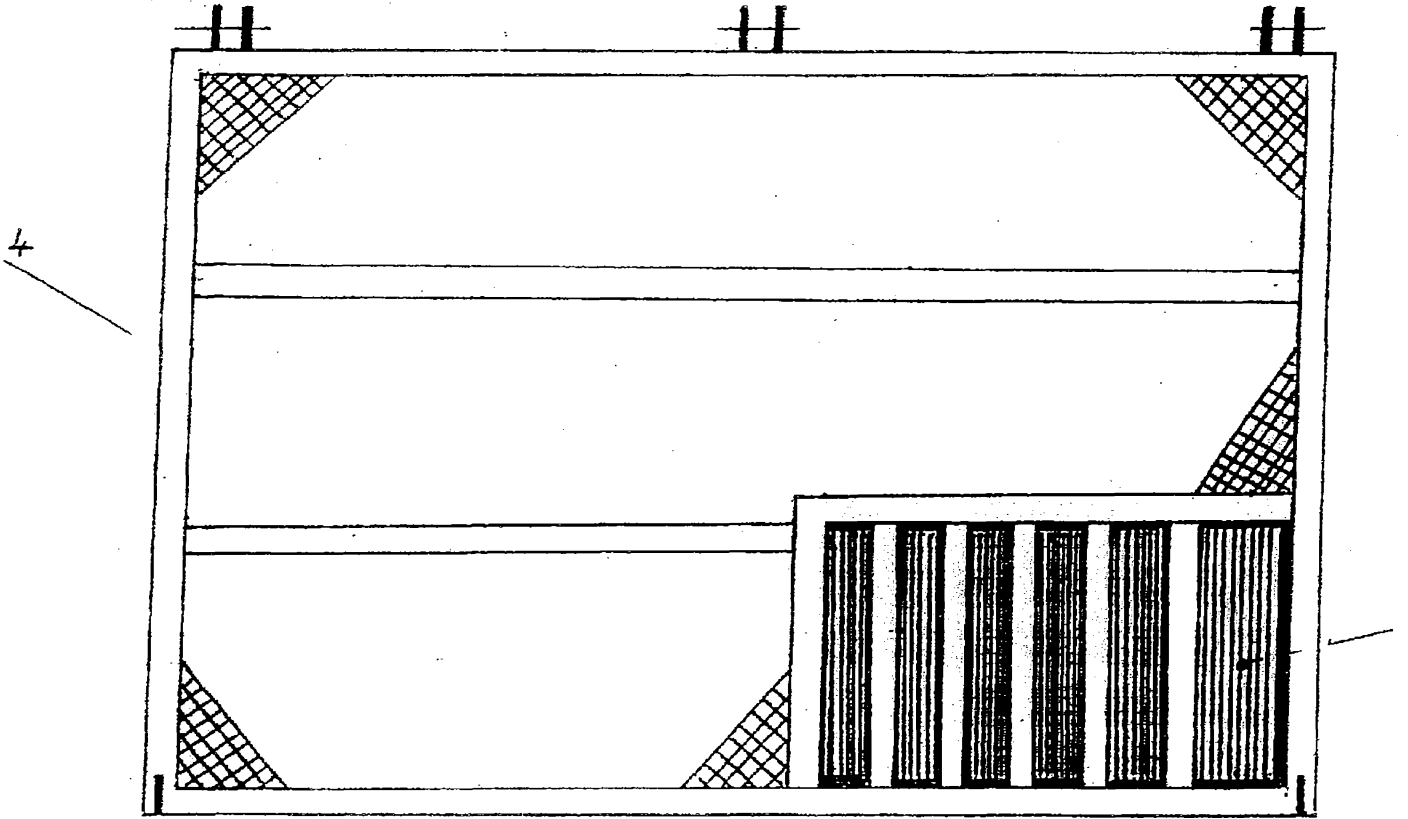

Fig 5

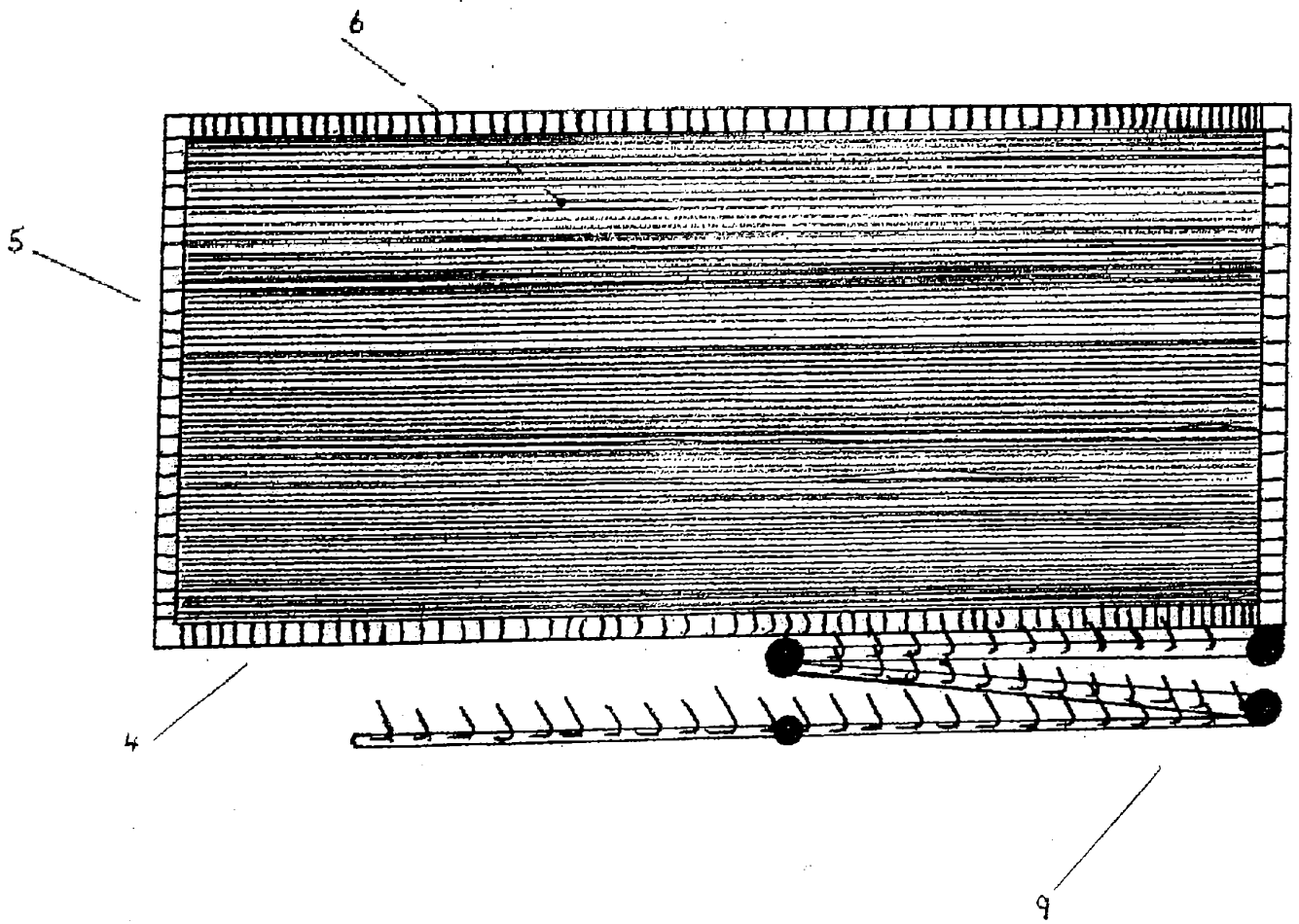

Fig 6

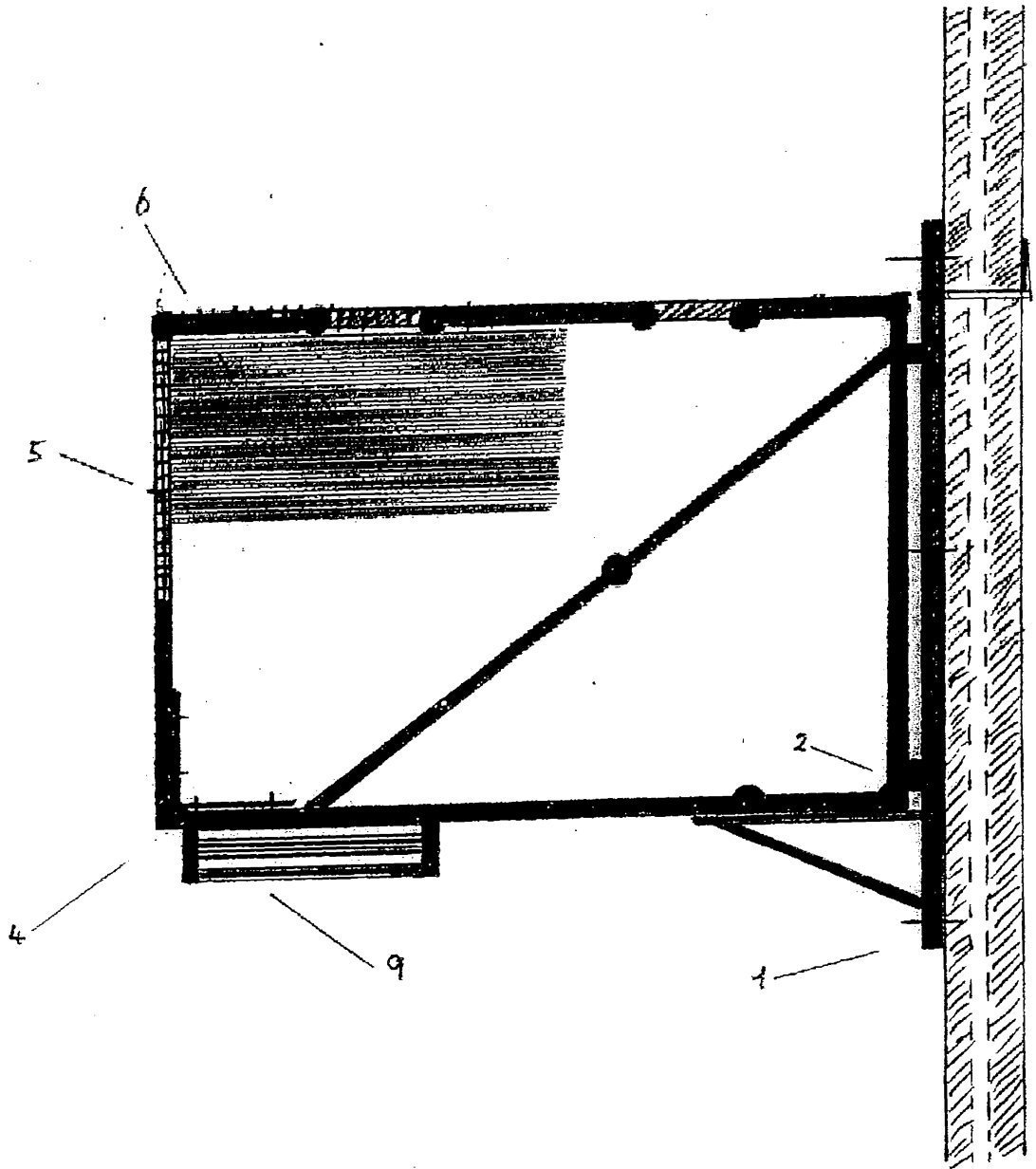

Fig 7

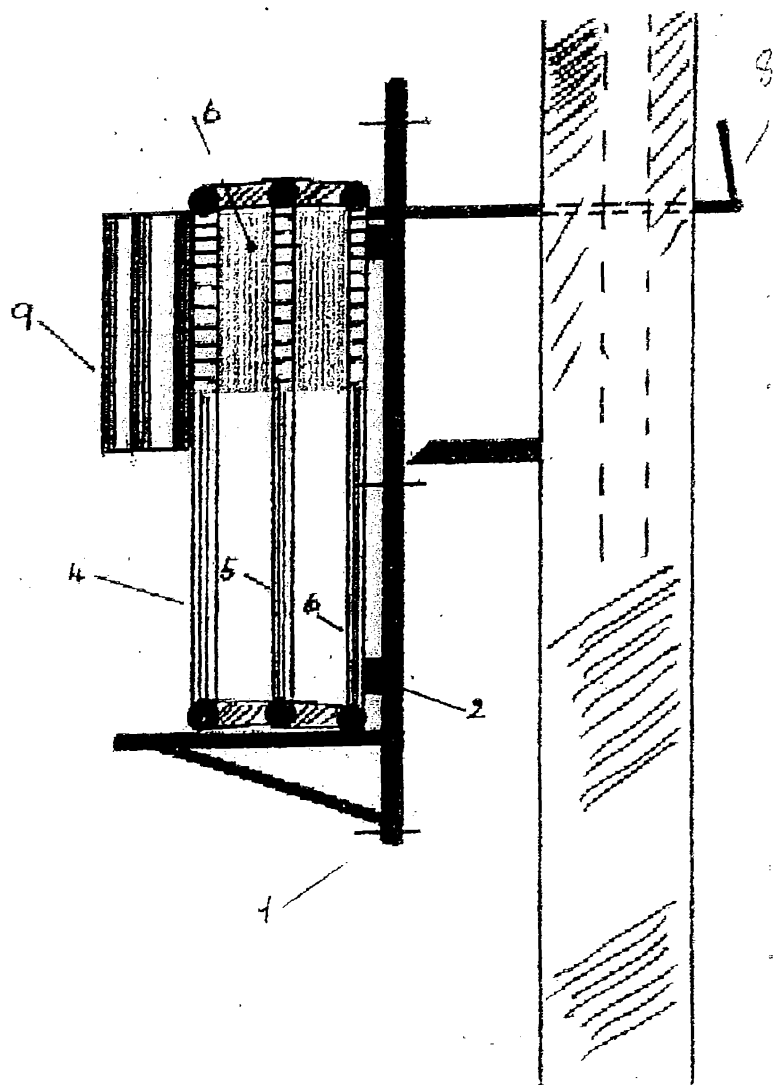

Fig 8

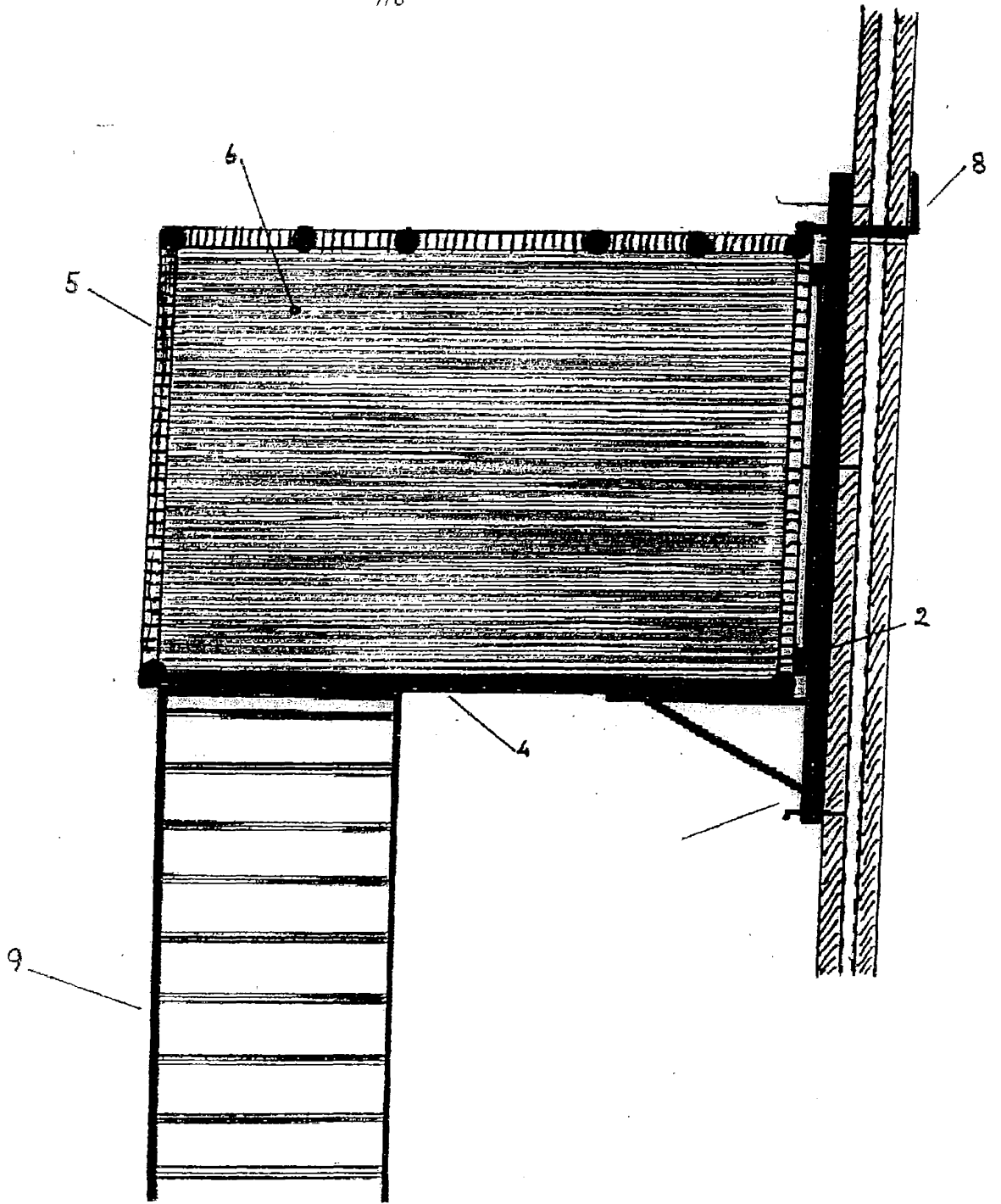

Fig 9