

A. WILZIN.

MECHANICAL FEEDING APPARATUS FOR MACHINES FOR CLOSING METAL CONTAINERS.

APPLICATION FILED JULY 22, 1908.

Patented July 18, 1911.

998,316.

3 SHEETS—SHEET 2.

Fig. 2.

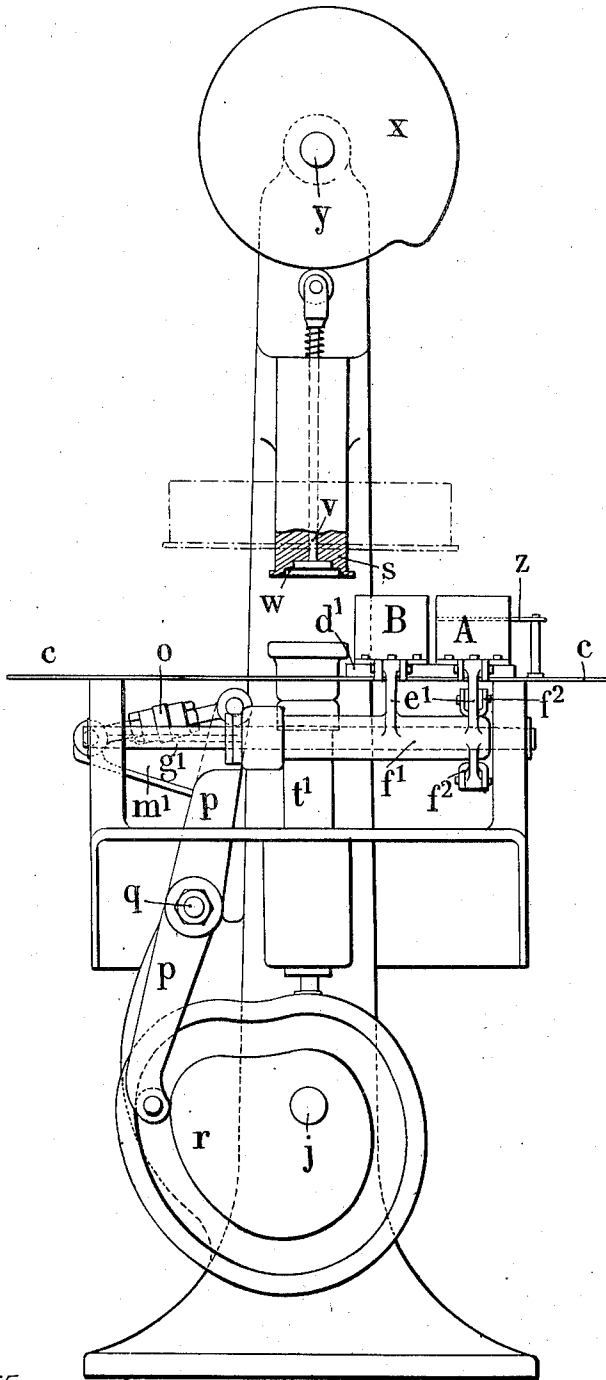

WITNESSES

G. V. Rasmussen
John A. Stebbins

INVENTOR

ARTHUR WILZIN
BY
Bremer Knauth
ATTORNEYS

A. WILZIN.

MECHANICAL FEEDING APPARATUS FOR MACHINES FOR CLOSING METAL CONTAINERS.

APPLICATION FILED JULY 22, 1908.

998,316.

Patented July 18, 1911.

3 SHEETS-SHEET 3.

Fig. 3.

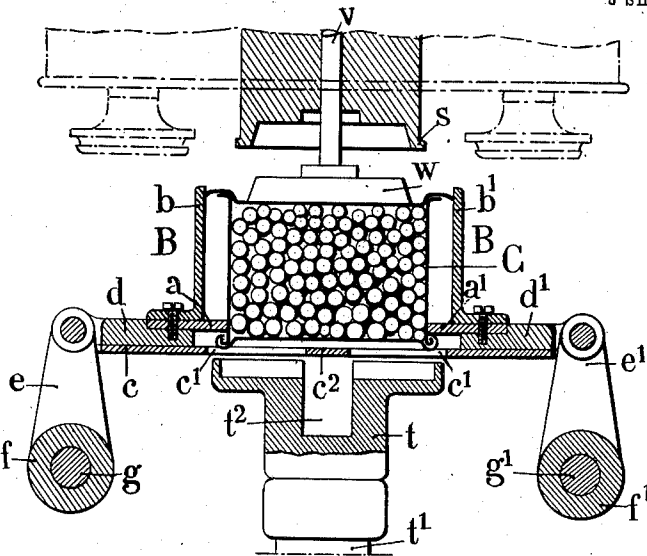

Fig. 6.

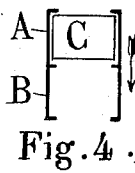

Fig. 7.

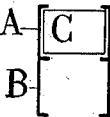

Fig. 8.

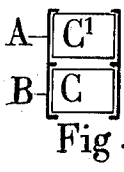
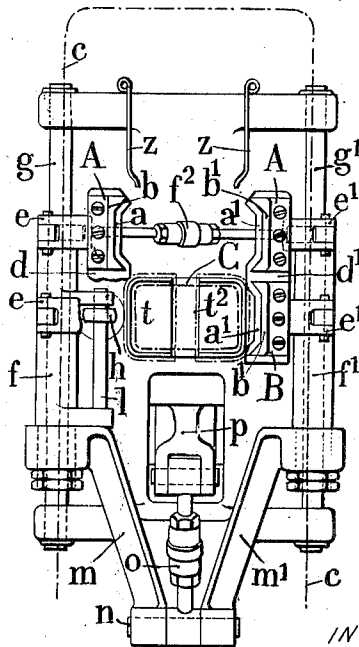
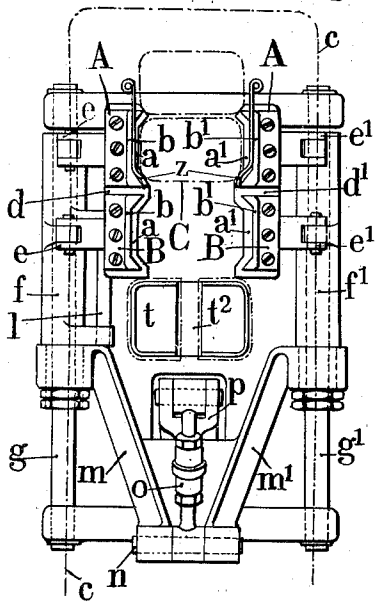

Fig. 9.



WITNESSES:

G. V. Rasmussen
 J. A. Sehnbeck

INVENTOR

ARTHUR WILZIN

BY

Briesen & Krauth
 ATTORNEYS

UNITED STATES PATENT OFFICE.

ARTHUR WILZIN, OF ST.-OUEN, FRANCE.

MECHANICAL FEEDING APPARATUS FOR MACHINES FOR CLOSING METAL CONTAINERS.

998,316.

Specification of Letters Patent. Patented July 18, 1911.

Application filed July 22, 1908. Serial No. 444,868.

To all whom it may concern:

Be it known that I, ARTHUR WILZIN, of 100 Boulevard Victor Hugo, St.-Ouen, Seine, Republic of France, engineer, have invented a Mechanical Feeding Apparatus for Machines for Closing Metal Containers, of which the following is a full, clear, and exact description.

The closure of containers for preserved goods after the same have been filled, always necessitates special precautions in order to maintain the cover in place at the moment of closure, in view of the fact that it is very often impossible to bring about the complete engagement of the cover with the container in consequence of the latter being frequently filled to excess. In the case of pedal operated closing machines the operator obviously can, by slowly raising the container, hold the cover in such manner that it shall come exactly opposite the mandrel, but this method of working occupies too much time, and in large establishments it is necessary to employ automatic feeds, and with such feeds it is impossible to maintain the cover in place by hand, so that the latter, being free, is liable to become displaced while the container is being brought into position and even to become entirely separated therefrom.

The object of the present invention is to provide mechanical feeding apparatus adapted to always retain the cover rigorously in its proper position, even when the container is filled to excess, until the moment of closure, and to render impossible any displacement of the cover whatever may be the speed at which the container is brought into operative position relatively to the closing machine.

This apparatus is characterized essentially by the combination of: (a) double clamps comprising lower jaws for gripping the body of the container and upper jaws or retaining devices for maintaining the cover centrally of the container; these double clamps receiving, in addition to their opening and closing movement for gripping and releasing the container, a longitudinal movement of translation whereby to bring the containers successively to operative position relatively to the closing machine. (b) A pressing device mounted upon a vertically movable stem extending in axial alinement with the mandrel of the closing machine and received, when in its extreme upper position, in a recess in the mandrel; said pressing

device being actuated in such manner as (1) to bear upon the cover and thus cause the latter to completely engage with the container so long as the double clamp grips the body of the container, and retains the cover centrally thereof, and (2) to continue to bear lightly upon the cover during the ascending movement of the container until it comes into contact with the mandrel of the closing machine.

In the accompanying drawings, which illustrate an example of the present invention, Figure 1 shows the apparatus partly in front elevation and partly in vertical section, the parts being shown in the position they occupy at the end of the closing operation, the feeding device being in the open position. Fig. 2 is a side elevation of the apparatus. Fig. 3 is a transverse vertical section of the feeding device in its closed position at the moment when the container is about to be presented to the closing device. Figs. 4 and 5 show the feeding device in plan in its two extreme positions, the one open and the other closed. Figs. 6 to 9 are diagrammatic views showing the different phases of the feeding operation.

As will be seen in the drawing the present feed-system comprises two double clamps A, B each provided with two lower jaws a a^1 and two upper jaws b b^1 respectively integral therewith; the jaws a a^1 being so formed as to be capable of gripping the top of the container to be closed, while the jaws b b^1 serve simply to maintain the cover centrally on the container. These jaws receive at the requisite moments a closing and an opening movement relatively to one another, and a movement of translation upon the table c of the machine. This double movement may be produced by any suitable mechanism, for example by the following arrangement.

Each double jaw a b , a^1 b^1 is carried by a plate d d^1 resting on the table c , the two plates being jointed respectively to two arms e e^1 in one with two sleeves f f^1 capable of turning and sliding upon two fixed shafts g g^1 supported on the framework of the machine. The two sleeves are connected together by a connecting rod f^2 . The transverse displacement of the double jaws is produced by a single rod h which is actuated by a cam i fast on the driving shaft j , the vertical movement of this rod h being guided by a fixed sleeve k secured to the

frame of the machine. In order that transverse displacement of the double jaws may be transmitted notwithstanding the movement of translation of the latter, one of the sleeves f is provided with a small parallel shaft l which, when it participates in the movement of translation of the sleeve f slides in the head of the rod h . The two sleeves f f^1 are respectively operated by arms m m^1 which are connected by a pivot pin n attached by a rod o to a lever p which is mounted to turn on a movable axis q and actuated by a cam r keyed upon the driving shaft j .

The table c presents, in front of the mandrel s of the closing machine, an aperture c^1 for the passage of the head t upon which the container to be closed is supported, and which presents the cover to the action of the closing rollers. The vertical movement of the head t is produced by means of a cam u fast on the shaft j and acting upon the lower extremity of a vertical rod t^1 which supports the head t . The head t is furnished at its periphery with a flange serving to maintain the container in its exact position.

The table c has a crosspiece c^2 and the head t a corresponding recess whose height is equal to the vertical movement of the head, the object of this crosspiece c^2 being to furnish a supporting surface for the container at the moment when the latter is brought over the head t while the latter is at the bottom of its strike (see Fig. 3).

In order that the cover shall be held during the ascending movement of the container, the mandrel s is traversed by a vertical rod v carrying at its lower portion a small presser w which, when at the upper part of its movement is received in a recess in the lower face of the mandrel s (see Figs. 2 and 3). The presser w receives vertical movement determined in such manner as to press upon the cover of the container which has just been fed in, and to rise at the same time as this container; always maintaining in place the cover applied thereto. This vertical movement of the presser w is produced by a cam x keyed to an upper shaft y which receives its movement from the driving shaft j by any suitable means. The contact of the friction roller on the end of the rod v with the cam x is insured by means of a buffer spring; or the cam may be provided with a groove in which the roller may engage so as to move the rod v in both directions; or again, a spring may be employed to constantly depress the rod v , the cam x being so arranged as to raise the presser w as indicated above.

The container to be seized by the feeding device is placed by hand, or mechanically in a spring clip z from which it is taken by the clamp A.

The device having been brought to its

starting position (Figs. 2 and 4) operates as follows:—The jaws of the clamps A and B close (Fig. 6); the clamp A seizes the container C which is presented to it as is also the cover of the container; the clamp B being unoccupied at the commencement of the operation. The two clamps A and B receive a movement of translation in the direction of the arrow shown in Fig. 6 and come into the position shown in Figs. 5 and 7. In this movement the clamp A brings the container C to the initial position of the clamp B and the latter comes into position over the head t of the closing machine. The two clamps A and B thereupon open and are drawn back to their original position. At the commencement of the operation the working parts of the closing machine operate idly inasmuch as the clamp B has not had any container fed to it. The two clamps A and B returned to their initial position close again (Fig. 8) the clamp A seizes a fresh tin C¹ furnished with its cover, and the clamp B seizes the tin C previously fed forward by the clamp A. The two clamps A and B then receive, as has been previously stated, a movement of translation (Figs. 5 and 9) in which the clamp A deposits the tin C¹ at the initial position of the clamp B and the latter brings the tin C on to the crosspiece c^2 above the head t of the closing machine. The presser w then descends upon the cover of the container C (Fig. 3) and causes it to completely engage with the latter before the jaws of the clamp B open, so that the seating of the cover in or upon the container is accurately guided by the upper jaws b b^1 . The head t then rises, lifts the tin C and presents the upper edge thereof and of its cover to the action of the closing rollers, which come into operation. During the rising of the head t the presser w also rises, but continues to press lightly upon the cover. The container and its cover thus remain imprisoned between the head t and presser w so that all displacement of the cover is rendered impossible, which insures that the container and its cover are always presented in the requisite position to the mandrel s of the closing machine. The closure or seaming of the edge of the cover upon the edge of the container is thereupon effected in the ordinary manner, and when this has been done the head t descends and deposits the container completely closed and seamed upon the crosspiece c^2 of the table c of the machine. The container is finally thrust away by the front extremity of the jaws of the clamp B when the latter advances and brings another container over the head t . The same operations are repeated in succession. By means of this feeding arrangement with two clamps A, B, the operation of the machine proceeds without intermission, but it is to be understood that the

apparatus need not comprise more than a single clamp.

The invention is applicable to all closing machines.

5 The form and dimensions of the feeding clamps as well as of their actuating mechanism may be modified in accordance with requirements.

I claim—

10 1. In a container closing machine, in combination with closing mechanism, clamps arranged both to hold the container body and to center and hold its cover thereon, a presser arranged to press the cover against
15 the container body while held by the aforesaid clamps, and means for removing the container from said clamps to the closing mechanism while the presser continues to press upon the cover, substantially as and
20 for the purpose described.

2. In a container closing machine, in combination with closing mechanism, clamps arranged both to hold the container body and to center and hold its cover thereon, a
25 presser arranged to press the cover against the container body while held by the aforesaid clamps, means for opening and closing said clamps, a supporting head beneath said container, and means for raising said head
30 so as to remove the container to the closing mechanism while the presser continues to press upon the cover, substantially as and for the purpose described.

3. In a container closing machine, in combination with closing mechanism and a table,
35 clamps arranged both to hold the container body and to center and hold its cover thereon, means for opening and closing said clamps, a supporting head, means for moving said clamps over the table so as to transfer the container to the supporting head, a
40 presser arranged to press the cover against the container body while held by the aforesaid clamps and upon the supporting head,
45 and means for raising said head so as to remove the container to the closing mechanism while the presser continues to press upon the

cover, substantially as and for the purpose described.

4. In a container closing machine, in combination with closing mechanism and a table,
50 clamps adjacent a selected point of the table adapted to both hold the container body and to center and hold its cover thereon, a supporting head at another point of the table,
55 means for moving said clamps over the table so as to transfer the container to the supporting head, a presser arranged to press the cover against the container body while held by the aforesaid clamps and upon the
60 supporting head, means for raising said head so as to remove the container to the closing mechanism while the presser continues to press upon the cover, and means for opening the clamps and returning them
65 to their starting point, substantially as and for the purpose described.

5. In a container closing machine, in combination with closing mechanism and a table,
70 a series of linearly arranged sets of clamps each adapted to both hold a container body and to center and hold its cover thereon, means for moving said series longitudinally to and fro and for opening and closing the clamps so as to move a container from one
75 set of clamps to the next, a supporting head at one limiting position of an end clamp of the series, a presser arranged to press the cover against the container body while held by a clamp upon the supporting head, and
80 means for raising said head so as to remove the container to the closing mechanism while the presser continues to press upon the cover, substantially as and for the purpose described.
85

The foregoing specification of my mechanical feeding apparatus for machines for closing metal containers signed by me this 10th day of July 1908.

ARTHUR WILZIN.

Witnesses:

H. C. COXE,
MAURICE H. PIGNET.