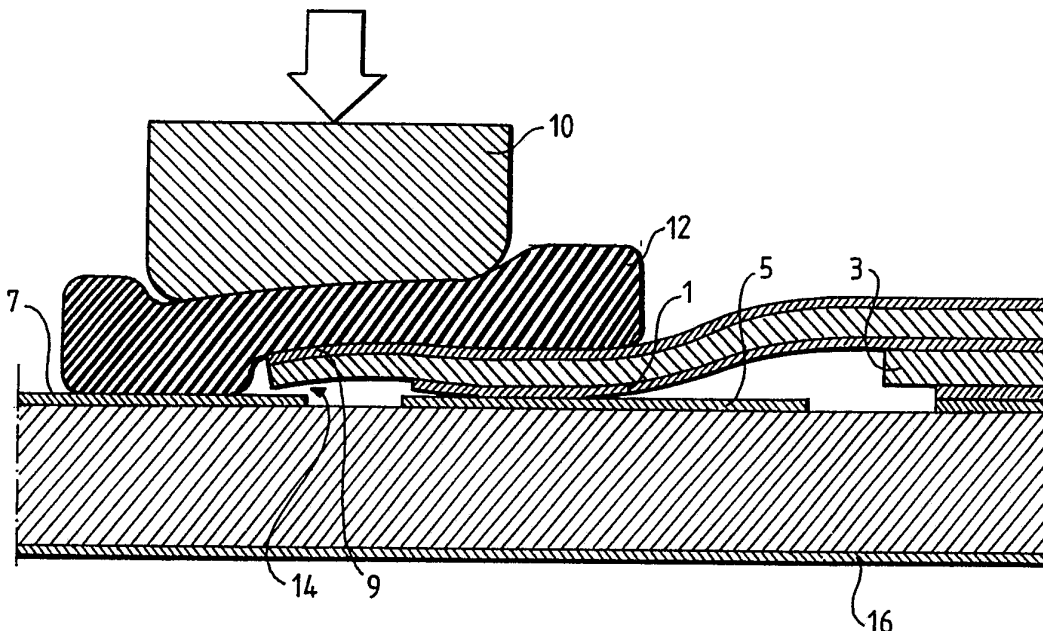

INTERNATIONAL APPLICATION PUBLISHED UNDER THE PATENT COOPERATION TREATY (PCT)

(51) International Patent Classification ⁵ : H01R 13/648	A1	(11) International Publication Number: WO 92/22944 (43) International Publication Date: 23 December 1992 (23.12.92)
--	-----------	---

(21) International Application Number: PCT/SE92/00409**(22) International Filing Date:** 12 June 1992 (12.06.92)**(30) Priority data:**
9101836-6 14 June 1991 (14.06.91) SE**(71) Applicant:** TELEFONAKTIEBOLAGET L M ERICSSON [SE/SE]; S-126 25 Stockholm (SE).**(72) Inventors:** LEEB, Karl-Erik ; Lillebo, S-130 40 Djurhamn (SE). HOLMBERG, Ulf, Ingvar ; Flygarvägen 257, S-175 63 Järfälla (SE).**(74) Agents:** LINDÉN, Stefan et al.; Bergensträhle & Lindvall AB, Box 17704, S-118 93 Stockholm (SE).**(81) Designated States:** AT (European patent), BE (European patent), CH (European patent), DE (European patent), DK (European patent), ES (European patent), FR (European patent), GB (European patent), GR (European patent), IT (European patent), JP, LU (European patent), MC (European patent), NL (European patent), SE (European patent).**Published***With international search report.***(54) Title:** A DEVICE FOR CONTACTING SHIELDED CONDUCTORS**(57) Abstract**

In a device for contacting shielded conductors, surrounded by shield and ground planes (9, 8, 7, 16), a clamping means (10) is disposed to press contact means (1, 5) connected to the conductors against each other as well as shield and ground planes (7, 8) which face each other and surround the contact means (1, 5). A pad (12) of an electrically conducting, elastic material is arranged between the clamping means and one of the contact means (1). The pad (10) covers the contact area between the contact means (1, 5) and is in contact with the surrounding ground planes (9, 7) to form an electrically closed enclosure of the contact means (1, 5).

FOR THE PURPOSES OF INFORMATION ONLY

Codes used to identify States party to the PCT on the front pages of pamphlets publishing international applications under the PCT.

AT	Austria	FI	Finland	ML	Mali
AU	Australia	FR	France	MN	Mongolia
BB	Barbados	GA	Gabon	MR	Mauritania
BE	Belgium	GB	United Kingdom	MW	Malawi
BF	Burkina Faso	GN	Guinea	NI	Netherlands
BG	Bulgaria	GR	Greece	NO	Norway
BJ	Benin	HU	Hungary	PL	Poland
BR	Brazil	IE	Ireland	RO	Romania
CA	Canada	IT	Italy	RU	Russian Federation
CF	Central African Republic	JP	Japan	SD	Sudan
CG	Congo	KP	Democratic People's Republic of Korea	SE	Sweden
CH	Switzerland	KR	Republic of Korea	SN	Senegal
CI	Côte d'Ivoire	LI	Liechtenstein	SU	Soviet Union
CM	Cameroon	LK	Sri Lanka	TD	Chad
CS	Czechoslovakia	LU	Luxembourg	TG	Togo
DE	Germany	MC	Monaco	US	United States of America
DK	Denmark	MG	Madagascar		
ES	Spain				

A device for contacting shielded conductorsField of the invention

The present invention is related to a device for contacting shielded conductors surrounded by shield and ground planes.

Background of the invention

In electronic equipment and circuits for high frequencies and data signals having short transient times there is a need of conducting these signals in shielded, impedance matched conductors and to connect the conductors in the equipment and the circuit board with electrically conducting enclosures which short circuit electromagnetic radiation. Even small "slots" may transmit radiation which may interfere with other equipment and other circuits.

Prior art

Conventional connectors for such applications have weaknesses in that they either are not closed at all connecting surfaces or that they are difficult to mount. This is especially true if the circuit is intended for surface mounted components. In addition prior connectors for high frequency transmission are costly which is a further disadvantage. A prior contact device of this kind could be found for instance in DE A 26 49 374.

Summary of the invention

The purpose of the present invention is to provide a device for contacting shielded conductors wherein the disadvantages discussed above in prior solutions are eliminated.

This purpose is achieved in a device of the kind as described above having the characteristics set out in claim 1.

Thus a device is provided for contacting two shielded conductors, each one of which is embedded in or located on a dielectric sheet or laminate. A shield and ground plane is located at least on one of the sides of each one of said conductors. A clamping or pressing means is arranged to press contact means against each other, as well as two of said shield and ground planes. The contact means have at least one substantially flat surface and one of the contact means is connected to or comprised in each one of said two conductors. Said two shield and ground planes surround the contact means, are substantially coplanar with the flat surfaces of the contact means and face each other. A pad of an electrically conducting,

elastic material is arranged between said clamping or pressing means and one of the contact means in order to cover at least a portion of the contact area between the contact means. The pad is in contact with at least two of the shield and ground planes in order to form an electrically closed enclosure of the contact means.

According to an advantageous embodiment at least one contact means is made from an exposed portion of a stripline conductor, which is arranged between two dielectric isolating sheets, which on the outside are covered with conductive layers such as laminated metal foils, a recess being made in one plastics sheet and the associated foil in order to expose said contact means.

In an important application of the device one of the contact means is arranged on a circuit pattern board.

According to another advantageous embodiment the pad is made from elastic, conducting rubber, such as silicon rubber having coal as a filling agent.

Short description of the figures

An embodiment of the device according to the invention will now be described by way of example in more detail and with reference to the accompanying drawings, in which

Fig. 1 shows a laminate having a stripline conductor, as seen obliquely from the bottom, and a circuit pattern board, as seen obliquely from the top,

Fig. 2 shows in a cross sectional view the laminate brought into contact with a circuit pattern board, as seen from the end of the conductor,

Fig. 3 shows the contact area in a cross-sectional view and in a larger scale as seen in a direction perpendicular to that of Fig. 2, that is in the longitudinal direction of the conductor,

Figs. 4 to 7 illustrate some possible ways of arranging a pressing force.

Description of the preferred embodiment

In the figures the thicknesses illustrated of the substrates and the foils are highly exaggerated in order to clarify the invention.

In Fig. 1 a laminate is shown with a stripline conductor, which has the shape of a conductive band and is arranged

embedded between two laminated, thin dielectric plastics sheets 2, 3 to form a first laminate, illustrated in the top part of the Figure. On the exterior sides of the plastics sheets conductive layers in the shape of metal foils 8, 9 are applied in order to form shield and ground planes. Also the common edges of the dielectric sheets 2,3 may be sealed by a conductive layer, as is illustrated in the Figure.

In one 3 of the dielectric sheets 2, 3 and the foil 8 covering this sheet 3 a substantially rectangular aperture or hole is arranged to form a recess 4 in the first laminate, this hole exposing a portion of the conductor. This exposed portion of the conductor forms one contact means 1 with a substantially flat outer surface and it has the shape of a thin band extending from one of the sides of the rectangular recess 4, is located on the inner side of the other dielectric sheet 2 and is immediately surrounded on some of its sides, in Figure 1 on three sides, by isolating inner surface portions of the other dielectric sheet 2. In Fig. 1 the recess 4 extends from a free edge of the first laminate, this edge also being a common edge of the dielectric sheets 2, 3.

Below this contact means 1 in Fig. 1 a corresponding contact means 5 having the shape of a thin band with a substantially flat surface is arranged on the top surface or side of a multilayer circuit pattern board forming a second laminate, this contact means 5 for instance being a selected etched portion of the conductive pattern on top of the circuit board. The contact means 5 may also be connected to a conductor, for instance located inside the circuit pattern board, through a metallized or through-coated hole 6 which extends between a top ground plane 7 and a lower ground plane 16 of the circuit pattern board.

On the surface of the circuit pattern board where the contact means 5 is located there is also a shield and ground plane 7 surrounding laterally completely the contact means 5, this shield and ground plane for instance being another portion of the same conductive pattern as the contact means 5 of the circuit pattern board, and arranged to have its surface in essentially the same geometrical plane as the surface of the second contact means 5. On the other side of the circuit pattern

board another conductive layer 16 is located and forms another shield and ground plane.

A contact between the contact means 1, 5 is established by applying the laminated first unit and the circuit pattern board to each other, that is positioning them at each other with their large sides in engagement with each other, and by pressing the contact means 1, 5 against each other by applying a force according to the arrow 17 in Fig. 2 on top of the first laminated unit at a location opposite to the recess 4 or the first contact means 1. The material of laminated unit, that is of the plastics sheet 2, which is left in the recess 4 will then be bent down towards the circuit board in the same time as the ground planes 7, 8, which already are engaged with each other and are located on the circuit pattern board and the laminated unit respectively, are pressed against each other in such a way that the contact area will be tightly shielded, but only in the case (not shown) where the recess 4 is located at an inner portion of the laminated unit and not extending to any of its edges. However, in the illustrated case, where the recess 4 extends from an edge of the first laminated unit, an unshielded narrow portion will be left along the common edge of the recess 4 and the laminated unit in the thickness of the dielectric sheet 3, in which the recess 4 is made.

The press force is obtained by a suitable pressing means 10, as is illustrated in Fig. 3.

In order to shield also the said narrow portion at the outer edge of the recess 4, a pad 12 is arranged between the pressing means 10 and the laminated unit, the pad 12 being made of an electrically conducting, elastic material, such as coal filled silicon rubber. The pad is deformed due to the pressing force and will conform to the base material, whereby said narrow portion or slit at 14 in Fig. 3, due to the aperture 4 in the plastics sheet 3, will be closed by the pad 12, which thus will cover the contact area and ensure a completely closed shield around the contact means 1, 5 in contact with the surrounding shield and ground planes 7, 9. The elastic pad 12 also distributes the pressure in such a way that a smooth engagement both between the contact means 1, 5 and the surrounding metal foils enclosing the contact means at three sides thereof is

obtained. A condition for this shielding effect of the elastic pad 12 is that the edge of the top laminate where the recess 4 is located, is positioned at a distance from the edges of the lower laminate.

In the illustrated case where the first laminate with the stripline conductor has a relatively small width, the whole exposed edge, from which the recess 4 extends, may be shielded by the elastic conductive pad 10. Generally, this edge of the first laminate may also be coated with a conductive layer, as is illustrated for the other edges in Fig. 1. Then only the common edge of the first laminate and the recess has to be sealed by the elastic pad 10.

As is illustrated in Fig. 4 in a cross sectional view the press force may be obtained by two bolts 19 extending through holes in both laminates and tightened by nuts 20, the bolts 19 also acting on a stiff pressing element 21 with holes for the bolts 19. The pressing element 21 may have a suitably shaped pressing surface which acts on the top side of the elastic pad 10 to press it into the desired contact with the ground planes 9 and 7 and also to press the contact means 1, 5 against each other. Another stiff element 22 may be arranged at the bottom of the circuit board, opposite to the second contact means 5, to eliminate bending of the circuit board.

The bolts may also pass through the contact means 1, 5 and this case is illustrated in Fig. 5. A bolt 22 made from an isolating material passes through holes in the two laminates, in the elastic pad 10 and in a stiff element 23 arranged and acting in a similar way as the stiff element 21 of Fig. 4. The hole in the circuit board laminate may be a plated or metallized hole used for connection of the contact means 5 and an inner conductor 24 of the circuit board. An isolating nut 25 is threadedly engaged with the bolt 22 and a washer 26 may be arranged under the nut 25.

With a conductive bolt made from metal a shielding even of the bottom of the circuit board may be obtained, as is illustrated in Fig. 6. Thus a metal bolt 27 cooperating with a metal nut 28 is used and gives a pressing force in the same way as the bolt 22 of Fig. 6. A stiff element 29, through which the bolt 27 passes, has the shape of a large diameter washer. The

bolt 27 should not contact the metallized hole in the circuit board and therefor an isolating sleeve 30 having a collar 31 is placed inside the metallized hole. Thus this hole in the contact means 5 in circuit pattern board may have a little larger diameter than the hole through the top laminate. Also the contact means 1 of the top laminate should not extend up to this hole so that an isolating marginal portion 32 is exposed in the top dielectric sheet 2 adjacent to the hole.

In order to shield the area at the bottom surface around the through-hole in the circuit pattern board a conductive cap 33 having a hole in the centre thereof, through which the bolt 27 passes, is located at the bottom surface and has its outer portions pressed against the ground layer 16. Around the hole in the circuit board this ground layer 16 is, as is conventional, removed in order to be isolated from the metallization in the through-hole. The conductive cap 33 has preferably a concavely shaped surface directed to said ground plane 16.

The screw applying the pressing force may also pass the contact means 1, 5 through ordinary holes not having a metallization. This case is illustrated in Fig. 7 where the first contact means 1 has a circular or annular shape with a hole 34 located at its centre. The contact means 1 may in this case, for a conductive bolt, not reach the edge of the hole and thus an annular flat region 35 is obtained on the inner surface of the dielectric sheet 2. In this way the contact means 1 is isolated from the screw intended to pass through the hole 34. The contact means 1 is connected to a conductor through a connecting bridge 36.

In the lower laminate the contact means 5 has an elongated shape surrounding at one end a hole 37, through which the clamping screw is intended to pass. Here also there may be an annular area immediately surrounding the hole 37 and not covered by the contact means 5. At the other end of the contact means a through-metallized or plated hole 39 is located which thus connects the contact means 5 with signal conductors inside the circuit board. The contact means 5 is surrounded at all its lateral sides, that is in a geometrical plane passing through the surface of the contact means 5, by the ground plane 7. Likewise, as above the shape and location of the inner edge of

this surrounding ground plane 7 is adapted to fit to the recess 4 in the top laminate. The contact means 5 may in this case be part of the metallization deposited for the through-plating of the electrically connecting hole 39, this implying the top surface of the contact means 5 being essentially flat.

Claims

1. A device for contacting shielded conductors which are surrounded by shield and ground planes, **characterized in that** a clamping or pressing means (10) is arranged to press contact means (1, 5) connected to or comprised in the conductors against each other, as well as shield and ground planes (7, 8), which surround the contact means (1, 5) and face each other.

2. A device according to claim 1, **characterized in that** a pad (12) of an electrically conducting, elastic material is arranged between said clamping or pressing means (10) and one (1) of the contact means, said pad (12) covering the contact area between the contact means (1, 5) and being in contact with at least two of the surrounding shield and ground planes in order to form an electrically closed enclosure of the contact means (1, 5).

3. A device according to one of claims 1 - 2, **characterized in that** at least one of the contact means is made from an exposed portion of the conductor (1).

4. A device according to one of claims 1 - 3, **characterized in that** at least one of said conductors is arranged between two dielectric sheets (2, 3), which at the outside are covered by conductive layers (9, 8) such as laminated metal foils, a recess (4) being arranged in one (3) of said dielectric sheets and the conductive layer (8) covering this dielectric sheet (3) in order to expose a portion of said conductor to form said contact means (1).

5. A device according to claim 4, **characterized in that** said recess (4) extends from an edge of said one dielectric sheet (3).

6. A device according to claim 4, **characterized in that** said edge is located above an inner portion of the shield and ground plane (7) which surround the contact means (5) which is not located on the dielectric sheets (2, 3), this inner portion being located at a distance from the edges of this shield and ground plane (7).

7. A device according to one of claims 1 - 6, **characterized in that** the pad (12) is made from an electrically conducting rubber, such as coal filled silicon rubber.

8. A device for contacting two shielded conductors, each one of which is embedded in or located on a dielectric sheet or

laminate, a shield and ground plane being located at least on one of the sides of each one of said conductors, **characterized in** that a clamping or pressing means (10) is arranged to press contact means (1, 5), which have at least one substantially flat surface, one of said contact means (1, 5) being connected to or comprised in each one of said two conductors, against each other, as well as two of said shield and ground planes (7, 8), which surround the contact means (1, 5), are substantially coplanar with the flat surfaces of the contact means (1, 5) and face each other.

10. A device according to claim 9, **characterized in** that at least one of said conductors is arranged between two dielectric sheets (2, 3), which at the outside are covered by conductive layers (9, 8), a recess (4) being arranged in one (3) of said dielectric sheets and the conductive layer (8) covering this dielectric sheet (3) in order to expose a portion of said conductor to form said contact means (1).

11. A device according to one of claims 9 - 10, **characterized in** that one (1) of said contact means is located near an edge of its dielectric sheet or laminate and that a pad (12) of an electrically conducting, elastic material is arranged between said clamping or pressing means (10) and one (1) of the contact means, said pad (12) covering at least a portion of the contact area between the contact means (1, 5) and being in contact with at least two (7, 9) of the shield and ground planes in order to form an electrically closed enclosure of the contact means (1, 5).

12. A device according to claim 11, **characterized in** that said at least two shield and ground planes includes one of the shield and ground planes, which surround the contact means (1, 5), and another shield and ground plane not surrounding the contact means and located on the dielectric sheet or laminate, on which said surrounding shield and ground plane is not located.

13. A device according to claim 10 and 11 or 12, **characterized in** that said recess (4) extends from a common edge of said two dielectric sheets (2, 3) and that said pad (12) is arranged to cover said common edge.

14. A device according to claim 13, **characterized in** that

said edge is located above an inner portion of the shield and ground plane (7) which surround the contact means (5) which is not located on the dielectric sheets (2, 3), this inner portion being located at a distance from the edges of this shield and ground plane (7).

15. A device according to one of claims 9 - 14, **characterized in** that at least one of said conductors is arranged on top of a circuit pattern board, one portion of this conductor being one (5) of the contact means, a conductive layer (16) being located on the bottom of said circuit pattern board to form a shield and ground plane and another conductive layer (7) being located on the same side as said conductor and contact means (5) at least partly surrounding the conductor and contact means (5) to form another shield and ground plane.

16. A device comprising two laminates having conductors embedded in or located on dielectric sheets or laminates, comprising shield and ground planes, a shield and ground plane being located at least on one of the sides of each one of said conductors, **characterized in** a clamping or pressing means (10) arranged to press contact means (1, 5), one of said contact means (1, 5) being located in each one of said laminates and connected to or comprised in each one of said two conductors, each of which contact means (1, 5) has at least one substantially flat surface exposed at one side of the laminate, where it is located, against each other, as well as two of said shield and ground planes (7, 8), which surround the contact means (1, 5), are substantially coplanar with the flat surfaces of the contact means (1, 5) and face each other.

17. A device according to claim 16, **characterized in** that one (1) of said contact means is located near an edge of its dielectric sheet or laminate and that a pad (12) of an electrically conducting, elastic material is arranged between said clamping or pressing means (10) and one (1) of the contact means, said pad (12) being arranged to cover at least a portion of the contact area obtained by the clamped or pressing means (10) between the contact means (1, 5) and to contact at least two (7, 9) of the shield and ground planes in order to form an electrically closed enclosure of the contact means (1, 5).

18. A device according to one of claims 16 - 17,

characterized in that at least one of said conductors is arranged between two dielectric sheets (2, 3) in one of the laminates, which sheets (2, 3) at the outside of this laminate are covered by conductive layers (9, 8) forming shield and ground planes, a recess (4) being arranged in one (3) of said dielectric sheets and the conductive layer (8) covering this dielectric sheet (3) in order to expose a portion of said conductor to form the contact means (1) of this laminate.

19. A device according to claim 18, **characterized in** that said recess (4) extends from a common edge of said two dielectric sheets (2, 3) and that said pad (12) is arranged to cover at least said common edge.

20. A device according to one of claims 16 - 18, **characterized in** that at least one of the laminates is a circuit pattern board and that one of said conductors is arranged on top of this circuit pattern board, one portion of this conductor being one (5) of the contact means, and that a conductive layer (16) is located on the bottom of said circuit pattern board to form a shield and ground plane and another conductive layer (7) is located on the same side as said conductor and contact means (5) at least partly surrounding the conductor and contact means (5) to form another shield and ground plane.

21. A device according to one of the preceding claims, **characterized in** that the pressing or clamping means (10) comprises at least one tightening element (19, 20) passing through regions adjacent to but at some distance from the contact means (1, 5).

22. A device according to one of the preceding claims, **characterized in** that the pressing or clamping means (10) comprises at least one tightening element (22, 25; 27, 28) passing through the contact means (1, 5).

23. A device according to claim 22, **characterized in** that the tightening element (22, 25) is made from an isolating material.

24. A device according to one of claims 21 - 23, **characterized in** that the wall of a hole, through which the tightening element (19, 20; 22, 25; 27, 28) passes, is at least partly metallized in order to connect conductors located on different levels with each other.

25. A device according to one of claims 21 - 24,

characterized in that the wall of a hole, through which the tightening element (27, 28) passes, is at least partly metallized in order to connect conductors located on different levels with each other and that this hole, at the end not located in the contact means, is isolated by an area on the surface of an underlying dielectric sheet and that this area is surrounded by a shield and ground plane (16) and that a conductive cap (33) is located to cover said end and the surrounding area and to be in contact with the surrounding shield and ground plane (16) along its border.

26. A device according to claim 25, **characterized in** that the tightening element (27, 28) also passes through the conductive cap (33) to press it against said surrounding shield and ground plane (16).

27. A device according to one of claims 25 - 26, **characterized in** that the tightening element (27, 28) is made from a conductive material contacting the conductive cap.

28. A device according to one of claims 21 - 27, **characterized in** that the tightening element ((19, 20; 22, 25; 27, 28) is at least partly surrounded by an isolating sleeve (30).

29. A device comprising a first and second laminate, each having conductors embedded in or located on dielectric sheets and comprising a shield and ground plane (9, 16) on an outer side thereof, **characterized in**

contact means (1, 5) on each one of said laminates, the contact means (1, 5) having at least one substantially flat surface, one of said contact means (1, 5) being connected to or comprised in each one of said two conductors and located on each one of said laminates,

a first one (1) of said contact means being located in a recess (4) in the surface of the first laminate and extending to an edge of the first laminate,

a second one (5) of said contact means being located on a surface of the second laminate and surrounded at least partially by a shield and ground plane (7) having a surface substantially in the same geometrical plane as the surface of the second contact means (5),

the laminates being located in contact with each other with

the contact means (1, 5) facing each other, the common edge of the first laminate and the recess (4) over its whole length being positioned above said shield and ground plane (7) surrounding the second contact means (5),

a clamping or pressing means (10) being arranged to press the contact means (1, 5) against each other as well as said common edge and said surrounding shield and ground (7),

that a pad (12) of an electrically conducting, elastic material is arranged between said clamping or pressing means (10) and the first contact means (1), said pad (12) covering at least a portion of the contact area between the contact means (1, 5) and covering said common edge and being in contact with the outer shield and ground plane (9) on the first laminate and the surrounding shield and ground plane (7) on the second laminate in order to form an electrically closed enclosure of the contact means (1, 5).

30. A device according to claim 29, **characterized in** that said surrounding shield and ground plane (7) surrounds the second contact means (5) completely, that is on all sides in said geometrical plane.

31. A device according to one claims 29 - 30, **characterized in** that the edge of the first laminate, of which said common edge is a part, is shielded by a conductive layer.

32. A device according to one of claims 29 - 31, **characterized in** a shield and ground plane (8), which is located on an inner side of the first laminate and pressed against the surrounding shield and ground plane (7) on the second laminate.

33. A device according to claim 32, **characterized in** that the shield and ground plane located on the inner side of the first laminate surrounds the recess (4).

34. A device according to one of claims 29 - 33, **characterized in** that the second laminate comprises a circuit pattern board, having conductors on an inner side thereof, one portion of such a conductor being one (5) of the contact means.

35. A device according to one of claims 29 - 34, **characterized in** that the pressing or clamping means (10) comprises at least one tightening element (19, 20) passing through the two laminates adjacent to but at some distance from the contact means (1, 5).

36. A device according to one of claims 29 - 34, **characterized in** that the pressing or clamping means (10) comprises at least one tightening element (22, 25; 27, 28) passing through the contact means (1, 5) and the two laminates.

37. A device according to claim 36, **characterized in** that the tightening element (22, 25) is made from an isolating material.

38. A device according to one of claims 35 - 37, **characterized in** that the wall of a hole in one of the laminates, through which the tightening element (19, 20; 22, 25; 27, 28) passes, is at least partly metallized in order to connect conductors located on different levels in or on the laminate with each other.

39. A device according to one of claims 35 - 37, **characterized in** that the wall of a hole in the second laminate, through which the tightening element (27, 28) passes, is at least partly metallized in order to connect conductors located on different levels in the second laminate with each other and that this hole, at an end not located in the contact means, is isolated by an area on the surface of an underlying dielectric sheet and that this area is surrounded by a shield and ground plane (16) and that a conductive cap (33) is located to cover said end and the surrounding area and to contact the surrounding shield and ground plane (16) along its border.

40. A device according to claim 39, **characterized in** that the tightening element (27, 28) also passes through the conductive cap (33) to press it against said surrounding shield and ground plane (16).

41. A device according to one of claims 30 - 40, **characterized in** that the tightening element (27, 28) is made from a conductive material contacting the conductive cap.

42. A device according to one of claims 35 - 41, **characterized in** that the tightening element ((19, 20; 22, 25; 27, 28) is at least partly surrounded by an isolating sleeve (30).

Fig. 1

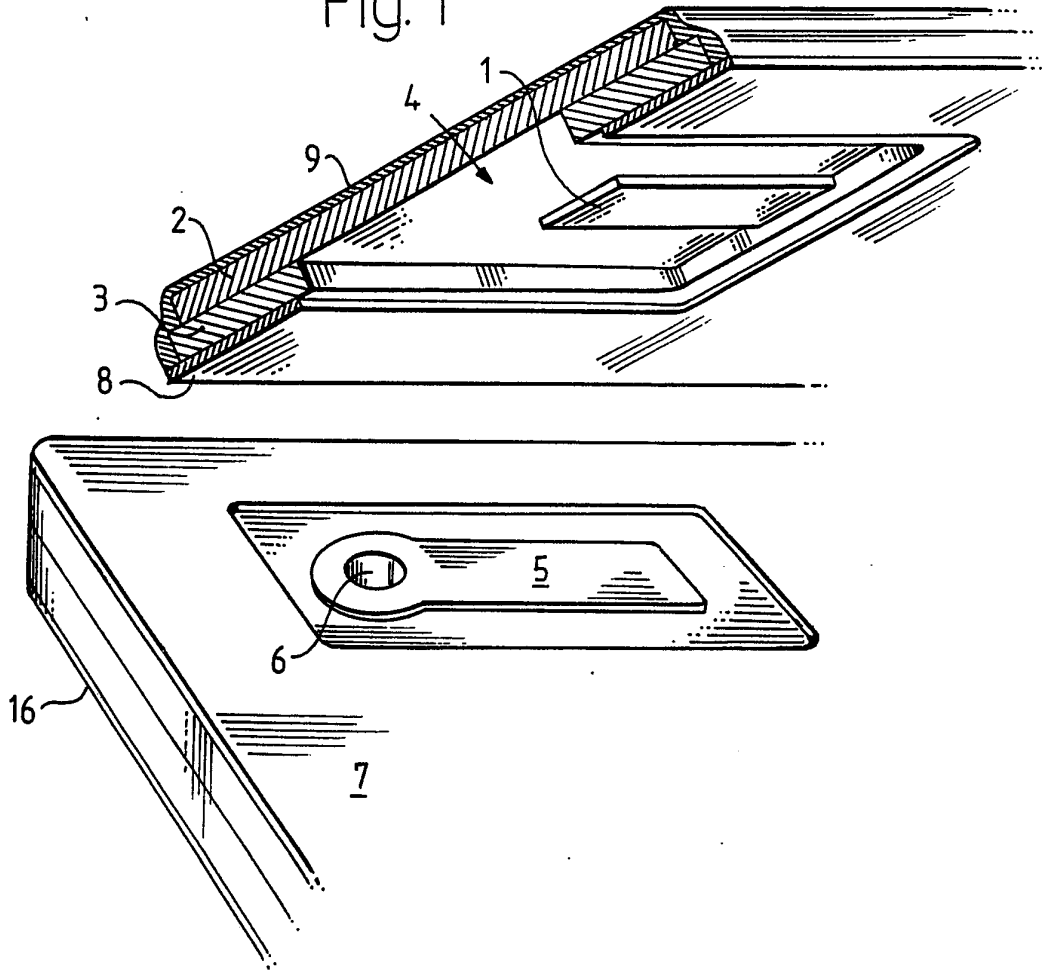

Fig. 2

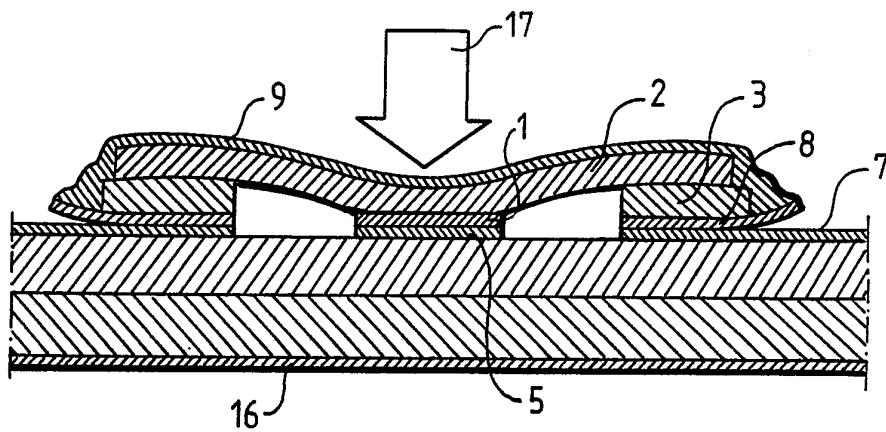

Fig. 3

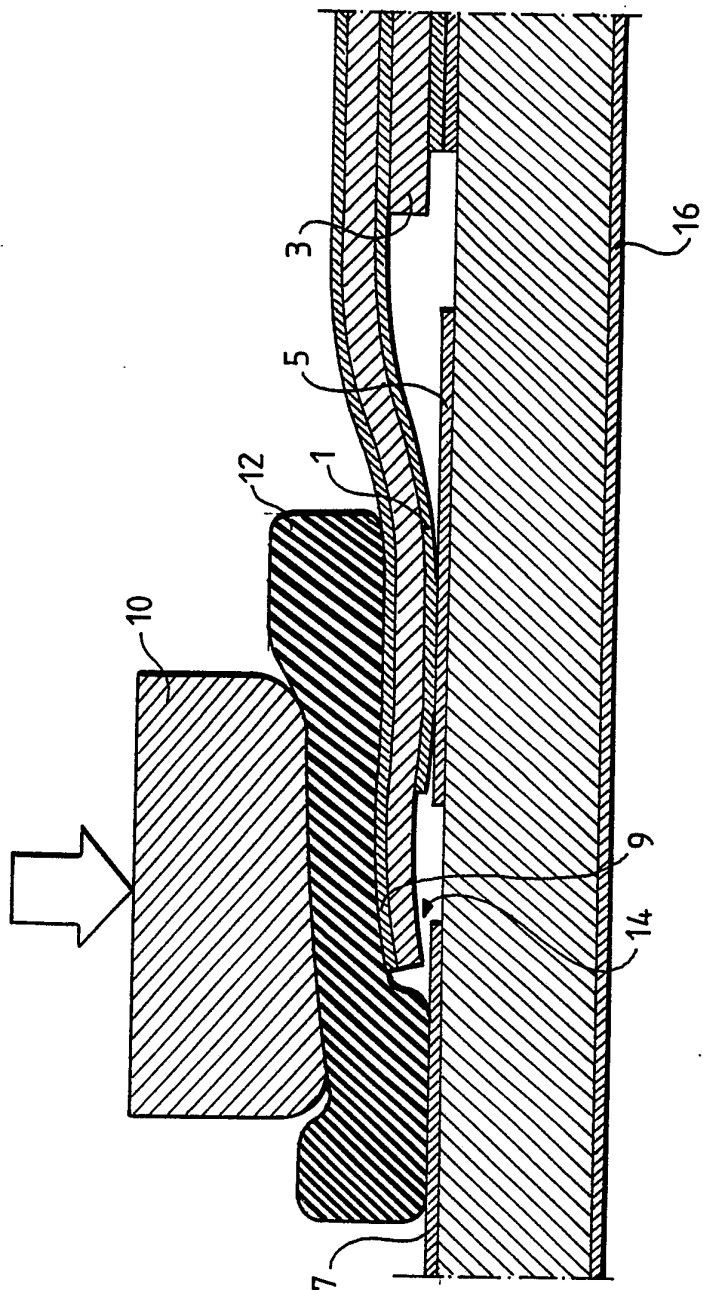

Fig. 4

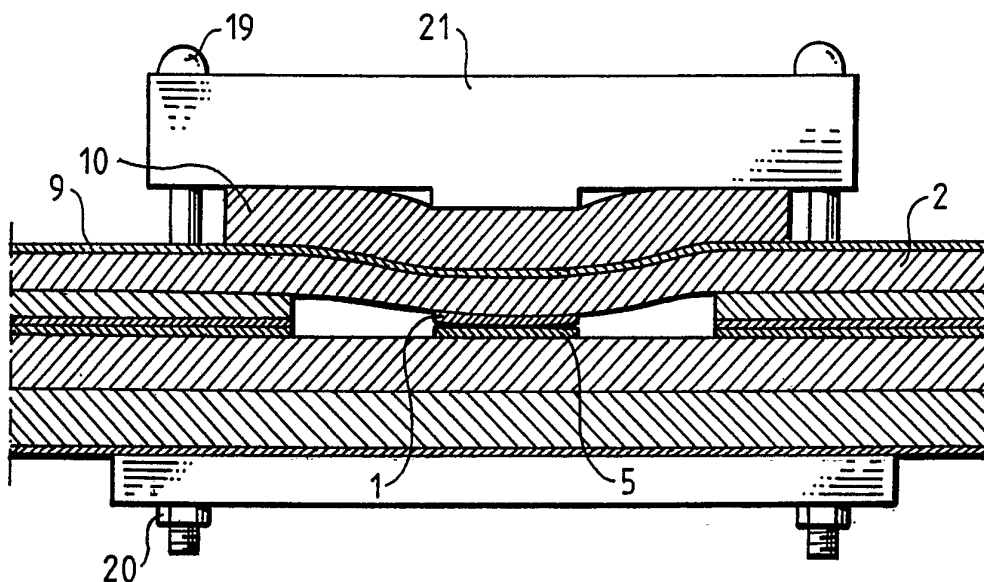

Fig. 5

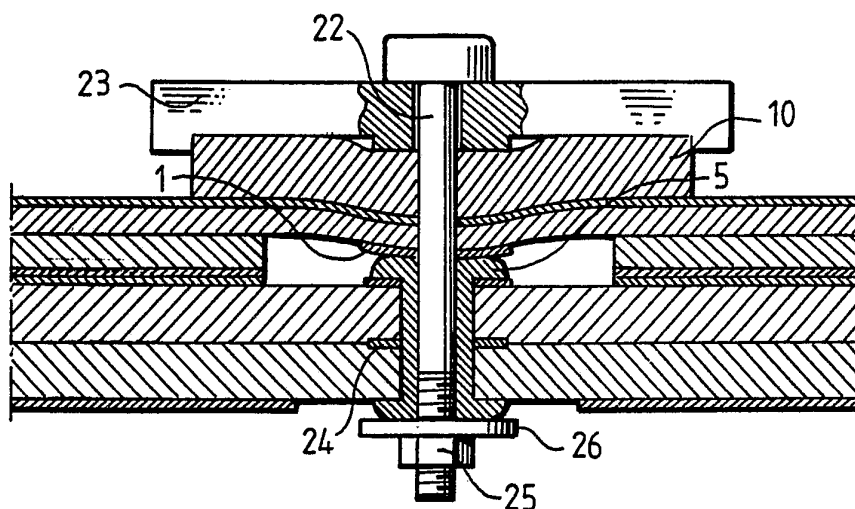

Fig. 6

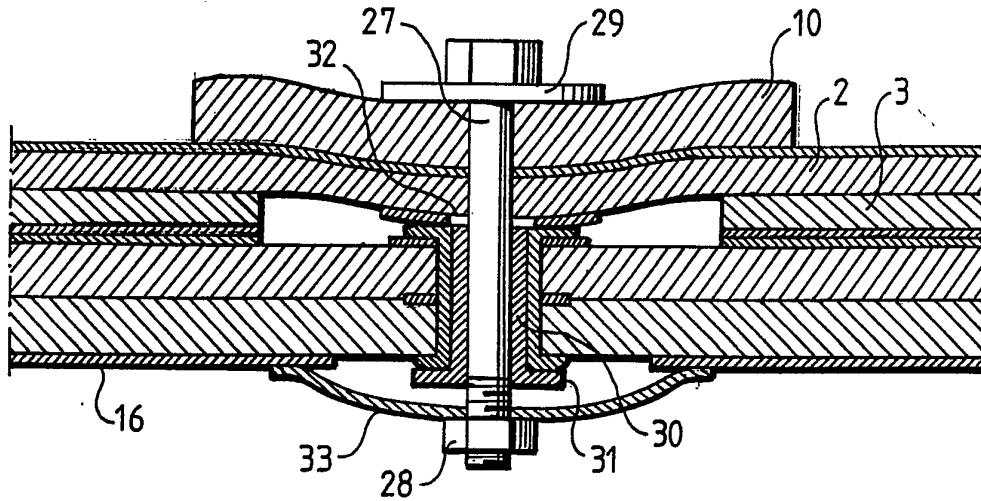
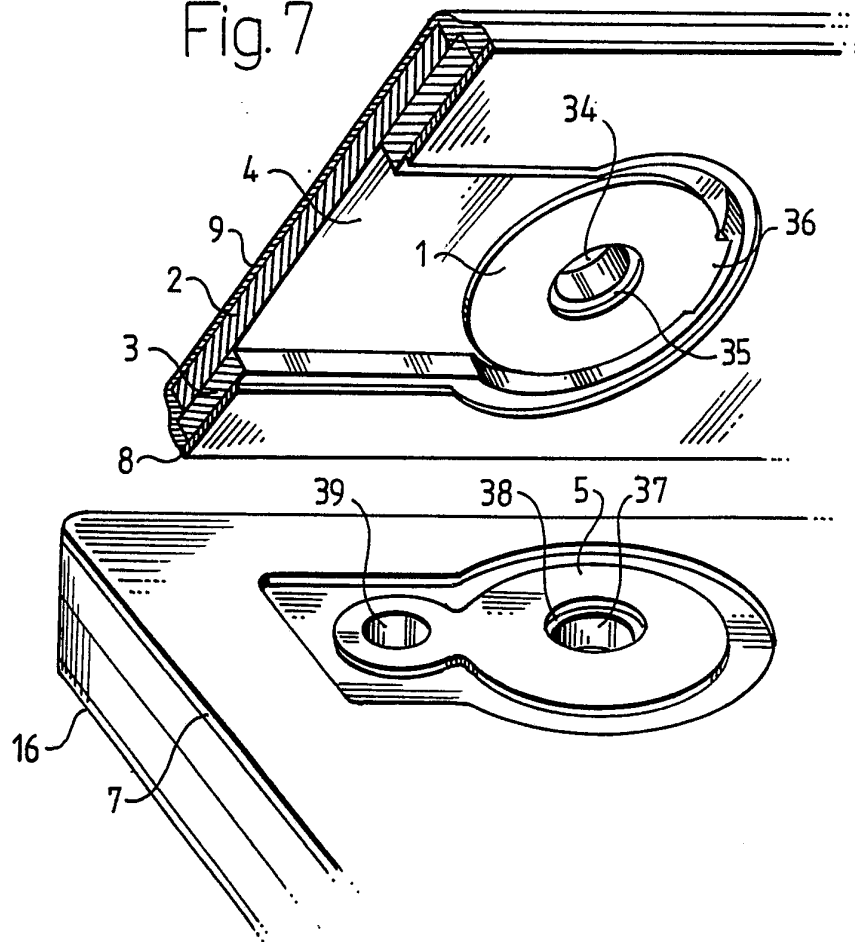

Fig. 7



INTERNATIONAL SEARCH REPORT

International Application No **PCT/SE 92/00409**

I. CLASSIFICATION OF SUBJECT MATTER (if several classification symbols apply, indicate all) ⁶		
According to International Patent Classification (IPC) or to both National Classification and IPC		
IPC5: H 01 R 13/648		
II. FIELDS SEARCHED		
Minimum Documentation Searched ⁷		
Classification System	Classification Symbols	
IPC5	H 01 R	
Documentation Searched other than Minimum Documentation to the extent that such Documents are Included in Fields Searched ⁸		
SE,DK,FI,NO classes as above		
III. DOCUMENTS CONSIDERED TO BE RELEVANT⁹		
Category *	Citation of Document, ¹¹ with indication, where appropriate, of the relevant passages ¹²	Relevant to Claim No. ¹³
X	US, A, 4116516 (WENDELL L. GRIFFIN) 26 September 1978, see column 3, line 10 - column 5, line 24	1,3-5,8, 16
A	--	29
X	US, A, 4458967 (WILLIAM A. KING ET AL) 10 July 1984, see column 2, line 54 - column 5, line 20	1
X	US, A, 4639053 (MANFRED REICHARDT ET AL) 27 January 1987, see column 4, line 16 - column 7, line 33	1
A	US, A, 4747785 (ARTHUR ROBERTS ET AL) 31 May 1988, see column 6, line 4 - line 23	2,7

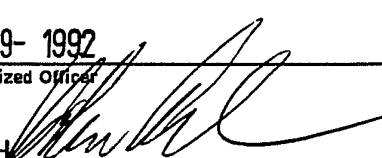
<p>* Special categories of cited documents: ¹⁰</p> <p>"A" document defining the general state of the art which is not considered to be of particular relevance</p> <p>"E" earlier document but published on or after the international filing date</p> <p>"L" document which may throw doubts on priority claim(s) or which is cited to establish the publication date of another citation or other special reason (as specified)</p> <p>"O" document referring to an oral disclosure, use, exhibition or other means</p> <p>"P" document published prior to the international filing date but later than the priority date claimed</p> <p>"T" later document published after the international filing date or priority date and not in conflict with the application but cited to understand the principle or theory underlying the invention</p> <p>"X" document of particular relevance, the claimed invention cannot be considered novel or cannot be considered to involve an inventive step</p> <p>"Y" document of particular relevance, the claimed invention cannot be considered to involve an inventive step when the document is combined with one or more other such documents, such combination being obvious to a person skilled in the art.</p> <p>"&" document member of the same patent family</p>		
IV. CERTIFICATION		
Date of the Actual Completion of the International Search	Date of Mailing of this International Search Report	
22nd September 1992	25 -09- 1992	
International Searching Authority	Signature of Authorized Officer	
SWEDISH PATENT OFFICE	HÅKAN SANDH 	

**ANNEX TO THE INTERNATIONAL SEARCH REPORT
ON INTERNATIONAL PATENT APPLICATION NO.PCT/SE 92/00409**

This annex lists the patent family members relating to the patent documents cited in the above-mentioned international search report. The members are as contained in the Swedish Patent Office EDP file on **28/08/92**. The Swedish Patent Office is in no way liable for these particulars which are merely given for the purpose of information.

Patent document cited in search report	Publication date	Patent family member(s)	Publication date
US-A- 4116516	78-09-26	CA-A- 1093169	81-01-06
US-A- 4458967	84-07-10	CA-A- 1193684	85-09-17
US-A- 4639053	87-01-27	DE-C- 3441818	86-02-20
		EP-A- 0182125	86-05-28
		JP-A- 61126782	86-06-14
US-A- 4747785	88-05-31	NONE	