



INTERNATIONAL APPLICATION PUBLISHED UNDER THE PATENT COOPERATION TREATY (PCT)

|  |                  |   |
|--|------------------|---|
| <p>(51) International Patent Classification <sup>6</sup> :<br/><b>H04Q 7/38</b></p>  | <p><b>A1</b></p> | <p>(11) International Publication Number: <b>WO 96/25015</b><br/>(43) International Publication Date: 15 August 1996 (15.08.96)</p>   |
| <p>(21) International Application Number: PCT/SE96/00099<br/>(22) International Filing Date: 30 January 1996 (30.01.96)<br/>(30) Priority Data:<br/>9500408-1 6 February 1995 (06.02.95) SE<br/>(71) Applicant (for all designated States except US): TELIA AB [SE/SE]; S-123 86 Farsta (SE).<br/>(72) Inventors; and<br/>(75) Inventors/Applicants (for US only): HJERN, Magnus [SE/SE]; Solstigen 6, S-230 33 Smygehamn (SE). OLANDERS, Peter [SE/SE]; Sjögräsgatan 12, S-234 33 Lomma (SE).<br/>(74) Agent: KARLSSON, Berne; Telia Research AB, Rudsjöterrassen 2, S-136 80 Haninge (SE).</p> |                  | <p>(81) Designated States: US, European patent (AT, BE, CH, DE, DK, ES, FR, GB, GR, IE, IT, LU, MC, NL, PT, SE).<br/><b>Published</b><br/><i>With international search report.<br/>Before the expiration of the time limit for amending the claims and to be republished in the event of the receipt of amendments.</i></p> |

(54) Title: ARRANGEMENT FOR HANDOVER IN A MOBILE TELECOMMUNICATIONS NETWORK

(57) Abstract

The present invention relates to a system comprising first and second mobile telecommunications systems, for example DECT and GSM. The first mobile telecommunications system is arranged to serve a geographically limited area, while the second mobile telecommunications system serves larger geographical areas, for example a country, countries, etc. Mobile units are arranged for communication with the respective system. A transition zone is identified at the outer edge of the coverage area for the first mobile telecommunications network. When the mobile unit enters this area, the said unit detects the quality of the connection and initiates a transition to the second telecommunications network if the quality of the connection is below a predetermined value or if the quality of the connection comes near to this value. The transition between the different systems is thus initiated by the mobile.

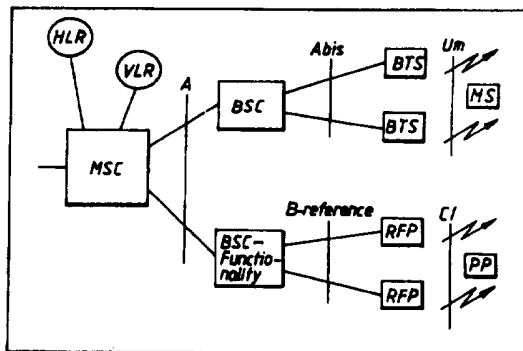

**FOR THE PURPOSES OF INFORMATION ONLY**

Codes used to identify States party to the PCT on the front pages of pamphlets publishing international applications under the PCT.

|    |                          |    |  |    |                          |
|----|--------------------------|----|--|----|--------------------------|
| AM | Armenia                  | GB | United Kingdom                           | MW | Malawi                   |
| AT | Austria                  | GE | Georgia                                  | MX | Mexico                   |
| AU | Australia                | GN | Guinea                                   | NE | Niger                    |
| BB | Barbados                 | GR | Greece                                   | NL | Netherlands              |
| BE | Belgium                  | HU | Hungary                                  | NO | Norway                   |
| BF | Burkina Faso             | IE | Ireland                                  | NZ | New Zealand              |
| BG | Bulgaria                 | IT | Italy                                    | PL | Poland                   |
| BJ | Benin                    | JP | Japan                                    | PT | Portugal                 |
| BR | Brazil                   | KE | Kenya                                    | RO | Romania                  |
| BY | Belarus                  | KG | Kyrgyzstan                               | RU | Russian Federation       |
| CA | Canada                   | KP | Democratic People's Republic<br>of Korea | SD | Sudan                    |
| CF | Central African Republic | KR | Republic of Korea                        | SE | Sweden                   |
| CG | Congo                    | KZ | Kazakhstan                               | SG | Singapore                |
| CH | Switzerland              | LI | Liechtenstein                            | SI | Slovenia                 |
| CI | Côte d'Ivoire            | LK | Sri Lanka                                | SK | Slovakia                 |
| CM | Cameroon                 | LR | Liberia                                  | SN | Senegal                  |
| CN | China                    | LT | Lithuania                                | SZ | Swaziland                |
| CS | Czechoslovakia           | LU | Luxembourg                               | TD | Chad                     |
| CZ | Czech Republic           | LV | Latvia                                   | TG | Togo                     |
| DE | Germany                  | MC | Monaco                                   | TJ | Tajikistan               |
| DK | Denmark                  | MD | Republic of Moldova                      | TT | Trinidad and Tobago      |
| EE | Estonia                  | MG | Madagascar                               | UA | Ukraine                  |
| ES | Spain                    | ML | Mali                                     | UG | Uganda                   |
| FI | Finland                  | MN | Mongolia                                 | US | United States of America |
| FR | France                   | MR | Mauritania                               | UZ | Uzbekistan               |
| GA | Gabon                    |    |  | VN | Viet Nam                 |

APPLICANT: TELIA AB

TITLE OF THE INVENTION: ARRANGEMENT FOR HANDOVER IN A  
MOBILE TELECOMMUNICATIONS NETWORK

TECHNICAL FIELD

5           The present invention relates to an arrangement  
for a telecommunications system which permits automatic  
handover function between a cordless or cellular radio  
communications system during an ongoing call.

PRIOR ART

10           It is already known, from patent specifications  
WO 93/16549, US 5 260 988, US 5 127 042 and US 4 989 230,  
to arrange communications systems which consist of both  
cordless telephony and cellular mobile telephone systems.  
The specifications describe systems comprising portable  
15 cordless units which can initiate and receive calls in  
the cordless or the cellular system. The documents  
describe how calls are connected automatically to the  
system in which the subscriber is located. The documents  
thus describe how a user is joined to one or other of the  
20 systems. The user moreover has the possibility of  
selecting one of the systems manually by means of press  
button procedure.

          US patent specification 5 235 632 describes a  
mobile telephone system which consists of an outdoor  
25 system, consisting of base stations with high transmitter  
power which are divided into cells and are connected to  
a mobile telephone exchange, and of an indoor system,  
consisting of base stations with low transmitter power  
which are connected to a mobile telephone exchange.  
30 According to the document, there is a possibility of  
connecting a call between the inside system and outside  
system, for example by measuring the signal strength from  
the respective system.

          In addition, the document US 5 309 502 describes  
35 a radio telephone which combines the functions of a

- 2 -

cordless telephone and a cellular mobile telephone. It is possible, when connecting calls, to select automatically the system via which the communication will take place.

5 US patent specification 5 210 785 describes a cordless communications system and a terminal which combines two different systems such as cordless telephony and cellular mobile telephony. The choice of the method of communication is made automatically.

10 US patent specification 5 329 574 describes a method for maintaining continuous telephone communication when a radio communications unit moves between two different communications systems. When the unit discovers that the quality of communication is deteriorating in a first system, a connection packet is sent to a central  
15 control unit of a second system. The communication in the first system is maintained until the second system acknowledges acceptance of the communication.

20 US patent specification 5 212 684 relates to a communications system which uses hand-held radio telephones. The system consists of base stations and portable telephone units in accordance with the GSM standard. The portable telephone stations can also operate in accordance with the DECT standard. The system performs both internal and external handover. Handover  
25 between DECT and GSM is not described, however.

Digital European Cordless Telecommunications, DECT, is a system which has been specified within the ETSI for cordless communication in a number of application areas, for public applications, for private  
30 use within, for example, business systems, or for domestic use, and for radio access in the local network. Although DECT has great similarities to the traditional mobile telephone systems, the basic standard does not have descriptions for the functionality of the network.  
35 For this purpose, special access profiles are specified instead, which access profiles describe the connection to, and the interaction with, the background network elements.

Work is in progress on a profile of this kind for

**SUBSTITUTE SHEET**

cooperation with GSM, the DECT/GSM Interworking Profile. The standards in this profile describe how functions and messages in GSM will be able to be transmitted via a DECT radio system, together with requests for services, how  
5 the functional connection to the GSM exchange, the MSC, will take place, and how type-testing of equipment will be carried out. First, it will be possible for voice services to be offered by means of direct connection to the GSM network, but in the standard there is also  
10 provision for being able to use DECT for other purposes, for example message services, additional services and data transmission. The invention which is described in this application may come to be included in some of these standards.

15 DECT is an extremely flexible standard which combines high system capacity, within traffic-intensive areas, and good quality in terms of both voice services and data services. The limited radio coverage of the system means, however, that DECT systems are very local,  
20 and DECT can scarcely be extended to cover such large areas as are covered by a mobile telephone network. A combined system, in which DECT utilizes the mobility functions and very extensive radio coverage of GSM, may in this way come to represent a both powerful and  
25 flexible access solution in a number of application areas. At the same time as users gain access to the services and functions of the GSM network, the infrastructure of the network can be utilized more efficiently, and operators have access to new markets.

30 The fixed side of DECT can be divided into Radio Fixed Parts, RFPs, and a central unit, Central Fixed Part, CFP. Together they form a Fixed Part, FP. RFPs connected to a common central unit constitute a so-called cluster and serve all portables, PP, within a coverage  
35 area. The CFP can, for example, be an integrated part in a PABX, or can constitute part of the local exchange, LX. This DECT system is owned or administered either by a public telephone operator or by a private operator.

In more advanced application areas, the CFP of

- 4 -

the system can also include local data bases, the Home Data Base, HDB, and the Visitors Data Base, VDB, but their intelligence can also be implemented directly in the CFP or, as in the case of GSM, can be supported by  
5 functions in the background network.

A DECT system connected to the GSM network replaces, in this architecture, the base station and radio systems in GSM. The special InterWorking Unit, IWU, can consist of a distinct unit or can be a part of the  
10 DECT FP. This emulates the functionality of the GSM BSC and is thus responsible for ensuring that the functionality and the messages specified via GSM's A interface (Figure 1) are transmitted to the terminal.

A DECT terminal, or portable, needs to be able to  
15 handle GSM's identity structure in order to be connected-in to the combined DECT/GSM environment. There are also requirements as regards security routines, for example authentication and encryption of user data.

There is reason to suppose that the user, as long  
20 as it is a matter of the same type of communication, will see considerable value in having to use only one terminal for this communication. Combined handsets for DECT and GSM, so-called dual mode terminals (Figure 2), are therefore an important component in the integration of  
25 the systems. In the present climate it is considered very probable that combined sets for DECT/GSM will be on the market within a period of 3 years.

With a combined DECT/GSM terminal, there will of course also be a requirement for it to be possible to  
30 maintain the communication at a change-over between the different access systems. However, transferring an ongoing call from DECT to GSM, i.e. handover, is not as yet described in any of the standards relating to interaction between the systems.

## 35 DESCRIPTION OF THE INVENTION

### Technical problem

In mobile telecommunications, the mobile is linked to a specific system, for example GSM, DECT, etc.

**SUBSTITUTE SHEET**

- 5 -

The GSM system is used for communication over large geographical areas, for example a country, countries, or other large geographical divisions. In addition, radio systems of the DECT type exist which are intended to be used within limited areas. The latter systems are as a rule covered by the more overlapping systems of the GSM type. Users employing the DECT systems wanted to employ the GSM system in some situations. For this purpose, mobiles have been developed which have the possibility of being connected to both the GSM and DECT systems. The said mobiles in this case contain the necessary technology for communication via the respective system. A mobile which is on the move and is being conveyed out from the DECT system comes gradually to lose contact with the said system, in which case there is a requirement for the call to be transferred to the GSM system. In the systems which have been known hitherto, this transfer, or handover, has been effected by manual control from the mobile. In order to achieve a continuous communication, there is therefore a requirement that the transfer, or handover, from the DECT system to the GSM system will take place automatically. The necessary connections will be established for this, and the link-up takes place without the user having to take any special measures.

Automatic switch-over of calls, or handover, is a very important function in order to be able to offer users complete mobility over several application areas, irrespective of whether DECT or GSM access is used for the GSM service. Its use is particularly important given the new operator structures which will inevitably be developed with DECT technology, since this permits a transfer between private and public networks, a functionality which is at present lacking in GSM.

The handover functionality between the DECT and GSM systems therefore represents, for the operator, a significant competitive advantage over other players on the market. It is therefore of immediate interest to find a solution for handover from DECT to GSM in which both systems are operated by the same operator, a function for

**SUBSTITUTE SHEET**

- 6 -

DECT-GSM intra-operator handover. The fact that this type of handover (DECT → GSM) is the one which should be dealt with first is based on the fact that the coverage of the GSM system is general (covers large areas). This means  
5 that it will be possible to effect a handover from a DECT system to a GSM system under most circumstances.

Technical problems in the present application are:

- 10 • A DECT radio system, connected to the background GSM network, can utilize the mobility functionality of the network to make switch-over between the systems possible. However, it is necessary that information can be transferred between the terminal and the network, that is between the DECT FP and the GSM MSC, in accordance with  
15 the requirements which are defined in DECT/GSM IWP.
- Since the communication with the different radio systems in DECT and GSM takes place independently, an automatic switch-over presupposes that a DECT/GSM dual-mode terminal is being utilized by the user.
- 20 • A GSM handover presupposes that the mobile station is assisting the network with measurement data concerning the radio environment. The radio parts (OSI layers 1 - 2) in a dual-mode terminal are not, however, assumed to be active at the same time in the terminal for the DECT and  
25 GSM systems. Handover in DECT has a completely different functionality from that in GSM. The traditional handover methods which exist in DECT or GSM cannot therefore be used without modification for a switch-over between the systems.
- 30 • Handover should not be a slow procedure. From DECT to GSM, it may be acceptable for the handover to be perceptible, but the time requirements are still high. The radio conditions in the microcell or picocell environment mean that the switch-over has to be prepared  
35 for in advance in the fixed system parts.
- For reasons of time, necessary signalling should be kept to a minimum.
- In order to maintain a high quality of connection, unnecessary handover must be avoided, i.e. switch-over to

**SUBSTITUTE SHEET**

- 7 -

a GSM cell takes place only when DECT coverage is lacking.

• It should be possible for the switch-over to take place fully automatically, without the user having to take any measures, or by a new call connection (three-way call) being established.

• Additional requirements are that it should be possible to implement the solution for handover at reasonably low costs, and without the need for extensive modifications to software in already existing terminals.

The object of the present invention is to solve the problems mentioned.

#### SOLUTION

The present invention relates to an arrangement for handover in a mobile telecommunications network. A mobile unit is arranged to communicate via a first and/or second mobile telecommunications network. The first mobile telecommunications network is arranged to serve a geographically limited area, and the second mobile telecommunications network is arranged to serve a larger geographical area, which geographical area can be a country, countries, etc. The larger geographical area at least partially covers the smaller geographical area. The mobile unit is arranged with functionalities for the respective mobile telecommunications network. This means that the mobile unit can be used in both the first and the second telecommunications network. During the call, the mobile unit detects the quality of the communication upon communication via the first mobile telecommunications network. The quality of the communication is determined by the mobile unit which decides when the quality falls below or comes near to a minimum acceptable level. When the quality of the communication falls below or comes near to the minimum acceptable level, the mobile unit transfers the communication to the second mobile telecommunications network. The transition, or handover, from the first telecommunications network to the second telecommunications network is arranged to take place

**SUBSTITUTE SHEET**

automatically.

In a further development of the invention, the first and second telecommunications networks are arranged to communicate with each other. The first and second  
5 communications networks are arranged to communicate with each other via a cordless telephone network. The first mobile telecommunications network moreover consists of a cordless telecommunications network and is arranged to serve a number of first base stations within the  
10 geographical area. The second mobile telecommunications network is arranged to be served by a number of second base stations within the larger geographical area. The first telecommunications network is preferably a DECT system and the second mobile telecommunications network  
15 is preferably a GSM system. A handover zone is moreover arranged at the outer edge of the first mobile telecommunications network.

#### DESCRIPTION OF THE FIGURES

Figure 1 shows the system architecture for a  
20 system according to the invention.

Figure 2 shows an example where GSM and DECT communication is taking place, and the actual coverage area.

Figure 3 shows a GSM cell, and a DECT cluster in  
25 which the handover zone is marked.

Figure 4 shows the DECT to GSM handover situation.

#### DETAILED EMBODIMENT

The solution builds on the following basic  
30 particulars:

1) DECT RFPs which cover the edge of the system belong to the zone of handover to GSM and can be identified in particular by the CTP/IWU (Figure 3). This edge area is also covered by traditional GSM radio access  
35 via one or more BTS, and it is this factor which makes a switch-over between the systems possible.

2) When the terminal is located in the handover

- 9 -

zone during an ongoing call, an external handover to GSM can be initiated as follows:

2.1) The terminal activates handover when the field strength on the DECT connection has become so low that a call can no longer be maintained with sufficient quality. The possibility also exists of initiating handover, from the operator, for other reasons, for example type of subscription, geographical position, etc.

2.2) The CFP/IWU utilizes its BSC functionality and requests of the GSM MSC that a handover between two base station systems be effected.

3) Following acknowledgement from the network and a handover command, the contact of the terminal with the DECT system is broken, and the terminal changes instead to GSM mode. Contact is established with the "new" base station, BTS, and the handover is completed to GSM MSC.

4) Handover can be broken off if, for example, the terminal leaves the particular handover zone.

The present application is based on novel and unique combinations of known techniques being combined with novel elements. Some of the most important particulars of the invention are summarized below. See also the notes in Figure 5.

a) In contrast to GSM, it is the terminal itself which initiates handover from the viewpoint of the DECT system. It is therefore this terminal which starts the whole switch-over procedure. For the dual mode terminal to be able to carry out handover, it is necessary for common DECT/GSM functions to be built into the terminal. This can be, for example, subscriber information, functions for registering in different systems and networks, and rerouting of conventional functions upon handover between the systems. A specific requirement of the dual mode terminal is that it will be able to request information for handover to GSM when the DECT coverage is inadequate.

b) The CFP/IWU is the unit which, from the viewpoint of the GSM network, is responsible for initiating handover. The CFP/IWU will be able to

**SUBSTITUTE SHEET**

- 10 -

interpret a request for handover from the terminal and translate it to a GSM-specific message, which is transmitted to the GSM MSC.

5 c) In the invention, the IWU is pre-programmed with the necessary data for the GSM cell in which the local DECT system is located. It will be possible for this data to be used in the request for handover to the MSC for the BTS/BSC combination in question and thereby designate the relevant GSM cell of the DECT system.

10 d) The CFP/IWU will be able to receive the switch-over order in the network and transmit this to the terminal. The information concerning the frequency and identity of the new GSM cell is given to the terminal in the message of acknowledgement to its original handover request.

15 One of the most outstanding features of DECT is the possibility of using several different identities simultaneously in one and the same terminal, and of indicating, from the FP, which type of access rights goes with these identities. For a DECT user directly coupled to an background GSM network, a combination of PARK and IPUI is defined which makes the DECT subscription valid in GSM too.  $IPUI_R$  is identical to the identity IMSI defined in GSM, while  $PARK_{\{D\}}$  points to GSM access rights.

20 For reasons of radio efficiency, there is a shortened identity which is valid only within the search area, or location area, in which the terminal is located. This Temporary Portable User Identity, TPUI, is used for calls or paging to a specific terminal and is directly equivalent to the GSM TMSI.

25 A DECT/GSM dual-mode terminal has the possibility of storing several sets of identities and system parameters independently of each other. This means that the terminal can use simultaneous subscriptions in, for example, a private company network and in relation to an background GSM network. Handover in DECT is normally initiated by the terminal, so-called mobile originated handover, either because the radio channel is subject to interference or for reasons of coverage. Such internal

30

35

**SUBSTITUTE SHEET**

- 11 -

handover within a DECT FP is managed fully within the framework of the local DECT system and requires no interaction with background network elements. Switch-over to another CFP or to GSM is called external handover and can be decided either by the terminal or the CFP/IWU. In this invention, we start from the premise that it is the terminal which, in DECT mode, has the best knowledge of the radio-related conditions and therefore initiates the switch-over, which is also the most common and the intended form in DECT.

A terminal which, during an ongoing call, communicates via  $RFP_n$ - $RFP_{n+3}$  (Figure 3) is located within the particular area which is identified as the handover zone (marked by [lacuna] in the figure). When the field strength from the RFP has dropped so low that the call quality may be affected, the terminal proposes that an external handover should be carried out (Figure 5). The terminal here uses its GSM subscription, which includes necessary identity, encryption key and authentication key.

A handover in GSM is decided by the control function of the base station system, BSC, on the basis of, among other things, measurement data from the mobile concerning the signal levels of the surrounding base stations, BTS. In the local DECT system, the CFP/IWU is therefore the unit which, from the viewpoint of the GSM network, is responsible for initiating the switch-over and emulates so-called mobile assisted handover. A switch-over to GSM further involves the connection being taken over by another base station system. This inter-BSC - intra-MSC handover requires that the GSM MSC participates in the switch-over.

Since the terminal in DECT usually initiates handover itself, the CFP/IWU needs to be able to interpret such a request and convey it onwards to the MSC. The terminal requests of the CFP that a handover to GSM be carried out, {MM-INFO-REQUEST}, and asks for the necessary parameters from the network. In the invention the IWU is pre-programmed with the necessary data for the

**SUBSTITUTE SHEET**

- 12 -

cell in which the local DECT system is located. In the request for handover, HANDOVER-REQUIRED, this data is included as part of the information which is transmitted to the MSC.

5           The MSC conveys the handover procedure onwards to the designated base station system in GSM, HANDOVER-REQUEST, and can, upon a successful acknowledgement from the said system, HANDOVER-REQUEST-ACK, give the terminal a command that switch-over be carried out, HANDOVER-  
10   COMMAND.

          The CFP/IWU transmits this command to the terminal in the message of acknowledgement to its original request for handover, {MM-INFO-ACCEPT}. In this message the terminal obtains information indicating to  
15   which base station, and at which frequency, it is to establish contact via GSM radio access.

          A rejected attempt at switch-over is acknowledged with {MM-INFO-REJECT}, see hereinbelow.

          In the case of a successful switch-over attempt,  
20   the CFP now terminates the DECT connection with the terminal, {CC-RELEASE}, {CC-RELEASE-COM}, in order that the two parties will be able to effect a switch-over to the new GSM link. Until this link has been established, there is a temporary interruption in the ongoing call.

25           Handover can take place synchronously or asynchronously in GSM. Synchronous handover reduces the interruption time (from about 200 msec to about 100 msec), but it requires that mobile stations have the possibility, in conjunction with the transmission of  
30   measurement data, of providing the network with synchronization information on the base stations involved (pseudo timing advance). In the technical solution, use is made of asynchronous handover in which the terminal synchronizes itself with respect to the new base station  
35   in conjunction with the connection of the new GSM link. It is possible for synchronous handover also to be used within the scope of the invention, which would make it possible to reduce the interruption time. However, this probably imposes greater technical demands on the

**SUBSTITUTE SHEET**

equipment, with modifications to the fixed system units in DECT.

Immediately after disconnection of the DECT link, the GSM part in the terminal is activated, and the communication with GSM is established. This is achieved by means of the terminal sending the message HANDOVER-ACCESS, at the designated carrier frequency, until the base station responds with PHYSICAL-INFORMATION in order to give the terminal the necessary information concerning the new link. After a synchronised, clear and encrypted connection has once again been established between the two parties, the terminal finishes the switch-over by sending HANDOVER-COMplete, which is conveyed onwards via the base station system to the MSC. The call is connected through, and the conversation can continue. The MSC is also responsible for terminating the former connect path through, and the conversation can continue. The MSC is also responsible for terminating the former connect path through the DECT system.

A prepared handover can be interrupted for a number of reasons. For example, the terminal may, via internal handover, have changed base station within the DECT system to an RFP lying "deeper" in the DECT cluster than the defined handover zone. The call continue to be served with DECT access, without further measures needing to be taken.

Handover can also be interrupted for operator reasons, because the terminal is not provided with the necessary GSM parameters, or because a negative acknowledgement is obtained from the GSM MSC (see Figure 5). In this case, the terminal should not interrupt the ongoing call, but should instead maintain the connection via DECT for as long as this is possible.

The present invention is not limited to what has been shown above by way of example, but can instead be modified in respect of the inventive concept and the attached patent claims.

In fig 1:

HLR = Home Location Register  
VLR = Visitors Location Register  
MSC = Mobile Switching Centre  
BSC = Base Station Controller  
5 BTS = Base Transceiver Station  
Um =GSM Radio Interface  
MS = Mobile Station  
IWU = Internetworking Unit  
CFP = Central Fixed Part  
10 RFP = Radio Fixed Part  
CI = DECT Common (Air)Interface  
PP = Portable Part

15 Fig 2 is describing a DECT/GSM dual-mode terminal.

Fig 3 is describing a DECT to GSM zone.

Fig 4 is describing a DECT to GSM handover situation.

20 Fig 5 is describing messages on automatic handover form DECT to GSM. In fig 5:

25 10 = Info type = external handover parameters,  
Network-Parameter = GSM handover reference requested.

11 = Info type = external handover parameters,  
Network-Parameter = GSM handover reference.

30 12 = Reject reason.

13 = Release reason = External handover release,  
Network-Parameter = GSM handover reference.

35 14 = Release reason = external handover release,  
Network-Parameter = GSM handover reference.

## PATENT CLAIMS

1. Arrangement for handover in a mobile tele-  
communications network, in which a mobile unit is  
arranged to communicate via a first and/or second mobile  
5 telecommunications network, the first mobile tele-  
communications network being arranged to serve a  
geographically limited area, and the second mobile  
telecommunications network being arranged to serve a  
larger geographical area, with the larger geographical  
10 area at least partially covering the smaller geographical  
area, and the mobile unit being arranged with  
functionalities for the respective mobile tele-  
communications network, characterized in that the mobile  
unit is arranged to detect the quality of an ongoing  
15 communication upon communication via the first mobile  
telecommunications network, in that the mobile unit is  
arranged to determine when the quality of the  
communication falls below or comes near to a minimum  
acceptable level, in that the mobile unit is arranged to  
20 transfer the communication to the second mobile tele-  
communications network when the quality of the  
communication falls below or comes near to the minimum  
acceptable level, and in that the transition, or  
handover, from the first mobile telecommunications  
25 network to the second telecommunications network can be  
carried out.

2. Arrangement according to Patent Claim 1,  
characterized in that the transition from the first  
mobile telecommunications network to the second mobile  
30 telecommunications network takes place automatically.

3. Arrangement according to either of the preceding  
patent claims, characterized in that the first and second  
telecommunications networks are arranged to communicate  
with each other.

35 4. Arrangement according to Patent Claim 3,  
characterized in that the first and second communications  
networks are arranged to communicate directly with each  
other and/or via a cordless telephone network.

5. Arrangement according to any one of the preceding patent claims, characterized in that the first mobile telecommunications network consists of a cordless telecommunications network.

5 6. Arrangement according to Patent Claim 5, characterized in that the first mobile telecommunications network is arranged to be served by a number of first base stations within the geographically limited area.

10 7. Arrangement according to Patent Claims 1 to 3, characterized in that the second mobile telecommunications network is arranged to be served by a number of second base stations within the larger geographical area.

15 8. Arrangement according to any one of the preceding patent claims, characterized in that the first telecommunications network is preferably a DECT system and the second mobile telecommunications network is preferably a GSM system.

20 9. Arrangement according to any one of the preceding patent claims, characterized in that a handover zone is arranged at the outer edge of the first mobile telecommunications network.

25 10. Arrangement according to any one of the preceding patent claims, characterized in that the first and the second mobile telecommunications networks, respectively, are arranged to be operated by a common operator.

30 11. Method for handover in a mobile telecommunications network, in which a mobile unit communicates with a first and/or second mobile telecommunications network, and the first mobile telecommunications network serves a geographically limited area, and the second mobile telecommunications network serves a larger geographical area, which completely or partially covers the geographically limited area, and the mobile unit is given functions for communication with the  
35 first or second mobile telecommunications network, respectively, characterized in that the mobile unit detects the quality of an ongoing communication via the first mobile telecommunications network, in that the

mobile unit determines when the quality falls below/ comes near to a minimum acceptable level, when the communication is transferred from the first to the second mobile telecommunications network.

5 12. Method according to Patent Claim 11, characterized in that the mobile unit initiates connection to the second mobile telecommunications network, and disconnection of the first mobile telecommunications network.

10 13. Method according to Patent Claim 12, characterized in that the disconnection with respect to the first telecommunications network is effected when the connection to the second mobile telecommunications network has been effected.

1 / 3

Fig. 1

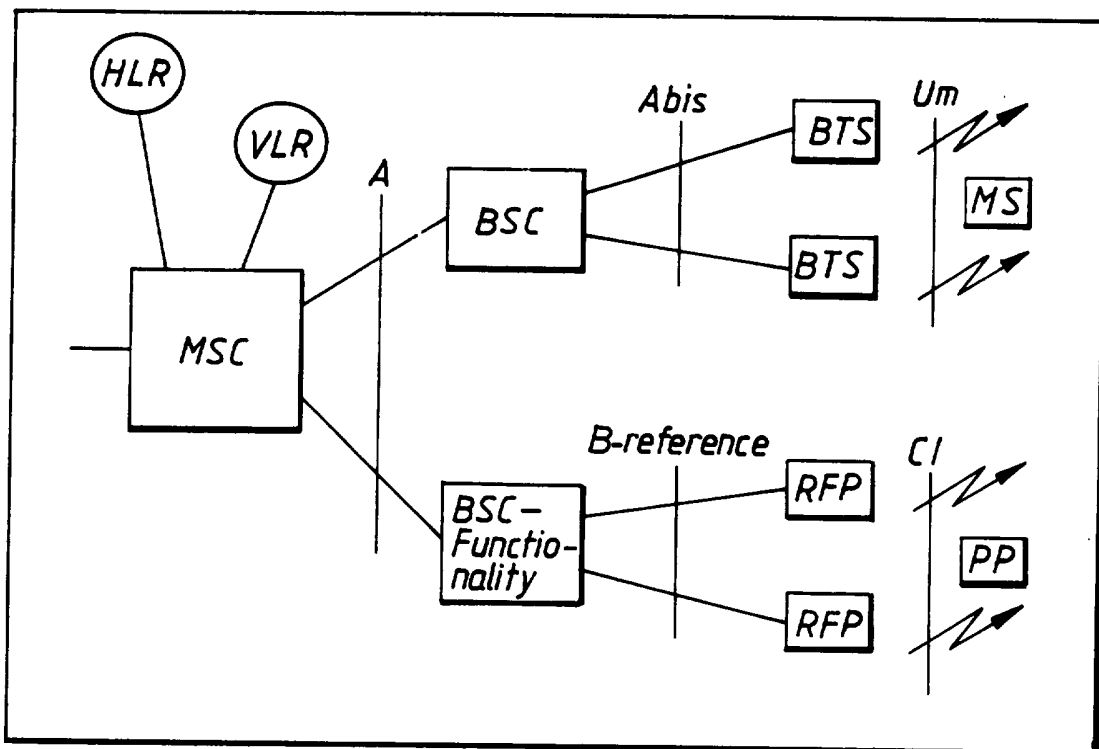

Fig. 2

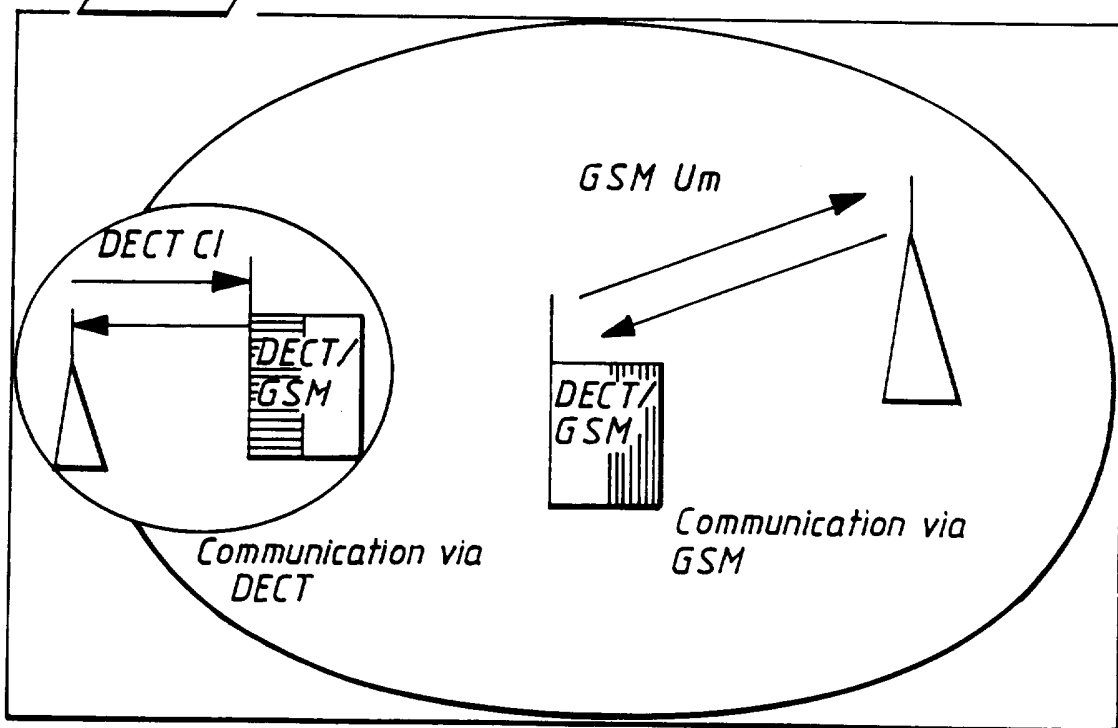

Fig. 3

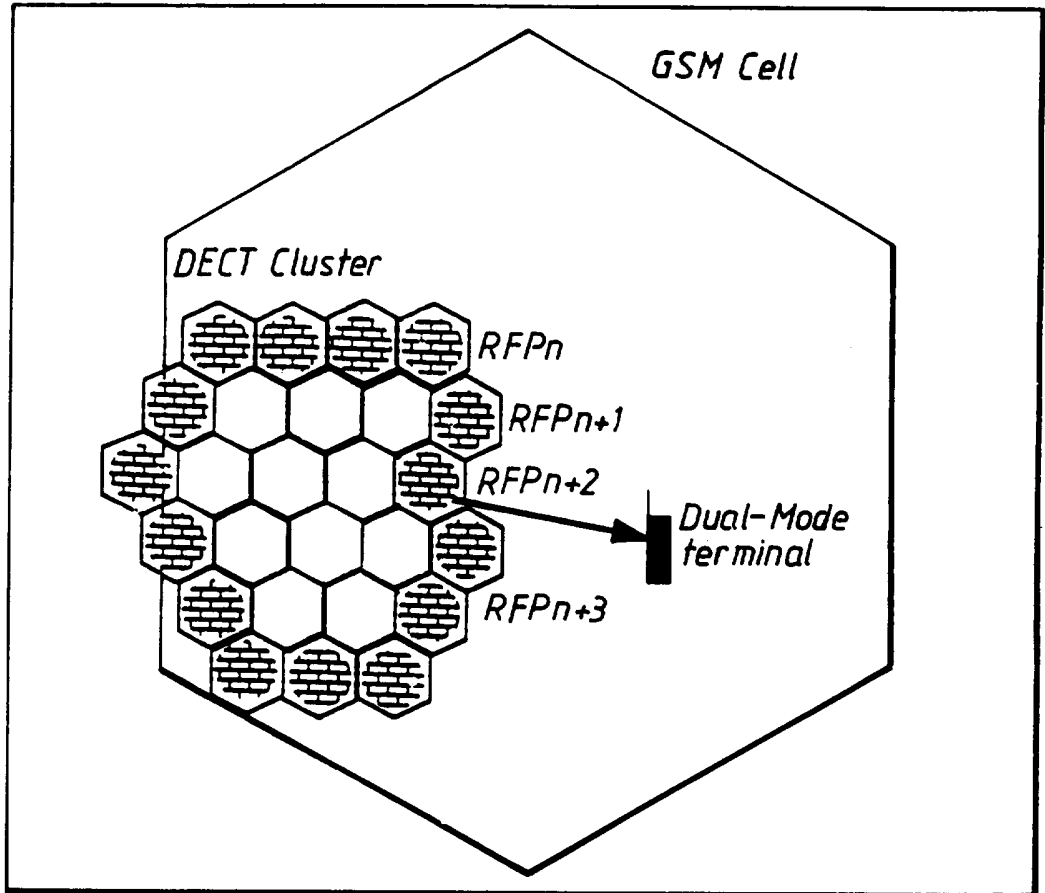

Fig. 4

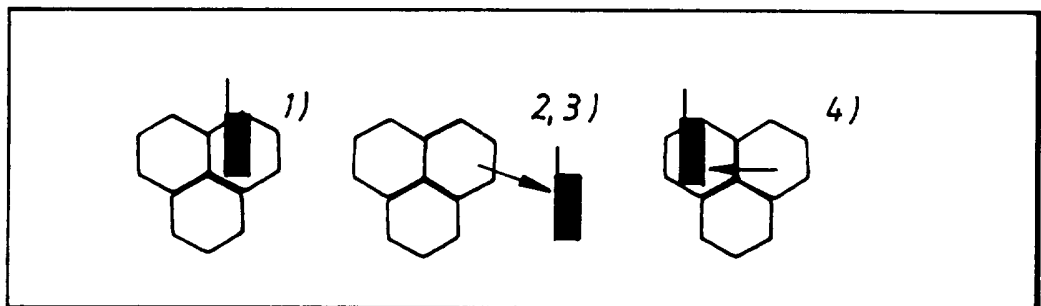
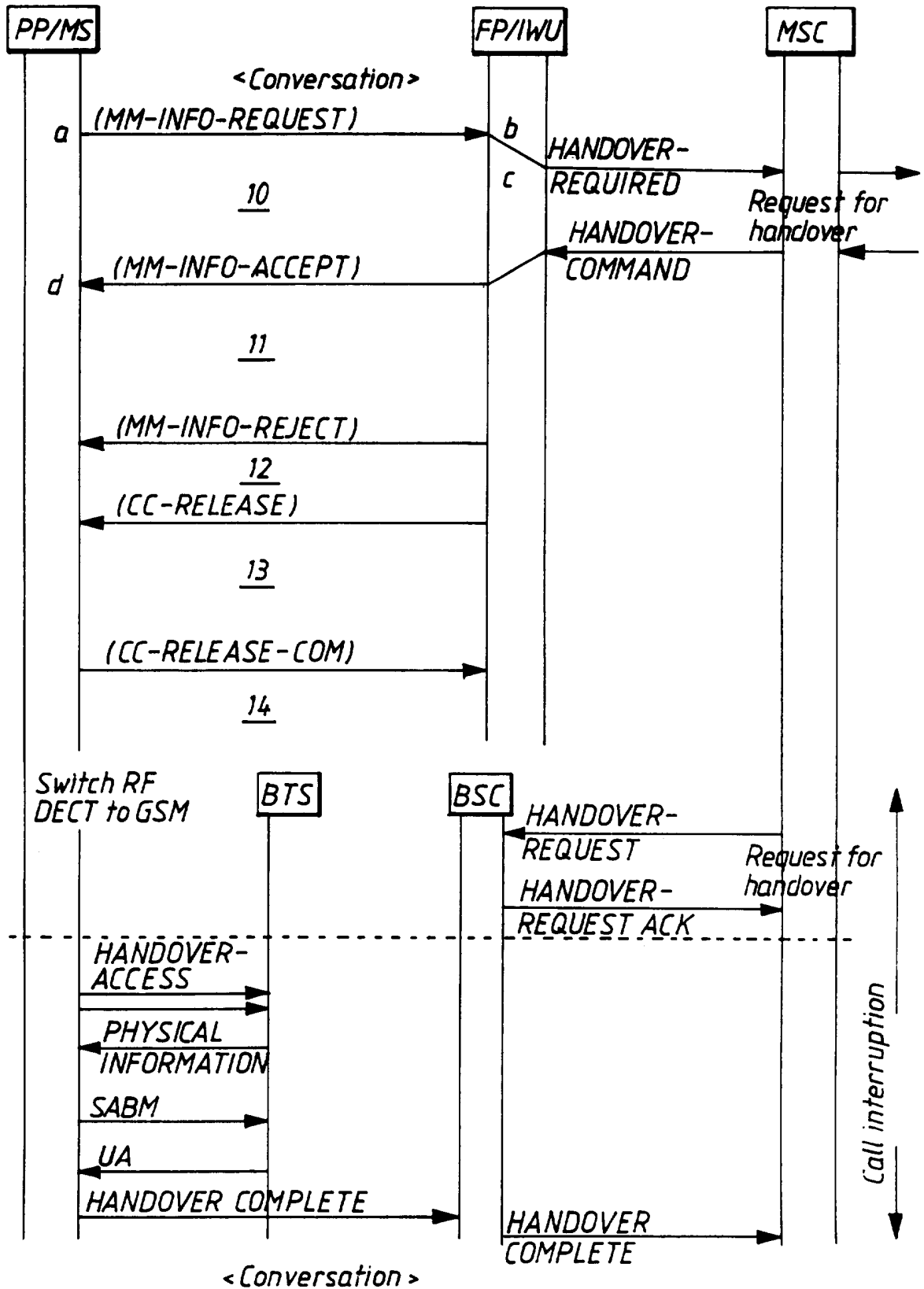

Fig. 5



## INTERNATIONAL SEARCH REPORT

International application No.

PCT/SE 96/00099

| <b>A. CLASSIFICATION OF SUBJECT MATTER</b>   |  |   |
|--|--|---|
| IPC6: H04Q 7/38<br>According to International Patent Classification (IPC) or to both national classification and IPC   |  |   |
| <b>B. FIELDS SEARCHED</b>  |  |   |
| Minimum documentation searched (classification system followed by classification symbols)  |  |   |
| IPC6: H04Q   |  |   |
| Documentation searched other than minimum documentation to the extent that such documents are included in the fields searched  |  |   |
| SE,DK,FI,NO classes as above   |  |   |
| Electronic data base consulted during the international search (name of data base and, where practicable, search terms used)   |  |   |
| <b>C. DOCUMENTS CONSIDERED TO BE RELEVANT</b>  |  |   |
| Category*  | Citation of document, with indication, where appropriate, of the relevant passages   | Relevant to claim No.   |
| X  | WO 9316549 A1 (MOTOROLA, INC.), 19 August 1993<br>(19.08.93), page 2, line 32 - page 3, line 3;<br>page 4, line 11 - line 13; page 6,<br>line 4 - line 21, page 9, line 30 - page 10, line<br>10; page 13, line 1 - line 11; page 14, line 33 -<br>page 15, line 26; page 16, line 15 - line 23<br><br>--<br>----- | 1-13  |
| <input type="checkbox"/> Further documents are listed in the continuation of Box C. <input checked="" type="checkbox"/> See patent family annex.   |  |   |
| <p>* Special categories of cited documents:</p> <p>"A" document defining the general state of the art which is not considered to be of particular relevance</p> <p>"E" earlier document but published on or after the international filing date</p> <p>"L" document which may throw doubts on priority claim(s) or which is cited to establish the publication date of another citation or other special reason (as specified)</p> <p>"O" document referring to an oral disclosure, use, exhibition or other means</p> <p>"P" document published prior to the international filing date but later than the priority date claimed</p> <p>"T" later document published after the international filing date or priority date and not in conflict with the application but cited to understand the principle or theory underlying the invention</p> <p>"X" document of particular relevance: the claimed invention cannot be considered novel or cannot be considered to involve an inventive step when the document is taken alone</p> <p>"Y" document of particular relevance: the claimed invention cannot be considered to involve an inventive step when the document is combined with one or more other such documents, such combination being obvious to a person skilled in the art</p> <p>"&amp;" document member of the same patent family</p> |  |   |
| Date of the actual completion of the international search  |  | Date of mailing of the international search report                      |
| 11 June 1996   |  | 12 -06- 1996  |
| Name and mailing address of the ISA/<br>Swedish Patent Office<br>Box 5055, S-102 42 STOCKHOLM<br>Facsimile No. +46 8 666 02 86   |  | Authorized officer<br><br>Peter Hedman<br>Telephone No. +46 8 782 25 00 |

**INTERNATIONAL SEARCH REPORT**  
Information on patent family members

01/04/96

International application No.  
PCT/SE 96/00099

| Patent document cited in search report | Publication date | Patent family member(s) | Publication date |
|--|------------------|-------------------------|------------------|
| WO-A1- 9316549                         | 19/08/93         | BR-A- 9304158           | 02/08/94         |
|  |                  | CA-A- 2105966           | 07/08/93         |
|  |                  | CN-A- 1076817           | 29/09/93         |
|  |                  | CN-A- 1109253           | 27/09/95         |
|  |                  | CZ-A- 9302091           | 19/10/94         |
|  |                  | FR-A- 2687875           | 27/08/93         |
|  |                  | GB-A,B- 2271040         | 30/03/94         |
|  |                  | IT-D- RM930066          | 00/00/00         |
|  |                  | JP-T- 6507059           | 04/08/94         |

---