



US00D768313S

(12) **United States Design Patent**  
**Kagawa**

(10) **Patent No.:** **US D768,313 S**

(45) **Date of Patent:** **\*\* Oct. 4, 2016**

(54) **AUTOCLAVE**

(71) Applicant: **Takeshi Kagawa**, Kanuma (JP)

(72) Inventor: **Takeshi Kagawa**, Kanuma (JP)

(73) Assignee: **Nakanishi Inc.**, Kanuma-shi (JP)

(\*\*) Term: **14 Years**

(21) Appl. No.: **29/519,241**

(22) Filed: **Mar. 3, 2015**

(51) **LOC (10) Cl.** ..... **24-01**

(52) **U.S. Cl.**  
USPC ..... **D24/217**

(58) **Field of Classification Search**  
USPC ..... D24/216, 217, 218, 227-232; D32/1,  
D32/25

CPC ..... A61L 2/26; A61L 24/17; A61L 2/18;  
A61L 2/025; A61L 2202/122; A61L 2202/10;  
A61L 2202/11; A61L 2202/14; A61L  
2202/23; A61L 2202/24; A61L 2202/182  
See application file for complete search history.

(56) **References Cited**

**U.S. PATENT DOCUMENTS**

D404,827 S \* 1/1999 Thoburn ..... D24/217  
6,797,233 B1 \* 9/2004 De Heus ..... A61L 2/07  
422/113

D546,473 S \* 7/2007 Xu ..... D24/217  
D551,773 S \* 9/2007 Sheldon ..... D24/217  
D632,800 S \* 2/2011 Nanni ..... D24/217  
D688,839 S \* 8/2013 Helm ..... D32/1  
2014/0017118 A1 \* 1/2014 Stoddard ..... A61L 2/28  
422/1

\* cited by examiner

*Primary Examiner* — Anhdao Doan

(74) *Attorney, Agent, or Firm* — Jason D. Voight

(57) **CLAIM**

The ornamental design for an autoclave, as shown and described.

**DESCRIPTION**

FIG. 1 is a front view of an autoclave;  
FIG. 2 is a rear view thereof;  
FIG. 3 is a top view thereof;  
FIG. 4 is a bottom view thereof;  
FIG. 5 is a left side view thereof;  
FIG. 6 is a right side view thereof; and,  
FIG. 7 is a perspective view from upper right side thereof.  
The broken lines are included for the purpose of illustrating portions of the autoclave that form no part of the claimed design.

**1 Claim, 4 Drawing Sheets**

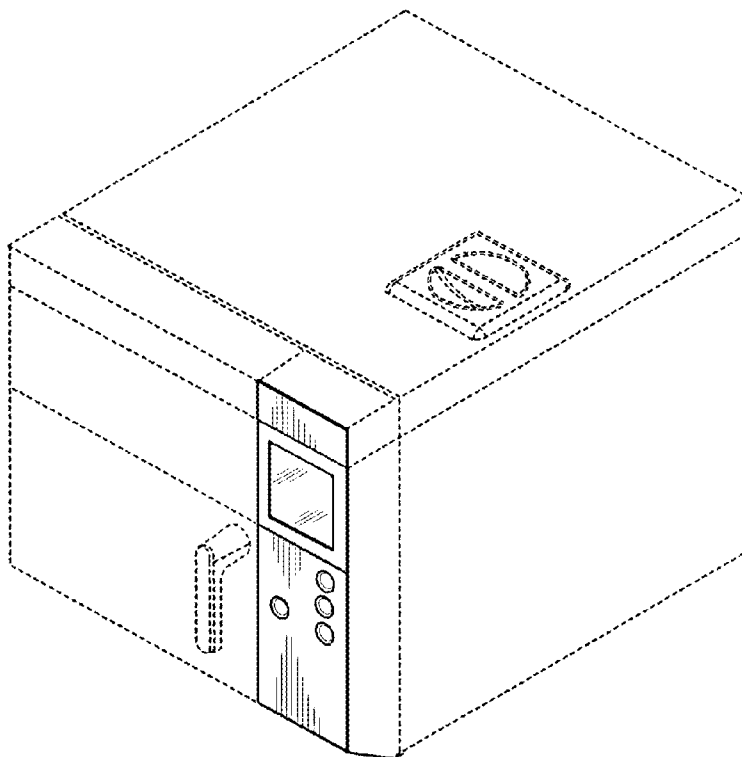

FIG. 1

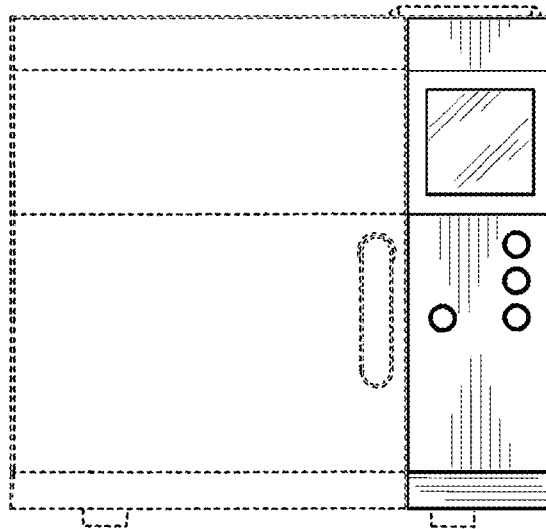

FIG. 2

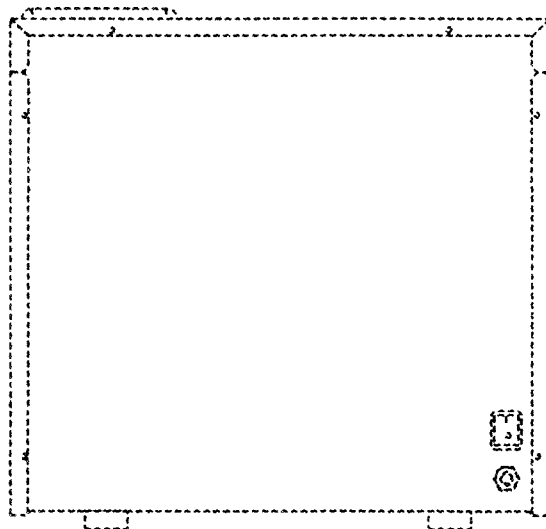

FIG. 3

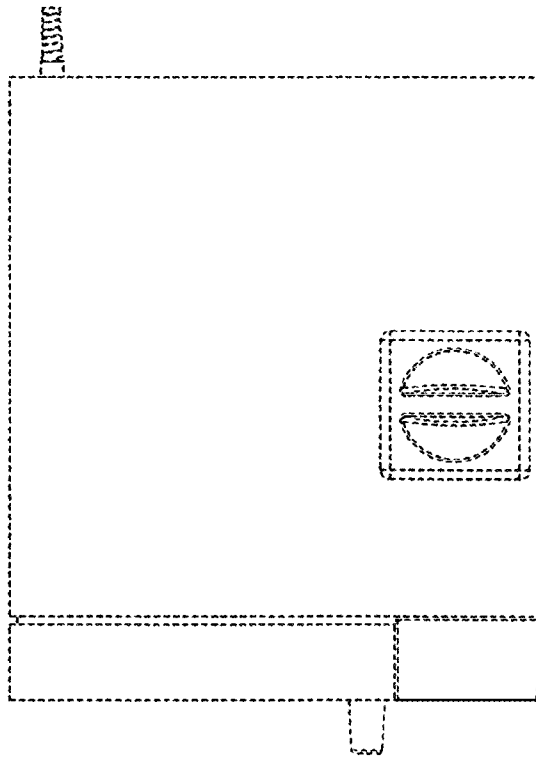

FIG. 4

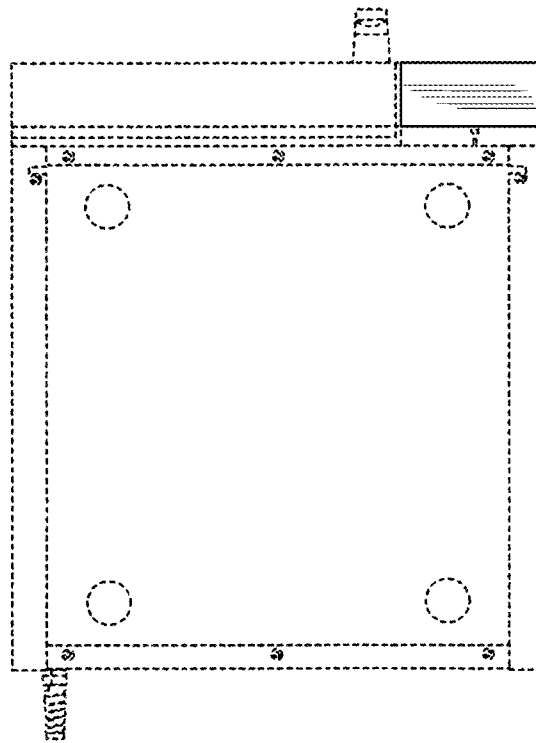

FIG. 5

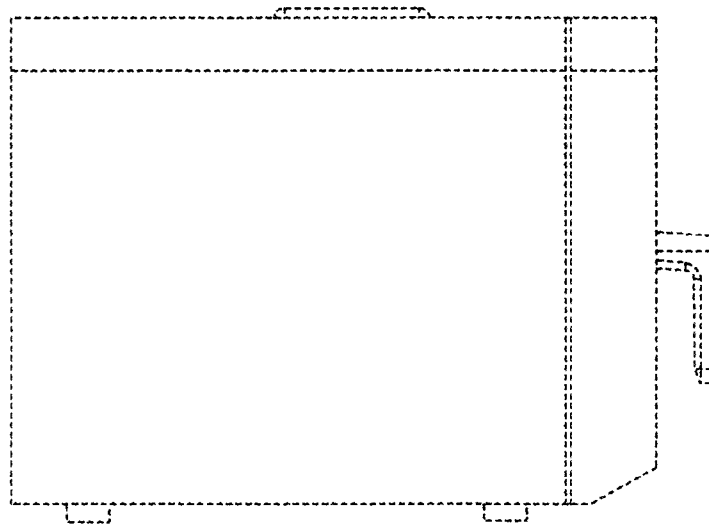

FIG. 6

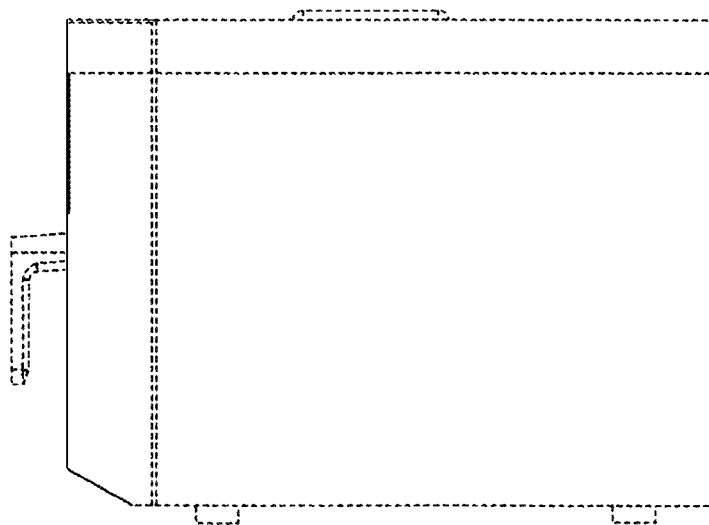

FIG. 7

