

[72] Inventor **John Ernest Lewin**
London, England

[21] Appl. No. **862,421**

[22] Filed **Sept. 30, 1969**

[45] Patented **Dec. 28, 1971**

[73] Assignee **National Research Development Corporation**
London, England

[32] Priority **Oct. 31, 1968**

[33] **Great Britain**

[31] **51,738/68**

[50] Field of Search..... 340/240,
 279; 5/348; 128/2

[56] **References Cited**

UNITED STATES PATENTS

3,325,799 6/1967 Farris 340/279

Primary Examiner—John W. Caldwell
Assistant Examiner—Daniel Myer
Attorney—Cushman, Darby and Cushman

[54] **APNOEA ALARMS**
4 Claims, 4 Drawing Figs.

[52] U.S. Cl..... **340/240,**
5/348

[51] Int. Cl..... **G08b 21/00,**
A47c 27/08

ABSTRACT: An apnoea alarm comprises a compartmented air mattress the individual compartments of which are connected to a common chamber containing an anemometer. The anemometer is connected to an electronic circuit which gives an alarm after a preset time if there is no airflow over the katherometer due to movement of the mattress caused by a breathing baby lying on it.

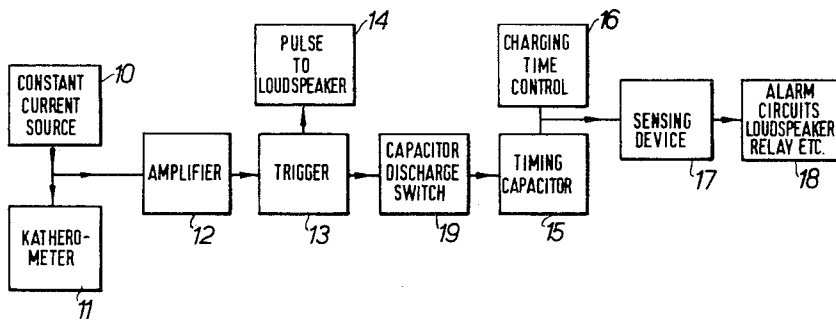

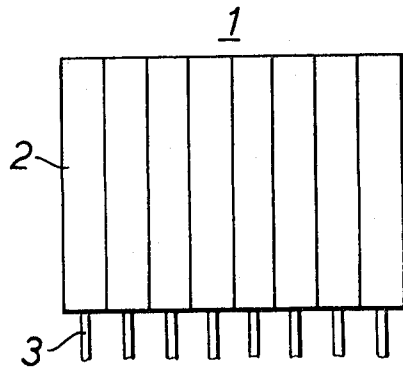

FIG. 1.

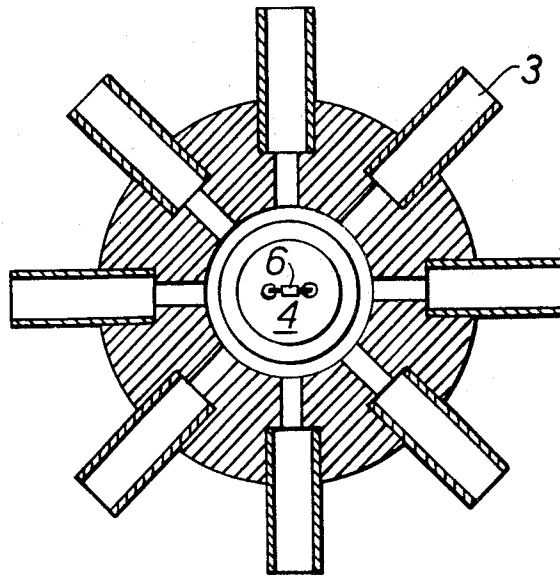

FIG. 3.

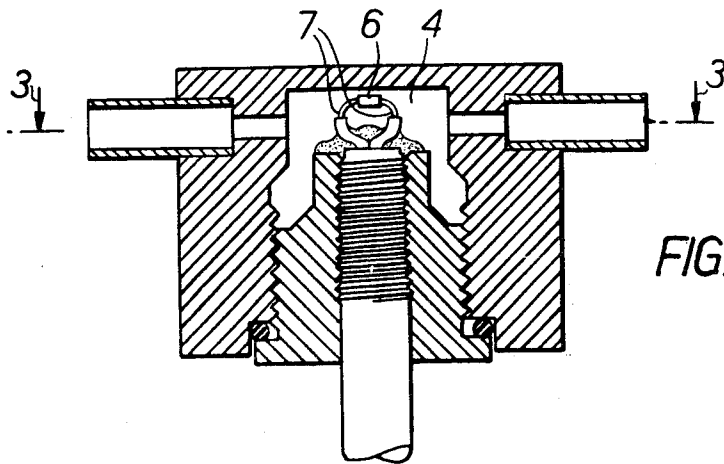

FIG. 2.

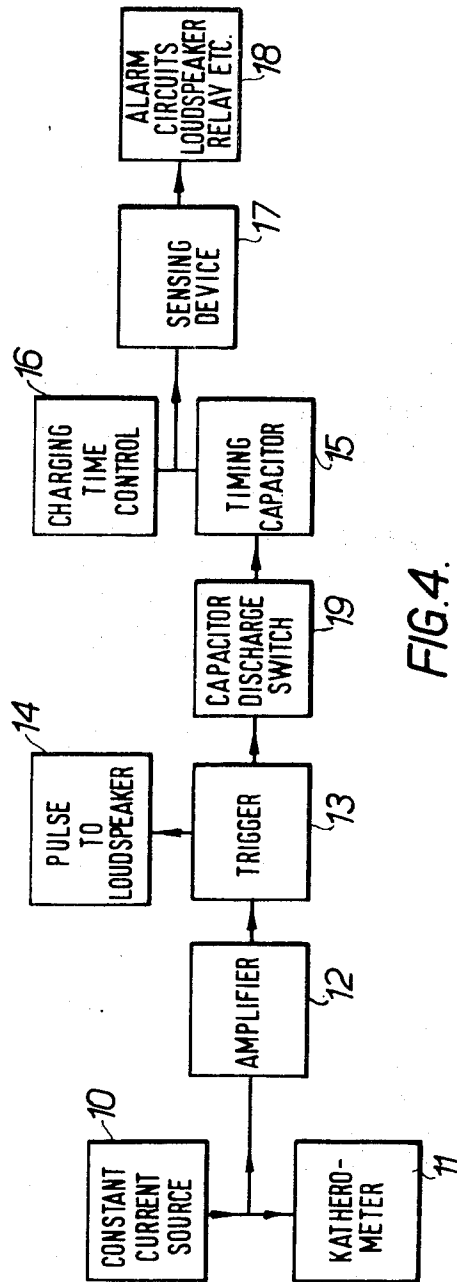

FIG. 4.

APNOEA ALARMS

This invention relates to apnoea alarms. Apnoea is a condition in some newborn babies in which breathing ceases unexpectedly. It is important to take immediate remedial action when this occurs and it is an object of the invention to provide an alarm for indicating this condition.

According to the invention an apnoea alarm comprises a mattress, means for detecting differential compression of the mattress, a sensory alarm, and a switch for operating the alarm in the absence of compression of the mattress after a preset time period from a previously detected compression.

In carrying out the invention, the mattress may comprise an air mattress divided into a plurality of separate compartments each having a ducted outlet and the detection means may comprise an anemometer for detecting airflow in any of the ducted outlets.

In a preferred arrangement the ducted outlets are connected to a common chamber in which the katherometer is positioned and the anemometer preferably comprises a thermistor. Sensory indication different from the alarm may also be given of the compression of the mattress within a preset period so that a ready check can be made of the breathing of the baby and the functioning of the alarm.

In order that the invention may be more fully understood reference will now be made to the accompanying drawing in which:

FIG. 1 illustrates a mattress forming a part of the apnoea alarm,

FIG. 2 is a sectional elevation of an anemometer included in the alarm,

FIG. 3 is a cross section of the anemometer along the line 3-3, and

FIG. 4 is a block circuit diagram of the electrical compartments of the alarm.

Referring now to FIG. 1 the apnoea alarm includes an air mattress 1 divided into a number of separate compartments 2 each having a ducted outlet such as 3. All the ducted outlets are connected to a common chamber 4 (see FIGS. 2 and 3) in which the outlets are directed to the center thereof like the spokes of a wheel. At the center there is positioned an anemometer which comprises a thermistor bead 6 having a pair of electrode leads 7.

Mattress 1 is used as the mattress of the incubator or cot on which the baby lies and it has been found in practice that the effect of the breathing of the baby causes rhythmic differential compression of the mattress in time with the breathing and

causes airflow along the ducts 3. This airflow is directed to pass over the thermistor bead 6 and produces a cooling effect therein, which, if a constant current is passed through bead 6, causes measurable changes in voltage in synchronism with the breathing of the baby.

The circuits for detecting this change in voltage are shown in FIG. 4 and comprise a constant current source 10 which feeds the anemometer shown diagrammatically as block 11. The voltage across the anemometer is amplified in an amplifier 12 and operates a trigger circuit 13. The trigger pulses produced by trigger circuit 13 can be directly monitored by a loudspeaker 14 to give a "click" sound at each breath of the baby. The gain of amplifier 12 can be adjustable to allow for different babies' weights and depths of respiration.

The alarm circuit comprises a timing capacitor 15 which can be charged at a preset rate as controlled by a charging circuit 16 and when the voltage across timing capacitor 16 reaches a reference or supply voltage the charging current ceases and this is monitored by a sensing device 17 which then operates alarm circuits. These alarm circuits may comprise a bell, buzzer, lights or other sensory indicators. It will be seen in the absence of any discharge of capacitor 15 alarm circuits 18 will operate at a predetermined time after commencement of charge as set by the charging circuit 16. Should a trigger pulse be received from trigger circuit 13 within that time it operates a discharge switch 19 to discharge timing capacitor 15 and thus causes the timing cycle to recommence again.

I claim:

1. An apnoea alarm system comprising an air mattress having a plurality of separate compartments, air-connection means between said compartments, means for detecting differential changes in compression between different ones of said compartments, a sensory alarm, and

a switch for operating the alarm in the absence of any change in compression of the mattress after a preset time period from a last detected change in compression.

2. The alarm system as claimed in claim 1 in which said air-connection means comprises a ducted outlet to each of said compartments and air connections between all said ducted outlets and in which the detection means comprises an anemometer for detecting airflow in any of the ducted outlets.

3. The alarm as claimed in claim 2 in which the ducted outlets are connected to a common chamber in which the anemometer is positioned.

4. The alarm as claimed in claim 2 in which the anemometer comprises a thermistor.

* * * * *

50

55

60

65

70

75