

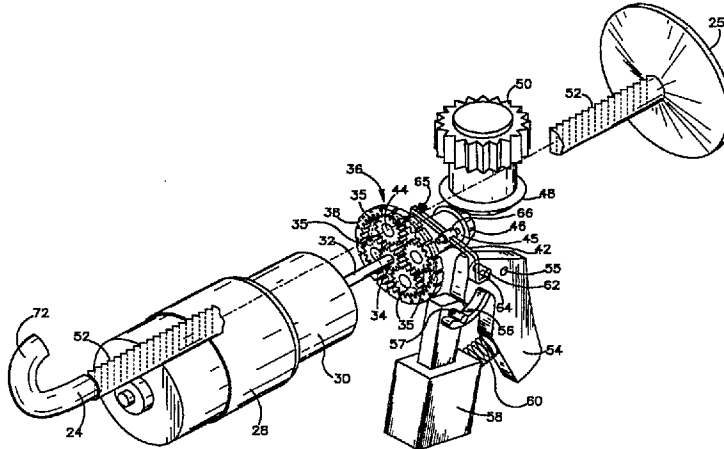

- (72) BATES, Darryle E., US
(72) KALANISH, Scott S., US
(71) Essex Specialty Products, Inc., US
(51) Int.Cl.⁶ B05C 17/01
(30) 1995/05/05 (08/435,343) US
(54) **PROCEDE ET PISTOLET DE DISTRIBUTION DE MATIERES, A
COMMANDE ELECTRIQUE**
(54) **ELECTRICALLY OPERATED MATERIAL DISPENSING GUN
AND METHOD**



(57) L'invention concerne un pistolet de distribution de matières (10), à commande électrique, comprenant un corps doté d'une partie poignée (11) et d'une partie support (12) de cartouche allongée s'étendant vers l'extérieur de la partie poignée (11). La partie support de cartouche (12) présente un espace de support de cartouche et une paroi d'extrémité ouverte (15) destinée à recevoir une buse de distribution de matière à cartouche et à venir en contact, à l'encontre de la force de distribution, avec une extrémité de distribution d'une cartouche placée dans l'espace. Un poussoir à mouvement alternatif (24) est porté par la partie poignée

(57) An electrically actuated material dispensing gun (10) is disclosed having a body including a handle section (11) and an elongate cartridge support section (12) extending outwardly from the handle section (11). The cartridge support section (12) includes a cartridge support space and an apertured end wall (15) for receiving a cartridge dispensing nozzle and for dispensing force resisting engagement with a dispensing end of a cartridge positioned in the space. A reciprocating push rod (24) is carried by the handle section (11) and axially aligned with the space for force transmitting engagement with a piston (25) which in one



(11) et aligné axialement avec l'espace pour venir en contact de transmission de force avec un piston (25) qui, dans un mode de réalisation, est de construction unique. Un moteur électrique (28) est monté dans la partie poignée (11). Un élément d'entraînement (50) est monté rotatif dans la partie poignée (11) et, en mode d'entraînement direct, est relié mécaniquement au poussoir (24). L'élément d'entraînement (50) se met normalement en rotation libre en réponse à un déplacement axial du poussoir (24). Une transmission (36) comprenant un engrenage planétaire est reliée à l'arbre de sortie du moteur (28). Dans un mode de réalisation, un embrayage de transmission est prévu pour accoupler automatiquement entre eux l'élément d'entraînement (50) et la transmission (36) et pour transmettre les forces d'entraînement lorsqu'ils sont ainsi accouplés et lorsque l'arbre de sortie est mis en rotation en réponse à l'excitation du moteur. Dans un autre mode de réalisation, un piston à commande manuelle complète sélectivement la transmission. Une gâchette (54) est prévue sur la partie poignée (11) et est accouplée de manière fonctionnelle à un interrupteur marche/arrêt (58) pour compléter sélectivement un circuit d'excitation de moteur. Par ailleurs, la gâchette (54) agit conjointement avec l'embrayage pour induire l'accouplement de l'engrenage planétaire (36) et de l'élément d'entraînement (50) lorsque le moteur (28) est excité.

embodiment is of unique construction. An electric motor (28) is mounted in the handle section (11). A drive element (50) is rotatively mounted in the handle section (11) and in positive drive, mechanically interconnected, relationship with the rod (24). The drive element (50) is normally freely rotatable in response to axial motion of the rod (24). A power train (36) including a planetary is connected to the output shaft of the motor (28). In one embodiment a drive transmission clutch is provided for automatically interconnecting the drive element (50) and the power train (36) and for transmission of driving forces when so interconnected and when the output shaft is rotated in response to motor energization. In another embodiment a manually actuated plunger selectively completes the drive train. A trigger (54) is carried by the handle section (11) and is operably connected to an on/off switch (58) selectively to complete a motor energization circuit. The trigger (54) also coacts with the clutch to cause such automatic interconnection of the planetary (36) and the drive element (50) when the motor (28) is energized.



PCT

WORLD INTELLECTUAL PROPERTY ORGANIZATION
International Bureau

INTERNATIONAL APPLICATION PUBLISHED UNDER THE PATENT COOPERATION TREATY (PCT)

(51) International Patent Classification ⁶ : B05C 17/01	A1	(11) International Publication Number: WO 96/34696 (43) International Publication Date: 7 November 1996 (07.11.96)
(21) International Application Number: PCT/US96/06302 (22) International Filing Date: 3 May 1996 (03.05.96) (30) Priority Data: 08/435,343 5 May 1995 (05.05.95) US (60) Parent Application or Grant (63) Related by Continuation US 08/435,343 (CIP) Filed on 5 May 1995 (05.05.95) (71) Applicant (for all designated States except US): AMERITOOOL CORPORATION [US/US]; 16741 West Park Circle, Chargin Falls, OH 44022 (US). (72) Inventors; and (75) Inventors/Applicants (for US only): BATES, Darryle, E. [US/US]; 1592 Redwing Trail, Stow, OH 44224 (US). KALANISH, Scott, S. [US/US]; 18087 Rapids Road, Hiram, OH 44234 (US). (74) Agent: FISHER, Thomas, E.; Watts, Hoffmann, Fisher & Heinke Co., L.P.A., P.O. Box 99839, Cleveland, OH 44199-0839 (US).		(81) Designated States: AL, AM, AT, AU, AZ, BB, BG, BR, BY, CA, CH, CN, CZ, DE, DK, EE, ES, FI, GB, GE, HU, IS, JP, KE, KG, KP, KR, KZ, LK, LR, LS, LT, LU, LV, MD, MG, MK, MN, MW, MX, NO, NZ, PL, PT, RO, RU, SD, SE, SG, SI, SK, TJ, TM, TR, TT, UA, UG, US, UZ, VN, ARIPO patent (KE, LS, MW, SD, SZ, UG), Eurasian patent (AM, AZ, BY, KG, KZ, MD, RU, TJ, TM), European patent (AT, BE, CH, DE, DK, ES, FI, FR, GB, GR, IE, IT, LU, MC, NL, PT, SE), OAPI patent (BF, BJ, CF, CG, CI, CM, GA, GN, ML, MR, NE, SN, TD, TG). Published <i>With international search report.</i> <i>Before the expiration of the time limit for amending the claims and to be republished in the event of the receipt of amendments.</i>

(54) Title: ELECTRICALLY OPERATED MATERIAL DISPENSING GUN AND METHOD**(57) Abstract**

An electrically actuated material dispensing gun (10) is disclosed having a body including a handle section (11) and an elongate cartridge support section (12) extending outwardly from the handle section (11). The cartridge support section (12) includes a cartridge support space and an apertured end wall (15) for receiving a cartridge dispensing nozzle and for dispensing force resisting engagement with a dispensing end of a cartridge positioned in the space. A reciprocable push rod (24) is carried by the handle section (11) and axially aligned with the space for force transmitting engagement with a piston (25) which in one embodiment is of unique construction. An electric

motor (28) is mounted in the handle section (11). A drive element (50) is rotatively mounted in the handle section (11) and in positive drive, mechanically interconnected, relationship with the rod (24). The drive element (50) is normally freely rotatable in response to axial motion of the rod (24). A power train (36) including a planetary is connected to the output shaft of the motor (28). In one embodiment a drive transmission clutch is provided for automatically interconnecting the drive element (50) and the power train (36) and for transmission of driving forces when so interconnected and when the output shaft is rotated in response to motor energization. In another embodiment a manually actuated plunger selectively completes the drive train. A trigger (54) is carried by the handle section (11) and is operably connected to an on/off switch (58) selectively to complete a motor energization circuit. The trigger (54) also coacts with the clutch to cause such automatic interconnection of the planetary (36) and the drive element (50) when the motor (28) is energized.

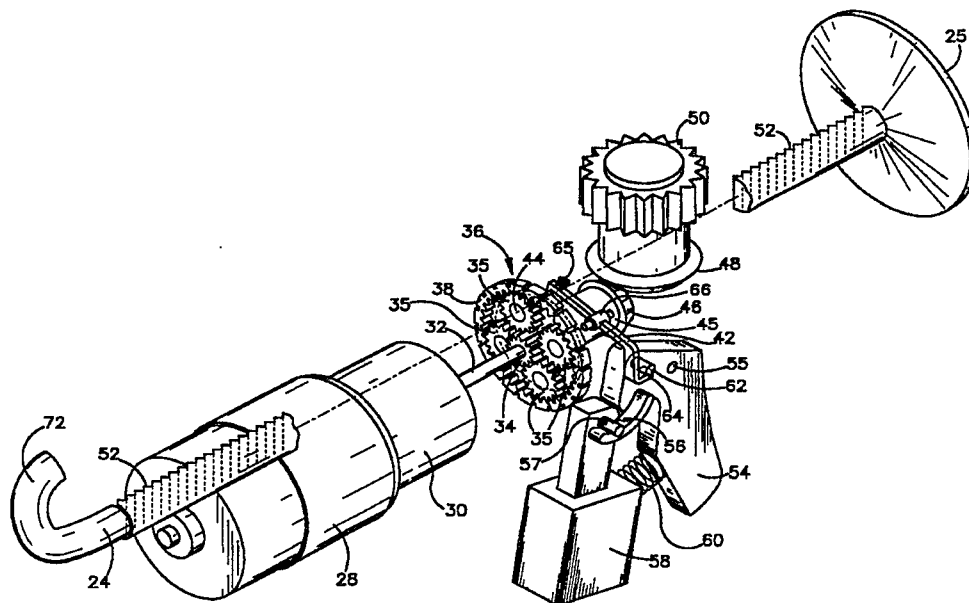

ELECTRICALLY OPERATED MATERIAL DISPENSING GUN AND METHOD

Technical Field

This invention relates to viscous material dispensers and more particular to a material dispensing gun adapted to receive a disposal tube of viscous material and having a battery operated electric motor as a power source for dispensing the material.

Background

The use of disposable cartridges of caulking material is not only now well established but has become the near universal system for the dispensing of caulking compounds, various sealants and other viscous materials. While hand actuated caulking guns are well known and well established, for a variety of reasons there is a growing demand for powered caulking guns.

Professionals, such as those employed in the construction trade, can suffer excessive fatigue from performing tasks such as applying adhesives to joists and studs when sheet flooring or wall boards are being installed. Indeed, the use of hand actuated caulking guns for such tasks can result in injuries such as carpal tunnel syndrome.

Automobile windshields represent another reason there is a demand for power assisted caulking guns. With many current automotive designs, the windshields have become structural parts of automobiles. In order for a windshield to function as a structural part, a windshield is securely bonded to a surrounding metal frame. The adhesive materials used for this windshield bonding have high viscosity, and dispensing such an adhesive from a cartridge requires extremely high dispensing forces. As a consequence, the installation of such windshields requires a material dispensing gun with which significant force is applied to the material to cause its dispensing.

Air actuated caulking guns which utilize compressed air are known. One commercially successful air actuated gun is described in United States Patent 5,181,636 issued January 26, 1993 under the title Incremental Dispensing Device and assigned to the assignee of this patent. Most notably the embodiment shown in Figures 4 through 7 of that patent has enjoyed good success in such applications as the dispensing of adhesives on joists for securement of subflooring. While this air actuated gun has enjoyed success, attempts to provide truly portable battery powered caulking guns have enjoyed only limited success.

One problem limiting the success of battery operated guns is the failure adequately to deal with a caulking material performance characteristic known to some as "after ooze". Typically caulking material and other adhesives will contain entrained air or other gases. When dispensing pressure of a caulking gun is stopped, the material being dispensed tends to continue to flow because the entrained gas is under pressure that must be relieved. This means that the pressure applied to a material tube piston should be released so that the expansion of the material being dispensed will be rearward, rather than through the outlet. When the tube piston is allowed to move freely rearwardly, the after ooze problem does not manifest itself, or at least is minimized. With battery operated guns provision for such rearward travel has not been provided other than by reversing the battery driven motor.

With most caulking guns, a rod or equivalent dispensing mechanism engages a piston of a caulking tube cartridge and drives the piston toward the outlet to expel viscous material from the cartridge. Once the material in a cartridge has been expended, it is desirable for the operator to very quickly retract the dispensing mechanism to enable a spent cartridge to be removed from the gun and a new cartridge to be inserted in it. Another shortcoming of prior proposals for battery operated guns is that no prior proposal has had a construction which provided truly simple and quick retraction of a dispensing mechanism.

Applications in which prior battery operated caulking guns could be utilized have been limited by the dispensing forces that could be generated. As an example, prior battery operated guns were not capable of generating sufficient force to dispense the sealants used to fix an automotive windshield to its surrounding metal frame.

A number of proposals have utilized a threaded rod as the mechanism to transmit expelling force to a viscous material cartridge piston. With a number of these it has been proposed that the threaded rod be engaged by a split nut or claw. With these proposals a manually actuated member would be provided to shift the nut components between a rod engaged position for dispensing and a rod release position for rod retraction.

With another proposal a cam would drive an elongate washer which would frictionally engage a dispensing rod when dispensing force is applied to the washer by the cam. This proposal suggests provision of a manually operated release screw for selective release of the washer, referred to by a patentee as a "holding plate", to allow manually retraction of the rod.

In another proposal, a toothed rod is provided which has a smooth surface over a large portion of its circumference. Drive and hold detents engage the rod teeth when the rod is being advanced. For retraction the rod is rotated until a smooth surface engages the detents to allow retraction.

With other proposals it has been necessary to have a reversible motor and to drive the motor in a reverse direction for drive mechanism retraction. Still another proposal would use a plug to expand an expansible threaded element into engagement with the drive gear when the tube is advanced and to release the tube from the gear for manual retraction.

A commercially available battery operated caulking gun utilizes collapsing racks to provide a relatively short gun. Retraction of the collapsing racks for replacing a spent cartridge with a fresh cartridge requires the application of a substantial manually applied pressure after a spent cartridge has been manually removed from the gun. To enable such removal, the

cartridge holding portion of the gun includes a pivotal end cover. The cover is selectively positionable in an overlapping relationship with the end of a caulking tube in a use position and pivotal to a retract position to allow extraction of a spent tube from the gun. Thus, there is no provision for collapsing the racks relatively in preparation of the gun for receiving a new cartridge unless the spent cartridge is first removed. Accordingly, there is, as compared with other modern caulking guns, undue complexity for the cartridge retention function.

Significantly, apart from the utilization of reversible motors to drive the dispensing mechanism away from the material being dispensed, none of the prior proposed battery operated caulking guns has, so far as has been determined, any provision for dealing with the "after ooze" problem unless the viscous material cartridge itself has provision for dealing with after ooze. In short, prior proposed battery actuated caulking guns have no provision for the abrupt cessation of viscous material dispensing when the application of dispensing force is terminated.

Summary of the Invention

An electrically actuated caulking gun made in accordance with this invention includes a housing having a handle section and an elongate cartridge support section. The cartridge support section extends outwardly from the handle section and is adapted to receive and support a cartridge of viscous material to be dispensed. The cartridge typically has a nozzle which projects through an opening in an end wall of the support section such that the dispensing end of the cartridge engages the wall to resist dispensing forces applied to a piston within the cartridge.

An elongate rod extends through the handle section and extends axially into the cartridge section. The rod has rack teeth formed in it. A rack pinion gear is rotatively mounted in the handle section in constantly meshing engagement with the rack teeth.

An epicyclic or planetary gear train is provided which includes a set of planet gears engaging a surrounding externally notched ring gear. A spider is connected to the planet gears to provide a planetary output. Constantly meshing gearing interconnects the rack pinion and the spider.

An electric motor is mounted in the housing. The motor is connected to the planetary via a high reduction gear box. An output of the gear box is toothed. The teeth of the output serve as a sun gear to constantly engage the planet gears.

A trigger is pivotally mounted in the handle section. On manual shifting of the trigger from a normal to an actuating position, an on/off, variable speed switch is actuated. Actuation of the switch closes a motor energizing circuit connecting the output of a handle section supported battery with the motor. Ideally the switch is of the now well known type which provides variable speed motor operation. The use of variable speed enables very precise operator control of viscous material dispensing rates.

In one embodiment, the trigger is linkage connected to a pawl. Movement of the trigger, causing energization of the motor, concurrently shifts the pawl into engagement with the ring gear. When the pawl becomes aligned with one of the ring gear notches, as a consequence of pawl engagement with the ring gear and ring gear rotation, the pawl is biased into the aligned notch to arrest the ring gear rotation. Arresting of the ring gear rotation causes the planet gears to orbit, rather than simply rotate about their own axes, and drive the output spider to in turn drive the rack. As the rack is driven toward the end wall of the cartridge support section, pressure is applied to a cartridge piston to expel viscous material through the cartridge nozzle.

One of the outstanding features of the thus far described embodiment of the invention is that at times other than when the motor is energized and the pawl engages the ring gear to stop its rotation, the rack is freely moveable. The rack is freely moveable because the ring gear is free to rotate relative to the motor, the gear box and the sun gear. Thus, if the rack is moved

rearwardly away from the cartridge support end wall, whether it be by manual retraction force or in response to pressure from air entrained in the viscous material expanding at the conclusion of the application of material dispensing force and, since the ring gear is free to rotate, the planetary train and spider rotate freely without rotation of components of either the motor or the high reduction gear box.

Where exceptionally viscous materials are to be dispensed, a modified ring gear and a spring biased plunger are provided for enhanced strength in selectively establishing force transmissions control of connections between the planetary and the racks. A manually operated over center plunger positioner is provided to selectively fix the plunger in a release position or permit the plunger to be spring biased into engagement with the modified ring gear.

Among other advantages free rack movement enables quick exchange of an unused cartridge of material for a spent cartridge. This feature is especially advantageous if the operator is placing a partially spent cartridge in the gun because it is not necessary to drive the dispensing mechanism slowly forward with the motor.

Another advantage of the provision of a freely moveable rack is that not only can the dispensing mechanism be retracted quickly, it is done manually. In the case of the pawl embodiment, this permits the use of a relatively inexpensive unidirectional motor circuit rather than a more expensive reversible motor circuit.

A novel piston provides exceptionally efficient dispensing when the material to be dispensed is in a bag like container.

Accordingly, the objects of the invention are to provide a novel and improved electrically actuated viscous material dispenser and a method of dispensing viscous material.

Brief Description of the Drawings

Figure 1 is a sectional view of the caulking gun of this invention with the cartridge support section foreshortened for clarity of illustration;

Figure 1A is an end elevational view of the cartridge support section end wall;

Figure 2 is a perspective view of the motor, the rack and the drive train interposed between the two;

Figure 3 is an enlarged sectional view showing the planetary in its normal condition;

Figure 4 is a view corresponding to Figure 3 but showing the pawl engaged with a notch of the ring gear to place the planetary in a rack driving position;

Figures 5 and 6 are partially sectioned elevational views of the enhanced strength force transmission control; and,

Figure 7 is an enlarged sectional view of a piston.

Detailed Description and Preferred Embodiment

Referring now to the drawings and to Figure 1 in particular, an electrically actuated caulking gun is shown generally at 10. the drawing is somewhat schematic for clarity of illustration. The gun 10 includes a housing having a handle section 11 and a cartridge support section 12. In Figure 1, the illustrated cartridge support section includes an end wall 15 having a nozzle receiving slot 16. Alternatively, a threadably removable support section as is known in the art may be provided and indeed is preferred in some applications such as sausage dispensing and windshield repair as depicted in Figure 7.

Cartridges containing viscous material to be dispensed, one of which is shown in phantom at 18 in Figure 1, are selectively positionable in a cartridge receiving space delineated by the support section 12. A typical cartridge 18 includes a nozzle 20 which projects through the slot 16 such that a forward end 22 of the cartridge abuts the end wall 15 to provide resistance against material dispensing applied forces.

An elongate rod 24 projects axially through an upper portion of the handle section 11 and into the cartridge receiving space in the support section 12. A pusher 25 is connected to the rod 24 at its forward or distal end for selective engagement with a cartridge piston 26.

An electric motor 28 is mounted within the handle section 11. For clarity in the schematic showing of Figure 1, the motor is shown as in a rearward extension of the handle section rather than within it. Preferably the motor is selected to operate under load at 85% to 90% of its no load speed. Such operation avoids surges such as are exhibited by other guns when a trapped air pocket is reached. Such operation also provides suitable dispensing speeds with highly viscous materials.

As is best shown in Figures 3 and 4, a motor output shaft, not shown, is connected to gears within a high reduction gear box 30. An output shaft 32 of the gear box 30 carries a drive pinion or sun gear 34. The sun gear 34 is in constantly meshing engagement with a set of four planet gears 35 of a planetary train shown generally at 36. The planetary train 36 includes a ring gear 38 which surrounds and constantly engages the planet gears 35. The ring gear 38 of Figures 2 - 4 includes a plurality of external notches 40. The notches are selectively engageable by a pawl 42.

The planet gears 35 are respectively journaled on support shafts 44. The support shafts 44 are connected to a planet carrier and shaft which in turn is connected to a spider 45, see Figure 2. The spider 45 includes a bevel gear 46 which constantly meshes a mating bevel gear 48. The bevel gear 48 drives a rod pinion 50. The rod pinion 50 is in constantly meshing engagement with rack teeth 52 formed in the rod 24.

A trigger 54 is carried by the handle section 11 via a pivot 55. An arm 56 is carried by the trigger. The arm 56 has an aperture which receives a control arm 57 of a variable speed control, switch 58. One suitable switch is supplied by Lucerne Products, Inc. of Hudson, Ohio utilizing the circuitry of its TSCRDC-2512 switch in a pivotal trigger ELM-2516-LBS switch. A trigger

spring 60 biases the trigger 54 toward its normal or off position. Due to the control arm 57 of the switch 58 being within the aperture in the trigger arm 56, the spring 60 also biases the switch to a normally off condition.

In the embodiment of Figures 2 - 4, a pawl arm 62 projects laterally from the trigger 54. The pawl arm 62 engages a pawl projection 64. A spring 65 biases the pawl 42 about a pivot support 66 to maintain the pawl projection 64 in engagement with the pawl arm 62 when the trigger 54 is in its off position and to maintain the pawl in engagement with the ring gear when the trigger is depressed. The trigger spring 60 is stronger than the pawl spring 65, so that when the trigger is in its normal or off position, the pawl is biased to its normal position shown in Figure 3.

An enhanced strength force transmission control is shown in Figures 5 and 6. The enhanced control includes a modified ring gear 75 having a plurality of circumferentially spaced drive shoulders 76 formed in its perimetral surface. A plunger 78 is reciprocatably mounted in a cylindrical housing 79 secured in fixed relation to the remainder of the gun 10. A manually positionable over center lever 80 is pivotally connected to the plunger 78. A spring 82 biases the plunger toward the ring gear 75. The lever 80 has a ring gear release position as shown in Figure 6. When the lever 80 is in the ring gear release position the spring 82 is compressed and the plunger is recessed in the housing out of engagement with the ring gear 75.

When the lever 80 is moved to its drive position as shown in Figure 5, the spring 82 biases the plunger into circumferential engagement with the ring gear 75. As the ring gear rotates in a counterclockwise direction as viewed in Figure 5, the plunger will drop into a notch adjacent one of the drive shoulders 76 which functions as a ring gear rotation arresting stop. Once it comes into engagement with the one drive shoulder, rotation of the ring gear is arrested. Any further operation of the motor will then drive the rod 24, through coaction of the pinion and the rack teeth 50, 52, to dispense material. Thus the plunger

when in the drive position of Figure 5 enables the drive train to function while when it is in its release position of Figure 6 the drive train is disabled.

Referring now to Figure 7, an enlarged cross sectional view of the piston 25' and its connection to the rod 24 is shown. The piston 25' is a unitary plastic component preferably formed of Delrin. The piston 25' has a counterbore 86 extending axially inwardly from a rearward or driven side of the piston. The rod 24 includes a reduced diameter end portion 88. The diameter of the rod 88 is less than the diameter of the counterbore 86 to provide a clearance which is shown in exaggerated form in Figure 7. The rod 24 has an annular shoulder 89 surrounding the reduced diameter end portion 88 and abutting a rearwardly extending piston abutment 90 surrounding the counterbore 86.

A fastener in the form of a cap screw 91 is threaded into the reduced diameter end 88 of the rod 24. The cap screw 91 has a head positioned in a second counterbore 92 which is axial aligned with the counterbore 86 and extends inwardly from the opposite or face side of the piston. The shank of the cap screw extends through an axial aligned bore connecting the two counterbores 86, 92. Radial clearance is provided between the piston on the one hand and the piston rod and cap screw on the other to permit limited relative movement.

An annular, concave recess 94 is formed in the forward or face surface of the piston 25'. The annular recess surrounds a forwardly projecting central nose portion 95 of the piston 25'. The recess in turn is surrounded by an outwardly flaring, forwardly tapered, perimetral lip 96. The piston has an annular, perimetral skirt 97 adjacent its rear surface and spaced from the lip by a reduced diameter, central, perimetral surface. The lip 96 and the skirt 97 slidably engage a smooth internal wall of a surrounding tubular cartridge support section 98. The coaction of the outwardly flaring and deformable lip 96, together with the clearance between the piston and the reduced diameter end 88 and the cap screw, allows the piston to float somewhat relative to the

piston rod. Because of this relative floating and the deformability of the lip 96, the piston is able to effectively act against a collapsible cartridge 100 of the type used to house windshield repair adhesives.

Operation

When the gun 10 is to be used, a handle rod projection 72 is grasped by the operator and the rod 24 is pulled rearwardly until the pusher 26 engages the base of the cartridge support section 12. A cartridge 18 is inserted into the support section space and the rod is then pushed manually forward until the pusher engages the cartridge piston 26.

In the case of the heavy duty embodiment of Figures 5 and 6 employing the tubular cartridge support tube 98 the action is somewhat similar. The rod 24 is pushed manually to shift the piston 25' in a forward direction until engagement with the cartridge 100 is established. The manual advance followed by a power advance results in the piston aligning itself relative to the rod in a manner such that the lip 96 tightly engages the circumscribing wall of the tube 98.

On depression of the trigger 54 to move it from its normal to an on position, the control arm 57 of the switch 58 will move the switch to an on position. Once the switch is in an on position, a circuit is completed between a battery 68 and the motor 28 to energize the motor and cause it to rotate. Switch circuitry is so developed to linearly alter the supplied voltage to the motor, which resultingly controls the operational speed of the motor. Additionally, the switch incorporates a circuitry bypass at the full on position (full voltage) to preclude thermal buildup in the circuitry.

As the motor rotates, the sun gear 34 will be driven in a clockwise direction as seen and indicated in Figure 4. Rotation of the sun gear 34 causes the planet gears to rotate about their own axes in a counterclockwise direction as indicated by solid line arrows in Figure 3. This rotation of the planet gears in turn causes the ring gear 38 to rotate in a counterclockwise direction as is also indicated in Figure 3.

With the embodiment of Figures 2 -4 , when the trigger 54 is moved from its normal or off position to an on position, the pawl 42 will pivot about its axis 66 under the action of the pawl spring 65. This will cause a ring gear engaging projection 70 of the pawl 42 to engage the outer surface of the ring gear 38 and function as a clutch. Once one of the notches 40 in the ring gear is aligned with the projection 70, the pawl spring 65 will bias the projection into the aligned notch 40 as shown in Figure 4.

With the gun of the embodiment of Figures 5 and 6, the over center lever 80 is moved from the position of Figure 6 to the position of Figure 5. This results in the spring 82 biasing the plunger 78 against the circumference of the ring gear. On actuation of the trigger 54, the ring gear will be driven counterclockwise until the plunger engages one of the shoulders 76 as illustrated in Figure 5.

The pawl to notch engagement, or the plunger 78 to drive shoulder 76 engagement, stops ring gear rotation causing the planet gears to commence to orbit in a clockwise direction as indicated by the dotted arrows in Figure 4. This planet gear orbiting in turn causes the spider 45 to rotate also in a clockwise direction as indicated by arrows in Figure 4. Rotation of the spider 45 acting through the bevel gears 46, 48 causes the rod pinion 50 to rotate. Rotation of the rod pinion 50 drives the rod 24. In the embodiment of Figure 1, the rod 24 drives its pusher 25 axially of the cartridge support section and against the cartridge piston 26 to expel viscous material through the nozzle 20.

With the embodiment of Figures 5 - 7, the piston lip 96 works around the cartridge 100. Successful tests on a proposed windshield adhesive, baglike, cartridge having an aluminum foil outer skin have been conducted. As the piston 25' is advanced, the foil is collected in the annular recess 95 and a pleating action is effected on the foil tube as the piston is advanced until complete expulsion of the adhesive from the cartridge is achieved.

With either embodiment, the rate of material dispensing is controlled by varying the amount of trigger movement from its normal position toward a full

on position. Varying the trigger movement in turn varies the movement of the variable speed control switch.

With the embodiment of Figures 2 - 4, the angles of the engaging surfaces on pawl 70 and the notches are so designed that when a pre-determined maximum allowable torque (or dispensing force) of an engaged notch is exceeded, the pawl will be cammed out overcoming the spring load of spring 65 and disengaging the drive train.

When actuating pressure on the trigger 54 is terminated, the spring 60 will bias the trigger and pawl to their normal positions, lifting the pawl projection 70 out of the engaged notch 40. Movement of the trigger to its normal position also returns the switch 58 to its off condition.

With the heavy duty version of Figures 5 and 6, a conventional reversing switch 84, Figure 1, for reversing operation of the DC motor 28 is provided. In order to disengage the plunger 78 from an engaged drive shoulder 76 the motor 28 is momentarily operated in a reverse direction. The over center lever 80 is then moved from the Figure 5 engaged position to the Figure 6 disengaged position to pull the plunger into the housing 79 and allow the ring gear to rotate freely.

When the switch is in its off condition, and in the Figures 5 and 6 embodiment the plunger is in its Figure 6 position, the rod 24 can readily be manually shifted in either direction. To retract the rod 24 one simply grasps handle rod projection 72 and pulls the rod rearwardly. This causes the rod pinion to rotate oppositely so that the spider 45 through coaction of the bevel gears 46, 48 is driven in a counterclockwise direction causing the planet gears to orbit in a counterclockwise direction as indicated by the phantom arrows in Figure 3. At this juncture the ring gear freely rotates. Similarly, when dispensing pressure stops and the pawl 42 or the plunger 78, as the case may be, is disengaged from its coacting ring gear 38 or 75, pressure of entrapped air in the viscous material of the cartridge can expand pushing the pusher 25 and

the connected rod rearwardly causing the same counterclockwise rotation as will manual retraction of the rod.

Although the invention has been described in its preferred form with a certain degree of particularity, it is understood that the present disclosure of the preferred form has been made only by way of example and that numerous changes in the details of construction, operation and the combination and arrangement of parts may be resorted to without departing from the spirit and the scope of the invention as hereinafter claimed.

CLAIMS

1. An electrically actuated viscous material dispenser comprising:

a) a body including a handle section and a viscous material section connected to and extending outwardly from the handle section;

5 b) a reciprocable push rod carried by the handle section for force transmission to the material section;

c) an electric motor mounted in the handle section and including an output shaft;

d) a drive element rotatively mounted in the handle section and in positive drive mechanically interconnected relationship with the rod;

10 e) the drive element being rotatable in one direction to drive the rod toward the material section;

f) the drive element normally being freely rotatable in another direction opposite the one direction in response to retractive motion of the rod;

15 g) a power train axially aligned with and connected to the output shaft for transmission of driving force on rotation of the output shaft in response to motor energization;

20 h) a drive transmission means including a planetary and a first bevel gear in axial alignment with the power train, the transmission means also including a second bevel gear in meshing engagement with the first bevel, the gears having transverse axes, the transmission means being for interconnecting the drive element and the power train and for the transmission of driving forces when so interconnected and when the output shaft is rotated in response to motor energization; and

25 i) the drive transmission means being adapted to terminate the interconnection of the drive element and the power train when the output shaft is not rotating.

2. The dispenser of Claim 1 wherein a trigger is carried by the handle section and an on/off switch is operably connected to the trigger and movable to a closed position to complete a motor energization circuit in response to movement of the trigger from its normal to its actuating position.

PCT/US 96/06302
IPEA/US12 MAY 1997

16

3. The dispenser of Claim 2 wherein the trigger coacts with the drive transmission means to cause such interconnection.
4. The dispenser of Claim 3 wherein the interconnection and the motor energization occur substantially concurrently.
5. The dispenser of Claim 2 wherein the switch is a variable speed control switch.
6. The dispenser of Claim 2 wherein the interconnection of the drive element and the powertrain is automatically disconnected when the trigger is moved from its actuating to its normal position.
7. A process of dispensing viscous material from a cartridge including a tube surrounding the material, an output nozzle at a dispensing end of the cartridge, the process comprising:
 - a) placing the cartridge in a cartridge hold section of a viscous material dispensing gun;
 - b) manually advancing a dispensing rod including rack teeth toward the cartridge and concurrently causing a drive pinion to rotate and with it rotation of a ring gear and other components of a connected planetary;
 - c) continuing the manual rod advance until a pusher at a distal end of the rod engages the cartridge;
 - d) energizing an electric motor to cause the planetary components to rotate; and,
 - e) arresting rotation of the ring gear to cause motor produced forces to be transmitted to the rod to drive the pusher in a dispensing direction against the cartridge to dispense material.
8. The process of Claim 7 wherein the motor energization and ring gear arresting steps are performed substantially concurrently.

PCT/US96/06302
IPEA/US12 MAY 1997

17

9. The process of Claim 7 including the step of varying the motor energization to thereby vary the rate of material dispensing.
10. The process of Claim 7 wherein the ring gear rotation arresting step includes manually enabling a plunger to engage the ring gear prior to energizing the motor.
11. The process of Claim 10 further including the step of causing the plunger to engage a shoulder in a perimetral surface of the ring gear.
12. The process of Claim 7 further including the step of allowing the material to expand against the pusher to shift the pusher and rod in a direction opposite the dispensing direction.
13. An electrically actuated viscous material dispenser comprising:
- a) a body including a handle section and a viscous material section connected to and extending outwardly from the handle section;
 - b) a reciprocable push rod carried by the handle section for force transmission to the material section;
 - c) an electric motor mounted in the handle section and including an output shaft;
 - d) a drive element rotatively mounted in the handle section and in positive drive mechanically interconnected relationship with the rod;
 - e) the drive element being rotatable in one direction to drive the rod toward the material section;
 - f) a power train connected to the output shaft for transmission of driving force on rotation of the output shaft in response to motor energization;
 - g) a drive transmission means for interconnecting the drive element and the power train and for the transmission of driving forces when so interconnected and when the output shaft is rotated in response to motor energization;

h) the drive transmission means including a plunger selectively manually positionable one at a time in a drive disabling position and a drive enabling position, the enabling position being for establishing such interconnection of the drive element and the power train;

i) the drive element being freely rotatable in another direction opposite the one direction in response to retractive motion of the rod when the plunger is in its drive disabling position ; and,

j) the plunger being connected to an overcenter lever for shifting the plunger between its positions.

14. An electrically operated viscous material dispenser comprising:

a) a housing including body and handle portions for housing a motor and a motor control;

b) the housing also including a material dispensing portion extending from the body and handle portions, the dispensing portion including a material receiving space;

c) an electric motor carried by the housing, the motor having an output shaft for rotation about a shaft axis;

d) a push rod reciprocatably mounted in the housing for extension into the space to apply a dispensing force to a material being dispensed, the rod being generally parallel to the output shaft and projecting rearwardly out of the housing in spaced relationship with the motor portion, the rod also including a set of rack teeth;

e) a planetary including a sun gear in axial alignment with and operably connected to the shaft for rotation about said axis, the planetary also including a ring gear and a set of planetary gears interposed between and engaging the sun and ring gears;

f) the ring gear being concentrically disposed about and coaxial with the sun gear, the ring gear also including a peripheral surface having at least one element engaging part;

g) gearing interconnecting the planet gears with the rack teeth in push rod drivable relationship; and,

PCT/US 9 6/ 06 3 0 2
MAY 1997

19

h) a moveable element carried by the housing and selectively engageable with the part to prevent ring gear rotation and thereby cause orbiting of the planet gears about the sun gear.

15. The dispenser of Claim 14 wherein said gearing includes a pair of orthogonally disposed and meshing bevel gears.

16. An electrically operated viscous material dispenser comprising:

- a) a housing including a motor space and a handle portion housing a motor control;
- b) the housing also including a material dispensing portion extending from the handle portion in a direction opposite the motor portion, the dispensing portion including a material receiving space;
- c) an electric motor at least partially within the motor portion, the motor having an output shaft extending toward the space for rotation about a shaft axis;
- d) a push rod reciprocatably mounted in the housing for extension into the space to apply a dispensing force to a material being dispensed, the rod being generally parallel to the output shaft and projecting rearwardly out of the housing in spaced relationship with the motor portion, the rod also including a set of rack teeth;
- e) a planetary including a sun gear drivingly connected to the shaft in axial alignment with the shaft, the sun gear being rotatable about said axis, the planetary also including a ring gear and a set of planetary gears interposed between and engaging the sun and ring gears;
- f) the ring gear being concentrically disposed about and coaxial with the sun gear, the ring gear also including a peripheral surface having at least one element engaging part;
- g) gearing interconnecting the planet gears with the rack teeth in push rod drivable relationship; and,

AMENDED SHEET

h) a moveable element carried by the housing and selectively engageable with the part to prevent ring gear rotation and thereby cause orbiting of the planet gears about the sun gear.

17. The dispenser of Claim 16 wherein the moveable element is manually actuable.

18. The dispenser of Claim 16 wherein said gearing includes a pair of orthogonally disposed and meshing bevel gears.

19. An electrically actuated viscous material dispenser comprising:

- a) a handle section;
- b) a viscous material section connected to the handle section;
- c) an electric motor carried by the handle section;
- d) a viscous material pressure supplying element adapted selectively to apply pressure to a quantity of viscous material carried by the material section;
- e) a power transmission means having a normal condition enabling free movement of the element between retracted and extended positions in response to manually applied forces and a drive condition disabling the free movement of the element;
- f) power drive condition enabling means for selectively energizing the motor to cause the power transmission to drive the element to apply pressure to such material when the transmission means is in its drive condition;
- g) said pressure supplying element comprising a push rod and a piston connected to the push rod; and,
- h) the piston comprising a unitary body of circular cross section including:
 - i) spaced face and back surfaces;
 - ii) an axial through bore extending between the surfaces;
 - iii) the bore including a spaced pair of counterbores, one of the counterbores extending from the back surface toward the face surface and the other from the face surface toward the back surface;

- iv) the one counterbore being for receipt of an end of the push rod;
- v) the back surface including a drive section circumscribing the bore and adapted to engage the push rod in force transmitting relationship;
- vi) the face surface including a nose section surrounding said counterbore and an annular concave recess section surrounding the nose section;
- vii) a perimetral surface extending axially from the face to the back surface; and,
- viii) the perimetral and face surfaces together defining a perimetral lip around the concave section, the lip being of tapering thickness tapering from its thickest part at a location nearest the back surface forwardly to a thin termination at a juncture of the face and perimetral surfaces.

20. The dispenser of Claim 19 wherein the lip flares outwardly in a direction from said location toward said juncture.
21. The dispenser of Claim 19 wherein the piston is a plastic piston.
22. The dispenser of Claim 21 wherein the plastic is Delrin.
23. The dispenser of Claim 19 wherein the drive section is the base of said one counterbore.
24. An electrically actuated viscous material dispenser comprising:
- a) a body including a handle section and a viscous material section connected to and extending outwardly from the handle section.
 - b) a reciprocable push rod carried by the handle section for force transmission to the material section;
 - c) an electric motor mounted in the handle section and including an output shaft;
 - d) a drive element rotatively mounted in the handle section and in positive drive mechanically interconnected relationship with the rod;

- 10 e) the drive element being rotatable in one direction to drive the rod toward the material section;
- f) a power train connected to the output shaft for transmission of driving force on rotation of the output shaft in response to motor energization;
- 15 g) a drive transmission means for interconnecting the drive element and the power train and for the transmission of driving forces when so interconnected and when the output shaft is rotated in response to motor energization;
- h) the drive transmission means including a plunger selectively manually positionable one at a time in a drive disabling position and a drive
- 20 enabling position, the enabling position being for establishing such interconnection of the drive element and the power train;
- i) the drive element being freely rotatable in another direction opposite the one direction in response to retractive motion of the rod when the plunger is in its drive disabling position; and,
- 25 j) a piston connected to the push rod, the piston comprising a unitary body of circular cross section including:
- i) spaced face and back surfaces;
- ii) an axial through bore extending between the surfaces;
- iii) the bore including a counterbore extending from the back
- 30 surface toward the face surface;
- iv) the counterbore receiving and surrounding an end of the push rod;
- v) the back surface including a drive section circumscribing the
- 35 bore and adapted to engage the push rod in force transmitting relationship;
- vi) the face surface including a nose section surrounding said bore and an annular concave recess section surrounding the nose section;
- vii) a perimetral surface extending axially from the face to the back surface; and,
- 40 viii) the perimetral and face surfaces together defining a perimetral lip around the concave section, the lip being of tapering thickness

tapering from its thickest part at a location nearest the back surface forwardly to a thin termination at a juncture of the face and perimetral surfaces.

25. The piston of Claim 24 wherein the lip flares outwardly in a direction from said location toward said juncture.

26. For use in a viscous material dispenser, a piston and push rod combination;

a) the piston comprising a unitary body of circular cross section

including:

i) spaced face and back surfaces;

5 ii) an axial through bore extending between the surfaces;

iii) the bore including a counterbore extending from the back surface toward the face surface;

iv) the face surface including a nose section surrounding said bore and an annular concave recess section surrounding the nose section;

10 vii) a perimetral surface extending axially from the face to the back surface; and,

viii) the perimetral and face surfaces together defining a perimetral lip around the concave section, the lip being of tapering thickness tapering from its thickest part at a location nearest the back surface forwardly to a thin termination at a juncture of the face and perimetral surfaces;

15

b) the push rod including an end portion engaging the piston; and,

c) a fastener connecting the piston to the push rod.

27. For use in a viscous material dispenser, a piston comprising a unitary body of circular cross section including:

a) spaced face and back surfaces;

b) an axial through bore extending between the surfaces;

5 c) the bore including a counterbore extending from the back surface toward the face surface;

d) the back surface including an annular drive section circumscribing the bore and adapted to engage a push rod in force transmitting relationship;

- 10 e) the face surface including a nose section surrounding said bore and
an annular concave recess section surrounding the nose section;
- g) a perimetral surface extending axially from the face to the back
surface; and,
- 15 h) the perimetral and face surfaces together defining a perimetral lip
around the concave section, the lip being of tapering thickness tapering from its
thickest part at a location nearest the back surface forwardly to a thin termination
at a juncture of the face and perimetral surfaces.
28. The piston of Claim 27 wherein the lip flares outwardly in a direction from
said location toward said juncture.
29. The piston of Claim 27 wherein the piston is a plastic piston.
30. The piston of Claim 29 wherein the plastic is Delrin.

- 10 d) the one counterbore receiving and surrounding a reduced diameter end of the push rod;
- e) the back surface including an annular drive section circumscribing the one counterbore and adapted to engage a shoulder of the push rod in force transmitting relationship;
- 15 f) the face surface including a nose section surrounding said other counterbore and an annular concave recess section surrounding the nose section;
- g) a perimetral surface extending axially from the face to the back surface; and,
- 20 h) the perimetral and face surfaces together defining a perimetral lip around the concave section, the lip being of tapering thickness tapering from its thickest part at a location nearest the back surface forwardly to a thin termination at a juncture of the face and perimetral surfaces.

44. The piston of Claim 43 wherein the lip flares outwardly in a direction from said location toward said juncture.

45. For use in a viscous material dispenser, a piston and push rod combination;

- a) the piston comprising a unitary body of circular cross section including:
- i) spaced face and back surfaces;
 - ii) an axial through bore extending between the surfaces;
 - iii) the bore including a spaced pair of counterbores, one of the counterbores extending from the back surface toward the face surface and the other from the face surface toward the back surface;
 - iv) the face surface including a nose section surrounding said other counterbore and an annular concave recess section surrounding the nose section;

v) a perimetral surface extending axially from the face to the back surface; and,

vi) the perimetral and face surfaces together defining a perimetral lip around the concave section, the lip being of tapering thickness tapering from its thickest part at a location nearest the back surface forwardly to a thin termination at a juncture of the face and perimetral surfaces;

b) the push rod including a reduced diameter end portion positioned in said one counterbore and a circumscribing shoulder for engaging the back surface of the piston; and,

c) a fastener connecting the piston to the push rod.

46. For use in a viscous material dispenser, a piston comprising:

a unitary body of circular cross section including:

a) spaced face and back surfaces;

b) an axial through bore extending between the surfaces;

c) the bore including a spaced pair of counterbores, one of the counterbores extending from the back surface toward the face surface and the other from the face surface toward the back surface;

d) the one counterbore being for receipt of a reduced diameter end of a push rod;

e) the back surface including an annular drive section circumscribing the one counterbore and adapted to engage a push rod shoulder in force transmitting relationship;

f) the face surface including a nose section surrounding said other counterbore and an annular concave recess section surrounding the nose section;

g) a perimetral surface extending axially from the face to the back surface; and,

h) the perimetral and face surfaces together defining a perimetral lip around the concave section, the lip being of tapering thickness tapering

from its thickest part at a location nearest the back surface forwardly to a thin termination at a juncture of the face and perimetral surfaces.

47. The piston of Claim 46 wherein the lip flares outwardly in a direction from said location toward said juncture.

48. The piston of Claim 46 wherein the piston is a plastic piston.

49. The piston of Claim 48 wherein the plastic is Delrin.

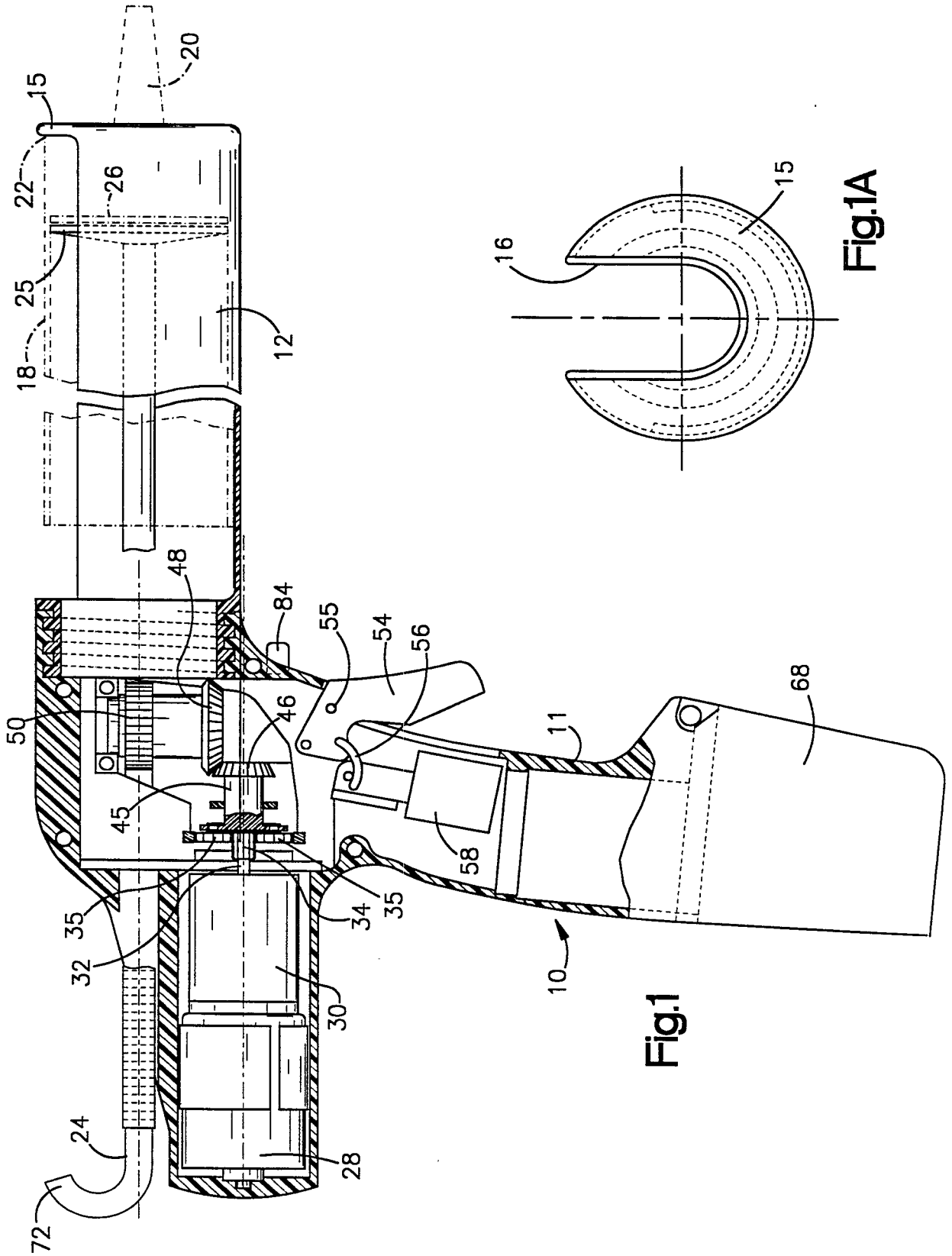

Fig.1

Fig.1A

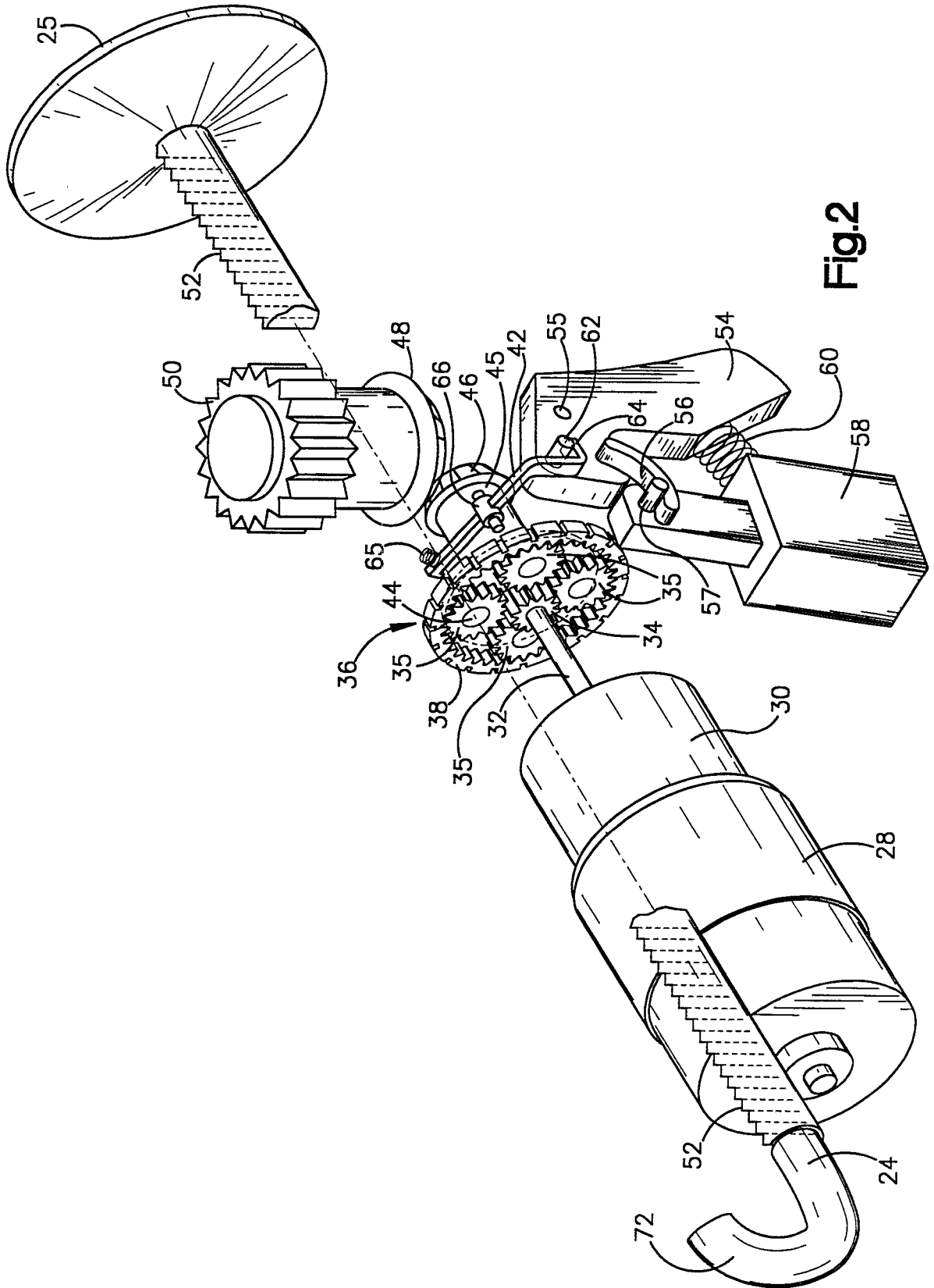
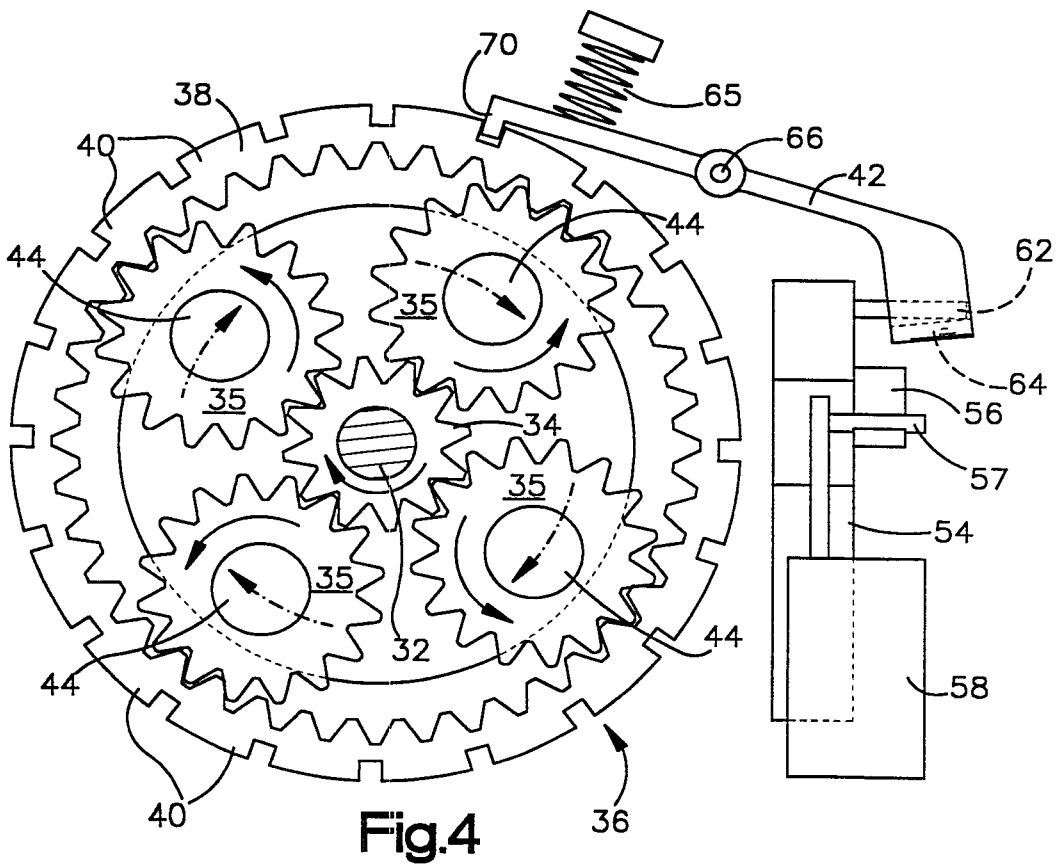
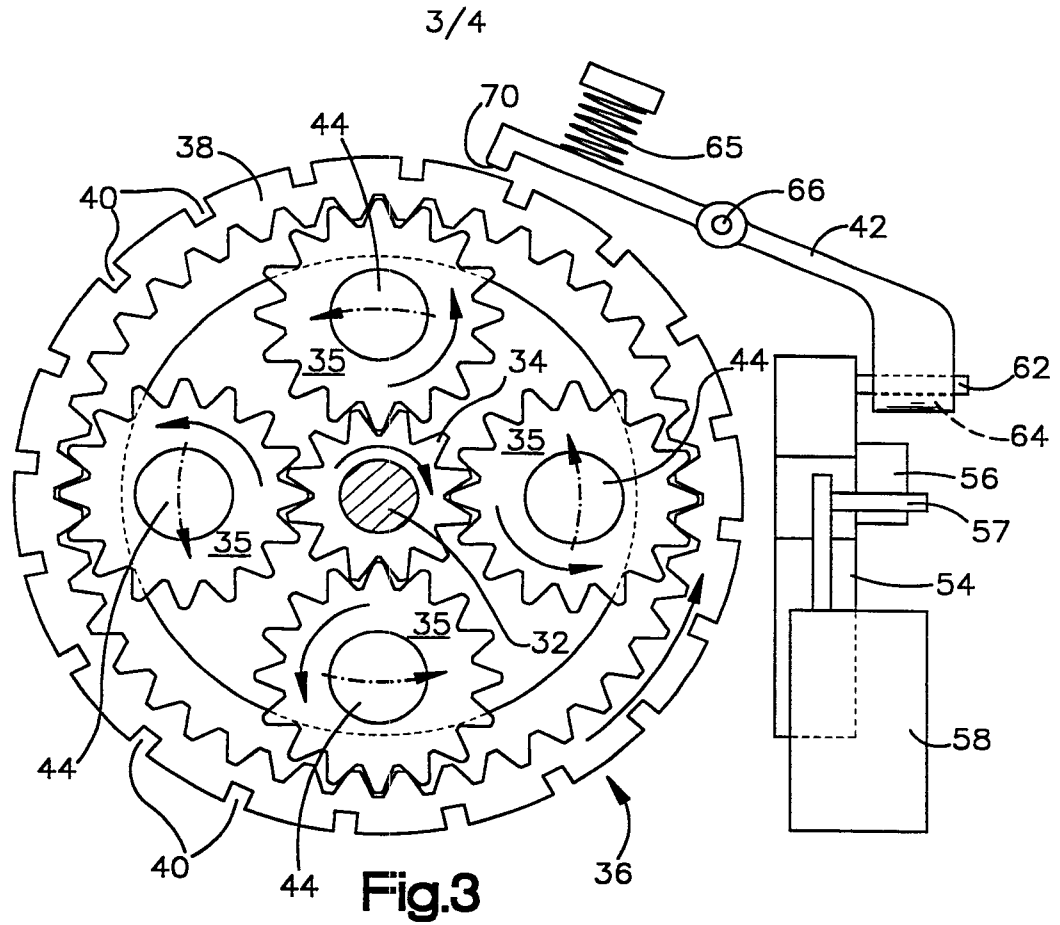

Fig.2



4/4

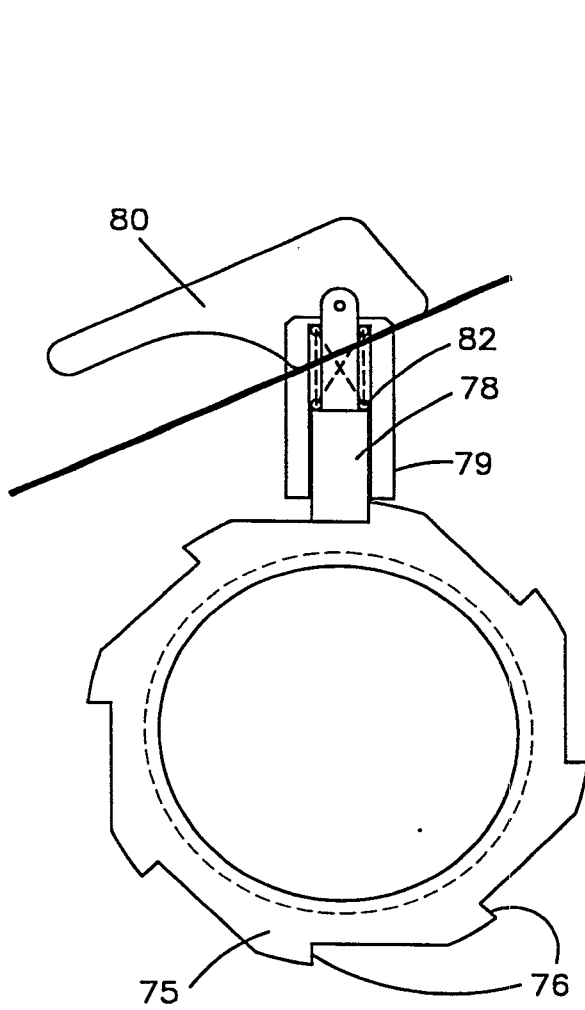

Fig.5

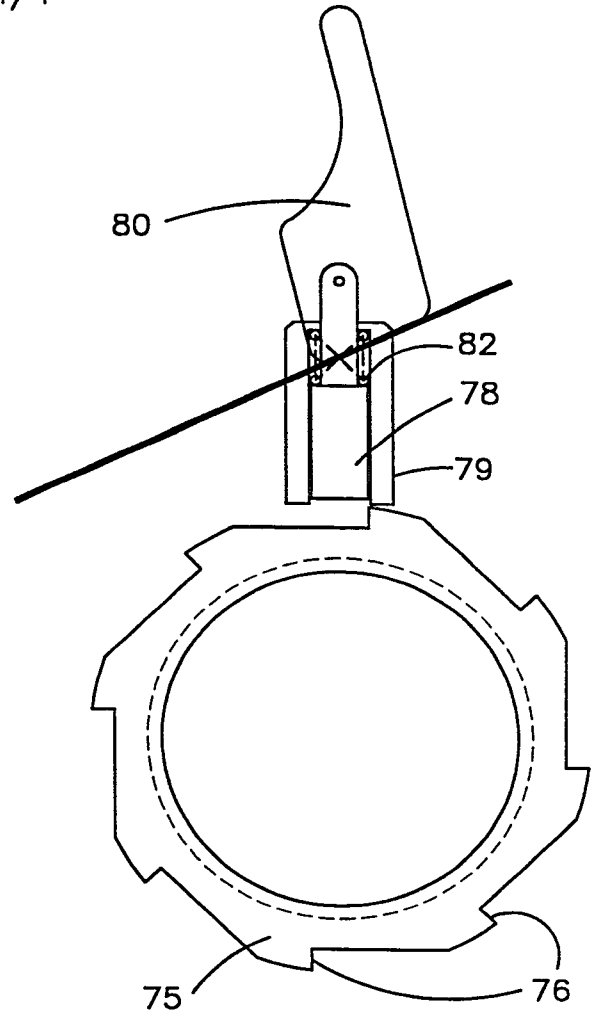

Fig.6

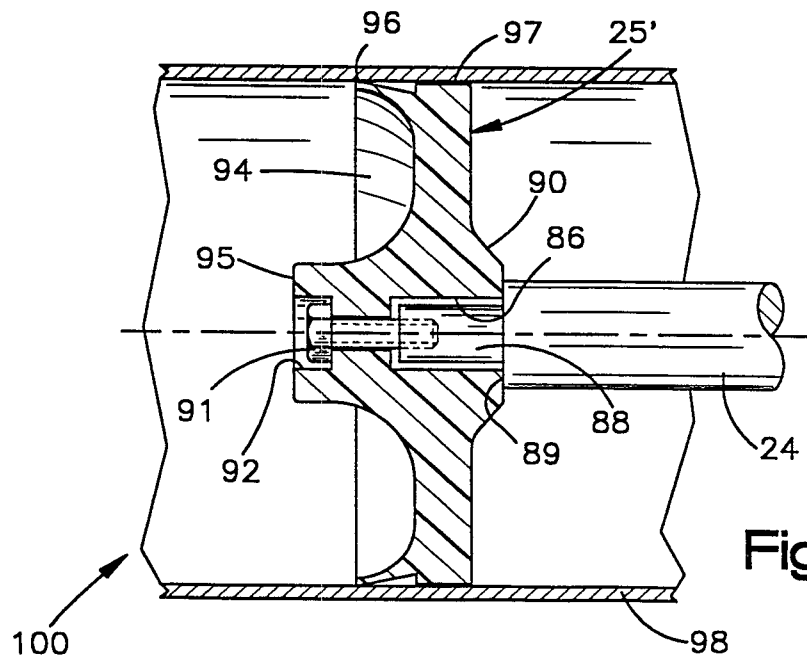

Fig.7

